

AVAYA DEFINITY ECS/ Prologix/GuestWorks C-LAN Connectivity (Release 1.0)

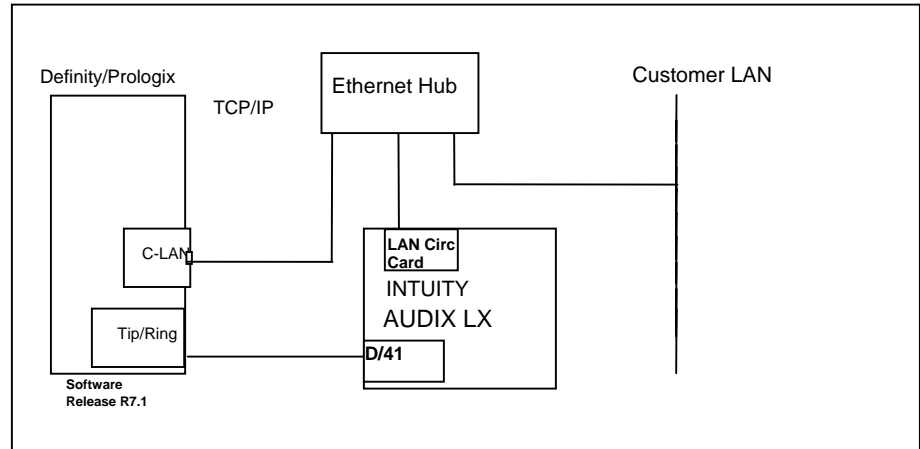

LANLink allows the DEFINITY ECS and the INTUITY AUDIX LX™ system to communicate over a private, dedicated LAN or a customer's LAN.

Avaya LANLink requirements

PBX hardware requirements

1.0 METHOD OF INTEGRATION

Connectivity to the INTUITY AUDIX LX™ through LANLink Software allows a telephone caller to integrate with a Host computer for information. LAN connectivity provides the ability to transfer messages through a local area network. The INTUITY AUDIX LX acts as the client computer and the DEFINITY as the server, and the TCP session will be initiated by the INTUITY AUDIX LX. There are three connectivity methods supported. Connecting can be achieved through a Direct connection, a Hub or Router connection, or through the customer's LAN.

2.0 AVAYA OVERLAN ORDERING INFORMATION

- LANSet SWIN package to replace the existing X.25 DCIU for INTUITY AUDIX LX to DEFINITY connectivity.
- INTUITY AUDIX LX Software Release 1.0.
- C-LAN Linux LANset Package.

3.0 PBX HARDWARE REQUIREMENTS

- C-LAN circuit pack (TN 799), 17 ports per card (port 17 is reserved for use with Ethernet)

3.1 PBX SOFTWARE REQUIREMENTS

Disclaimer: Configuration Notes are designed to be a general guide that reflects AVAYA Inc.'s experience configuring its systems. These notes cannot anticipate every configuration possibility given the inherent variations in all hardware and software products. Please understand that you could experience a problem not detailed in a Configuration Note. If so, please notify the TAC/TSO at (408) 922-1822, and if appropriate, we will include the problem in our next revision. AVAYA Inc. accepts no responsibility for errors or omissions contained herein.

- Minimum Software:
 - Host switch must have Release 7.1 or higher.
 - Remote switches can be DCS or DCS+ to older switches, allowed with TCP/IP to Release 7.1.

3.2 LAN CONNECTIVITY

- Ethernet LAN connectivity - TCP/IP
- Three Methods Supported:
 - Direct through crossover cable
 - Direct through a dedicated 10baseT hub
 - Through a router on a customer LAN

3.3 CUSTOMER-PROVIDED EQUIPMENT

- Wiring necessary to support the physical LAN (CAT 3 minimum)
- Ethernet Hub (location of 10baseT - optional)

3.4 DOCUMENTATION NEEDED

See the INTUITY AUDIX LX documentation CD-ROM:

- Getting Started
- Switch Integration

4.0 SUPPORTED FEATURES

- Calling Party ID
- Called Party ID
- Internal vs. External
- Direct vs. Redirected Call
- Busy/Ring-no-answer
- Message Waiting

5.0 OVERLAN QUALIFICATION

See the INTUITY AUDIX LX documentation CD-ROM for Switch integration requirements and LAN integration.

Planning Steps Before Installation

- ❑ Decide if the customer's environment meets the following requirements:

Complete the planning worksheets in the LAN/Switch Integration Planning before the installation. Completing the Planning worksheets ensures that the installer has all the needed information.

- ❑ Determine how the connection being made from the Avaya INTUITY AUDIX LX system to the DEFINITY switch. Choose from the following:
 - **Private LAN, no connectivity to customer LAN (uses private LAN addresses)**
 - Preferred option, most robust and reliable, no dependency on customer's network.
 - Crossover Cable is used for ease of connections.
 - Hub can be used instead of crossover cable extended distances. Up to four cables can be used.
 - **Customer LAN**
 - Preferred option when Avaya INTUITY AUDIX LX system Message Manager is needed.
 - Uses switch or router to provide a private collision domain.
 - Minimal dependency on customer's network.
 - Customer must provide equipment and administer network for private segment.
 - Customer's LAN administrator must be present during setup.
 - **Direct Connection**
 - Least preferred option.
 - Complete dependency on performance and reliability of customer's LAN.
 - Allows remote location of endpoints when customer LAN connectivity is convenient.
 - Customer's LAN administrator must be present during setup.
- ❑ If option the second or third option above is chosen, the following information is needed from the customer.
 - Gather customer network physical connectivity information:
 1. Location of 10BaseT network access point (hub, router, and so on)

2. Distance between C-LAN and network access point (328 ft. 100 m maximum)
3. Wiring access point, existing or new, Category 3 minimum required
 - Customer network administration information:
4. IP address of C-LANs, adjuncts, and gateways
5. Node names of C-LAN adjuncts and gateways
6. Subnet masks for all LAN segments containing C-LANs or adjuncts
7. Gateway IP address for all LAN segments that contain C-LANs, adjuncts, or routers
8. Will all endpoints (C-LANs and adjuncts) be on the same local LANsegment.
 - Network administration information needs to be mapped into specific administration fields.

Sanity check of information obtained from customer:

- If C-LAN and adjuncts are on the same LAN segment:
- Gateway IP address and subnet mask information is valid.
- All IP addresses contain the same subnet address.
- If C-LAN and adjuncts are on a different LAN segments, gateway IP addresses are different.

Without the above information, the Avaya technician will be unable to complete the installation. Installations that require the technicians to return because information was not available incur additional charges.

- Determine the location of the 10baseT network access point.
- Determine the distance between the C-LAN and the network access point.
- Determine if the customer will need LAN connectivity and support.

Note: The LAN cable, the connector at the end of the cable for connection to the Avaya INTUITY AUDIX LX system, and LAN administration not performed on the Avaya INTUITY AUDIX LX system are the responsibility of the customer, unless specified by contract.

- Working with the customer, determine the following:

- The number of ports, drives, and mailboxes required for the INTUITY AUDIX LX. Obtain IP address of C-LANs, adjuncts, and gateways.
- The node names
- Are all endpoints on the same local LAN

6.0 SWITCH CONFIGURATION FOR LAN INTEGRATION

For more information, click Help on the appropriate page or see the INTUITY AUDIX LX CD ROM for detailed information.

The following steps are required on the DEFINITY Switch to prepare for the C-LAN Integration. This is done on the “Host” switch:

- Define the Local Node number in the Dial Plan.
- Define the Avaya INTUITY AUDIX LX system voice ports as stations, including Class of Restriction (COR) and Class of Service (COS).
- Define a hunt group and add the Avaya INTUITY AUDIX LX system voice ports to that hunt group (configure local and remote hunt groups as required).
- If the switch is a csi model, assign the bus bridge. Ignore this step for G3SI and G3R applications, the packet bus is already active.
- On System-Parameters Maintenance screen, page 2, activate the Packet-Interface 2 and assign CLAN circuit Pack. Note that “01A07” is used as an example only. This example shows the bottom of the screen only, do not change any other existing entries on this page.

SPE OPTIONAL BORDS

Packet Intf1? y Packet Intf2? y
Bus Bridge: 01A07

-
- Assign Node names for the Avaya INTUITY AUDIX LX system and switch for G3 V7 or 8.
- If the ECS or Intuity is connected to a customer LAN/WAN the customer must supply the IP addresses to be used. In addition, they must also supply the IP addresses for remote locations.

NODE NAMES

Page 1 of 6

Configure the Link that will
connect to the INTUITY AUDIX LX
system

Audix Names	IP Address	MSA Names	IP Address
1. <u>intuity</u>	<u>192 . 168 . 2 . 3</u>	1.	<u>. . . .</u>

Page 2 of 6

NODE NAMES			
Names	IP Address	Names	IP Address
1. default	0 . 0 . 0 . 0	17	<u>. . . .</u>
2. ethernet	<u>192 . 168 . 2 . 2</u>	18	<u>. . . .</u>
3. <u> </u>	<u>. . . .</u>	19	<u>. . . .</u>
4. <u> </u>	<u>. . . .</u>	20	<u>. . . .</u>
5. <u> </u>	<u>. . . .</u>	21	<u>. . . .</u>
6. <u> </u>	<u>. . . .</u>	22	<u>. . . .</u>
7. <u> </u>	<u>. . . .</u>	23	<u>. . . .</u>
8. <u> </u>	<u>. . . .</u>	24	<u>. . . .</u>
9. <u> </u>	<u>. . . .</u>	25	<u>. . . .</u>
10. <u> </u>	<u>. . . .</u>	26	<u>. . . .</u>
11. <u> </u>	<u>. . . .</u>	27	<u>. . . .</u>
12. <u> </u>	<u>. . . .</u>	28	<u>. . . .</u>
13. <u> </u>	<u>. . . .</u>	29	<u>. . . .</u>
14. <u> </u>	<u>. . . .</u>	30	<u>. . . .</u>
15. <u> </u>	<u>. . . .</u>	31	<u>. . . .</u>
16. <u> </u>	<u>. . . .</u>	32	<u>. . . .</u>
<u>. . . .</u>	<u>. . . .</u>	<u>. . . .</u>	<u>. . . .</u>

- Add an Ethernet data module.

DATA MODULE	Page 1 of 1
--------------------	-------------

```

      Datayyyy          Name: Ethernet LAN Data Module
Extension: _____
      Type: ethernet
      Port: xxxxx17
      Link: 1
Enable Link? y

Node Name: ethernet
      Subnet Mask: 255 255 255 0
Broadcast Address: 192 168 2 255

      Automatic Subnet y
                  Routing? ___

```

- Use any valid extension number in the dial plan, a non-did number is preferred.
- NAME: Any valid name that defines the data module usage.
- Type will always be “ethernet”.
- Port number will always be xxxxx17, where xxxxx= the slot number of the CLAN circuit pack.
- Link can be 1-25 for G3SI and G3CSI and 1-33 for G3R. Link 1 is preferred.
- Enable Link? Must be set to “y” for link to be active, this can be set to “y” after the processor channel is assigned.
- Node Name: Must match the name assigned on the Node-Names screen.
- Subnet Mask: 255.255.255.0 for Class “C”, 255.255.0.0 for Class “B” and 255.0.0.0 for Class “A”.
- Broadcast Address: Use default for this Job Aid. If the IP Address is supplied by the customer, they must supply the Broadcast Address to be used.
- Automatic Subnet Routing: Always set to “y” for "direct connect" Intuity application.
- Administer a processor channel for the link from the switch to the Avaya INTUITY AUDIX LX system.

PROCESSOR CHANNEL ASSIGNMENT

Proc	Gtwy	Interfac e	Destinatio n	Session	Mac h
------	------	---------------	-----------------	---------	----------

Chan	Enabl	Appl.	To	Mode	Link / Chan	Node	Port	Loca / Remot	ID
1:	y	audix		s	1 5002	intuity	0	1 1	1

- Use any Processor Channel. Processor channel “1” is preferred. Processor Channel “59”, or any other channel may be used to match previous version of the ECS.

NOTE: When both CMS and INTUITY LX, use Processor Channel 10 for CMS.

- Enable: Always set to “y”, this channel will not go active until the link is enabled on the Ethernet Data Module.
- Appl: Set to “audix” for INTUITY LX, set to mis for CMS.
- Mode: Always set to “s” for Intuity application.
- Channel: Set to “5002”. For INTUITY LX or 5001 for CMS. If this is the only switch connected to the Intuity, if this is a shared Intuity submit an E-1154 to the SDSC.
- Destination Node: This name must match the name assigned to Intuity on the Node-Name screen.
- Destination Port: always “0” for direct connect Intuity LX and CMS.
- Session-Local: This field must match the Node Number assigned on the Dial Plan Screen for INTUITY and CMS, the session local is always “1”.
- Session-Remote: This field must match the AUDIX Number assigned in the Intuity and the Mach ID field on this Processor Channel screen. For INTUITY LX and CMS this field is always “1”.
- Mach ID: This field must match the AUDIX Number assigned in the Intuity and the Session-Remote field on this Processor Channel screen. For CMS, NO Mach ID is required.
- If this customer is using Router’s then you must configure the IP router table as follows:

IP ROUTE 1

IP ROUTING

Route Number: 1
Destination Node: gateway
Gateway: ethernet
C-LAN Board: XXXXX
Metric: 0

IP ROUTE 2

IP ROUTING

Route Number: 2
Destination Node: cms
Gateway: gateway
C-LAN Board: XXXXX
Metric: 0

- Set up a coverage path for access to the voice port hunt group for message retrieval.
- Apply the coverage path to stations, and if the switch is an r model, specify the node name of the Avaya INTUITY AUDIX LX system for each station that has a voice mailbox on the Avaya INTUITY AUDIX LX system.

If the customer is not using the Direct connection, the first step in administering the INTUITY AUDIX LX system for C-LAN integration is to place the INTUITY AUDIX LX onto the customers LAN.

6.1 INTUITY CONFIGURATION FOR LAN INTEGRATION

Refer to the INTUITY LX CDROM for details on the following steps required on the INTUITY Audix LX. The following define the steps required on the INTUITY AUDIX LX™.

- **HINT:** When changes to the Switch Interface Administration are completed, the system must then be restarted.
- Start at the Administration main menu and:
 - Select **Basic System Administration**.
 - Select **Switch Selection**.
 - From the pull-down menu for Country - Switch, Select United States - Definity Overlan
- Click **Save** and return to the Administration main menu.
 - Assign Channels to Groups.
 - Assign PBX Extensions to Channels.
 - Assign Services to Channels.
 - Assign Call Transfer.
- Start at the Administration main menu and:
 - Select **Switch Administration**
 - Select **Switch Link Administration**

Define Switch Link Type: **LAN**

Extension Length : **X** (X = number of digits in extension)

Host Switch Number : 1 (or which ever number is assigned for the Host)

Audix Number : 1 (or whichever number is assigned for the Audix)

Country: **United States**

Switch : **Definity Overlan**

Switch IP Address: **xxx.xxx.xxx**

TCP/IP Port: **5002**

Switch Number	IP Address Host Name	TCP Port
1	xxx.xxx.xxx	5002

Note: 5002 is the TCP port for the INTUITY AUDIX LX System use on a DEFINITY. 5002 must always be assigned to the host switch.

- From the Administration Main Menu.

- Select Basic System Administration.
- Select TCP/IP Administration.
- Select Network Addressing:
- Define the following:

Host Name: AUDIX

Default Gateway Address: See Note below

TCP/IP Interface: eth0 (this does not change for CLAN)

Primary Name + Domain: AUDIX.Avaya.com (case sensitive)

Enable DNS: recommend No, unless customer is using a name server

IP Address: xx.xx.xxx.xx (Intuity Audix IP address)

Subnet Mask: 255.255.255.0

Media Type: Auto_Detect

NOTE: Do not define a default gateway until the physical connection is made.

For remote switches that are not on the IP Network, the host switch provides translation and forwarding facilities on a separate TCP port. This port number and host switch IP address or host name is specified along with the remote switch number.

The Host name and Primary name **MUST** match and is case sensitive.

Click **Save**

- See the CD-ROM for further details on testing the installation
- To ensure the packet information is being passed from the Server perform a ping test in the INTUITY AUDIX LX.
 - From the **Administration main menu**:
 - Select **Diagnostics**.
 - Select **TCP/IP Diagnostics**.
 - Select “Send & Receive packets to and from (Ping Test).
 - To View Status select Name Server Loop Up Test, Link Diagnostics
- To view the status of the Link, check the following:
 - From the **Administration main menu**:
 - Select **Diagnostics**.

- Select **Switch Link Diagnostics**.
- Select *Link Diagnostics*.
- View Status of the Link

NOTE: If you encounter problems while performing these tasks, review the “switch log” before escalating problems to your local Technical Support Center.

- o After all the required programming is complete, stop and restart the INTUITY AUDIX LX.

6.2 CONNECTIVITY FOR DIRECT CONNECTION

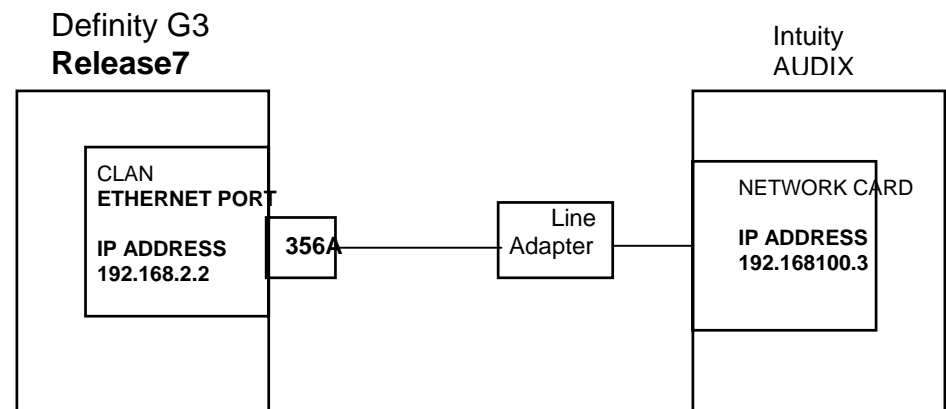

CONNECTIVITY WITH ROUTERS

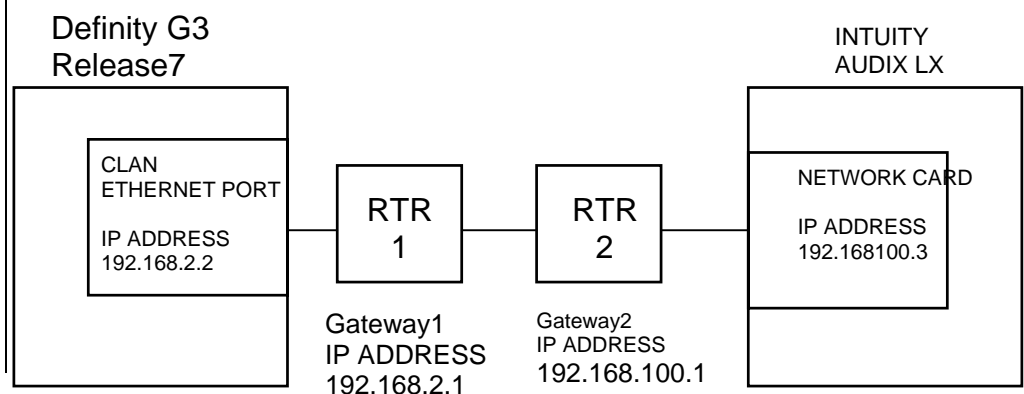

The following illustration shows a typical configuration of a connection to remote switches.

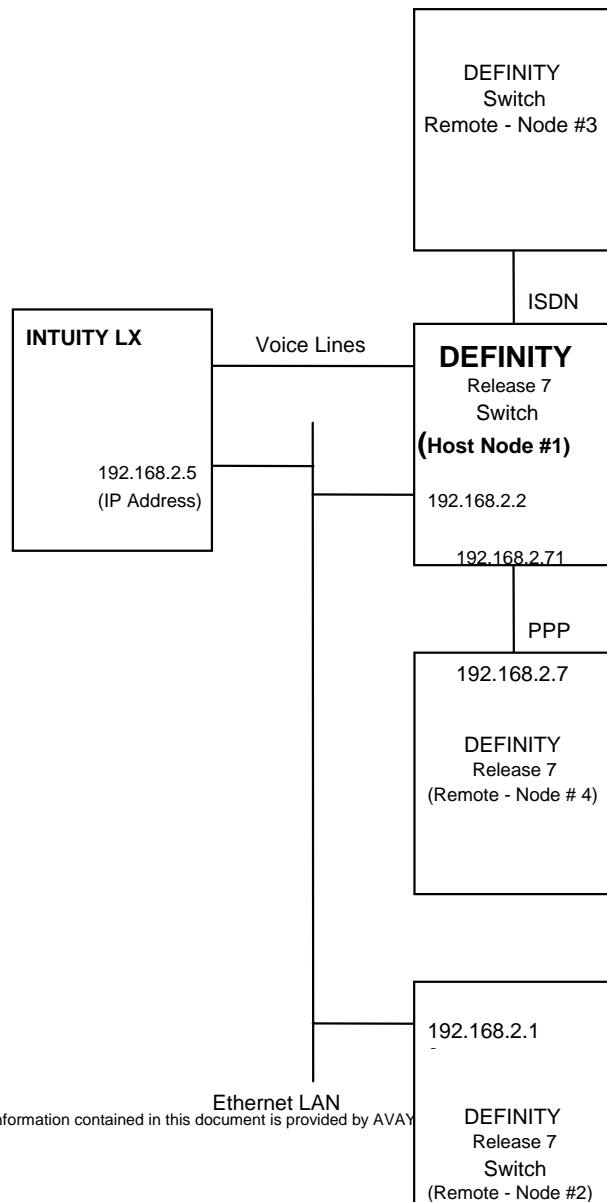

Installing the voice lines

7.0 INSTALLING THE VOICE LINES

Each voice card supports four analog (Tip/Ring) connections. The voice path between the DEFINITY and the INTUITY AUDIX LX™ requires one pair in each RJ11 connection of the voice card. See the installation instructions for the hardware connectivity.

- To ensure that the ports are physically connected correctly, ask the switch administrator to place calls to each individual INTUITY AUDIX LX™ voice channel, one at a time. Use the **System Monitor** menu in the INTUITY AUDIX LX™ to monitor that the correct channel is dialed from the switch.

Important notes

8.0 CONSIDERATIONS

8.1 C-LAN will not support synchronous PPP, and asynchronous PPP. Only 10baseT will be supported.

8.2 DCS is Avaya's networking package. In a DCS environment, subscribers on the remote nodes might not have the same integration feature functionality as those on the hub node.

8.3 AUDIX Networking is not supported through modems. Networking is supported by using TCP/IP only.

8.4 Digital Networking is not supported.

Revision	Issue Date	Reason for Change
Version A	10/02	Initial release

©2002 AVAYA Inc. All rights reserved. All trademarks identified by the ®, SM and TM are registered trademarks, servicemarks or trademarks respectively. All other trademarks are properties of their respective owners. The above information is based on knowledge available at the time of publication and is subject to change without notice. Printed in U.S.A.

AVAYA Inc.

1001 Murphy Ranch Road

Milpitas, CA 95035-7912

(408) 321-2000

<http://www.avaya.com>**PN 001-7-9514**