



Intel® Dialogic® D/82JCTU

Quick Install Card for PCI

- Configuration
- Installation
- Connections
- RMA Process

Part Number 05-2045-001
Copyright © 2003 Intel Corporation

Read Me First

Protect Yourself from Electric Shock

To reduce the risk of electric shock:

- Switch off the power and remove power cords before opening the PC cover to install the D/82JCT-U.
- Do not re-attach power cords and switch on power to the PC while the PC cover is removed.

Protect the Board from Static Electricity

Computer boards are static-sensitive and can be damaged by touching or handling them. To prevent damage from static electricity, do the following:

- Wear a grounded, static-dissipative wrist-strap for the entire hardware installation.
- Keep the board in its anti-static container when it is not being handled.
- Work at a static-safe work area (see Figure 1).

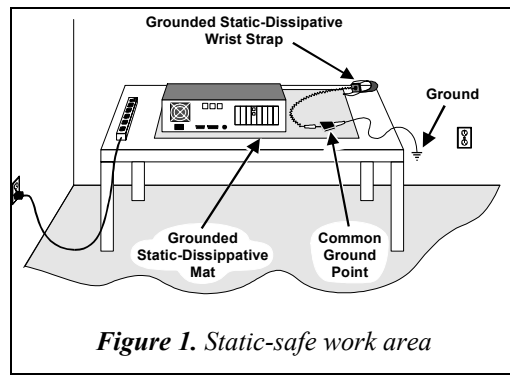

Figure 1. Static-safe work area

Read Your Software Documentation

Your application software or system software (hereinafter collectively called “voice software”) may have special installation or configuration instructions or requirements. Be sure to read all software documentation for any such instructions or requirements.

Configure the D/82JCT-U

The D/82JCT-U board is a PCI form factor board that uses hardware auto-configuration for IRQ and memory address. It allows you to use the factory default hardware settings for quick installation and operation. However, Intel Corporation recommends that you review the following information and select options as desired.

Board Numbering

When you start Intel® Dialogic® boards, each board is assigned a Board ID number for identification and use by the application program.

All Intel® Dialogic® PCI boards with a rotary switch can share the factory default switch setting and Board ID of 0. To give a PCI board with a rotary switch a Board ID other than 0, the rotary switch is set to the desired number. Because the D/82JCT-U board has no rotary switch, the Intel Dialogic Configuration Manager (DCM) software that is provided with the board automatically assigns Board IDs, beginning with 0, unless there are other PCI boards with a rotary switch settings of 0, 1, 2, etc. In that case, DCM would assign the first available Board ID not in use.

Unlike boards with rotary switches, the Board ID cannot be changed from the automatic setting on the D/82JCT-U hardware: it must be changed using DCM. See DCM help files for more information about changing Board IDs.

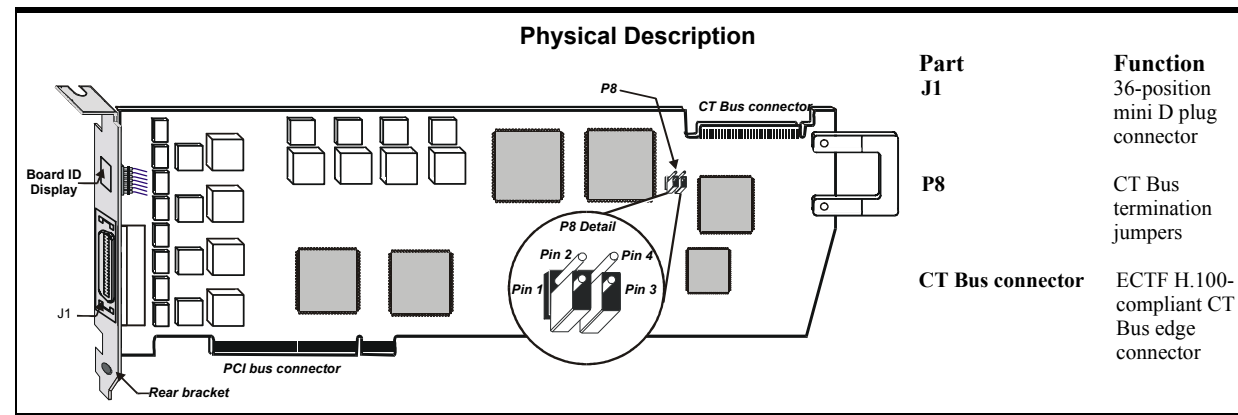

Note: If you add PCI boards with rotary switches to your system after D/82JCT-U boards have been assigned, boards may share the same ID, depending on the rotary switch settings of the new boards. For instance, if DCM has assigned Board IDs 01, 02, and 03 to existing D/82JCT-U boards, and then the rotary switches on three new boards are set to 1, 2, and 3, the D/82JCT-U and new boards will share Board IDs 01, 02, and 03.

The D/82JCT-U Board ID appears on the 2-character LED display on the rear bracket of the board, along with error codes, when appropriate.

Display	Meaning
00-xx	Board ID (in hexadecimal numbers)
88	PCI Bus reset active
D0	Front-end download or initialization failed
E1-E8	Error on PBX port 0-7 (channel 1-8)

Following download, the Board ID is displayed on the LED until a communications error is experienced on one or more of the PBX ports. When errors are present, they are displayed for two seconds, alternating with the Board ID for two seconds.

P8 CT Bus Termination

Jumpers are used to terminate signals on the CT Bus. These settings apply to boards located at physical ends of the bus. For SCbus, both CT_C8_(A&B) and CT_FRAME_(A&B) are terminated using pins 1 and 2 of the P8 termination jumpers. For MVIP, C-2 and C-4* are terminated using pins 3 and 4 of the P8 termination jumpers.

Shunt	Terminates	Standard
P8, Pins 1 and 2	CT_FRAME_(A&B) CT_C8_(A&B)	SCbus
P8, Pins 3 and 4	C-2 and C-4*	MVIP

NOTE: Only the boards at the ends of the ribbon cable must have their terminations enabled. All other boards must not have the jumper clips installed.

Install the D/82JCT-U

Install each board in the PC chassis using adjacent PCI slots according to the following instructions.

1. Turn off all power to the system, and disconnect the system's power cords from electrical outlets.
2. Remove the PC cover.
3. Select an empty PCI expansion bus slot, and remove the slot's retaining screw and access coverplate.

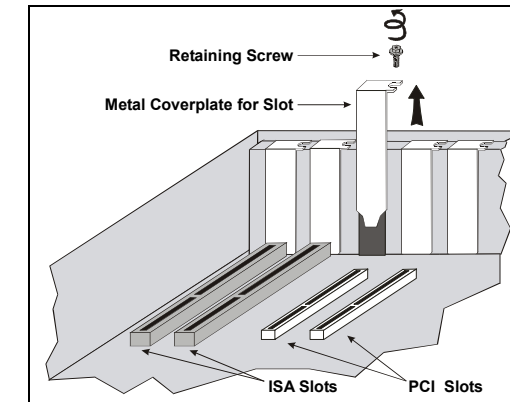

Figure 2. View of internal PC expansion slots

Note: If the PC is designed for PCI boards only, remove the slot retainer bracket from the end of the board before installing the board. The slot retainer bracket allows you to install the board in a PC chassis that contains both ISA and PCI slots (where the PCI slots use the ISA form-factor).

4. Insert the board's edge connector into the bus slot. Apply pressure only to the top edge of the board, and gently rock the board forward and backward to seat the edge connector into the slot.

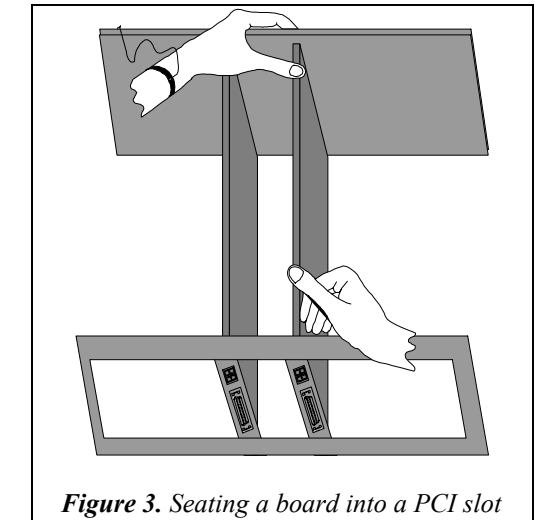

Figure 3. Seating a board into a PCI slot

5. Install the retaining screw.

Note: If the screw is not installed and you attach a CT Bus cable, it can unseat the board from the slot.

Connect CT Bus Ribbon Cable

The CT Bus cable (not included) connects Intel® Dialogic® boards to the H.100-compliant Computer Telephony bus (CT Bus).

Note: Full H.100 capabilities are not available with this release of the D/82JCT-U.

Follow the instructions in this section depending upon whether the board will be connected to the CT Bus or used in “stand-alone” mode (without the CT Bus).

- **Stand-Alone Mode (CT Bus Cable Not Needed):** Skip the instructions in this section if the Intel®

Dialogic® boards are used in “stand-alone” mode (where the application does not use time-slot routing).

- **CT Bus Mode (CT Bus Cable Needed):** Attach the CT Bus cable to the Intel® Dialogic® boards as described in the following instructions if the boards use the CT Bus (the application program controls resources on the boards through time-slot routing).

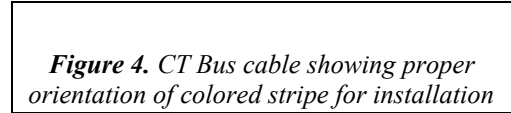

1. Attach the end connector on the ribbon cable to the CT Bus edge connector on the top edge of the first board. The connectors are designed to fit together one way only. If the connector does not seat fully on the board, turn the cable around and try again. Make sure that the colored stripe on the cable faces toward the rear bracket. (The stripe should be adjacent to pin 1 on the board connector.)

2. Attach the ribbon cable to the next board until all boards are connected by the cable.

Note: To connect the CT Bus to an SCbus, attach an Intel® Tekcom Products CT Bus/SCbus Adapter (not included) to one of the boards and connect the SCbus cable to this adapter. See the hardware installation instructions for the CT Bus/SCbus Adapter for more information.

3. If the ribbon cable has extra connectors or loose cable, tuck the cable down so that it does not snag when you replace the PC cover.

4. After installing and connecting all the boards, replace the PC cover, cables, and cords.

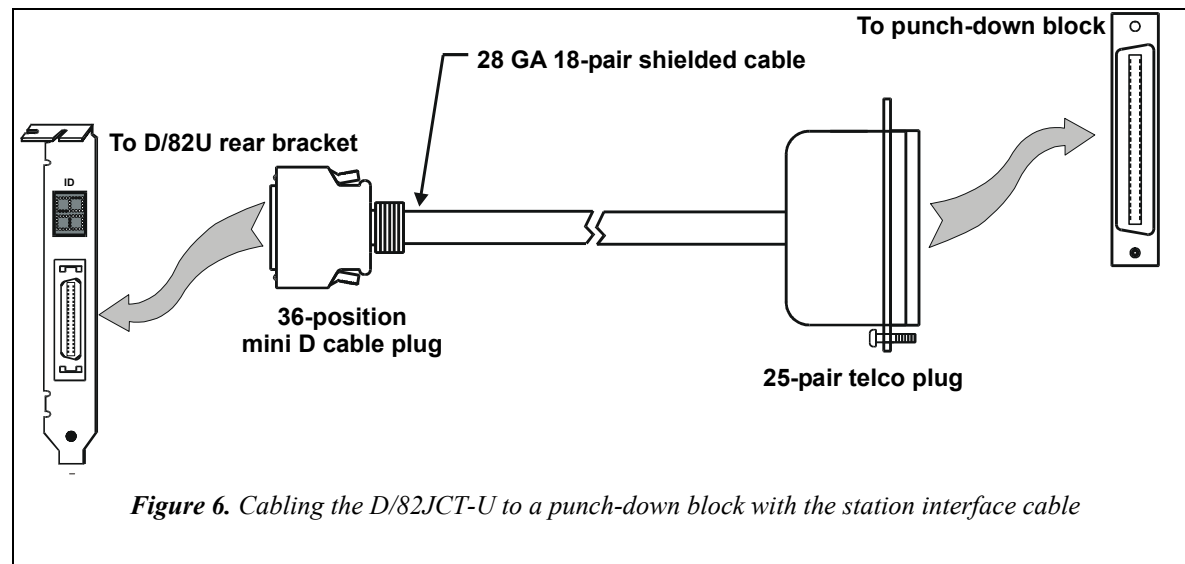

Figure 6. Cabling the D/82JCT-U to a punch-down block with the station interface cable

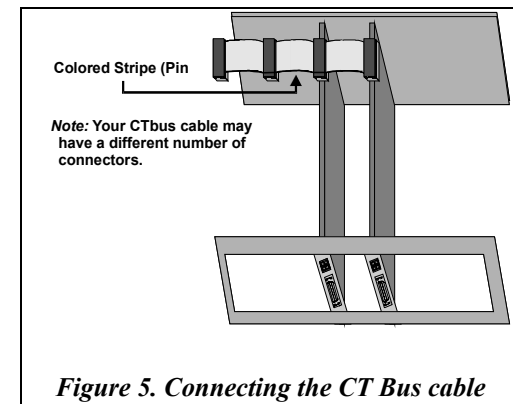

Figure 5. Connecting the CT Bus cable

arranged so that the four conductors of one station set circuit are adjacent on a standard, type-66 punch-down block. The pattern shown in Figure 8 continues down the connector so as to encompass all eight channels with two pairs of conductors per channel, for a total of 16 twisted-pair conductors.

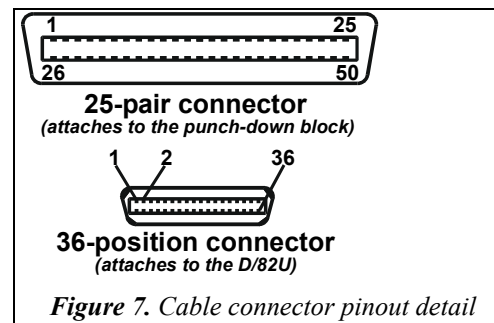

Figure 7. Cable connector pinout detail

Connect External Cable

- A D/82JCT-U-specific, PBX station interface cable (available as a separate sales item, part # 06-0155-001) is used to connect the D/82JCT-U board to a punch-down block (see Figure 6).
- As shown in Figure 7, the station interface cable terminates at the punch-down block end with a 25-pair, 57-series Amphenol plug to allow available type-66 punch-down blocks to be used to terminate the PBX station wiring. The mini-D cable that connects to the D/82JCT-U has a 36-position connector.
- The Telco plug cable connector tabulation is

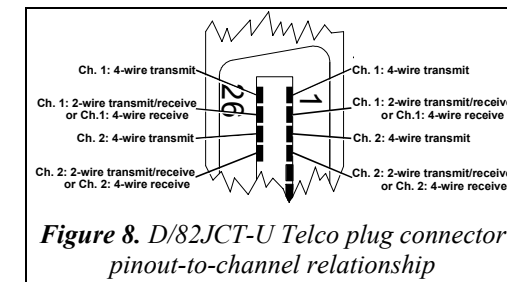

Figure 8. D/82JCT-U Telco plug connector pinout-to-channel relationship

After D/82JCT-U Installation

- Run the firmware download utility that came with your voice software to download the firmware to the D/82JCT-U.
- Test the D/82JCT-U with a demonstration program such as the Multi-threaded Voice demo.
- For specifications, product information, or technical support, refer to the Intel Telecom Products web site at: <http://www.intel.com/design/network/products/telecom/index.htm>

RMA Process

Repair of Merchandise Authorization (RMA) Process

To return a board for repair or credit in the American geographies, use the online form at <http://www.intel.com/support/motherboards/draform.htm>

To return a board for repair or credit in all other geographies, please contact your distributor.

Windows and Windows NT are registered trademarks of Microsoft Corporation.

To connect your D/82JCT-U board to a punch-down block, follow the instructions below:

1. Connect your station interface cable’s 36-position mini D cable plug to the connector on the rear bracket of the D/82JCT-U.
2. Connect your station interface cable’s 25-pin telco plug to the connector on the punch-down block.

Hardware installation is now complete.