



# **Administering Avaya Aura<sup>®</sup> Call Center Elite Multichannel**

Release 6.3.x  
August 2014

## Notice

While reasonable efforts have been made to ensure that the information in this document is complete and accurate at the time of printing, Avaya assumes no liability for any errors. Avaya reserves the right to make changes and corrections to the information in this document without the obligation to notify any person or organization of such changes.

## Documentation disclaimer

"Documentation" means information published by Avaya in varying mediums which may include product information, operating instructions and performance specifications that Avaya may generally make available to users of its products and Hosted Services. Documentation does not include marketing materials. Avaya shall not be responsible for any modifications, additions, or deletions to the original published version of documentation unless such modifications, additions, or deletions were performed by Avaya. End User agrees to indemnify and hold harmless Avaya, Avaya's agents, servants and employees against all claims, lawsuits, demands and judgments arising out of, or in connection with, subsequent modifications, additions or deletions to this documentation, to the extent made by End User.

## Link disclaimer

Avaya is not responsible for the contents or reliability of any linked websites referenced within this site or documentation provided by Avaya. Avaya is not responsible for the accuracy of any information, statement or content provided on these sites and does not necessarily endorse the products, services, or information described or offered within them. Avaya does not guarantee that these links will work all the time and has no control over the availability of the linked pages.

## Warranty

Avaya provides a limited warranty on Avaya hardware and software. Refer to your sales agreement to establish the terms of the limited warranty. In addition, Avaya's standard warranty language, as well as information regarding support for this product while under warranty is available to Avaya customers and other parties through the Avaya Support website: <http://support.avaya.com> or such successor site as designated by Avaya. Please note that if you acquired the product(s) from an authorized Avaya Channel Partner outside of the United States and Canada, the warranty is provided to you by said Avaya Channel Partner and not by Avaya.

## Licenses

THE SOFTWARE LICENSE TERMS AVAILABLE ON THE AVAYA WEBSITE, [HTTP://SUPPORT.AVAYA.COM/LICENSEINFO](http://support.avaya.com/licenseinfo) OR SUCH SUCCESSOR SITE AS DESIGNATED BY AVAYA, ARE APPLICABLE TO ANYONE WHO DOWNLOADS, USES AND/OR INSTALLS AVAYA SOFTWARE, PURCHASED FROM AVAYA INC., ANY AVAYA AFFILIATE, OR AN AVAYA CHANNEL PARTNER (AS APPLICABLE) UNDER A COMMERCIAL AGREEMENT WITH AVAYA OR AN AVAYA CHANNEL PARTNER. UNLESS OTHERWISE AGREED TO BY AVAYA IN WRITING, AVAYA DOES NOT EXTEND THIS LICENSE IF THE SOFTWARE WAS OBTAINED FROM ANYONE OTHER THAN AVAYA, AN AVAYA AFFILIATE OR AN AVAYA CHANNEL PARTNER; AVAYA RESERVES THE RIGHT TO TAKE LEGAL ACTION AGAINST YOU AND ANYONE ELSE USING OR SELLING THE SOFTWARE WITHOUT A LICENSE. BY INSTALLING, DOWNLOADING OR USING THE SOFTWARE, OR AUTHORIZING OTHERS TO DO SO, YOU, ON BEHALF OF YOURSELF AND THE ENTITY FOR WHOM YOU ARE INSTALLING, DOWNLOADING OR USING THE SOFTWARE (HEREINAFTER REFERRED TO INTERCHANGEABLY AS "YOU" AND "END USER"), AGREE TO THESE TERMS AND CONDITIONS AND CREATE A BINDING CONTRACT BETWEEN YOU AND AVAYA INC. OR THE APPLICABLE AVAYA AFFILIATE ("AVAYA").

Avaya grants you a license within the scope of the license types described below, with the exception of Heritage Nortel Software, for which the scope of the license is detailed below. Where the order documentation does not expressly identify a license type, the applicable license will be a Designated System License. The

applicable number of licenses and units of capacity for which the license is granted will be one (1), unless a different number of licenses or units of capacity is specified in the documentation or other materials available to you. "Software" means Avaya's computer programs in object code, provided by Avaya or an Avaya Channel Partner, whether as stand-alone products, pre-installed, or remotely accessed on hardware products, and any upgrades, updates, bug fixes, or modified versions thereto. "Designated Processor" means a single stand-alone computing device. "Server" means a Designated Processor that hosts a software application to be accessed by multiple users. "Instance" means a single copy of the Software executing at a particular time: (i) on one physical machine; or (ii) on one deployed software virtual machine ("VM") or similar deployment.

## License types

**Designated System(s) License (DS).** End User may install and use each copy or an Instance of the Software only on a number of Designated Processors up to the number indicated in the order. Avaya may require the Designated Processor(s) to be identified in the order by type, serial number, feature key, Instance, location or other specific designation, or to be provided by End User to Avaya through electronic means established by Avaya specifically for this purpose.

**Concurrent User License (CU).** End User may install and use the Software on multiple Designated Processors or one or more Servers, so long as only the licensed number of Units are accessing and using the Software at any given time. A "Unit" means the unit on which Avaya, at its sole discretion, bases the pricing of its licenses and can be, without limitation, an agent, port or user, an e-mail or voice mail account in the name of a person or corporate function (e.g., webmaster or helpdesk), or a directory entry in the administrative database utilized by the Software that permits one user to interface with the Software. Units may be linked to a specific, identified Server or an Instance of the Software.

## Copyright

Except where expressly stated otherwise, no use should be made of materials on this site, the Documentation, Software, Hosted Service, or hardware provided by Avaya. All content on this site, the documentation, Hosted Service, and the Product provided by Avaya including the selection, arrangement and design of the content is owned either by Avaya or its licensors and is protected by copyright and other intellectual property laws including the sui generis rights relating to the protection of databases. You may not modify, copy, reproduce, republish, upload, post, transmit or distribute in any way any content, in whole or in part, including any code and software unless expressly authorized by Avaya. Unauthorized reproduction, transmission, dissemination, storage, and or use without the express written consent of Avaya can be a criminal, as well as a civil offense under the applicable law.

## Third Party Components

"Third Party Components" mean certain software programs or portions thereof included in the Software or Hosted Service may contain software (including open source software) distributed under third party agreements ("Third Party Components"), which contain terms regarding the rights to use certain portions of the Software ("Third Party Terms"). As required, information regarding distributed Linux OS source code (for those Products that have distributed Linux OS source code) and identifying the copyright holders of the Third Party Components and the Third Party Terms that apply is available in the Documentation or on Avaya's website at: <http://support.avaya.com/Copyright> or such successor site as designated by Avaya. You agree to the Third Party Terms for any such Third Party Components.

## Note to Service Provider

The Product or Hosted Service may use Third Party Components subject to Third Party Terms that do not allow hosting and require a Service Provider to be independently licensed for such purpose. It is your responsibility to obtain such licensing.

## Preventing Toll Fraud

"Toll Fraud" is the unauthorized use of your telecommunications system by an unauthorized party (for example, a person who is not a corporate employee, agent, subcontractor, or is not working on your company's behalf). Be aware that there can be a risk of Toll Fraud associated with your system and that, if Toll Fraud occurs, it can

result in substantial additional charges for your telecommunications services.

#### **Avaya Toll Fraud intervention**

If you suspect that you are being victimized by Toll Fraud and you need technical assistance or support, call Technical Service Center Toll Fraud Intervention Hotline at +1-800-643-2353 for the United States and Canada. For additional support telephone numbers, see the Avaya Support website: <http://support.avaya.com> or such successor site as designated by Avaya. Suspected security vulnerabilities with Avaya products should be reported to Avaya by sending mail to: [securityalerts@avaya.com](mailto:securityalerts@avaya.com).

#### **Trademarks**

The trademarks, logos and service marks ("Marks") displayed in this site, the Documentation, Hosted Service(s), and Product(s) provided by Avaya are the registered or unregistered Marks of Avaya, its affiliates, or other third parties. Users are not permitted to use such Marks without prior written consent from Avaya or such third party which may own the Mark. Nothing contained in this site, the Documentation, Hosted Service(s) and Product(s) should be construed as granting, by implication, estoppel, or otherwise, any license or right in and to the Marks without the express written permission of Avaya or the applicable third party.

Avaya is a registered trademark of Avaya Inc.

All non-Avaya trademarks are the property of their respective owners. Linux<sup>®</sup> is the registered trademark of Linus Torvalds in the U.S. and other countries.

#### **Downloading Documentation**

For the most current versions of Documentation, see the Avaya Support website: <http://support.avaya.com>, or such successor site as designated by Avaya.

#### **Contact Avaya Support**

See the Avaya Support website: <http://support.avaya.com> for Product or Hosted Service notices and articles, or to report a problem with your Avaya Product or Hosted Service. For a list of support telephone numbers and contact addresses, go to the Avaya Support website: <http://support.avaya.com> (or such successor site as designated by Avaya), scroll to the bottom of the page, and select Contact Avaya Support.

# Contents

<b>Chapter 1: Introduction</b> .....	16
Purpose.....	16
Intended audience.....	16
Reasons for reissue.....	16
What is new in this document?.....	16
Related resources.....	17
Documentation.....	17
Training.....	19
Viewing Avaya Mentor videos.....	19
Support.....	20
<b>Chapter 2: Overview</b> .....	21
Components of Application Management Service.....	21
<b>Chapter 3: Configuring the Call Center Elite Multichannel databases</b> .....	23
Creating databases.....	23
Creating a new ASMSDataX database.....	24
Removing an old ASMSDataX database.....	25
Viewing database management options.....	25
Call Center Elite Multichannel databases recommendation for high traffic systems.....	26
Configuring the tmp database.....	27
Configuring file groups.....	27
Turning off Auto Shrink.....	28
Setting the secondary file group as default.....	29
<b>Chapter 4: Services configuration</b> .....	30
Start, configure, and monitor services.....	30
Starting a Call Center Elite Multichannel service.....	30
Starting Call Center Elite Multichannel Control Panel.....	31
Communication Manager administration.....	32
Security Warning Banner.....	32
Configuring security warning banner.....	32
Call Recording.....	32
Configuring Call Recording Controller.....	33
License Director.....	34
Types of license keys.....	34
License Director overview.....	35
Licensing error messages.....	36
Distribution of license servers.....	37
Checklist for implementing and administering License Director.....	37
Viewing license keys.....	37
WebLM Server overview.....	38

Adding licenses to WebLM Server.....	38
XML Server.....	39
XML Service.....	39
XML Client.....	39
Licensing for XML Server.....	41
XML Server error messages.....	41
XML Server configuration overview.....	41
Checklist for implementing and administering XML Server.....	42
Adding a Telephony Server to XML Server.....	43
Media Director.....	44
Work items.....	45
Avaya Communication Manager algorithms.....	45
Licensing for Media Director.....	46
Checklist for configuring Media Director.....	46
Switch settings sample.....	46
Setting up Telephony Server.....	49
Virtual Agent.....	50
Worker plug-ins.....	50
Configuring Virtual Agent.....	54
Configuring XML Server for Virtual Agent.....	55
Configuring a Virtual Agent group.....	57
Adding a Virtual Agent group.....	57
Configuring Virtual Agent Workers.....	59
Configuring Virtual Agent for Web service.....	59
Customized programs for Outbound work items.....	60
Integrating Experience Portal with Virtual Agent Web Service.....	62
Web Service Worker plug-in architecture.....	62
Web Service methods.....	64
Media Gateways.....	70
The Multimedia environment.....	71
Messenger Gateways configuration overview.....	71
Media Stores.....	73
Media Stores overview.....	73
Checklist for implementing and administering Media Stores.....	74
Email Media Store.....	75
Preview Contact Media Store.....	83
Voice Media Store.....	85
Simple Messaging Media Store.....	96
Backup / Restore / Delete databases.....	97
Media Store databases migration.....	97
Assigning a canned message group to a program.....	98
Experience Portal Management Server.....	98
TTrace config tool to send automatic email on configurable alarms.....	99

<b>Chapter 5: Configuring Call Center Elite Multichannel core services</b> .....	100
Prerequisites for configuring Call Center Elite Multichannel core services.....	100
Configuring License Director.....	100
Edit License Director field descriptions.....	101
Configuring Application Management Service.....	102
Configuring an XML server.....	102
Edit XML Server field descriptions.....	102
Configuring Media Director.....	103
Edit Media Director field descriptions.....	104
<b>Chapter 6: Configuring Voice channel</b> .....	105
Prerequisites for configuring Voice channel.....	105
Checklist for configuring Voice channel.....	105
Creating a schedule.....	105
Add Schedule field descriptions.....	106
Creating an AutoText group/Work Code.....	107
Adding AutoText entries in an AutoText group.....	107
Supported variables in the AutoText Plug-in.....	108
Creating a program.....	110
Add Program field descriptions.....	111
Assigning a schedule to a program.....	114
Assign Schedule field descriptions.....	114
Configuring Voice Media Store.....	115
Edit Voice Media Store field descriptions.....	115
Configuring XML Server for Voice Media Store.....	117
Edit XML Server for VMS field descriptions.....	117
Adding XML Server for Voice Media Store.....	121
<b>Chapter 7: Configuring Email channel</b> .....	122
Prerequisites for configuring Email channel.....	122
Checklist for configuring Email channel.....	122
Creating a schedule.....	122
Add Schedule field descriptions.....	123
Creating an AutoText group/Work Code.....	124
Adding AutoText entries in an AutoText group.....	124
Supported variables in the AutoText Plug-in.....	125
Creating a program.....	127
Add Program field descriptions.....	128
Assigning a schedule to a program.....	131
Assign Schedule field descriptions.....	131
Adding a queue to Media Director.....	132
Add Queue field descriptions.....	132
Configuring Email Media Store.....	134
Edit Email Media Store field descriptions.....	135
Adding a queue for Email Media Store.....	136

General field descriptions.....	137
Inbound field descriptions.....	139
Outbound field descriptions.....	141
Auto Response field descriptions.....	142
Components field descriptions.....	146
<b>Chapter 8: Configuring Simple Messaging Media Store channel.....</b>	<b>148</b>
Prerequisites for configuring Simple Messaging Media Store channel.....	148
Checklist for configuring Simple Messaging Media Store channel.....	148
Creating a schedule.....	149
Add Schedule field descriptions.....	149
Creating an AutoText group/Work Code.....	150
Adding AutoText entries in an AutoText group.....	150
Supported variables in the AutoText Plug-in.....	151
Creating a program.....	153
Add Program field descriptions.....	154
Assigning a schedule to a program.....	157
Assign Schedule field descriptions.....	158
Adding a queue to Media Director.....	158
Add Queue field descriptions.....	159
Configuring Simple Messaging Media Store.....	160
Edit SMMS Details field descriptions.....	161
Adding a queue for Simple Messaging Media Store.....	162
Add Queue for Simple Messaging Media Store field descriptions.....	162
Viewing an existing queue.....	164
Closing a queue.....	165
Reopening a queue.....	165
Opening or closing a queue based on schedule.....	165
Web Chat Gateway.....	166
Configuring the Web Chat Gateway.....	166
Adding a Web Chat remote service.....	167
Customizing Web Chat ASP.....	169
Customizing Web Chat Web Service.....	171
Supported browsers for Web Chat ASP.....	174
AOL-ICQ Instant Messenger Gateway.....	175
Configuring an AOL-ICQ Instant Messenger Gateway.....	175
Adding an AOL-ICQ Instant Messenger remote service.....	175
MSN Messenger Gateway.....	178
Configuring an MSN Messenger Gateway.....	178
Adding an MSN Instant Messenger remote service.....	179
Short Message Service Gateway.....	181
Configuring Short Message Service Gateway.....	181
Adding a Short Message Service remote service.....	182
Communicator Gateway.....	185

Configuring a Communicator Gateway.....	185
Adding an Office Communicator remote service.....	186
XMPP/GTalk Gateway.....	192
Configuring an XMPP or a GTalk Gateway.....	192
Adding an XMPP or a GTalk remote service.....	193
Chat canned messages.....	195
<b>Chapter 9: Configuring Outbound channel.....</b>	<b>199</b>
Prerequisites for configuring Outbound channel.....	199
Checklist for configuring Outbound channel.....	199
Creating a schedule.....	199
Add Schedule field descriptions.....	200
Creating an AutoText group/Work Code.....	201
Adding AutoText entries in an AutoText group.....	201
Supported variables in the AutoText Plug-in.....	202
Creating a program.....	204
Add Program field descriptions.....	205
Assigning a schedule to a program.....	208
Assign Schedule field descriptions.....	208
Adding a queue to Media Director.....	209
Add Queue field descriptions.....	209
Configuring Preview Contact Media Store.....	211
Edit Preview Contact Media Store field descriptions.....	212
<b>Chapter 10: Media Store database.....</b>	<b>213</b>
Deploying report files.....	213
Outbound programs for virtual agents.....	215
Creating an outbound program for Preview Contact Media Store.....	215
Creating an outbound program for email or simple messaging Media Store.....	217
Customizing multimedia work items by adding work forms.....	217
Reordering the forms controls.....	218
<b>Chapter 11: Contact database.....</b>	<b>219</b>
Contact overview.....	219
Contact Gateway.....	220
Groups.....	220
Search capability.....	221
PhoneLookUp.....	222
ASContact Contacts table.....	222
Media Store permissions.....	223
Permission options.....	223
AssociatedData.....	225
Rating.....	226
Overall rating.....	226
Database configuration.....	226
Identification and searches.....	227



Gateway view modification.....	227
Creating a link to an external server.....	227
Modifying the gateway view.....	228
ASContact database customization.....	228
The gateway view.....	228
ASContact database data handling.....	229
PhoneLookUp table maintenance.....	232
External database.....	232
ASContact Database configuration.....	233
Contact groups.....	234
Column display.....	236
Permissions of a contact or a group of contacts.....	238
<b>Chapter 12: Communication Manager administration.....</b>	<b>243</b>
Configuring Communication Manager connection.....	243
Edit Connection Configuration field descriptions.....	243
Communication Manager interface.....	244
Agents field descriptions.....	245
Stations field descriptions.....	248
Skills field descriptions.....	249
VDNs field descriptions.....	256
Holiday Tables field descriptions.....	259
Service Hours Tables field descriptions.....	260
Software version field descriptions.....	261
<b>Chapter 13: Configuration Server.....</b>	<b>263</b>
Configuration Server overview.....	263
Language Support.....	264
Configuration Server installation.....	265
Creating or upgrading Configuration Server (ACS) Database.....	265
Backup / Restore / Delete databases.....	266
Starting Configuration Server.....	267
Configuration Manager overview.....	267
Logging to the database.....	268
Editing the Default Application template.....	269
Default Application template column descriptions.....	270
Creating New Application template.....	270
Add row for new application template field descriptions.....	272
Configuration filter properties.....	272
Adding configuration filter properties.....	272
Adding user to a database.....	273
Assigning a user to an application.....	274
Completing a user configuration.....	274
Assign multiple users to an application.....	275
Completing a user configuration.....	276

Live scenario.....	277
Creating different templates for different groups.....	278
Deleting a user configuration.....	278
Deleting a user from the database.....	279
Deleting an application template.....	279
Updating templates.....	279
Command Line parameters.....	280
Command Line parameter descriptions.....	280
Command Line Format.....	282
Configuration Data Commands.....	283
Token delimiter.....	283
Commands.....	283
Keywords.....	286
Literal data support.....	287
Nested commands.....	287
Recursive loop protection.....	287
Resolution precedence/reentrancy.....	288
Include directive.....	288
<b>Chapter 14: Interaction Data Service.....</b>	<b>289</b>
INCLUDE_CONFIGURATION.....	289
Interaction Data Service overview.....	289
Setting up Interaction Data Service.....	290
Configuring Interaction Data Server-Voice and Presence.....	291
Configuring Interaction Data Server - Multimedia.....	298
Configuring Interaction Data Server - View.....	303
Client Applications.....	308
Real Time Reporting Data.....	311
Device methods.....	311
SetDeviceStatusNotification.....	311
ClearDeviceStatusNotification.....	311
GetDeviceStatus.....	312
Device events.....	312
OnDeviceStatusNotified.....	312
Agent methods.....	313
SetRealtimeAgentNotification.....	313
ClearRealtimeAgentNotification.....	313
Agent events.....	313
OnRealtimeAgentStatusNotified.....	313
OnAgentLoggedIn.....	314
OnAgentLoggedOut.....	314
OnAgentStateChanged.....	315
VDN methods.....	315
SetRealtimeVDNNotification.....	315

ClearRealtimeVDNNotification.....	316
VDN events.....	316
OnRealtimeVDNStatusNotified.....	316
Queue methods.....	317
SetRealtimeQueueNotification.....	317
ClearRealtimeQueueNotification.....	317
Queue events.....	317
OnRealtimeQueueStatusNotified.....	317
Historical Reporting Data for Agent.....	318
Agent Methods.....	318
Agent events.....	318
Historical Reporting Data for Skill.....	319
Skill methods.....	319
Skill events.....	319
Historical Reporting Data for Queue.....	319
Queue methods.....	319
Queue events.....	319
Historical Reporting Data for Interaction.....	319
Interaction methods.....	319
Conversation and Customer.....	320
Conversation and Customer methods.....	320
Miscellaneous Capabilities.....	320
Miscellaneous capability methods.....	321
SetClientIdentity.....	321
SetConversationIDForInteraction.....	321
SetCustomerIDForInteraction.....	321
SetWorkCodeForInteraction.....	322
Enumerations.....	322
Reporting from AvayaCMS.....	322
<b>Chapter 15: Troubleshooting.....</b>	<b>333</b>
Troubleshooting Communication Manager Admin.....	333
Cannot establish the SSH connection to Communication Manager.....	333
<b>Appendix A: Log files in Call Center Elite Multichannel.....</b>	<b>335</b>
Classic Logging.....	335
Logging levels.....	336
Custom log level for diagnostic testing.....	337
TTrace Logging.....	337
TTrace server.....	337
TTrace console.....	338
TTrace config.....	338
TTrace Log2Zip.....	339
Error Logging.....	339
Configuring error logging.....	339

<b>Appendix B: Alarms and notifications</b> .....	341
Alarms.....	341
Changing alert state of an alarm.....	342
Notifications.....	343
License Director alarms.....	343
WebLM connection error alarm.....	343
License Director notifications.....	345
Service started.....	345
Service stopped.....	345
Media Director alarms.....	345
XML Link Down alarm.....	345
Media Director notifications.....	349
NotificationServiceStarted.....	349
NotificationServiceStopping.....	349
Queue Added.....	349
Queue Removed.....	349
Email Media Store alarms.....	349
AlarmMediaDirectorLinkDown.....	349
Email Media Store notifications.....	351
NotificationServiceStarted.....	351
NotificationServiceStopping.....	351
NotificationQueueAdded.....	351
NotificationQueueRemoved.....	352
Preview Contact Media Store alarms.....	352
AlarmMediaDirectorLinkDown.....	352
Preview Contact Media Store notifications.....	353
NotificationServiceStarted.....	353
NotificationServiceStopping.....	354
NotificationProgramStarted.....	354
NotificationProgramStopped.....	354
NotificationProgramScheduleChanged.....	354
Simple Messaging Media Store alarms.....	355
AlarmMediaDirectorLinkDown.....	355
Simple Messaging Media Store notifications.....	356
NotificationServiceStarted.....	356
NotificationServiceStopping.....	356
NotificationQueueAdded.....	356
NotificationQueueRemoved.....	356
AOL Messenger Gateway alarms.....	357
AlarmSMMSConnectionFailed.....	357
AOL Messenger Gateway notifications.....	357
NotificationServiceStarted.....	357
NotificationServiceStopping.....	357

NotificationRemoteServiceStarted.....	358
NotificationRemoteServiceStopped.....	358
Communicator Gateway alarms.....	358
AlarmSMMSConnectionFailed.....	358
Communicator Gateway notifications.....	359
NotificationServiceStarted.....	359
NotificationServiceStopping.....	359
NotificationRemoteServiceStarted.....	359
NotificationRemoteServiceStopped.....	359
MSN Messenger Gateway alarms.....	360
AlarmSMMSConnectionFailed.....	360
MSN Messenger Gateway notifications.....	360
NotificationServiceStarted.....	360
NotificationServiceStopping.....	360
NotificationRemoteServiceStarted.....	361
NotificationRemoteServiceStopped.....	361
SMS Gateway alarms.....	361
AlarmSMMSConnectionFailed.....	361
SMS Gateway notifications.....	362
NotificationServiceStarted.....	362
NotificationServiceStopping.....	362
NotificationRemoteServiceStarted.....	362
NotificationRemoteServiceStopped.....	362
Web Chat Gateway alarms.....	363
AlarmSMMSConnectionFailed.....	363
Web Chat Gateway notifications.....	363
NotificationServiceStarted.....	363
NotificationServiceStopping.....	363
NotificationRemoteServiceStarted.....	364
NotificationRemoteServiceStopped.....	364
GTalk Gateway alarms.....	364
AlarmSMMSConnectionFailed.....	364
GTalk Gateway notifications.....	365
NotificationServiceStarted.....	365
NotificationServiceStopping.....	365
NotificationRemoteServiceStarted.....	365
NotificationRemoteServiceStopped.....	365
Virtual Agent alarms.....	365
License Director Link Down alarm.....	365
Virtual Agent notifications.....	369
License Manager opened connection.....	369
VA maintaining started.....	369
DMCC Session Established.....	369

DMCC Endpoint Registered.....	370
DMCC Endpoint Monitored.....	370
DMCCGroupAssigned.....	370
DMCCGroupUnAssigned.....	370
DMCCGroupUpdated.....	370
Daily Maximum Endpoints Occupied.....	370
XML Server alarms.....	371
TServer Link Down alarm.....	371
XML Server notifications.....	373
NotificationServiceStarted.....	373
NotificationServiceStopping.....	373
TServer Link Up.....	373
<b>Appendix C: Configuration Files.....</b>	<b>374</b>
Configuring Control Panel through .ini file.....	374
ASGUIHost.ini file parameter descriptions.....	374
Configuring License Director through .ini file.....	383
ASLicenseDirector.ini file parameter descriptions.....	384
Configuring XML Server through .ini file.....	384
AXMLServer.ini file parameter descriptions.....	385
Configuring Media Director through .ini file.....	385
ASMediaDirector.ini file parameter descriptions.....	386
Configuring Virtual Agent through .ini file.....	388
ASVirtualAgent.ini file parameter descriptions.....	389
Configuring Email Media Store through .ini file.....	390
ASEmailMediaStore.ini file parameter descriptions.....	390
Configuring Preview Contact Media Store through .ini file.....	396
ASPreviewContactMediaStore.ini file parameter descriptions.....	397
Configuring Voice Media Store through .ini file.....	399
ASVoiceMediaStore.ini file parameter descriptions.....	400
Configuring Simple Messaging Media Store through .ini file.....	401
ASSimpleMessagingMediaStore.ini file parameter descriptions.....	401
Configuring AOL-ICQ Instant Messenger Gateway through .ini file.....	406
ASAIMGateway.ini file parameter descriptions.....	407
Configuring MSN Instant Messenger through .ini file.....	407
ASMSnMessengerGateway.ini file parameter descriptions.....	408
Configuring Short Message Service Gateway through .ini file.....	408
ASSmsGateway.ini file parameter descriptions.....	409
Configuring Web Chat Gateway through .ini file.....	409
ASWebChatGateway.ini file parameter descriptions.....	410
Configuring Communicator Gateway through .ini file.....	410
ASCommunicatorGateway.ini file parameter descriptions.....	411
Configuring GTalk Gateway through .ini file.....	411
ASXmppGateway.ini file parameter descriptions.....	412

<b>Appendix D: Common Configurable Components</b> .....	413
Application Management Service common configurable components.....	413
Client connections common configurable components.....	414
Contact database common configurable components.....	414
Error Logging common configurable components.....	415
Gateway Details common configurable components.....	416
Gateway Proxy Settings for common configurable components.....	417
Gateway Progress Messages common configurable components.....	417
IDS Media Store Plugin common configurable components.....	418
Media Director common configurable components.....	419
License Director common configurable components.....	419
Media Store common configurable components.....	420
Media Store Database common configurable components.....	420
Server Identifier common configurable components.....	421
Service Plug-in Host common configurable components.....	422
Simple Messaging Media Store common configurable components.....	422
XML Server common configurable components.....	422

# Chapter 1: Introduction

---

## Purpose

The guide describes how to administer Avaya Aura® Call Center Elite Multichannel. This guide also provides information about how to manage databases, configure various services in Call Center Elite Multichannel, and administer Avaya Aura® Communication Manager through Call Center Elite Multichannel Control Panel.

---

## Intended audience

This guide is intended for the sales engineers, solution architects, implementation engineers, and system administrators who configure Call Center Elite Multichannel for the agents, so that the agents can receive the voice and multimedia work items.

---

## Reasons for reissue

- Added a new section that describes Call Center Elite Multichannel database recommendation for high traffic systems.
  - Added a procedure to deploy report files.
  - Updated the procedure to install ODBC on a Windows client.
  - Added a procedure to add Designer in CMS Supervisor.
  - Added a procedure to run the CCE Queue Data Report.
- 

## What is new in this document?

In Avaya Aura® Call Center Elite Multichannel Release 6.3, the content from the following guides have been merged and added to the relevant sections and chapters:



Guide Name	Merged in Chapter
<i>Web Chat Gateway User Guide</i>	<a href="#">Services configuration</a> on page 30
<i>AOL-ICQ Instant Messenger Gateway User Guide</i>	<a href="#">Services configuration</a> on page 30
<i>Communicator Gateway User Guide</i>	<a href="#">Services configuration</a> on page 30
<i>Short Message Service Gateway User Guide</i>	<a href="#">Services configuration</a> on page 30
<i>MSN Messenger Gateway User Guide</i>	<a href="#">Services configuration</a> on page 30
<i>XMPP Gateway User Guide</i>	<a href="#">Services configuration</a> on page 30
<i>Preview Contact Media Store User Guide</i>	<a href="#">Services configuration</a> on page 30
<i>Simple Messaging Media Store User Guide</i>	<a href="#">Services configuration</a> on page 30
<i>Voice Media Store User Guide</i>	<a href="#">Services configuration</a> on page 30
<i>Email Media Store User Guide</i>	<a href="#">Services configuration</a> on page 30
<i>XML Server User Guide</i>	<a href="#">Services configuration</a> on page 30
<i>Virtual agent User Guide</i>	<a href="#">Services configuration</a> on page 30
<i>Media Director User Guide</i>	<a href="#">Services configuration</a> on page 30
<i>License Director User Guide</i>	<a href="#">Services configuration</a> on page 30
<i>Web Chat for IIS User Guide</i>	<a href="#">Services configuration</a> on page 30
<i>Database Deployment and Management User Guide</i>	<a href="#">Configuring Call Center Elite Multichannel databases</a> on page 23
<i>ASContact Database User Guide</i>	<a href="#">Contact database</a> on page 219
<i>Configuration Server User Guide</i>	<a href="#">Configuration Server overview</a> on page 263
<i>Interaction Data Service User Guide</i>	<a href="#">Interaction Data Service overview</a> on page 289

**\* Note:**

The guides listed in the table are now obsolete as the content from these guides have been merged in the *Administering Avaya Aura® Call Center Elite Multichannel*.

---

## Related resources

---

## Documentation

The following table lists the related documents for the Avaya Aura® Call Center Elite Multichannel product. You can download the documents from the Avaya Support website at <http://support.avaya.com/>.

<b>Title</b>	<b>Description</b>	<b>Audience</b>
<i>Avaya Aura® Call Center Elite Multichannel Call Routing Server User Guide</i>	Provides an overview of Call Routing Server that enables intelligent call routing for inbound calls in Call Center Elite Multichannel.	<ul style="list-style-type: none"> <li>• Sales engineers</li> <li>• Solution architects</li> <li>• Implementation engineers</li> <li>• System administrators</li> </ul>
<i>Installing Avaya Aura® Call Center Elite Multichannel</i>	Provides product overview, supported products, installation, configuration, and licensing requirements for Avaya Aura® Call Center Elite Multichannel.	<ul style="list-style-type: none"> <li>• Implementation engineers</li> </ul>
<i>Avaya Aura® Call Center Elite Multichannel Configuration Client Developer Guide</i>	Provides information about the Configuration Client Developer application, which is a control that facilitates an application to transparently access the configuration information from any location.	<ul style="list-style-type: none"> <li>• Programmers</li> </ul>
<i>Avaya Aura® Call Center Elite Multichannel Overview Guide</i>	Provides an overview of the Call Center Elite Multichannel features.	<ul style="list-style-type: none"> <li>• Sales engineers</li> <li>• Implementation engineers</li> <li>• System administrators</li> </ul>
<i>Avaya Aura® Call Center Elite Multichannel Desktop User Guide</i>	Provides information about Call Center Elite Multichannel Desktop and describes how to use Call Center Elite Multichannel Desktop to receive, view, and respond to voice and multimedia work items.	<ul style="list-style-type: none"> <li>• Sales engineers</li> <li>• Solution architects</li> <li>• Implementation engineers</li> <li>• System administrators</li> <li>• End users</li> </ul>
<i>Avaya Aura® Call Center Elite Multichannel Application Management Service User Guide</i>	Provides information about how to install and administer Application Management Service in Call Center Elite Multichannel.	<ul style="list-style-type: none"> <li>• Sales engineers</li> <li>• Solution architects</li> <li>• Implementation engineers</li> </ul>
<i>Avaya Aura® Call Center Elite Multichannel Upgrade and Migration Guide</i>	<p>Provides information about how to upgrade or migrate Avaya Aura® Call Center Elite Multichannel from Release 6.2.x to Release 6.3.1.</p> <p>The Upgrade Sequence section in the respective upgrading chapters provides a high-level overview of the process.</p>	<ul style="list-style-type: none"> <li>• Implementation engineers</li> <li>• Solution architects</li> </ul>

*Table continues...*

Title	Description	Audience
<i>Avaya Aura® Call Center Elite Multichannel Reporting User Guide</i>	Provides information about the reports for Agents, Customers, Interaction, Program and Schedule, Skills, and VDNs. This guide also provides information about historical reports and real-time reports.	<ul style="list-style-type: none"> <li>• Sales engineers</li> <li>• Solution architects</li> <li>• Implementation engineers</li> </ul>
<i>Avaya Aura® Call Center Elite Multichannel TTrace Console User Guide</i>	Provides an overview of the TTrace Console application.	<ul style="list-style-type: none"> <li>• Sales engineers</li> <li>• Solution architects</li> <li>• Implementation engineers</li> </ul>
<i>Installing TTrace Console for Avaya Aura® Call Center Elite Multichannel</i>	Provides information about how to install and configure TTrace.	<ul style="list-style-type: none"> <li>• Implementation engineers</li> </ul>

## Training

The following courses are available on the Avaya Learning website at <http://www.avaya-learning.com>. After logging in to the website, enter the course code or the course title in the **Search** field and press **Enter** or click **>** to search for the course.

Course code	Course title
5C00092W	Avaya Aura® Call Center Elite Multichannel Overview
10C00010E	Knowledge Access: Avaya Aura® Call Center Elite Multichannel Implementation
10C00094V	Avaya Aura® Call Center Elite Multichannel Implementation and Maintenance
4302	Avaya Aura® Call Center Elite Multichannel Implementation Test
0C00060E	Knowledge Collection Access: Avaya Aura® Call Center Elite Portfolio
E: Self-paced in virtual campus	
W: Web (online) course	
V: Virtual	

## Viewing Avaya Mentor videos

Avaya Mentor videos provide technical content on how to install, configure, and troubleshoot Avaya products.

### About this task

Videos are available on the Avaya Support website, listed under the video document type, and on the Avaya-run channel on YouTube.

## Procedure

- To find videos on the Avaya Support website, go to [support.avaya.com](http://support.avaya.com) and perform one of the following actions:
  - In **Search**, type `Avaya Mentor Videos` to see a list of the available videos.
  - In **Search**, type the product name. On the Search Results page, select **Video** in the **Content Type** column on the left.
- To find the Avaya Mentor videos on YouTube, go to [www.youtube.com/AvayaMentor](http://www.youtube.com/AvayaMentor) and perform one of the following actions:
  - Enter a key word or key words in the Search Channel to search for a specific product or topic.
  - Scroll down Playlists, and click the name of a topic to see the available list of videos posted on the website.

 **Note:**

Videos are not available for all products.

---

## Support

Go to the Avaya Support website at <http://support.avaya.com> for the most up-to-date documentation, product notices, and knowledge articles. You can also search for release notes, downloads, and resolutions to issues. Use the online service request system to create a service request. Chat with live agents to get answers to questions, or request an agent to connect you to a support team if an issue requires additional expertise.

# Chapter 2: Overview

Application Management Service manages and monitors all Media Stores, License Directors, XML Servers, and Media Directors in Call Center Elite Multichannel. Using Application Management Service, you can view the status of the servers, configure the servers in real time, manage the servers, and collect statistics. You can also use Application Management Service to add and manage the following data in ASMediastore Database:

- Programs
- Schedules
- Priority contacts
- Denied contacts
- Allowed contacts
- AutoText or Work Code
- Canned messages
- Advanced Work Code

Using Application Management Service, you can also add and manage data in ASContact Database.

## Related Links

[Components of Application Management Service](#) on page 21

---

## Components of Application Management Service

Application Management Service consists of the following two components:

- **Application Management Director:** An application that runs in a Microsoft Server environment and collects information about the status and condition of the Call Center Elite Multichannel servers.
- **Call Center Elite Multichannel Control Panel:** A component that connects to Application Management Director (AMD) to display the state of the available servers. This component is built using .Net Framework. Using this component, you can view and change the information related to configuration and operation of the servers.

When you start Application Management Director, Application Management Director opens a connection to all running Media Stores, License Directors, XML Servers, and Media Directors that

are connected to the network. After the connection is established, Application Management Director requests for the information related to the configuration and operation.

Application Management Director receives the information and sends the information to Call Center Elite Multichannel Control Panel. Call Center Elite Multichannel Control Panel displays the information in graphical tree structure.

Call Center Elite Multichannel Control Panel establishes a connection to Application Management Director. The connection is established using the multicast functionality, preconfigured data from the configuration set, or both. After the connection is established, Call Center Elite Multichannel Control Panel mentions it as a management interface, and requests Application Management Director to send a complete list of available information. Call Center Elite Multichannel Control Panel receives a collection of XML documents and displays the information within a hierarchical node structure.

 **Note:**

This document provides information about the configuration and operation of Call Center Elite Multichannel Control Panel. For more information about configuring AMD, see *Avaya Aura® Call Center Elite Multichannel Application Management Service User Guide*.

### Related Links

[Overview](#) on page 21

# Chapter 3: Configuring the Call Center Elite Multichannel databases

Using the Database Deployment and Management plug-in, you can deploy and manage the Call Center Elite Multichannel databases. When you create the database, you must use a user name and password with administrator privileges in the first instance.

## \* Note:

The Interaction Data Server database uses the Media Store databases namely ASMSControl and ASMSData. You can deploy the Interaction Data Server and Configuration Server databases using the batch files. The Interaction Data Server and Configuration Server databases are not the parts of the Database Deployment and Management plug-in solution. You cannot deploy the batch files to a remote database server.

---

## Creating databases

### About this task

Using this procedure, you can create a new database from the **Database Management** node, the **Contact Database** node, or the **Media Store Database** node.

### Procedure

1. Start Call Center Elite Multichannel Control Panel.
2. Perform one of the following steps:
  - In the left pane, right-click **Database Management**, click **Create New Database**, and then click **ASMSControl** or **ASContact**.
  - In the left pane, expand the **Database Management** node, right click **Media Store Database** or **Contact Database**, and then click **Create New Database**.

The system displays the **Database Utility - Database Creation Agent** tab.

3. Click the ellipses (...) button next to the **Database server name** field to search the available SQL database servers on the network.

The system adds all the available database server names in the **Database server name** field.

4. In the **Database server name** field, perform one of the following steps:
  - Enter the server name where you want to create a new database.
  - From drop-down list, click the server where you want to create a new database.
5. In the **User name** field, enter a user name to access the new database.
6. In the **Password** field, enter a password to access the new database.

**\* Note:**

Ensure that you configure SQL Server for the mixed mode authentication and not the Windows only authentication. The mixed mode authentication specifies that you have configured SQL Server for Windows and SQL Server. If you are using SQL Server authentication, you must enter the user name and password of the SA account.

7. Click **Create**.

You can view the database creation process in the **Status** field.

---

## Creating a new ASMSDataX database

### About this task

A new database structure replaces the previous media store databases. The new database subsystem is fronted by the **ASMSControl** database. This in turn spawns and manages a series of **ASMSDataX** databases, where X= 1, 2, 3, ... n.

This mechanism provides an instant archival system that writes data only one time. The Reporting function and the other data retrieval functions address the **ASMSControl** database that determines the group of **ASMSDataX** databases to examine. The data retrieval process takes place across these databases. All Media Stores and other database addressing servers write only to the **ASMSControl** database.

### Procedure

1. Start Microsoft SQL Server Management Studio.
2. In the left pane, expand the **Databases** node.
3. Right-click the **ASMSControl** node and click **New Query**.
4. In the right pane, type the following SQL query to create a new database.

```
USE [ASMSControl]
GO
DECLARE @return_value int
EXEC @return_value = [dbo].[PrepareNextASMSDataDatabase]
@FromDateTime = N'2009/11/01 00:00' /**** <== change this date ****/
SELECT 'Return Value' = @return_value
GO
```



**\* Note:**

You must add the time in database script as GMT time (+0:00)

5. Set a value for the `FromDateTime` parameter.
6. Right-click anywhere in the right pane and click **Execute**.

Call Center Elite Multichannel writes all the new data to the new **ASMSDataX** database.

---

## Removing an old ASMSDataX database

### About this task

To remove an old **ASMSDataX** database with SQL Server Management Studio:

### Procedure

1. Take a backup of the **ASMSDataX** database.
2. Take a backup of the **ASMSControl** database.
3. Start Microsoft SQL Server Management Studio.
4. In the left pane, expand the **Databases** node.
5. Expand the **ASMSControl** node
6. Expand the **Tables** node
7. Right-click the **dbo.Databases** node and click **Design**.
8. In the right pane, for the record with the database name as **ASMSDataX**, set **0** in the **DatabaseOnline** column.
9. Right-click the **ASMSDataX** database and click **Delete**.
10. Select the **Close existing connections** check box.
11. Click **OK**.

---

## Viewing database management options

### About this task

Using this procedure, you can view information about a database configured for Media Store Database and Contact Database.

### Procedure

1. Start Call Center Elite Multichannel Control Panel.
2. In the left pane, expand the **Database Management** node.

3. Expand the **Media Store Database** or **Contact Database** node.
4. Click the respective database node to view the details.

In the right pane, the system displays the following information on the **Summary** tab:

- Database Details
  - Database name
  - Database Server name
  - Database user name
  - Database version
  - Database size
  - Unallocated space
  - Connection state
- Tables
  - Name
  - Rows
  - Reserved
  - Data
  - Index Size
  - Unused
- Update history
  - Modify Date Time
  - Key
  - Value

 **Note:**

When you click a database node, the system displays the information of each ASMSData Database in a new tab within the main tab.

---

## Call Center Elite Multichannel databases recommendation for high traffic systems

Call Center Elite Multichannel uses the ASMSControl, ASMSDataX, ASContact, and Configuration Server databases. If you have deployed Microsoft SQL Server on C:\ drive and created the databases through Call Center Elite Multichannel Control Panel, ensure that:

- The system that hosts Microsoft SQL Database contains at least two partitions.

- The tmp database has a minimum size of 5 GB.
- The database contains a secondary file group with a physical file.
- The secondary file group is the default file group.
- The Auto Shrink property is set to `False`.

---

## Configuring the tmp database

### About this task

Using this procedure, you can configure the tmp database.

### Procedure

1. Log in to database server through Remote Desktop Connection.
2. Start Microsoft SQL Server Management Studio and connect to the database.
3. In the left pane, expand the **Databases** node.
4. Expand the **System Databases** node.
5. In the **System Databases** node, right-click the **tempdb** node and click **Properties**.
6. In the Database Properties - tempdb dialog box, perform the following steps:
  - a. In the left pane, click **Files**.
  - b. In the row where the **File Type** field is set to `Rows Data`, enter the value `5000` in the **Initial Size (MB)** field.
  - c. In the row where the **File Type** field is set to `Log`, enter the value `500` in the **Initial Size (MB)** field.
  - d. In the left pane, click **Options**.
  - e. In the **Auto Shrink** field, set the value to `False`.
  - f. Click **OK**.

---

## Configuring file groups

### About this task

Using this procedure, you can add a secondary file group to a database.

### Procedure

1. Log in to the database server through Remote Desktop Connection.
2. Start Microsoft SQL Server Management Studio and connect to the database.
3. In the left pane, expand the **Databases** node.
4. In the **Databases** node, right-click the **ASMSData1** node and click **Properties**.

5. In the Database Properties - ASMSData1 dialog box, perform the following steps:
  - a. In the left pane, click **Filegroups**.
  - b. Click **Add**.
  - c. In the **Name** field, enter the value `Secondary`.
  - d. Click **OK**.
6. In the **Databases** node, right-click the **ASMSData1** node and click **Properties**.
7. In the Database Properties - ASMSData1 dialog box, perform the following steps:
  - a. In the left pane, click **Files**.
  - b. In the row where the **File Type** field is set to `Rows Data`, enter the value `5000` in the **Initial Size (MB)** field.
  - c. In the row where the **File Type** field is set to `Log`, enter the value `500` in the **Initial Size (MB)** field.
  - d. Click **Add**.
  - e. In the **Logical Name** field, enter the value `ASMSData1Sec`.
  - f. In the **Filegroup** field, set the value to `Secondary`.
  - g. In the **Initial Size (MB)** field, enter the value `10000`.
  - h. Click the ellipses (...) button next to the **Autogrowth** field.

The system displays the Change Autogrowth dialog box.
  - i. Select the **Enable Autogrowth** check box.
  - j. In the **File Growth** field, select the **In Megabytes** option and enter the value `2000` in the text box.
  - k. In the **Maximum File Size** field, select the **Unlimited** option.
  - l. Click **OK**.
  - m. In the **Path** field, select a path for the file.

Ensure that the path that you select is different from the path where other files are present. This action is mandatory for high-load systems
  - n. In the **File Name** field, enter the value `ASMSData1.mdf`.
  - o. Click **OK**.

---

## Turning off Auto Shrink

### About this task

Using this procedure, you can turn off the Auto Shrink property.

## Procedure

1. Log in to database server through Remote Desktop Connection.
2. Start Microsoft SQL Server Management Studio and connect to the database.
3. In the left pane, expand the **Databases** node.
4. In the **Databases** node, right-click the **ASMSData1** node and click **Properties**.
5. In the Database Properties - ASMSData1 dialog box, perform the following steps:
  - a. In the left pane, click **Options**.
  - b. In the **Auto Shrink** field, set the value to `False`.
  - c. Click **OK**.

---

## Setting the secondary file group as default

### About this task

Using this procedure, you can set the secondary file group as the default file group.

### Procedure

1. Log in to database server through Remote Desktop Connection.
2. Start Microsoft SQL Server Management Studio and connect to the database.
3. In the left pane, expand the **Databases** node.
4. In the **Databases** node, right-click the **ASMSData1** node and click **Properties**.
5. In the Database Properties - ASMSData1 dialog box, perform the following steps:
  - a. In the left pane, click **Filegroups**.
  - b. In the Secondary row, select the **Default** check box.
  - c. Click **OK**.

# Chapter 4: Services configuration

---

## Start, configure, and monitor services

In Call Center Elite Multichannel, you can configure and monitor services using Application Management Service (AMS). A component of AMS called Call Center Elite Multichannel Control Panel serves as a user interface and facilitates you to add and change the configuration and operation information of the monitored servers.

Using Call Center Elite Multichannel Control Panel, administrators can quickly find and configure a service. Call Center Elite Multichannel Control Panel has two panes. The left pane displays all installed services in Call Center Elite Multichannel and the right pane displays the configuration options for the selected service.

Call Center Elite Multichannel Control Panel connects to AMD and the AMD connects to all Media Stores, Media Directors, License Directors, and XML Servers. Call Center Elite Multichannel Control Panel collects the configuration information from AMD and displays the information in a tree structure.

When you install a service and view summary of the service for the first time, Call Center Elite Multichannel Control Panel displays the status of the service as **Running**. If you do not see the status of a service as **Running**, you must start the service through Windows Services. After AMD updates the information of a service, you can start and stop that service from Call Center Elite Multichannel Control Panel.

You can also configure Avaya Aura<sup>®</sup> Communication Manager to select objects such as the agents, stations, and Vector Directory Numbers (VDNs) that are configured for Call Center Elite Multichannel. To configure Avaya Aura<sup>®</sup> Communication Manager through Call Center Elite Multichannel Control Panel, you must correctly configure the Communication Manager Administration (CM Admin) plug-in.

### Related Links

[Communication Manager administration](#) on page 32

---

## Starting a Call Center Elite Multichannel service

### About this task

Using this procedure, you can start a Call Center Elite Multichannel service.

## Procedure

1. Click **Start > Control Panel**.
2. Click **Administrative Tools**.
3. Double-click **Services**.
4. Right-click each of the following Call Center Elite Multichannel services and click **Start**.
  - AS AOL-ICQ Instant Messenger Gateway
  - AS Application Management Director
  - AS Call Routing Server
  - AS Email Media Store
  - AS Interaction Data Service - Multimedia
  - AS Interaction Data Service - View
  - AS Interaction Data Service - Voice and Presence
  - AS IVR Server
  - AS Media Proxy Service
  - AS MSN Messenger Gateway
  - AS Preview Contact Media Store
  - AS Short Message Service Gateway
  - AS Simple Messaging Media Store
  - AS Web Chat Gateway
  - AS XML Server

---

## Starting Call Center Elite Multichannel Control Panel

### About this task

Using this procedure, you can start Call Center Elite Multichannel Control Panel.

### Procedure

1. Click **Start** on the Windows Task bar
2. Click **All Programs > Avaya Aura CC Elite Multichannel > Desktop > CC Elite Multichannel Control Panel**.

---

## Communication Manager administration

Communication Manager Administrator (CM Admin) is a plug-in using which you can view and configure the Communication Manager components for Call Center Elite Multichannel.

To view and configure the settings, you must configure the Communication Manager connection by specifying the details of Communication Manager Server. After you configure the connection, you can view Communication Manager components, such as agents, VDNs, stations, and skills.

---

## Security Warning Banner

Using the Security Warning Banner feature, you can configure a security warning for a system where Call Center Elite Multichannel Control Panel is installed. In the security warning, you can configure a message to inform the user about how to use a Call Center Elite Multichannel application, such as Call Center Elite Multichannel Control Panel.

The system displays this security warning every time you log in to the system.

---

## Configuring security warning banner

### Procedure

1. Start Call Center Elite Multichannel Control Panel.
2. Click **Tools > Options**.
3. In the Options dialog box, click the **Security Banner** tab.
4. Select the **Enable Security Banner** check box.
5. In the **Legal Notice Caption** field, enter a title for the security warning.
6. In the **Legal Notice Text** field, enter the security warning message.
7. Click **Apply** and then click **OK**.

---

## Call Recording

Using the Call Recording feature in Call Center Elite Multichannel, agents can record their conversations with the customers. You can view the summary of call recording service and configure the controllers for call recording in Call Center Elite Multichannel Control Panel. For information about how to record a call, see *Avaya Aura® Call Center Elite Multichannel Desktop User Guide*.



**!** Important:

Before you configure call recording in Call Center Elite Multichannel Control Panel, ensure that you install Avaya Contact Recorder (ACR) and configure the recording ports on Call Recording Server.

---

## Configuring Call Recording Controller

### Procedure

1. Start Call Center Elite Multichannel Control Panel.
2. In the left pane, expand the **Call Recorders** node.
3. Expand the **CallRecording** node.
4. Right-click the **Controller** node and click **Edit**.

The system displays the **Edit Controller** tab in the right pane.

5. In the **Avaya Call Recorder URL Configuration** section, enter values in the following fields:
  - a. In the **Machine Name or IP Address** field, enter the IP address or host name of the server where the call recorder is installed.
  - b. In the **Port** field, enter the port number to access the call recording for administration.

**\* Note:**

To enable the Replay Recording option in Call Center Elite Multichannel Desktop, ensure that you specify the correct IP address and port number of Call Recording Server, so that the agents can replay the recorded calls. You can also specify the IP address and port number of Call Recording Server in the `Avaya Call recording service.ini` file of Call Recording Config Service.

6. In the **Error Logging** section, enter appropriate values in the fields.
 

For description of the fields in the **Error Logging** section, see [Error Logging](#) on page 339.
7. Right-click anywhere on the **Edit Controller** tab and click **Save and Close**.
8. In the left pane, right-click the **CallRecording** node and click **Stop Service**.
9. In the right pane, click the **Summary** tab and check the **Service status** field to ensure that the system has stopped the service.
10. In the left pane, right-click the **CallRecording** node and click **Start Service**.
11. In the right pane, click the **Summary** tab and check the **Service status** field to ensure that the system has started the service.
12. Click the **Controller** node.

The system displays the recording ports that are available for agents to record a call. The **Avaya Call Recorder URL Configuration** section displays the URL that is configured for Call Recording Server.

13. Click the **Avaya Call Recorder URL Configuration** link.
14. On the Call Recording Server administration page, perform the following steps to log in to Call Recording Server:
  - a. Enter the user name and password.
  - b. Click **OK**

---

## License Director

License Director is a central repository for all Call Center Elite Multichannel run-time licenses. License Director polls the licenses from WebLM Server.

License Director manages licensing by accepting license requests from the Call Center Elite Multichannel applications. License Director issues only the number of licenses that you purchase or make available for trial. If the number of licenses requested exceeds the number of purchased licenses, the license request is denied.

The numbers of purchased run-time licenses are encrypted in a WebLM license file which is installed on WebLM Server.

---

## Types of license keys

The following are the types of license keys:

- VALUE\_CCM\_VOICE
- VALUE\_CCM\_MULTICHANNEL
- VALUE\_CCM\_CRM

The VALUE\_CCM\_VOICE license is required for the following:

- Call Center Elite Multichannel Desktop when used for voice, multimedia, or both - one voice license for each logged in agent
- Call Center Elite Multichannel Reporting Desktop - one voice license
- Voice Media Store - one voice license
- Media Director - one voice license
- Virtual agents
- Applications that are built using Call Center Elite Multichannel Developer

XML Server requests licenses for the mentioned applications.

**\* Note:**

A single VALUE\_CCM\_VOICE WebLM key includes all voice licenses. The VALUE\_CCM\_VOICE WebLM key covers all voice applications that you want to use within your call center environment. To add more users or applications, you must upgrade your WebLM license and reinstall the WebLM license on WebLM Server.

The VALUE\_CCM\_MULTICHANNEL license is required for the following:

- Call Center Elite Multichannel Desktop for multimedia users. To use all voice and multimedia functionalities of Call Center Elite Multichannel Desktop, you must have the following:
  - One Call Center Elite Multichannel multimedia license key with run-time licenses to cover the number of logged in agents who use Call Center Elite Multichannel Desktop
  - One Call Center Elite Multichannel voice license key with the same number of run-time licenses
  - Virtual agents

The VALUE\_CCM\_CRM license is required for the following:

- Microsoft Dynamics CRM connector - one Call Center Elite Multichannel Microsoft Dynamics license key provisioned in the WebLM license

This single license key covers as many agents as the number of run-time voice licenses.

**\* Note:**

License Director in Call Center Elite Multichannel does not provide uncounted licenses, therefore, License Director shows the same number of CCM\_CRM and CCM\_VOICE licenses.

After installation, License Director has no direct user interaction.

You can add, delete, and modify license information through WebLM Server. For more information, see [WebLM server overview](#) on page 38.

---

## License Director overview

License Director automatically starts when you start a server containing License Director. Based on the configuration of Call Center Elite Multichannel Control Panel, License Director extracts and reads all license keys. You can view the licenses through Call Center Elite Multichannel Control Panel or WebLM Administration. The license file is stored in the `<tomcat_home>\webapps\WebLM\licenses` directory on WebLM Server, which can coexist with Call Center Elite Multichannel. Each key is encrypted with the license expiration, number of concurrent licenses, and license holder.

When you start a Call Center Elite Multichannel application, the application automatically connects to License Director and requests for a license. If the number of issued licenses is less than the number of purchased licenses, License Director issues the license along with a unique run-time license number.

After the license is issued for the application, the application automatically checks in with the server in every three minutes to inform License Director that the application is still in use. When you close the application, the application automatically sends a release license request to License Director. After receiving the release license request, License Director releases the license to the available license pool.

If the check in time between License Director and application is more than six minutes, License Director marks the license number as invalid and releases the license back into the available license pool. The delay can be because the client PC has crashed or the server running License Director is too busy to process the request.

## License Director in WebLM mode

The following diagram depicts how License Director operates in WebLM mode.

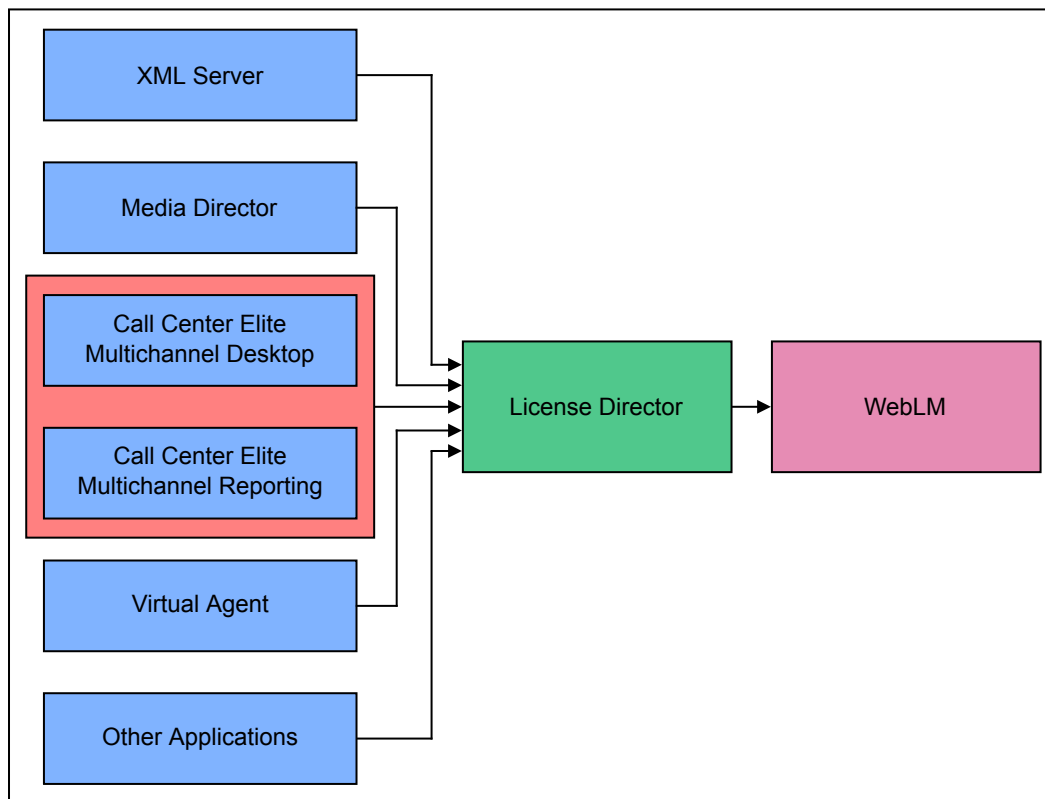

---

## Licensing error messages

Call Center Elite Multichannel application displays an error message when one of the following occurs:

- The license key is not set up using Application Management Service.
- The application license is a trial license and has expired.

- The number of run-time licenses requested exceeds the total number of licenses purchased.
- Either the server running License Director or the License Director is unavailable.

---

## Distribution of license servers

If you have multiple License Directors running at multiple sites, you can configure your Call Center Elite Multichannel environment to share licenses. If one License Director runs out of the local licenses and the clients ask for more licenses, the License Director requests for licenses from the master server.

### Note:

You must specify the master server while configuring License Director.

A License Director that works as a master server can specify another License Director as master server. It implies that a chain can be set up to share licenses among a group of servers.

In case of multiple sites, you must assign each License Director to a separate WebLM Server.

---

## Checklist for implementing and administering License Director

The following checklist outlines the steps that you must perform to implement and administer Call Center Elite Multichannel License Director.

Step	Task	✓
1	Install Application Management Service and start Application Management Director through Windows Services	
2	Install WebLM Server	
3	Install License Director	
4	Start Call Center Elite Multichannel Control Panel If you do not see License Director in Call Center Elite Multichannel Control Panel, start the License Director service through Windows Services.	
5	Configure and maintain License Director using Call Center Elite Multichannel Control Panel	

---

## Viewing license keys

### About this task

Using this procedure, you can view the available license keys for a License Director.

### Procedure

1. Start Call Center Elite Multichannel Control Panel.

2. In the left pane, expand the **License Directors** node.
3. Expand the **License Director** node.
4. Click the **License Keys** node to view the available license keys.

---

## WebLM Server overview

WebLM Server is a repository that stores the licenses and from which License Director polls the licenses. You can install WebLM Server either on the same server where Call Center Elite Multichannel is installed, or on a standalone server in the network. License Director checks out licenses when WebLM Server starts and releases licenses when WebLM Server shuts down. When the connection between WebLM Server and License Director breaks:

- WebLM Server does not receive new requests from License Director and after a timeout period of 600 seconds, WebLM Server releases the checked out licenses.
- License Director fails to send new requests. Also, License Director immediately releases all checked out licenses and tries to check out the licenses again every 30 seconds.

You can see Call Center Elite Multichannel listed in the **Licensed Products** node in WebLM.

---

## Adding licenses to WebLM Server

### About this task

After you install WebLM Server on the system, you can add the required licenses to WebLM Server.

### Procedure

1. In Internet Explorer, type the URL of the WebLM Server that you configured during the installation of WebLM Server.

The default URL is: `https://<WebLM_server_name>:52233/WebLM/LicenseServer`.

2. Click **License Administration**.
3. Enter the user name and password to access WebLM Server.
4. Click **Browse** and select the license file for Call Center Elite Multichannel.
5. Click **Install**.

The licenses for Call Center Elite Multichannel are installed on WebLM Server.

6. In the left pane, click the **CALL\_CENTER\_ELITE\_MULTICHANNEL** node to view the installed licenses.

---

## XML Server

XML Server is a link between Application Enablement Server (AES) and the Call Center Elite Multichannel applications that are developed in Microsoft .Net.

XML Server sends a signal to AES to pass the call control and call event information to Call Center Elite Multichannel applications, such as Call Center Elite Multichannel Desktop. AES receives the same information from Call Center Elite Multichannel Desktop.

XML Server is a Windows service that starts when you start the operating system. On startup, XML Server retrieves all configuration data from the local configuration file.

Each XML Client that connects to XML Server opens a corresponding link to a Telephony Server. This connection opens using a single user name and password provided in the configuration data. The supplied user name or password combination enables access to all appropriate Avaya Communication Manager devices through the security database.

XML Server supports connections to multiple Telephony Servers.

---

## XML Service

XML Service consists of XML Server that converts the CSTA II interface of TSAPI software to CSTA III XML and XML Client by which developers can build CTI applications in .Net.

This CSTA XML-over-TCP interface complies with ecma-269, ecma-285, and ecma-323 (specifically as described in Annex G of the Standard ECMA - 323 June 2001, XML Protocol for Computer Supported Telecommunications Applications (CSTA) Phase III.)

---

## XML Client

XML Client is distributed as part of the Developer toolkit. XML Client provides a CSTA III XML interface by which developers can build Windows-based CTI applications in Microsoft Visual .Net or Visual C#.

XML Client encompasses four developer components, namely, XML Client, XML Station, XML Routing, and XML VDN.

- XML Client is the core component that communicates with XML Server. Representing the base-level XML/CSTA tier, developers can use exposed objects of XML Client to directly implement telephony operations. Developers can also treat it as a data source when using higher-level, device-tier components, such as XML Station, XML Routing, and XML VDN.
- XML Station binds with XML Client to perform telephony operations on a voice station and manage the calls. The objects exposed by XML Station saves the active calls on the voice station. XML Station then lets the users to handle calls through a set of methods at the call appearance level.
- XML Routing binds with XML Client to perform the telephony operations on a registered VDN and manage the routing calls.

- XML VDN binds with XML Client to monitor VDNs (vector directory numbers) and receive call events of VDNs.

The base XML/CSTA tier includes the methods and events that communicate directly with XML Server in XML. You require more coding when working with XML/CSTA tier, but you can send your customized XML requests to the server.

The device tier does not deliver that level of control, but offers more functionality with less coding. A set of methods at the call appearance level makes it easy to control active calls.

For information on the methods and events exposed by XML Client (ASXMLClient.dll), see the `Call Center Elite Multichannel Developer Reference.chm` HTML Help file placed in the `\Avaya Aura CC Elite Multichannel\Developer` directory.

The following diagram depicts the work flow of XML Client.

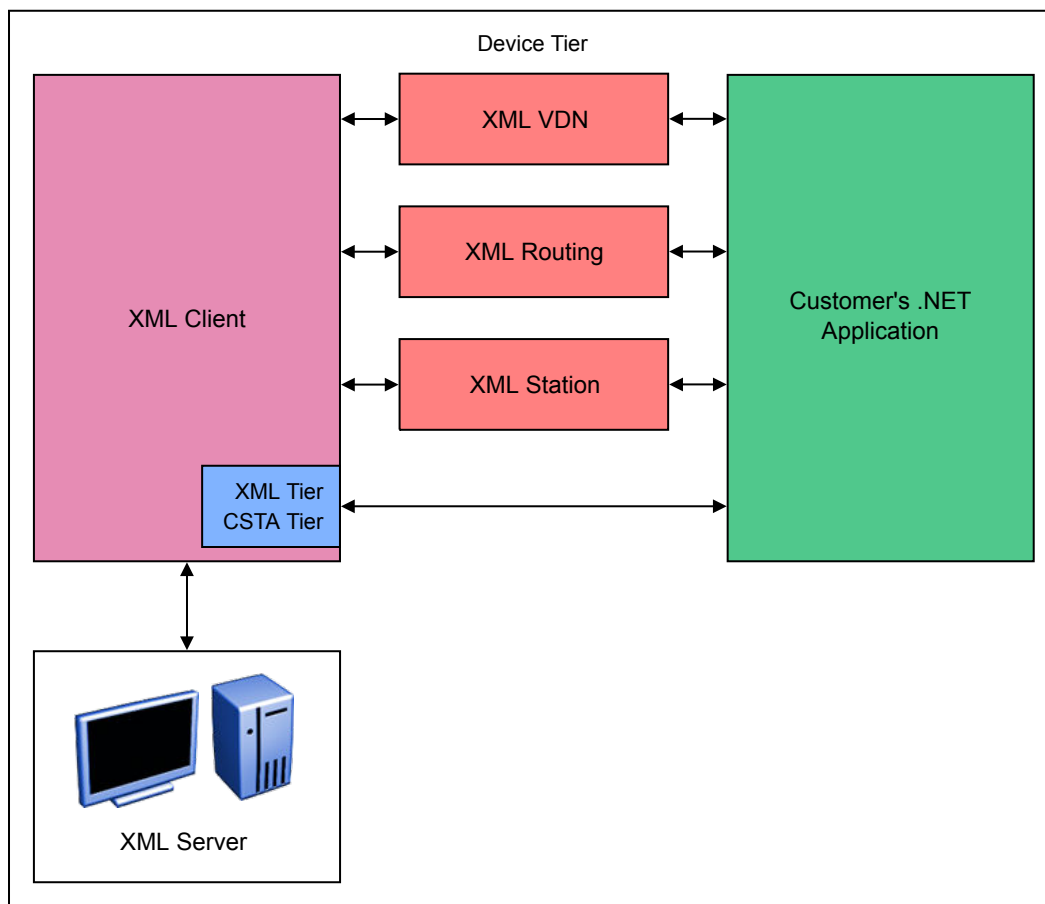

## Support for Non-Windows Clients

Operating systems such as Linux, Solaris, and Unixware have strong native support for XML document handling or readily available additional modules. You must develop your XML Client control to communicate with XML Server and run on one of the operating systems.



---

## Licensing for XML Server

### About this task

To use XML Server, you must buy a license key or upgrade your Call Center Elite Multichannel voice license key with enough run-time licenses. The run-time licenses cover a number of client applications that connect to XML Server.

### Procedure

1. Install the WebLM license files which include the license keys on WebLM Server.
2. Using Call Center Elite Multichannel Control Panel, add license keys to License Director.

### Related Links

[Adding licenses to WebLM Server](#) on page 38

---

## XML Server error messages

When XML Server starts, an error message displays when one of the following occurs:

- The license key is not set up using the Application Management Service.
- The license is a trial-only license and has expired.
- The number of run-time licenses requested exceeds the total number of licenses purchased.
- Either the server running License Director or the License Director is unavailable.

For information about how XML Server interacts with License Director, see [License Director](#) on page 34.

---

## XML Server configuration overview

On startup, XML Server extracts the information required to run through the `AXMLServer.ini` configuration file.

This configuration file must include the following:

- The IP address and port number of the XML naming service where the clients connect for a list of configured XML interfaces.
- The IP addresses and port numbers of the XML interfaces that are responsible for converting the CSTA II interface of TSAPI software to CSTA III XML and vice versa.
- The names of Telephony Servers available for the service.

The following is the work flow of XML Server and Telephony Server:

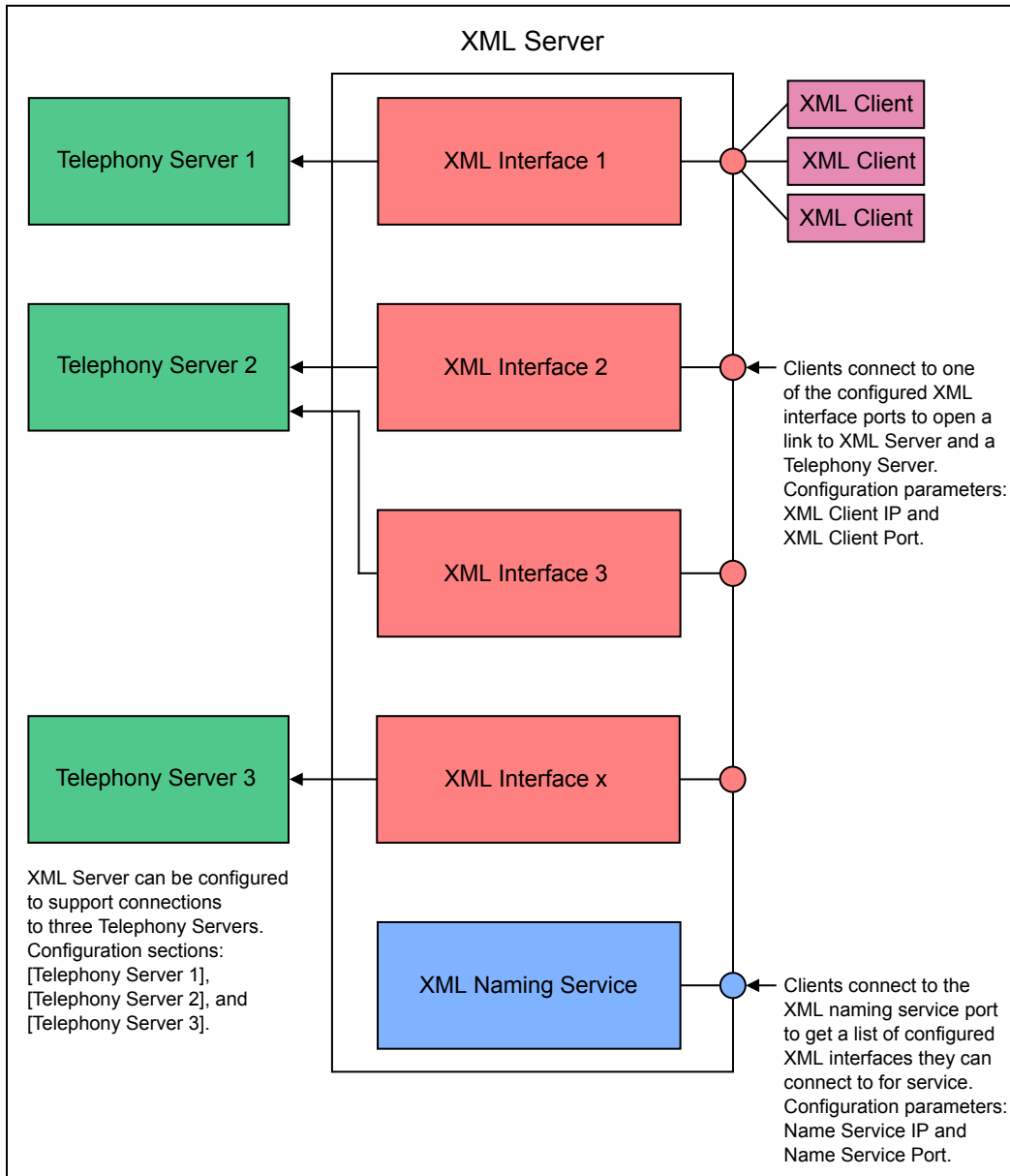

## Checklist for implementing and administering XML Server

The following checklist outlines the series of steps to implement and administer Avaya Aura® Call Center Elite Multichannel XML Server.

Step	Task	✓
1	Install Application Management Service and start Application Management Director through Windows Services	

*Table continues...*

Step	Task	✓
2	Install XML Server	
3	Start Call Center Elite Multichannel Control Panel If XML If you do not see XML Server in Call Center Elite Multichannel Control Panel, start the XML Server service through Windows Services.	
4	Configure and maintain XML Server using Call Center Elite Multichannel Control Panel	

## Adding a Telephony Server to XML Server

### Procedure

1. Start Call Center Elite Multichannel Control Panel.
2. In the left pane, expand the **XML Servers** node.
3. Expand the **XML Server** node.
4. Right-click the **Telephony Servers** node and click **Add Telephony Server**.
5. On the **Add Telephony Server** tab, enter appropriate values in the fields.

For information about the fields on the **Add Telephony Server** tab, see [Add Telephony Server field descriptions](#) on page 43.

6. In the right pane, right-click anywhere on the **Add Telephony Server** tab and click **Save and Close**.

### Add Telephony Server field descriptions

Name	Description
<b>Enable Telephony Server</b>	The check box to connect the XML server to the telephony server.
<b>Friendly name</b>	The name that you want to display for a telephony server.
<b>Tlink name</b>	The link that the telephony server uses to connect to the telephony server and the switch.
<b>Tlink user name</b>	The user name required to access the link.
<b>Tlink user password</b>	The password associated with the user name.
<b>XML client IP</b>	The IP address of the configured XML interface on an XML server.
<b>XML client port</b>	The port number of the configured XML interface on the XML server.  The XML client uses this IP address and port to open a link to the XML server and connect to the telephony server.

*Table continues...*

Name	Description
	<p>If you keep the <b>XML client IP</b> field blank, the XML server accepts connections on any configured IP address in the operating system of the XML server.</p> <p>You can set the port to any value, such as 0 or 29097. You can also let the operating system on the XML server to decide the port from the pool of free ports between 1024 and 5000.</p> <p>If the XML server decides the port, the XML client must use the naming service to gather information of XML client connection.</p>
<b>Perform agent events challenge</b>	The check box to enable the XML server to request agent events from Communication Manager.
<b>Perform named licensing challenge</b>	The check box to enable named licensing between the XML server and AES.
<b>Name service response IP</b>	The IP address or host name that is returned, when the name service requests come.

**! Important:**

To use named licenses and enable agent events, you must configure a secure TLink (CSTA-S).

---

## Media Director

Media Director distributes non-voice work items such as an email, a web chat session, or an outbound call request to contact center agents. The queuing algorithms built in to your Avaya Communication Manager manage the distribution of the work items. Non-voice work items originate from plug-in modules called Media Stores. Media Stores connect to disparate sources such as email servers or web servers and interact with the Media Director and clients using a well-defined protocol.

Media Director acts as an engine to queue multimedia work items before sending the items to the respective agents for processing. Media Director also stores the locations where work items are to be delivered.

Call Center Elite Multichannel Desktop communicates with Media Director through Media Proxy. Call Center Elite Multichannel Desktop provides the IP address of the system, station number, and agent ID associated with the system to Media Director.

To deliver a work item, Media Director instructs the application about how to connect to the correct Media Store and where to find the work item.

Media Director uses the phantom call capabilities of a switch to generate a call and queue the call to a specific skill. Phantom calls are generated by a CTI application that has no physical station as the originating point. The switch distributes the phantom call using standard queuing algorithms and blends the phantom call with other traditional voice calls. When the phantom call is delivered to an

agent, the Media Director associates the phantom call with the highest-priority work item and allows data specific to the work item to be transferred to the agent desktop.

## Media Stores

A Media Store receives information from one type of media source and requests the information be queued by Media Director into different queues. For example, an Email Media Store can support multiple mail boxes with each mail box requiring a separate queue.

## Application set

An application set such as Media Director, Media Client, Media Proxy, and range of Media Stores is developed using Microsoft .Net environment. Extensive use is made of the remoting architecture to distribute work item objects created in the Media Stores to clients through the Media Director.

## Related Links

[Media Stores overview](#) on page 73

---

## Work items

When an agent receives a work item, the agent can view the requirements of the job, such as customer-specific information available in the Media Store. The agent can also view the following general work item information:

- The ID of the queue where the work item is queued.
- The type of the work item.
- The ID of the work item.
- The ID of the contact. The ID can be a name or company name.
- Information specifying whether the work item is transferred to an agent or this queue.
- Information specifying the ID of the agent whom the work item is transferred to. This information is displayed only if the work item is transferred to an agent.
- Additional contact information in form of key or value pairs.

---

## Avaya Communication Manager algorithms

To use Avaya Communication Manager algorithms, you must configure your Avaya Communication Manager with extension numbers that are known as phantom stations. Phantom stations have the same characteristics as a physical telephone handset. Using phantom stations, an external application can make calls, receive calls, transfer calls, and conference calls.

### Note:

In Avaya Communication Manager, the station type for phantom stations is **cti**.

The ability to make a call from a phantom station specifies that an application can put a call into a contact center queue without a live caller or a real phone. After putting the call into a skill queue by dialing a VDN number assigned to the vector that queues the call, Avaya Communication Manager

uses the internal queuing mechanism to deliver the call to the next available agent. The call is answered after the call reaches the agent handset. After the completion of work, the agent is available for the next call from the queue.

Distributing calls to agents using the phantom call mechanism has several advantages:

- Avaya Communication Manager queuing algorithms are well proven and need not be replicated.
- Non-voice work items blends with traditional voice calls by which non-voice can fill in the gaps at a lower priority than voice calls.

If Call Center Elite Multichannel Desktop Utility Plug-in is enabled and certain information that comes with the work item is set to `True`, the phantom call in the work item drops when the agent accepts the work item. This action places the agent into pending Auxiliary mode, preventing the agent from receiving other work items, other queues, or traditional voice traffic.

If Desktop Utility Plug-in is disabled, the phantom call remains active until the agent closes the work item.

---

## Licensing for Media Director

For information about licensing for Media Director, see [Types of license keys](#) on page 34.

---

## Checklist for configuring Media Director

The following checklist outlines the series of steps you must take to implement and administer Avaya Aura® Call Center Elite Multichannel Media Director.

Step	Task	✓
1	Install Application Management Service and start Application Management Director through Windows Services	
2	Install Media Director	
3	Start Call Center Elite Multichannel Control Panel If you do not see the Media Director service as already running, start the Media Director service through Windows Services.	
4	Configure and maintain Media Director using Call Center Elite Multichannel Control Panel	

---

## Switch settings sample

The following set of parameters represents an example of a queue in the `ASMediaDirector.ini` configuration file.

**[Queue 1]**

Queue ID = Queue\_1

VDN = 3512

Phantom Station DN List = 9165,9166,9167,9168,9169

Maximum Queued Work Items = 5

**Phantom stations**

When Queue\_1 in the Media Director receives a Media Store work item, the Queue\_1 asks the switch to generate a phantom call from one of five stations. For example, 9165. The Queue\_1 also queues the call to VDN 3512.

```

cancel  refresh  enter  clear  help  go to page  next page  prev page
display station 9165
STATION
Extension: 9165                Lock Messages? n          BCC: 0
Type: cti                     Security Code:            TN: 1
Port: X                       Coverage Path 1:         COR: 8
Name: Media Email Station 9165 Coverage Path 2:         COS: 1
                               Hunt-to Station:        Tests? y

STATION OPTIONS
      Loss Group: 1           Message Waiting Indicator: none
Off Premises Station? n
Command aborted

```

**VDN 3512**

VDN 3512 sends the call to vector 233 for processing. You can specify an announcement as the "VDN of Origin Annc. Extension" to announce: "This is a non-voice job".

```

cancel  refresh  enter  clear  help  go to page  next page  prev page
display vdn 3512                                     Page 1 of 2
VECTOR DIRECTORY NUMBER
Extension: 3512
Name: Multimedia Email 3512
Vector Number: 233
Attendant Vectoring? n
Allow UDN Override? n
COR: 1
TN: 1
Measured: both
Acceptable Service Level (sec): 20
UDN of Origin Annc. Extension:
1st Skill:
2nd Skill:
3rd Skill:
    
```

## Vector 233

Vector 233 queues the call to skill 67.

```

cancel  refresh  enter  clear  help  go to page  next page  prev page
display vector 233                                   Page 1 of 3
CALL VECTOR
Number: 233      Name: Media Email 233
Multimedia? n   Attendant Vectoring? n   Lock? n
Basic? y        EAS? y   G3U4 Enhanced? y   ANI/II-Digits? y   ASAI Routing? y
Prompting? y    LAI? y   G3U4 Adv Route? y   CINFO? y   BSR? y   Holidays? y
01 queue-to    skill 67  pri m
02 stop
03
04
05
06
07
08
09
10
11
    
```

## Skill 67

All agents who want to receive work items queued to Queue\_1 must log in to skill 67.



```

cancel  refresh  enter  clear  help  go to page  next page  prev page
display hunt-group 67                                     Page 1 of 3
HUNT GROUP
Group Number: 67                                         ACD? y
Group Name: Media Email Hunt 67                         Queue? y
Group Extension: 9876                                    Vector? y
Group Type: ead-mia
TN: 1
COR: 5                                                   MM Early Answer? n
Security Code:
ISDN Caller Display:

Queue Length: 15
Calls Warning Threshold:      Port:
Time Warning Threshold:      Port:

```

```

cancel  refresh  enter  clear  help  go to page  next page  prev page
display hunt-group 67                                     Page 2 of 3
HUNT GROUP
Skill? y          Expected Call Handling Time (sec): 180
AAS? n           Acceptable Service Level (sec): 180
Measured: both   Service Objective (sec): 20
Supervisor Extension: Service Level Supervisor? n

Controlling Adjunct: none

UuStats Objective:
Timed ACW Interval (sec):
Multiple Call Handling: none

Redirect on No Answer (rings): 5
Redirect to VDN: 3512
Forced Entry of Stroke Counts or Call Work Codes? n

```

## Setting up Telephony Server

### About this task

After you administer VDNs and phantom stations in the switch, you can set up a Telephony Server.

### Procedure

Set up the VDNs in the Telephony Services security database, if the security database is enabled.

## Setting up Application Enablement Services

### About this task

Using this procedure, you can set up Application Enablement Services.

### Procedure

1. Access your security database through your Web-based link.
2. Set up users and devices such as phantom stations and VDNs.

For more information, see *Avaya Aura® Application Enablement Services Administration and Maintenance Guide* available on <http://support.avaya.com>.

---

## Virtual Agent

Virtual Agent is a service in Avaya Aura® Call Center Elite Multichannel using which you can process work items through virtual agents instead of real agents. Virtual Agent lets you send emails or text messages to customers through a group of virtual agents, essentially creating an automated messaging service.

When a customer calls a phone number answered by Avaya Experience Portal, Virtual Agent provides access to data stored in Call Center Elite Multichannel to the customer. Virtual agents access the voice work items that are generated when these incoming phone calls are received. This process does not require manual effort except some initial set up by an administrator.

Virtual agents log in to Call Center Elite Multichannel XML Server, consume a station DN and an agent ID, and wait to receive and deliver Call Center Elite Multichannel work items.

The Virtual Agent service supports up to 300 concurrent virtual agents. Each virtual agent can receive one work item every second. The service starts automatically with the server operating system and configures through Call Center Elite Multichannel Control Panel.

---

## Worker plug-ins

To carry out tasks, Virtual Agent relies on certain plug-ins that are called as worker plug-ins.

The current release of Virtual Agent comes with two worker plug-ins:

- Web Service Worker plug-in: When a customer calls a phone number answered by Avaya Experience Portal, the plug-in provides access to data stored in Call Center Elite Multichannel to the customer.
- Outbound Worker plug-in: This plug-in lets you automatically send emails or text messages to customers.

## Database access to calling customers

Using the Web Service Worker plug-in, the calling customer can access the database. When the customer calls a phone number answered by Avaya Experience Portal, the customer can access the data stored in Call Center Elite Multichannel with the help of the plug-in.

Web Service Worker plug-in installs automatically as part of the Virtual Agent installation. To forward requests from the Avaya Experience Portal script to the Web Service Worker plug-in, you must install the Virtual Agent Web Service.

## Setting up Web Service Worker plug-in manually

### About this task

The call center administrator can manually set up the Web Service Worker plug-in.

### Procedure

1. Install Virtual Agent and Virtual Agent Web Service.
2. Configure Virtual Agent including the Web Service Worker plug-in through the Call Center Elite Multichannel Control Panel.
3. Use Orchestration Designer to load Virtual Agent Web Service methods into Avaya Experience Portal scripts. Use the file `VirtualAgentWebService.wsdl`

#### **Note:**

For more information about how to configure the Virtual Agent service, see [Configuring Virtual Agent](#) on page 54.

## Using Web Service Worker plug-in

### About this task

After you configure the plug-in, you can use the plug-in through the Web Service for Experience Portal.

### Procedure

To access the service, open the URL <http://localhost/VirtualAgentWebService/Service.asmx> from the local computer where the Web Service for Experience Portal is installed.

### Related Links

[Initialize](#) on page 64

## Outbound Worker plug-in automated process

Virtual Agent uses the Outbound Worker plug-in to automatically send bulk emails or text messages to customers.

Preview Contact Media Store creates work item at scheduled time and sends the work item to Media Director. Media Director then uses a phantom call to deliver the work item to a virtual agent. The virtual agent forwards work item to the Outbound Worker plug-in for processing

**\* Note:**

Outbound Worker plug-in only accepts work items according to the types and virtual agent groups specified in the configuration.

Outbound Worker plug-in creates a new work item on the specified Media Store using the data that comes from the contact record loaded in Call Center Elite Multichannel Control Panel. The Media Store then sends out the email or simple message to the customer.

## Setting up Outbound Worker plug-in manually

### About this task

Virtual Agent uses the Outbound Worker plug-in to automatically send bulk emails or text messages to customers. However, before the automated process begins, you must setup the Outbound Worker plug-in manually through the Call Center Elite Multichannel Control Panel.

### Procedure

1. Install Virtual Agent and configure the Virtual Agent service and the Outbound Worker plug-in through Call Center Elite Multichannel Control Panel.
2. Create the outbound program for Email Media Store or Simple Messaging Media Store.
3. Add queue to the Email or Simple Messaging Media Store and specify the ID of the outbound program.
4. Create outbound program for the Preview Contact Media Store that distributes data carrying work items to the Media Store.
5. Create schedule for sending out these work items and attach the schedule to outbound program.
6. Load contacts against the outbound program specifying method of contact. For example, email address or mobile number. This action also specifies the type of Media Store that sends out the message.

**\* Note:**

You can use the load contacts form to send out two types of messages to the same contact.

7. Configure the Preview Contact Media Store that carries customer data and the outgoing message to Media Director.
8. Configure Email Media Store or Simple Messaging Media Store that sends out the actual email or text message to the customer.

**\* Note:**

After the manual configuration is complete, the automated process runs at the scheduled time.

## Using Outbound Worker plug-in

### About this task

After you set up and configure the plug-in, you must load the work items to the Preview Contact Media Store outbound program.

### Procedure

1. Start Call Center Elite Multichannel Control Panel.
2. In the left pane, expand the **Preview Contact Media Stores** node.
3. Expand the **Preview Contact Media Store** node.
4. Right-click the program node and click **Load New Interactions**.

The system displays the **Load Interaction** tab in the right pane.

5. Click **Browse** and select a CSV file.

The screenshot shows a 'Customer Details' form with the following fields and values:

- Customer ID: The Customer's ID
- Name: The Customer's Name
- Address: The Customer's Address
- First contact: customer@email.com; First contact option: Email
- Second contact: customer sms number; Second contact option: Simple Messaging
- Third contact: (empty); Third contact option: (empty)
- Email outbound message: Dear Mr Customer...
- Simple Messaging outbound message: Dear Mr Customer..]
- Voice outbound message: (empty)

6. For the CSV file for Outbound Email, verify the following information:
  - The **First contact option**, **Second contact option**, or **Third contact option** field is set to Email.
  - The **Email outbound message** field contains the Email message content.
7. For the CSV file for Outbound SMS, verify the following information:
  - The **First contact option**, **Second contact option**, or **Third contact option** field is set to Simple Messaging.
  - The **Simple Messaging outbound message** field contains the SMS message content.

#### \* Note:

By default, a sample reference for the CSV file schema installs in the Call Center Elite Multichannel Control Panel folder:

```
\Avaya Aura CC Elite Multichannel\Desktop\CC Elite Multichannel Control Panel
\PreviewContactSchema.csv
```

## Configuring Virtual Agent

### About this task

You can configure Virtual Agents and specify the station numbers that Virtual Agents can monitor. Each station works as a virtual agent that receives incoming calls or work items and passes the calls or work items to a particular worker plug-in for processing.

To filter work items that a worker plug-in can accept, you can create virtual agent groups and specify the groups in the configuration of worker plug-in. After adding virtual agent groups, the worker plug-in accepts work items only from the agents belonging to the configured virtual agent groups. You can also filter work items for a worker plug-in by specifying the accepted work item types in the configuration of worker plug-in. A Virtual Agent can monitor up to 300 stations.

### Procedure

1. Start Call Center Elite Multichannel Control Panel.
2. In the left pane, expand the **Virtual Agents** node.
3. Right-click the **Virtual Agent** node and click **Edit**.
4. On the **Edit Virtual Agent** tab, enter appropriate values in the fields.
5. Right-click anywhere on the **Edit Virtual Agent** tab and click **Save and Close**.

### Virtual Agent field descriptions

Name	Description
<b>Media Director section</b>	
<b>Media Director</b>	The Media Director server name.
<b>URL</b>	The URL that Email Media Store (EMS) uses to connect to the Media Director server.  The system forms this URL using the values that you specify in the <b>IP</b> , <b>Port</b> , <b>Channel type</b> , and <b>URL</b> fields.
<b>IP</b>	The IP address of Media Director.  The system automatically adds the IP address or host name of the Media Director server when you select a Media Director in the <b>Media Director</b> field.
<b>Port</b>	The port number to access the Media Director server.
<b>Channel type</b>	The .Net remoting channel that the multimedia applications in Call Center Elite Multichannel use to communicate with each other.

*Table continues...*

Name	Description
	Default: gtcp.
<b>URI</b>	Uniform Resource Identifier (URI) of the remote communication object factory on the Media Director server.  Default: RemoteFactory.rem.
<b>Error Logging</b>	In the <b>Error Logging</b> section, you can enter the field values as mentioned in <a href="#">Error Logging</a> on page 339.
<b>Enable connection to License Director</b>	The check box to enable the connection to the License Director and the fields in the License Director section
<b>License Director section</b>	
<b>Primary IP</b>	The IP address of the primary License Director server.
<b>Primary port</b>	The port number to access the primary License Director server.
<b>Secondary IP</b>	The IP address of the secondary License Director server.
<b>Secondary port</b>	The port number to access the secondary License Director server.
 <b>Note:</b> The Outbound Worker plug-in requires additional VALUE_CCM_VOICE and VALUE_CCM_MULTICHANNEL license keys for each virtual agent. For more information, see <a href="#">License Director</a> on page 34.	
<b>Voice Media Stores section</b>	
<b>Available media stores on Media Directors</b>	You can displays media stores that you have configured and are available.
<b>Media store list</b>	The media stores to receive voice work items when the Virtual Agent does not connect to Media Director.

## Configuring XML Server for Virtual Agent Procedure

1. Start Call Center Elite Multichannel Control Panel.
2. In the left pane, expand the **Virtual Agents** node.
3. Expand the **Virtual Agent** node.
4. Right-click the **XML Server** node and click **Edit**.

**\* Note:**

Virtual Agent uses XML Server to monitor voice stations. If a Virtual Agent uses multiple XML Servers, the Virtual Agent can create another section with the same configuration entries by editing the `.ini` file. However, the section name must begin with XML Server. For example, `[XML Server AnotherServer]`.

5. On the **Edit XML Server** tab, enter appropriate values in the fields.
6. Right-click anywhere on the **Edit Virtual Agent** tab and click **Save and Close**.

**Related Links**

[Virtual Agent Edit XML Server field descriptions](#) on page 56

**Virtual Agent Edit XML Server field descriptions**

Name	Description
<b>Primary XML Server IP</b>	The primary IP address or computer name which is used by the Virtual Agent to connect to the primary server.
<b>Primary Link Name</b>	The TLink name, for example: AVAYA#AVAYA_ECS_PROD#CSTA#TSVROLD which is used by the Virtual Agent to connect to the primary XML Server. Once the Primary XML Server IP has been input, then click the <b>ellipses</b> (...) button to automatically retrieve the Primary Link Name.
<b>Primary XML Server Port</b>	The port number which is used by the Virtual Agent to connect to the Secondary XML Server.
<b>Secondary XML Server IP</b>	The primary IP address or computer name which is used by the Virtual Agent to connect to the Secondary server. If the Primary XML Server fails, the Virtual Agent will automatically connect to the Secondary XML Server to continue working.
<b>Secondary Link Name</b>	The TLink name, for example: AVAYA#AVAYA_ECS_PROD#CSTA#TSVROLD which is used by the Voice Media Store to connect to the Secondary XML Server. If the Primary XML Server fails, the Virtual Agent automatically connects to the Secondary XML Server to continue working.
<b>Secondary XML Server Port</b>	The port number which is used by the Virtual Agent to connect to the primary XML Server. If the primary XML Server fails, the Virtual Agent automatically connects to the secondary XML Server to continue working.



## Configuring a Virtual Agent group

### Procedure

1. Start Call Center Elite Multichannel Control Panel.
2. In the left pane, expand the **Virtual Agents** node.
3. Expand the **Virtual Agent** node.
4. Expand the **Virtual Agent Groups** node.
5. Right-click **Virtual Agent Group A** and click **Edit**.
6. On the **Edit Virtual Agent Group** tab, enter appropriate values in the fields.
7. Right-click anywhere on the **Edit Virtual Agent Group** tab and click **Save and Close**.

## Adding a Virtual Agent group

### Procedure

1. In the **Virtual Agents** node, expand the **Virtual Agent** node.
2. Right-click the **Virtual Agent Groups** node and select **Add Virtual Agent Group**.
3. Enter the appropriate values in fields on the **Add Virtual Agent Group** tab.  
For detailed field descriptions, see [Edit Virtual Agent Group field descriptions](#) on page 57.
4. Right-click anywhere on the **Add Virtual Agent Group** tab and select **Save and Close** to save the information.

## Edit Virtual Agent Group field descriptions

Name	Description
<b>Group name</b>	The name for an agent group.
<b>Enable virtual agent group</b>	The check box to enable the virtual agent group.
<b>Virtual Agent answers the call for voice work item</b>	<p>The check box to use Virtual Agent to answer incoming calls.</p> <p>Clear this check box if you want Communication Manager to answer an incoming call.</p> <p> <b>Note:</b></p> <p>For Communication Manager to answer incoming call, you must enable the <b>Auto Answer</b> feature.</p>
<b>Enable connection to Media Director</b>	The check box to use Virtual Agent to process multimedia work items.

*Table continues...*

Name	Description
	Clear this check box if you are using Virtual Agent only to process the voice work items.
<b>Connect to Media Director when agent logs in</b>	<p>The check box to connect Virtual Agent to Media Director when agents logs in to the switch.</p> <p>Clear this check box if you want to connect Virtual Agent to Media Director when Media Director starts.</p>
<b>Agent login mode</b>	<p>You can use the arrow to select the working mode for an agent.</p> <p>Agents are automatically placed in the selected working mode when they log in to Desktop. Agents can select from the Auxiliary, After Call Work, and Available working modes.</p> <p>For more information about work modes, see <i>Avaya Aura® Call Center Elite Multichannel Desktop User Guide</i>.</p>
<b>Agent available mode</b>	<p>You can use the arrow to select a mode for an agent when an agent ends a current call.</p> <p>Agents are automatically placed in the selected mode when they log in to the Desktop application. Agents can select from the Auto-In and Manual-In available modes.</p> <p>For more information, see <i>Avaya Aura® Call Center Elite Multichannel Desktop User Guide</i>.</p>
<b>Alarm Section</b>	
<b>Endpoint busy high water percentage(%)</b>	The high water point at which the system generates an alarm.
<b>Alarm on busy high water mark</b>	The check box to generate an alarm when the percentage of endpoints specified in the <b>End Point Busy High Water Percentage</b> field has reached.
<b>Alarm on all endpoints busy</b>	The check box to generate an alarm when all endpoints in a specific Virtual Agent group occupies with work.
<b>Agent List</b>	
<b>Station DN</b>	The station number of a Virtual Agent. Click the button next to this field to select stations DN's available in Communication Manager.
<b>Station password</b>	The password to access the specified station number.
<b>Agent ID</b>	The agent ID of a Virtual Agent. Click the button next to this field to select agents available in Communication Manager.

*Table continues...*

Name	Description
Agent password	The password for the specified agent ID.

---

## Configuring Virtual Agent Workers

### Procedure

1. Start Call Center Elite Multichannel Control Panel.
2. In the left pane, expand the **Virtual Agents** node.
3. Expand the **Workers** node.
4. Right-click the **Outbound Worker** node and click **Edit**.
5. On the **Edit Outbound Worker** tab, perform the following steps:
  - a. In the **Supported Call Center Elite Multichannel work item types** field, select the Call Center Elite Multichannel work items type that you want to be processed by the Outbound Worker.
  - b. In the **Supported customized work item type** field, enter the name of a custom work item type that you have.
  - c. In the **Agent group names** field, select the Virtual Agent group or groups that you want to assign to the Outbound Worker.
6. Right-click anywhere on the **Edit Outbound Worker** tab and click **Save**.
7. In the left pane, right-click the **Web Service Worker** node and click **Edit**.
8. On the **Edit Web Service Worker** tab, perform the following steps:
  - a. In the **Supported Call Center Elite Multichannel work item types** field, select the Call Center Elite Multichannel work items type that you want to be processed by the Web Service Worker.
  - b. In the **Supported customized work item type** field, enter the name of a custom work item type that you have.
  - c. In the **Agent group names** field, select the Virtual Agent group or groups that you want to assign to the Web Service Worker.
9. Right-click anywhere on the **Edit Web Service Worker** tab and click **Save and Close**.

---

## Configuring Virtual Agent for Web service

### About this task

Using this procedure, you can configure virtual agent for web service.

### Procedure

1. Start Call Center Elite Multichannel Control Panel.

2. In the left pane, expand the **Virtual Agents** node.
3. Expand the **Virtual Agent** node.
4. Right-click the **Virtual Agent Groups** node and click **Add Virtual Agent Group**.
5. On the **Add Virtual Agent Group** tab, perform the following steps
  - a. Ensure that the **Enable connection to Media Director** check box is not selected.
  - b. In the **Agent List** section, add the Experience Portal device that you want to monitor.
6. Right-click anywhere on the **Add Virtual Agent Group** tab and click **Save and Close**.
7. Assign your group to the Web Service Worker as mentioned in [Configuring Virtual Agent Workers](#) on page 59.
8. In the left pane, expand the **Virtual Media Stores** node.
9. Expand the **Virtual Media Store** node.
10. Expand the **XML Servers** node.
11. Right click the **XML Server** node and click **Edit**.
12. On the **Edit XML Server** tab, add the same Experience Portal device to the **Station list** section.
13. Right-click anywhere on the **Edit XML Server** tab and click **Save and Close**.
14. Click the **Voice Station** node to verify that the device is being monitored successfully.

---

## Customized programs for Outbound work items

To ensure that the programs that you assign to the Outbound work items are functional and able to send outbound work items, you must customize each Preview Contact Media Store outbound program in Call Center Elite Multichannel Control Panel.

### Sending an Outbound Email Work item

#### About this task

To send an outbound Email work item:

#### Procedure

1. Select the Email Media Store Queue that you want to use to send an outbound email.

Note the Program ID displayed in the **Work items for Email [0:0]** label. This Program ID is the same ID that is displayed in the **Program ID** field of the matching Media Store program.
2. Add a new program or Edit an existing Preview Contact Media Store Program by right-clicking on the node and selecting from the drop-down menu.

3. In the **Edit Program** dialogue box, Click the **Customized Configuration** tab and specify the following fields:
  - **Key:** You MUST enter “Outbound Program ID” manually in this field.
  - **Value:** Enter the Program ID of the Email Media Store.
  - **Topic:** You MUST enter “Email” in this field.
4. After you enter the values, save your settings.

## Sending an Outbound SMS Work Item

### Procedure

1. Select the Short Message Remote Service that you want to assign to the Outbound SMS Work Item.
2. Scroll to the bottom of the Summary Window to reveal the Channels information.
3. Note the Simple Messaging Media Store Queue name.
4. Select the relevant Simple Messaging Queue node to obtain the specific Program ID that will be used for the Outbound SMS Work item.
5. Add or edit an existing Preview Contact Media Store program and click the **Customized Configuration** tab.

The screenshot shows the 'Edit Program' dialog for 'Outbound SMS'. The 'Customized Configuration' tab is selected, showing a table with the following data:

Key	Value	Topic
Outbound Program ID	6dcdf32c-8c02-46d8-bb49-73c38bfcf3ed	Simple Messaging
Service Name	Sales	Simple Messaging
*		

6. First enter:
  - **Key:** You must enter Outbound Program ID manually into this field.
  - **Value:** Enter the Program ID of the Simple Messaging Media Store.

- **Topic:** You must enter `Simple Messaging` into this field.
7. Then enter:
- **Key:** Service Name
  - **Value:** Enter the Short Message Service Gateway remote service name.
  - **Topic:** You must enter `Simple Messaging` into this field.
8. Save your settings.

---

## Integrating Experience Portal with Virtual Agent Web Service

### About this task

To integrate Experience Portal with Virtual Agent, you must use Avaya Orchestration Designer with the `VirtualAgentWebService.wsdl` file located in the `\Avaya Aura CC Elite Multichannel\Server\Virtual Agent Web Service` directory.

---

## Web Service Worker plug-in architecture

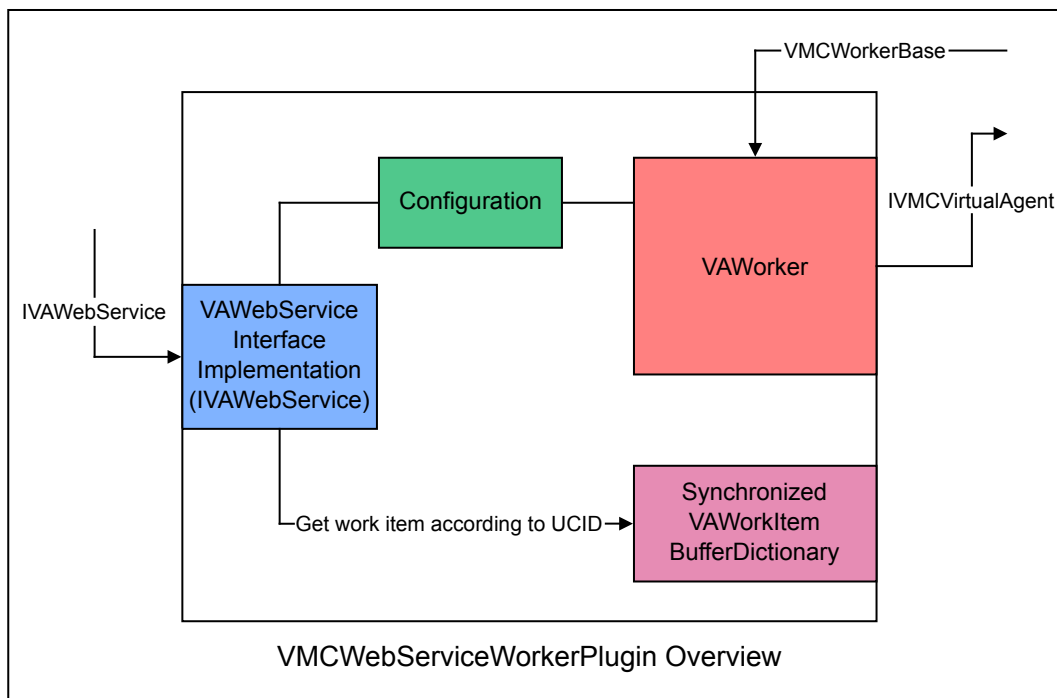

VASWebServiceWorkerPlugin is the worker plug-in for VA that is based on the Service Plug-in Host architecture.

VAWebServiceWorkerPlugin is the main plug-in class that on startup, instantiates the following classes:

- **VAWorker:** This class overrides the VMCWorkerBase abstract class. With this action, this VAWorker can receive work items from VMC and buffer these work items in a synchronized dictionary that uses UCID as the key.
- **VAWorkItemBufferDictionary:** This wrapper class contains two synchronized dictionary buffer. The first dictionary has the UCID or InteractionID as the key and the work item as the value. The second dictionary has the CallID or Identifier as the key and UCID or InteractionID as the value. VAWorkItemBufferDictionary is a single wrapper class and implements, based on the singleton pattern.
- **I VAWebServiceImplement:** This class implements the remoting interface with the VMCWebService and on initialization sets up a remote listening channel.
- **RequestBufferDictionary:** This wrapper class contains a single synchronized dictionary buffer. This dictionary has the UCID or InteractionID as a key and the ManualResetEvent object as the value. RequestBufferDictionary is a single wrapper class and implements based on the singleton pattern. The dictionary populates only when the “Get work item according to UCID” failed to retrieve the work item from the VAWorkItemBufferDictionary.
- **Configuration:** This class implements configuration loading for the worker plug-in.

The “Get work item according to UCID” in the figure, VAWebServiceWorkerPlugin Overview waits for a specified time if the UCID does not exist in the VAWorkItemBufferDictionary. This wait time can configure and become the “Work Item Wait Time Seconds” configuration item.

## VAWebServiceWorkerPlugin startup

The VAWebServiceWorkerPlugin starts when VA starts as a windows service and is based on the SPIH plug-in architecture.

While the VAWebService starts from IIS and listens for web service requests.

## VAWebServiceWorkerPlugin configuration

The following is a sample configuration that includes default values.

### [Plugin Assembly List]

Virtual Agent Web Service Worker Section = Virtual Agent Web Service Worker

### [Virtual Agent Web Service Worker]

Assembly File Name = ASVAWebServiceWorkerPlugin.dll

Plugin ID =

Supported Work Item Types = 0

Accepted Agent Groups =

Web Service Worker Plug-in Architecture

The Supported Work Item Types configuration has a default value of 0, which means all work item types are supported.

## IVASWebService interfaces

This interface is used for the remoting channel between VASWebService and the VASWebServiceWorkerPlugin. The VASWebServiceWorkerPlugin implements the interface and VASWebService makes method invocation through this interface via .net remoting.

There are two distinct return classes. Both of which are serialized. The two distinct return classes are VASReturnClass and WorkItemProp classes. WorkItemProp is exclusively for the GetWorkItemProperties method, while the VASReturnClass is the generalized return class for all other web methods. Within the Avaya Experience Portal, these two classes are setup as a Complex Variable.

The third return type is a string return and is used only by the TestConnectivity method.

---

## Web Service methods

### Initialize

Using the Initialize method, applications get full control when the work item closes and removes from the work item buffer within ASVASWebServiceWorkerPlugin.dll. This means that even when the media stores close, the work item remains available in the buffer until CloseWorkItem is called. If you do not use the Initialize method, the work item does not remain in the buffer.

- UCID: This parameter takes either the UCID of the voice call or the InteractionID of the work item for non-voice work item types. If the UCID is unavailable, the CloseWorkItem tries to retrieve the valid UCID/InteractionID in the CallID/Identifier dictionary.

#### Returns:

VASReturnClass

#### Syntax:

```
VASReturnClass Initialize(string UCID);
```

### CloseWorkItem

This method indicates that the work item related to the UCID or InteractionID can be closed now. If an Extra Data updates, the CloseWorkItem also calls the SetCustomerData method before closing the work item. The work item also removes from the work item buffers.

- UCID: This parameter takes either the UCID of the voice call or the InteractionID of the work item for non-voice work item types. If the UCID is unavailable, the CloseWorkItem tries to retrieve the valid UCID or InteractionID in the CallID or Identifier dictionary. This action specifies the UCID or InteractionID associated with the work item to close.

#### Returns:

VASReturnClass

#### Syntax:

```
VASReturnClass CloseWorkItem(string UCID);
```



## SuspendWorkItem

This method indicates that the work item related to the UCID/InteractionID can be suspended now.

- **UCID:** This parameter takes either the UCID of the voice call or the InteractionID of the work item for non-voice work item types. If the UCID is unavailable, the SuspendWorkItem tries to retrieve the valid UCID/InteractionID in the CallID/Identifier dictionary. This action specifies the UCID/InteractionID associated with the work item to suspend.
- **InvokeRef:** This parameter is a free text parameter that must be unique if you tie this request to a particular event. This parameter is currently reserved for future use and can be blank.
- **SuspendDuration:** This parameter takes the string format type [-]d.hh:mm:ss.ff, where d = number of days, hh = hours as measured on a 24 hour clock, mm = minutes, ss = seconds and ff = fractions of seconds. With the VAWebService, users can input the single components of Days, Hours, Minutes and Seconds only and the fractions are set to 0. The VAWebService converts the information to a TimeSpan format that is acceptable for this suspendDuration parameter.
- **SuspendReason:** This parameter specifies the reason for the work item being suspended.
- **PreferredAgentID:** This parameter specifies the agent that this work item must return if available. If the agent is unavailable, the work item reverts to the standard ACD to return to the next available agent.
- **PreferredAgentOnly:** This parameter ensures that the work item is returned to the specified preferredAgentID when set to `true`.

### Returns:

VAWSReturnClass

### Syntax:

```
VAWSReturnClass SuspendWorkItem(string UCID, string invokeRef,
System.TimeSpan suspendDuration, string suspendReason, string
preferredAgentID, bool preferredAgentOnly);
```

## GetExtraData

This method returns the value from the specified Key and Topic or both pair for the specified UCID/InteractionID of the work item. If no topic is defined, it returns all the values for the Key defined.

- **UCID:** This parameter takes either the UCID of the voice call or the InteractionID of the work item for non-voice work item types. If the UCID is unavailable, the GetExtraData tries to retrieve the valid UCID/InteractionID in the CallID/Identifier dictionary.
- **NextRecordSetIndex:** This parameter defines the zero based index that indicates the next data row to start retrieving values from. Enter 0 for the first GetExtraData method invocation for the UCID defined. Subsequent ones use the previously returned NextRecordSetIndex value from the VAWSReturnClass.
- **Key:** This parameter specifies the Key for the Extra Data from the Associated Data table that is to be retrieved.
- **Topic:** This parameter specifies the Topic for the Extra Data from the Associated Data table that is to be retrieved. This parameter is optional and can be blank.

**Returns:**

VAWSReturnClass

**Syntax:**

```
VAWSReturnClass GetExtraData(string UCID, int NextRecordSetIndex, string Key, string Topic);
```

## SetExtraData

This method updates the value of the specified Key and Topic or both pair available from the specified UCID or InteractionID. If the Key or Topic pair is unavailable, the pair is created. Both the Key and Topic values are required and cannot be blank.

- UCID: This parameter takes either the UCID of the voice call or the InteractionID of the work item for non-voice work item types. If the UCID is unavailable, SetExtraData tries to retrieve the valid UCID or InteractionID in the CallID or Identifier dictionary.
- Key: This parameter specifies the Key of the Extra Data from the Associated Data table that is to be updated or added.
- Topic: This parameter specifies the Topic of the Extra Data from the Associated Data table to be updated.
- Value: This parameter specifies the value to be set for the specified Key or Topic pair for the mentioned work item as provided by the UCID or InteractionID.

**Returns:**

VAWSReturnClass

**Syntax:**

```
VAWSReturnClass SetExtraData(string UCID, string Key, string Topic, string Value);
```

## DeleteExtraData

This method deletes the specified Key and Topic or both pair for the specified UCID or InteractionID. If no Topic is defined, all entries that match the Key will be deleted.

- UCID: This parameter takes either the UCID of the voice call or the InteractionID of the work item for non-voice work item types. If the UCID is unavailable, the DeleteExtradata tries to retrieve the valid UCID or InteractionID in the CallID or Identifier dictionary.
- Key: This parameter specifies the Key of the Extra Data from the Associated Data table to be deleted.
- Topic: This parameter specifies the particular Topic associated with the Key to be deleted. This parameter is optional and can be blank.

**Returns:**

VAWSReturnClass

**Syntax:**

```
VAWSReturnClass DeleteExtraData(string UCID, string Key, string Topic);
```

## GetQueueData

This method returns the value from the specified Key and Topic or both pair for the specified UCID or InteractionID of the work item. If no topic is defined, GetQueueData returns all values for the Key defined.

- UCID: This parameter takes either the UCID of the voice call or the InteractionID of the work item for non-voice work item types. If the UCID is unavailable, GetQueueData tries to retrieve the valid UCID/InteractionID in the CallID/Identifier dictionary.
- NextRecordSetIndex: This parameter defines the zero based index that indicates the next data row to start retrieving values from. Enter 0 for the first GetQueueData method invocation for the UCID defined. Subsequent ones use the previously returned NextRecordSetIndex value from the VAWSReturnClass.
- Key: This parameter specifies the Key for the Queue Data from the Queue Configuration table that is to be retrieved.
- Topic: This parameter specifies the Topic for the Queue Data from the Queue Configuration table that is to be retrieved. This parameter is optional and can be blank.

### Returns:

VAWSReturnClass

### Syntax:

```
VAWSReturnClass GetQueueData(string UCID, int NextRecordSetIndex, string Key, string Topic);
```

## GetWorkItemProperties

This method returns the entire work item data associated with the specified UCID or InteractionID in the WorkItemProp class.

- UCID: This parameter takes either the UCID of the voice call or the InteractionID of the work item for non-voice work item types. If the UCID is unavailable, the GetWorkItemProperties tries to retrieve the valid UCID or InteractionID in the CallID/Identifier dictionary.

### Returns:

WorkItemProp

### Syntax:

```
WorkItemProp GetWorkItemProperties(string UCID);
```

## TestConnectivity

Using this method, users can verify and pinpoint the connections. This action helps to check if the connection from the web method right through to the web method implementation in the worker plug-in is working correctly. The users can also verify the number of work items available in the two dictionary buffers by TestConnectivity. Both dictionary buffers must synchronize and therefore must contain the same number.

The string return indicates exception errors where a failure is encountered. If successful, the connectivity is working and will return the dictionary buffer counts.

**Returns:**

string

**Syntax:**

```
string TestConnectivity();
```

**Additional Parameters for GetExtraData and GetQueueData methods**

These methods have an extra parameter that needs to be specified. This is the zero based NextRecordSetIndex.

To retrieve all values for the Key specified for the first time, the GetExtraData or GetQueueData method has the NextRecordSetIndex set to 0. Subsequent calls to the GetExtraData or GetQueueData can use the VAWSReturnClass.NextRecordSetIndex as the parameter for the NextRecordSetIndex. With this action, the list of values can be daisy chained from the table providing 20 results at a time because the VAWSReturnClass contains ValueX that populates. In valueX, X is can be a number from 1 to 20.

The VAWSReturnClass.RecordCount value indicates the total number of records. With the VAWSReturnClassRecordCount, the application can determine the end of record. The VAWSReturnClass.NextRecordSetIndex also sets to the last record index. This record is one less than the RecordCount, that is, If RecordCount = 43, then at the end, it sets NextRecordSetIndex = 42).

**Returned Values**

Returned Values are of three sets: the WorkItemProp class, the VAWSReturnClass, and the string data type. The VAWSReturnClass is the general return type. The WorkItemProp and string data type are reserved only for the two methods, GetWorkItemProperties and TestConnectivity, respectively. The following are the parameters within the VAWSReturnClass and WorkItemProp constructor classes with default values:

[Serializable]

```
public VAWSReturnClass() {  
    ReturnCode = -1;  
    ReturnMessage = string.Empty;  
    RecordCount = 0;  
    NextRecordSetIndex = 0;  
    Value1 = string.Empty;  
    Value2 = string.Empty;  
    Value3 = string.Empty;  
    Value4 = string.Empty;  
    Value5 = string.Empty;  
    Value6 = string.Empty;  
}
```

```
Value7 = string.Empty;  
Value8 = string.Empty;  
Value9 = string.Empty;  
Value10 = string.Empty;  
Value11 = string.Empty;  
Value12 = string.Empty;  
Value13 = string.Empty;  
Value14 = string.Empty;  
Value15 = string.Empty;  
Value16 = string.Empty;  
Value17 = string.Empty;  
Value18 = string.Empty;  
Value19 = string.Empty;  
Value20 = string.Empty;  
}
```

**[Serializable]**

```
public WorkItemProp() {  
    ReturnCode = -1;  
    CreatedOn = String.Empty;  
    CustomerIdentifier = string.Empty;  
    Identifier = string.Empty;  
    Type = -1;  
    ConversationID = string.Empty;  
    InteractionID = string.Empty;  
    MediaStoreServerInstanceID = string.Empty;  
    ParentInteractionID = string.Empty;  
    AgentGroupName = string.Empty;  
    AgentID = string.Empty;  
    AgentIdentifier = string.Empty;  
    CallID = string.Empty;  
    Skill = string.Empty;  
}
```

```
StationDN = string.Empty;  
UCID = string.Empty;  
VDN = string.Empty;  
WorkItemType = string.Empty;  
}
```

 **Note:**

Currently, only GetWorkItemProperties method is available. However, the SetWorkItemProperties method can also be included on requirement.

---

## Media Gateways

Instant Messaging, texting and web chatting are principle mechanisms for communication in both the business-to-business and customer-to-business environments.

Avaya Aura® Call Center Elite Multichannel now broadens the customer service capability of your contact center by allowing you to blend with the following Gateways with inbound telephone calls.

- **AOL or ICQ Instant Messenger messages:** Customers or business associates who enjoy using the internet can make contact with you via AOL or ICQ Instant Messenger and receive the same treatment as telephone callers.
- **Communicator Gateway:** Enables communication with any number of Office Communicator clients.
- **MSN Messenger Gateway:** Customers or business associates who enjoy using the internet can make contact with you via MSN Messenger and receive the same treatment as telephone callers
- **Short Message Service Gateway :** Customers or business associates who like the convenience of mobile texting can make contact with you and receive the same treatment as telephone callers
- **XMPP Gateway:** The XMPP Gateway is a server application that provides conversion from XMPP (Extended Messaging and Presence Protocol) to Avaya Aura® Call Center Elite Multichannel Simple Messaging Media Store. XMPP supported features:
  - Instant messages
  - Call Center Elite Multichannel Presence in XMPP Customer client
  - Outbound sessions
  - Outbound session - checks actual presence of the contact
- **Web Chat Gateway:** Customers or business associates who enjoy using the internet can browse your company website, click a link to initiate a web-based conversation with a call center agent and receive the same treatment as telephone callers.

By using your existing computer telephony environment, they can enjoy the benefits of priority queuing and distribution to agents with relevant skills and knowledge.

What's more, customers do not need to install additional client software on their PC. All they need is one of the above messenger and the login details you provide them.

Messenger Gateway works alongside the Simple Messaging Media Store, Media Director and Call Center Elite Multichannel Desktop as part of a multimedia suite.

Simple Messaging Media Store is one of three media stores that deliver a range of non-voice work items to contact center agents. For more information, see [The Multimedia environment](#) on page 71. Providing base messaging functionality for the Messenger Gateways, Simple Messaging Media Store performs the following functions:

- Gives queuing priority to messages received from special customers.
- Rejects messages from certain customers and automatically email them that this has happened.
- Only allows messages from certain customers to queue to certain Media Director queues.

Messenger Gateway sits between the remote server and Simple Messaging Media Store:

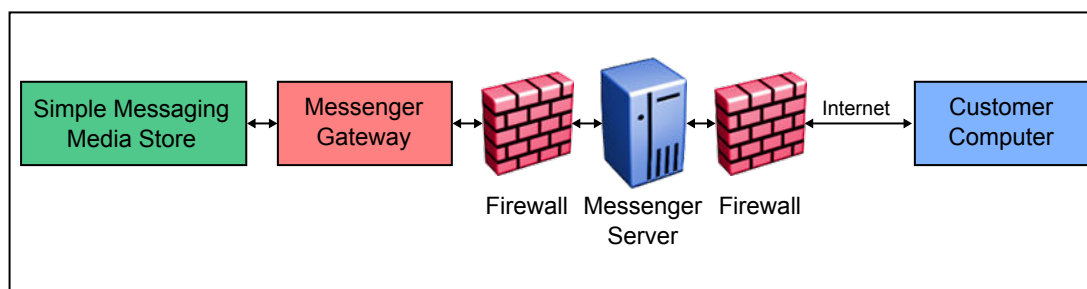

---

## The Multimedia environment

For details, see [Media Stores overview](#) on page 73.

### Related Links

[Adding licenses to WebLM Server](#) on page 38

---

## Messenger Gateways configuration overview

To configure Messenger Gateways, you must list the service areas of your business. Each service has an account name and a Simple Messaging Media Store queue to help the flow of conversation requests.

In the example outlined in the following diagram, a customer signs into Messenger Gateway, adds a company account name to the contact list, and initiates a conversation with the company.

After the customer initiates a conversation, Messenger Gateway matches the account name with a remote service queue in the configuration and forwards the conversation request to the Simple Messaging Media Store queue assigned to the service. Simple Messaging Media Store forwards the conversation request to the Media Director queue configured for that queue.

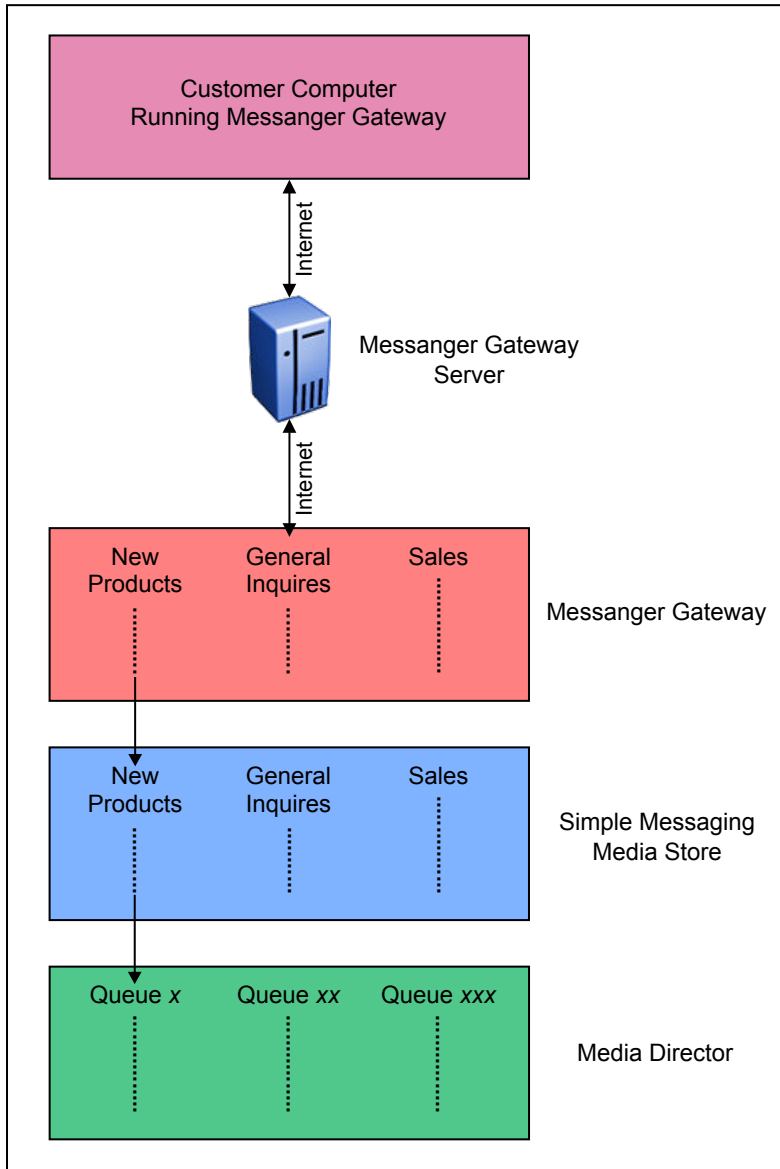



---

# Media Stores

---

## Media Stores overview

When a media store receives a new work item from a media source the media store creates a work item object and passes a reference for that object to Media Director. The media store receives the new work item in the form of: email server for the Email Media Store, web server for the Simple Messaging Media Store, or SQL database for the Preview Contact Media Store.

The reference tells Media Director what queue ID the work item must associate with and what priority it must have in the queue. Using the information in the configuration that relates specifically to the queue, the Media Director asks the Avaya Communication Manager through XML server to generate a phantom call for the object and route it to the appropriate skill.

Because the Media Director is written entirely in the .Net environment, the connection to the Telephony Server uses the XML Server and the .Net assemblies.

When an agent logged into the split/skill becomes available, the Avaya Communication Manager delivers the most appropriate phantom call to that agent. Media Director via the Telephony Server is monitoring the VDN and sees the phantom call delivered to the agent. Media Director transfers the work item reference with the oldest, highest-priority object to Media Proxy at the agent desktop. Objects rank according to a priority scale with 1 being the highest without lower limit and 5 is the default. For example, if Media Director has an object with priority 1 queued for 1 minute and an object with priority 2 queued for 10 minutes, the priority 1 object gets the agent. Objects that have the same priority ranks as first-in, first-out.

If the Media Director queue has the preferred agent functionality enabled, work item objects with a preferred agent ID assigned to Media Director delivers to the agent under certain circumstances. If a work item object specifies a preferred agent is in the queue of highest priority work items, Media Director transfers the work item to the available agent. Media Director transfers the work item of highest priority in spite of the other work items been waiting longer. If the preferred agent is unavailable, the object is delivered in the order the work item object was received to the next available agent.

Media Proxy delivers the reference to the correct Call Center Elite Multichannel Desktop application based on the specified work item type. Call Center Elite Multichannel Desktop uses the reference to retrieve the data directly from the work item at the media store.

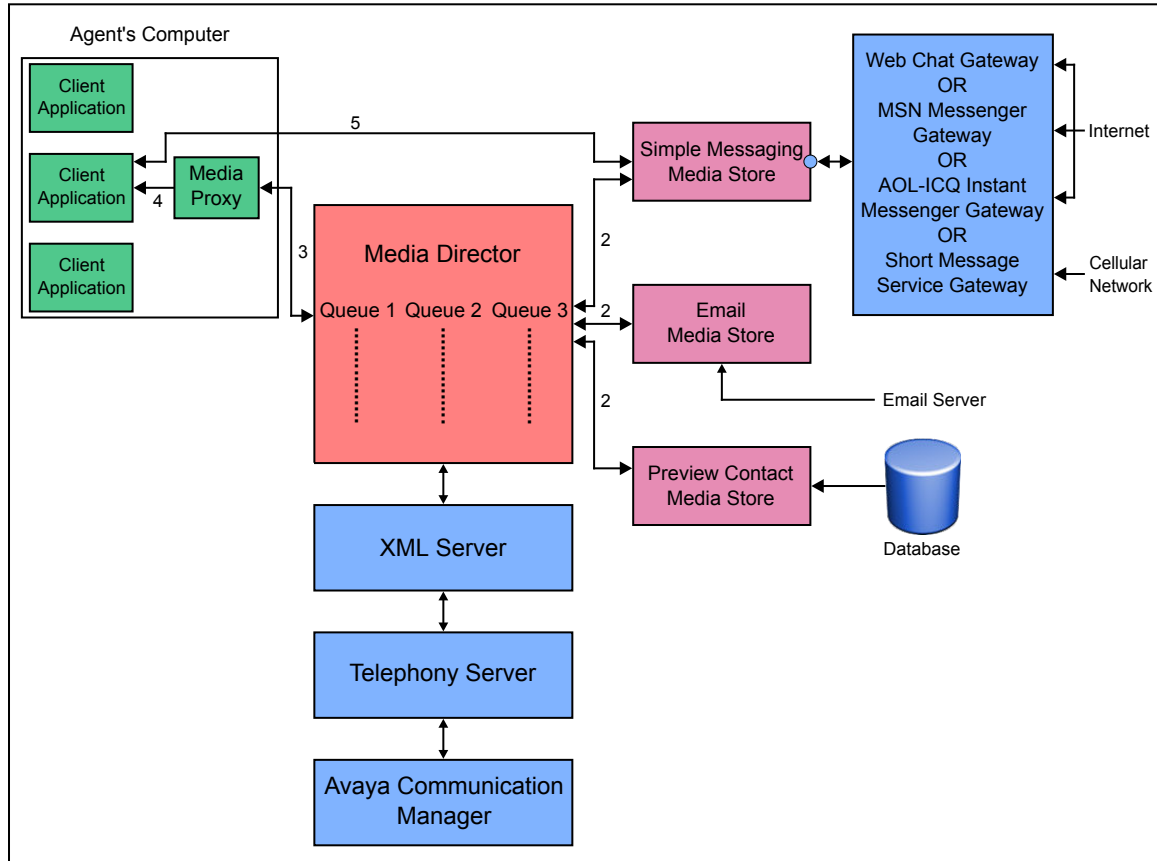

## Checklist for implementing and administering Media Stores

The following checklist outlines the steps that you must be perform to implement and administer Call Center Elite Multichannel Media Stores.

Step	Task	✓
1	Install Application Management Service and start Application Management Director through Windows Services	
2	Install Media Store	
3	Create ASMSControl database Do not create the ASMSControl database if the ASMSControl database already exists	
4	Start Call Center Elite Multichannel Control Panel If Media Store services are not already running, start the service through Windows Services.	

*Table continues...*

Step	Task	✓
5	Configure and maintain Media Store using Call Center Elite Multichannel Control Panel.	

## Email Media Store

The Email Media Store is one of the media stores that interact with the Media Director, Media Proxy, and Call Center Elite Multichannel Desktop to deliver non-voice work items to contact center agents.

Running as a service, the Email Media Store allows you to blend customer email inquiries with inbound telephone calls, essentially using this work to fill in the gaps between peaks in call traffic.

Email Media Store receives emails from one or more mail servers using the POP3 protocol.

Email Media Store is installed on a system that runs on Microsoft Windows 2008 R2 SP1 Server such as, Enterprise and Standard 64-bit or Microsoft Windows 2008 SP2 Server such as, Enterprise and Standard 32-bit or 64-bit. Email Media Store uses the configuration data and the information specified in the database schema to:

- Distribute emails sent to certain mailboxes to certain queues in the Media Director.
- Manage that distribution by making email queues “open” for certain times and days of the week.
- Give queuing priority to emails received from special customers.
- Assign different queuing priorities to the first email a customer sends and all subsequent emails sent as part of the same conversation.
- Reject emails from certain customers and automatically email the customer that the email is rejected.
- Emails can be queued only from certain customers to a certain email queue.
- Automatically informs a customer by email that the email was received during or outside the operating hours of that queue.
- Accepts incoming Digitally Signed Emails. The digitally signed email shows as an attachment with the name “smime.p7s”. CCEM does not verify the signature.

## Email Media Store startup

The Email Media Store is a service that starts with the operating system. After loading configuration data via the Configuration Client, the Email Media Store starts logging errors and connects to the Media Director via the .Net Remoting framework. After this connection establishes, the Email Media Store starts polling the various email servers to retrieve inbound emails for processing.

## Emails retrieval

For each interval that the Mailbox Check Interval parameter in the configuration governs, Email Media Store connects to the specified Email Server and downloads new emails. The email downloaded from one mailbox matches to one email queue in Email Media Store. Each email queue is configured to send email to a Media Director queue with certain priority.

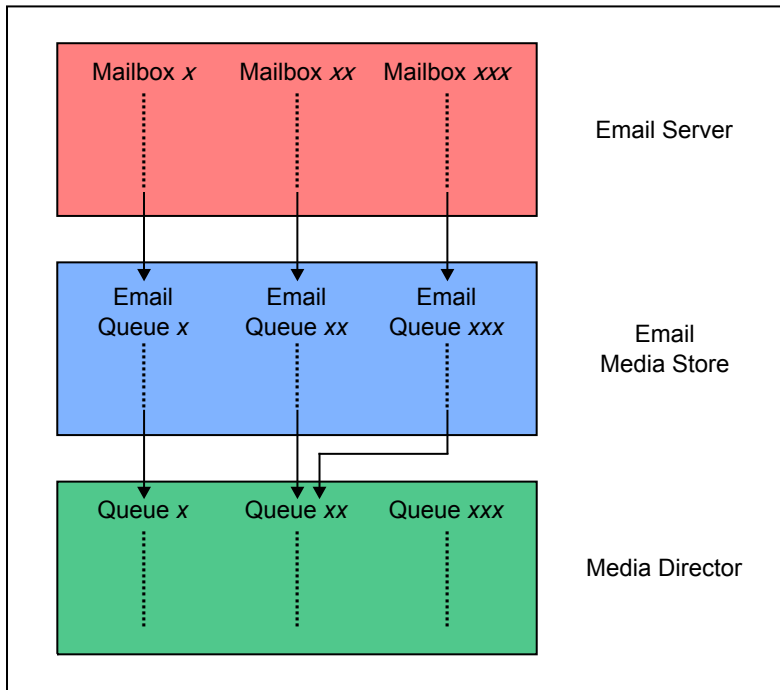

After the email is downloaded, the email is deleted from Email Server and the connection between Email Media Store and Email Server is closed. In addition, Email Media Store goes through the following processing steps:

1. Checks for automated responses or error messages.

With a quick scan of the Subject field, certain types of emails are filtered before the emails are queued as normal work items.

- **Out of office reply:** Standard out-of-office replies that are automatically sent by many email systems are discarded.
- **Error in sending:** Error messages that are automatically sent when the destination is unreachable or unknown are logged against a conversation if possible and forwarded to an administrator for action.

2. Checks for denied and allowed senders.

The Email Media Store database schema contains a list of email addresses that are blocked from sending email to the queue. Should an email be received from one of these addresses where the email is marked as invalid and blocked. Moreover, if the Notify parameter is enabled against the sender name, an email response is automatically sent informing the sender that the email is rejected.

The media store also contains a list of senders who can email certain queues. An email queue that only accepts emails from certain groups is called as closed sender group. If a sender email is not in the list, the email is marked as invalid and the appropriate response is automatically sent to the sender.

3. Interrogates the mail headers.

The Email Media Store checks the Subject field to search the conversation ID. If the conversation ID is absent, Media Store automatically sends an email informing the customer that the customer is in queue and when to expect an agent response. Media Store sends the email if the customer makes contact within the operating hours. If the header is present, the email is associated with the existing conversation.

4. Checks for priority customer status.

Email Media Store decides emails received from certain sender addresses or domains to have queuing priority. If a sender address matches an entry in the PriorityContacts Table, the priority of the queued work item is extracted from this table. If no match is available, the priority is the default for the email queue that is the mailbox, as set in the configuration data.

## Email storage

Because of the huge variety in the size and format, emails are stored to the file system as individual files with a file name as GUID.

## Adding a template in Email Media Store

### Procedure

1. Start Call Center Elite Multichannel Control Panel.
2. In the left pane, expand the **Email Media Stores** node.
3. Expand the **Email Media Store** node.
4. Right-click the **Templates** node and click **Manage Templates**.
5. On the **Manage Templates** tab, right-click a group and click **Add Child Template**.
6. In the **Name** field, enter a name for the template.
7. In the **Description** field, enter a description for the template.
8. In the **Character set** field, click the appropriate character set.
9. Click **OK**.

The system adds the template in the group.

10. Click the template to view the **Subject** and **Attachment** fields and the message text box.

### \* Note:

In the message text box, you cannot perform the cut, copy, and paste operations through the respective buttons on the HTML editor.

## Setting the Resident Expert Response pre-processor

### About this task

Using this procedure, you can set the Resident Expert Response pre-processor.

**Procedure**

1. Start Call Center Elite Multichannel Control Panel.
2. In the left pane, expand the **Email Media Stores** node.
3. Expand the **Email Media Store** node.
4. Right-click the **Queues** node and click **Add Queue**.
5. On the **Add Queue** tab, click the **Components** tab.
6. In the **Preprocessing Components** section, click **Resident Expert Response pre-processor**.
7. In the **Resident Expert [RE]** section, enter appropriate values in the fields.

**Related Links**

[Resident Expert response pre-processor field descriptions](#) on page 78

**Resident Expert response pre-processor field descriptions**

Name	Description
<b>RE list</b>	A comma-separated list of email addresses belonging to the resident experts for this queue.
<b>Instructions file name direct to customer</b>	A file to be attached to an email forwarded to a resident expert, when the resident expert has to reply directly to the customer. EMS automatically searches for the file in EMS installation folder. To change the location, specify the full file path with the file name.
<b>Instructions file name return to agent</b>	The file to be attached to emails forwarded to a resident expert when the expert is expected to reply to the agent. EMS automatically searches for the file in EMS own installation folder. If you want to change the location, specify the full file path with the file name.
<b>RE footer content file</b>	The name of the text file that contains the body of the footer that is included in every message forwarded to the resident expert.
<b>RE footer character set</b>	The character set with which the footer text is encoded. The default is the default encoding of the server.
<b>RE subject prefix</b>	The text that prefix the subject of messages forwarded to the resident expert. The default is "Forward To RE."
<b>RE reply to customer by default</b>	This check box when selected, automatically selects the Reply Directly To Customer check box in an email work item that is forwarded to a resident expert.

*Table continues...*

Name	Description
	If you clear this check box, the system sends the reply from a resident expert to the Media Director to redistribute that email to the next available agent.
<b>RE deliberation interval</b>	The length of time, in minutes, an email waits in an inbox of the resident expert, without being replied to, before it is sent back to Media Director for redistribution to the next available agent. The default is 60. If set to 0, the email never returns to the agent queue.

## Setting the Keyword Based Routing pre-processor

### About this task

Using this procedure, you can set the Keyword Based Routing pre-processor.

### Procedure



1. Start Call Center Elite Multichannel Control Panel.
2. In the left pane, expand the **Email Media Stores** node.
3. Expand the **Email Media Store** node.
4. Right-click the **Queues** node and click **Add Queue**.
5. On the **Add Queue** tab, click the **Components** tab.
6. In the **Preprocessing Components** section, click **Keyword Based Routing pre-processor**.
7. In the **Rule Assignment** and **Rule Details** sections, enter appropriate values in the fields.

For detailed field descriptions, see [Keyword Based Routing pre-processor field descriptions](#) on page 79.

### Keyword Based Routing pre-processor field descriptions

Name	Description
<b>For Rule</b>	You can use this field to select a rule that you want to assign to this queue.
<b>Route to</b>	You can select <b>Queue</b> or <b>Preferred Agent</b> to route an email work item to either a queue or to a preferred agent.
<b>Queue</b>	This field displays when you select the Queue option in <b>Route to</b> field.  Using this option you can select a queue to which you want to route the email work item. The <b>Queue</b> field does not display the name of the queue that you are currently editing.

*Table continues...*

Name	Description
<b>Preferred Agent</b>	<p>This field displays when you select the Preferred Agent option in <b>Route to</b> field.</p> <p>Enter the agent ID of the preferred agent to whom you want to route an email work item. Preferred Agent functionality is best efforts routing, and depends on the routing algorithm of Communication Manager.</p>
<b>Add</b>	<p>You can use this button to add a rule to this queue.</p> <p> <b>Important:</b> You must select a rule in the <b>For Rule</b> field to enable this button.</p> <p>After you add a rule, the system removes that rule from the <b>For Rule</b> field.</p>
<b>Update</b>	<p>You can use this button to modify a rule that you have added.</p> <p> <b>Important:</b> You must select a rule in the <b>Rule List</b> field to enable this button.</p> <p>The system displays the updated rule in the <b>Rule List</b> field and disables the <b>Update</b> button.</p>
<b>Remove</b>	<p>You can use this button to remove a rule.</p> <p> <b>Important:</b> You must select a rule in the <b>Rule List</b> field to enable this button.</p> <p>After you remove a rule from the <b>Rule List</b> field, the system adds that rule in the <b>For Rule</b> field. The system removes the selected rule from the <b>Rule List</b> field and disables the <b>Remove</b> button.</p>
<b>Rule List</b>	<p>A list that display rules assigned to a queue.</p> <p>You can use the <b>MoveUP</b> or <b>MoveDown</b> button to change the sequence in which the EMS executes the rules from the <b>Rule List</b> field.</p> <p>By default, EMS evaluates the rules from top to bottom. When EMS finds a rule that matches the specified condition, it stops matching further rules in the rule list.</p>
<b>Rule Details</b>	<p>A section that displays the information about the keywords that you have included and excluded in a rule, and the fields in an email that the system checks for matching the rule.</p>



## Keyword based email routing

You can use keyword based email routing to route an incoming email work item to an appropriate queue or a preferred agent, based on the configured keywords or a combination of keywords.

In Email Media Store, you can create a rule by specifying keywords or a combination of keywords and assign that rule to an email queue. When an email work item comes from a customer, Email Media Store analyzes the contents in the email subject, email body, or both based on a rule that you have assigned to an email queue in which the email work item has arrived.

While analyzing the contents of an email, Email Media Store compares a word with the keywords specified in a rule. Email Media Store ignores the punctuation marks in a word. For example, if an email body contains a word “XYZbank” in double quotes, and if a rule has a keyword XYZbank without punctuation mark, EMS matches the word with the keyword by ignoring the punctuation marks.

EMS differentiates a word by analyzing the space before and after a word. For example, EMS considers **XYZ bank** in an email as two separate words and compares both the words separately with the keywords.

In Control Panel, you can add a rule in the **Email Media Store** node, and specify the keywords in the system to search in an email subject, an email body, or both. In the **Email Media Store** node, you can also assign a rule to queue. For more information, see [Adding a queue for Email Media Store](#) on page 136.

### Adding a rule

#### About this task

Using the following procedure, you can add a rule.

#### Procedure

1. Start Call Center Elite Multichannel Control Panel.
2. In the left pane, expand the **Email Media Stores** node.
3. Expand the **Email Media Store** node.
4. Right-click the **Rules** node and click **Add Rule**.

The system displays the **Add Rule** tab in the right pane.

5. In the **Rule Name** section, enter a unique name for the rule.

#### **Important:**

The name of the rule is not case-sensitive. Ensure that you do not add any spaces before and after the rule name.

6. In the **Include Words** section, perform the following steps:
  - a. Enter a keyword in the **Keyword** field.

 **Important:**

When you enter a value in the **Keyword** field, ensure the following:

- Enter only alphanumeric value without spaces or special characters.
- Enter at least one keyword in the **Include Words** or **Exclude Words** section.
- Enter different keywords in the **Include Words** and **Exclude Words** sections.
- Do not enter the same keyword using different case. Keywords are not case-sensitive.

- b. Select the **OR** or **AND** connection option.

Based on the connection type, the system associates the keyword with other keywords in a keywords list.

- c. Click **Add**.

The system adds the keyword to the list.

7. In the **Exclude Words** section, perform the following steps:

- a. Enter a keyword in the **Keyword** field.
- b. Click **Add**.

The system adds the keyword in the list.

8. In the **Content Analysis** section, perform one of the following steps:

- If you want the system to search the keywords in the subject of an email, select the **Subject** check box.
- If you want the system to search the keywords in the body of an email, select the **Body** check box.
- If you want the system to search the keywords in the subject and body of an email, select both the check boxes.

9. Right-click anywhere on the **Add Rule** tab and click **Save and Close**.

 **Note:**

EMS matches the rule only when keywords in the **Include Words** list are present in an email and keywords in the **Exclude Words** list are not present in an email.

## Editing a rule

### About this task

Using the following procedure, you can edit a rule.

### Procedure

1. Start Call Center Elite Multichannel Control Panel.
2. In the left pane, expand the **Email Media Stores** node.
3. Expand the **Email Media Store** node.

4. Expand the **Rules** node.
5. Right-click the rule that you want to edit and click **Edit**.
6. On the **Edit Rule** tab, modify the values in the fields.
7. Right-click anywhere on the **Edit Rule** tab and click **Save and Close**.

## Deleting a rule

### About this task

Using the following procedure, you can delete a rule.

#### **Important:**

Before deleting a rule, ensure the following points:

- Do not try to delete a rule when you are editing a queue to which you have assigned that rule.
- Do not try to delete a rule that you are editing.

### Procedure

1. Start Call Center Elite Multichannel Control Panel.
2. In the left pane, expand the **Email Media Stores** node.
3. Expand the **Email Media Store** node.
4. Expand the **Rules** node.
5. Right-click the rule that you want to delete and click **Delete Rule**.
6. Click **Yes**.

#### **Note:**

When you delete a rule, the system automatically removes the association of that rule from all the queues to which it was assigned.

---

## Preview Contact Media Store

Preview Contact Media Store is one of many data stores that interact with the Media Director, Media Proxy, and Call Center Elite Multichannel Desktop to deliver non-voice work items to contact center agents.

By running as a service in the Preview Contact media store, you can blend on-screen customer contact prompts with inbound or outbound calls. You can perform the action essentially using this work to fill in the gaps between peaks in inbound call traffic.

Preview contact is defined as distributing a customer record to an agent so that the agent can initiate contact with the customer by phone.

Installed on a system that runs Microsoft Windows 2008 R2 SP1 Server 64-bit or Microsoft Windows 2008 SP2 Server 32-bit or 64-bit for example, Enterprise and Standard, Preview Contact Media

Store retrieves contact details from a SQL database. The task to contact a group of contacts is defined as a campaign in the database. The campaign instructs to start at a certain date or time and run till another date or time. The campaign can run over multiple time periods and can be recursive that is, starting every Monday morning at 9:00.

You can schedule campaigns to coincide with:

- Different shifts.
- Quieter times of the day that is low-peak call times.
- Times of the day that is the convenient time to contact customers.

A campaign configuration identifies which queue work items must queue to and the priority within that queue.

## Preview Contact Media Store startup

Preview Contact Media Store is a service that starts with the operating system. After loading configuration data via the Configuration Client, Preview Contact Media store starts logging errors and connects to the Media Director via the .Net Remoting framework. After the connection establishes, Preview Contact Media Store connects to the SQL database and is ready to load campaign data.

Preview Contact Media Store continuously polls the SQL database for changes in campaigns and campaign schedules.

## Viewing programs

### About this task

Using this procedure, you can view the programs available to this Preview Contact Media Store.

### Procedure

1. Start Call Center Elite Multichannel Control Panel.
2. In the left pane, expand the **Preview Contact Media Stores** node.
3. Expand the **Preview Contact Media Store** node.
4. Expand the **Interactions** node.

The configured Media Store that is connected to the **ASMediaStore** database displays programs from the **ASMediaStore** database and makes these programs available to use.

#### **Important:**

In the interactions list, you cannot run a program if **ASMediaStore** is disabled or does not have contacts assigned to **ASMediaStore**. The exception to **ASMediaStore** is that a program is designed exclusively for routing Microsoft Dynamics CRM activities.

## Creating a list of interactions

### About this task

Using this procedure, you can create a list of interactions or assign a group of contacts to a particular program.

### Procedure

1. Start Call Center Elite Multichannel Control Panel.
2. In the left pane, expand the **Preview Contact Media Stores** node.
3. Expand the **Preview Contact Media Store** node.
4. Expand the **Interactions** node.
5. Right-click a program and click **Load New Interactions**.
6. On the **Load Interactions** tab, perform the following steps:
  - a. Click **Browse** to locate the .csv or Excel file for saved contacts.

The system matches the column headings from the selected file with the columns in the database and accordingly displays the column headings from the .csv file in the appropriate fields on the **Load Interactions** tab.

 **Note:**

To display the customer contact records as a part of the Preview Contact work item, the Customer ID must match the Contact ID in the **ASContact** database.

- b. If a field displays incorrect column heading, click the drop-down button for that field and select the appropriate column heading.

 **Note:**

You can send out multiple messages by specifying multiple methods of contact and media store types.

- c. Click **Start**.

The system saves the contact list in the **ASMediaStore** database and displays the details in the **Program** node.

---

## Voice Media Store

Voice Media Store delivers voice work item that is a visual representation of a phone call to contact center agents via Call Center Elite Multichannel Desktop.

Voice work items are “answered” by agents who verbally respond to a customer inquiry while processing and closing the work item on the agent screen.

Agents can use any number of the features available to agents via Call Center Elite Multichannel Desktop, such as:

- Assigning a work code to the agent voice work item.
- Recording notes for agent voice work item or displaying previously made notes for a work item that has history.
- Printing all information related to agent voice work item.
- Inserting auto-text into the agent work item notes or any text field on a customized vertical tab.
- Viewing the conversation history of a customer, or retrieving a work item that was previously closed.

Voice work items are stored as other multimedia work items for example, email or simple message work items, in the ASMSControl Database and ASMSData Databases.

As this work item shows, Voice Media Store creates and stores a sequence of data that shows the progress of the call through various devices within the Communication Manager:

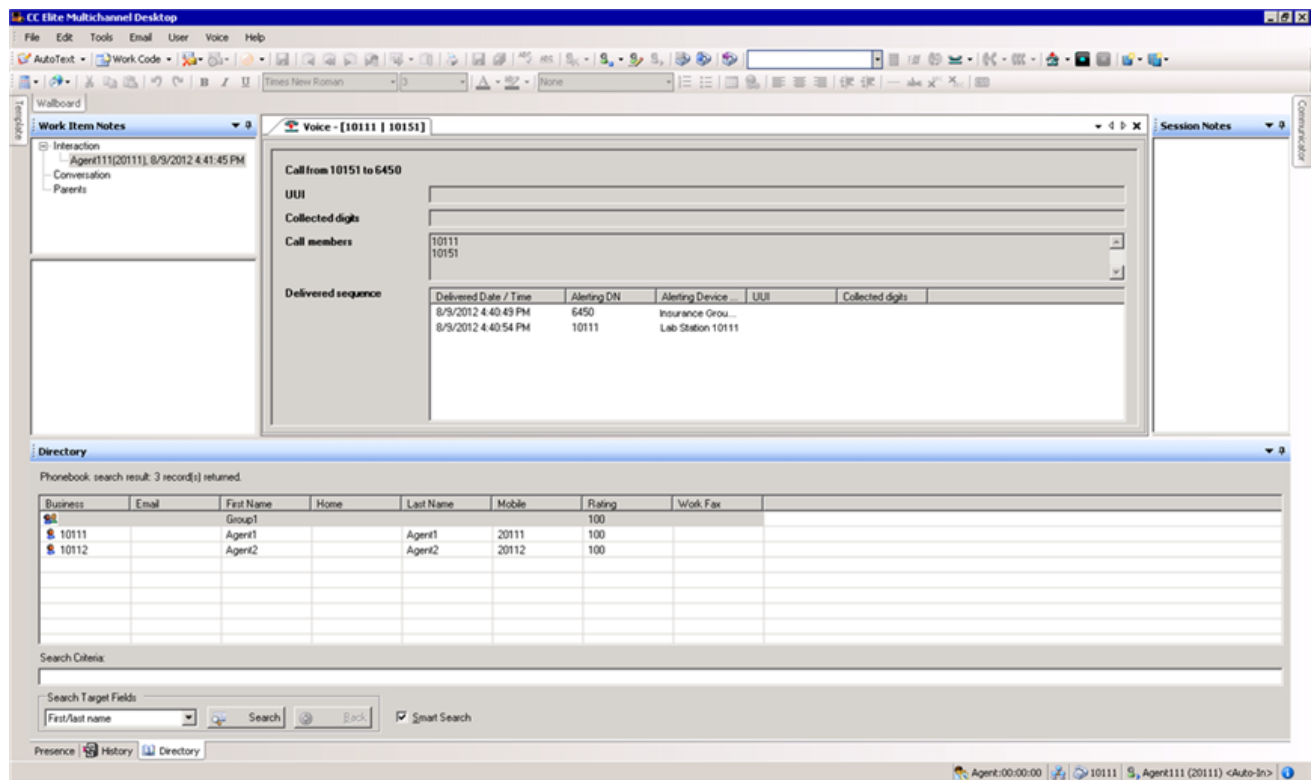

If the customer calling number matches with a contact record in the ASContact Database, a vertical **Contact** tab displays on the left as part of the work item.

While handling this inquiry, an agent can click this tab and edit the customer contact record. If the customer does not match with a contact record, the agent can create a new contact record and associate the customer with this work item. Next time the customer makes contact, the contact record automatically displays as part of the work item. Each contact record has a unique Contact ID as listed at the top of the Contact tab.

## VDN Groups

Voice Media Store supports a variable number of VDN groups that is, collections of VDNs that are used for a single purpose. For example, line of business that is sales and service. Each connection to an XML Server can be assigned one or more of these VDN groups.

## Configuring VDN Groups

### Procedure

1. Start Call Center Elite Multichannel Control Panel.
2. In the left pane, expand the **Voice Media Stores** node.
3. Expand the **Voice Media Store** node.

4. Expand the **VDN Groups** node.
5. Right-click the node that you want to configure and click **Edit**.

**\* Note:**

The **Group1** node is present by default.

6. On the **Edit VDN Group** tab, enter appropriate values in the fields.
7. Right-click anywhere on the **Edit VDN Group** tab and click **Save And Close**.

**Related Links**

[Edit VDN Group field descriptions](#) on page 88

**Adding VDN Groups**

**Procedure**

1. Start Call Center Elite Multichannel Control Panel.
2. In the left pane, expand the **Voice Media Stores** node.
3. Expand the **Voice Media Store** node.
4. Right-click the **VDN Groups** node and click **Add VDN Group**.
5. On the **Add VDN Group** tab, enter appropriate values in the fields.
6. Enter appropriate values in the fields on the following tabs:
  - Abandoned Call Assistant.
  - Customer Identification Assistant.
  - Customer Related Callback.

**\* Note:**

The features exist on a per VDN Group basis except for the Station Missed Call Mailer.

**Edit VDN Group field descriptions**

Name	Description
<b>VDN Group</b>	
<b>VDN group name</b>	The group name for related VDNs.
<b>VDN list</b>	A comma separated list of Communication Manager VDN extension numbers that are monitored by Voice Media Store. By monitoring the VDN, Voice Media Store receives call information events as the call transits the way through the Communication Manager ACD to an agent that is, each step in the calls progress can then be monitored and recorded into the Call Center Elite Multichannel database.

*Table continues...*



Name	Description
	With the ellipses (...) button next to this field, you can select the VDN numbers configured in Communication Manager.
<b>Program ID</b>	<p>The ID of a program you want to use for work items generated for phone calls that queues to the selected VDNs.</p> <p>The Program ID that is assigned to all voice interactions which generates from call activity of the monitored VDN. This program ID determines the auto text and work code groups that are available to the Call Center Elite Multichannel Desktop user when the call is delivered to desktop of the user.</p> <p> <b>Note:</b></p> <p>This program ID value overrides any other program ID associated with the call. For example, the program ID specified by the XML Server or a previous VDN.</p>
<b>Program ID Override</b>	<p>With this check box, Voice Media Store can override a previously assigned program ID from another VDN group if a call transitions into this VDN group.</p> <p>For example, if a call arrived for the Sales VDN group and is assigned the Sales Program ID - this would give the agent receiving the call the Sales auto text and work codes to use for the call. However, if the call was then transferred to Service via a different VDN Group, the program ID updates to Service with this configuration item. The agent receiving the second part of the call has the correct auto text and work codes to use for the call.</p> <p>Clear the <b>Program ID Override</b> check box if you want work items to keep the program ID set by the previous VDN or XML Server. Select the <b>Program ID Override</b> check box if you want the program ID to override by the value specified in the Program ID parameter</p>
<b>Routing VDN Group</b>	<p>This check box indicates that the VDN group will be used for adjunct routing functionality from Communication Manager. If the check box is checked, Voice Media Store monitors the VDNs and also registers for routing requests.</p> <p>Some enhanced features of Voice Media Store such as Customer Identification Assistant that requires the VDN group to be configured for Routing, facilitates</p>

*Table continues...*

Name	Description
	<p>the Voice Media Store to take control of the call and make decisions on the next step of call.</p> <p>Select the <b>Routing VDN Group</b> check box if you want VMS to register the VDNs in this group for routing operations.</p> <p> <b>Note:</b></p> <p>You must select this check box to use the Customer Identification Assistant feature.</p>

## Abandoned Call Assistant

With Voice Media Store, you can specifically cater for customers who call your call center, but end up by abandoning or ending the call before an agent answers the call.

By using the service, Abandoned Call Assistant, you can automatically generate a new “call back” work item that is, Preview Contact work item. Preview Contact work item displays on an agent screen for a certain time after the call is abandoned. You can configure the work item to be delivered at any time that suits the workload of your call center.

When a call comes to a VDN group and the call clears without being answered, the Voice Media Store performs some simple checking. This simple checking is to determine whether an automatic call back should be attempted. If the checks pass, then a Preview Contact outbound request is created. This new outbound Interaction is assigned to the same conversation as the voice interaction and has the voice Interaction ID as parent outbound interaction. With this action, the information becomes visible to the History Plug-in when the agent receives the Preview Contact. For Reporting, History Plug-in can be enabled or disabled on a VDN group basis.

## Configuring Abandoned Call Assistant

### Procedure

1. Start Call Center Elite Multichannel Control Panel.
2. In the left pane, expand the **Voice Media Stores** node.
3. Expand the **Voice Media Store** node.
4. Expand the **VDN Groups** node.
5. Right-click the VDN Group that you want to configure and click **Edit**.
6. On the **Edit VDN Group** tab, click the **Abandoned Call Assistant** tab and edit the required fields.
7. Right-click anywhere on the **Abandoned Call Assistant** tab and click **Save**.

## Abandoned Call Assistant field descriptions

Name	Description
<b>Enable Abandon Call Assistant</b>	This field determines whether the feature is enabled or disabled for a VDN group.
<b>Excluded VDNs</b>	There are some valid situations where the call flow within Communication Manager quits the call before the call is answered. This action is most common in an after-hours situation where the caller is played a message and the call then ends. In these situations there is possibility that the call is not seen as an abandon, but as a correct termination, and no outbound item generates into the Preview Contact program. This configuration item is a list of VDNs and must be a subset of the VDN group list. If a caller is abandoned in the queue and the last VDN in the delivered sequence is in this list, the call cannot add an outbound item to the Preview Contact program.
<b>Minimum Call Duration Seconds</b>	This time represents the minimum time that must elapse between the call arriving and abandoning, before the time is considered for this feature. This feature is designed to weed out calls that abandon immediately and must not really be considered for call-back. The default value for this parameter is 5 seconds. The minimum value is 0 with no maximum value.
<b>Only Identified Callers</b>	This ensures only callers that are positively identified via the ASContact Database that are added as a Preview Contact work item to the ASMSControl Database. If this value is true and the caller is not positively identified, the abandon call does not add an outbound item to the Preview Contact program. If this value is false, any abandon call can add an outbound item to the Preview Contact program.
<b>Required Group Membership</b>	This configuration item represents the mandatory ASContact Database group that the contact must belong to in order to be added as an abandoned call. This value can be empty which indicates no group membership is required.
<b>Excluded Group Membership.</b>	This configuration item represents an ASContact Database group that can be used to exclude contacts from being included in this feature.

*Table continues...*

Name	Description
	<p> <b>Note:</b></p> <p>Where the contact displays in both the <b>Required</b> and <b>Excluded</b> group, the <b>Excluded</b> group can take precedence.</p>
<b>Preview Contact Media Store URL</b>	The URL of the Preview Contact Program that specifies which media store can be used to create the call back work item. This configuration property is common across all features in the VDN group.
<b>Abandoned Call Preview Contact Program ID</b>	The program identifier that instructs the media store which Preview Contact Program the outbound requests will be placed when a caller abandons in the queue.
<b>Abandoned Call Suspend Offset</b>	<p>The amount of time the Preview Contact interaction suspends after the Voice Media Store has created it. Default is 0: This must make the call back work item immediately available.</p> <p>This value can be empty, which indicates that no contacts exclude based on group membership.</p>

## Customer Requested Callback

This feature operates in a similar manner to the Abandoned Call Assistant so that it automatically creates a new Preview Contact work item when the call reaches a particular point in the call workflow. The call back work item is delivered to an agent for processing based on the schedule used by the Media Store. You can use this feature to contact customers who call your call center after hours. In this case, the Customer Requested Callback feature can be configured to trigger when a customer calls after hours and hears the after-hours recorded message. For example, the customer is offered the option to request a call back in the Communication Manager vector, if selected a Customer requested call back generates. However, the call back is not for every after hours call.

## Configuring Customer Requested Callback Procedure

1. Start Call Center Elite Multichannel Control Panel.
2. In the left pane, expand the **Voice Media Stores** node.
3. Expand the **Voice Media Store** node.
4. Expand the **VDN Groups** node.
5. Right-click the VDN Group that you want to configure and click **Edit**.
6. On the **Edit VDN Group** tab, click the **Customer Requested Callback** tab and edit the required fields.
7. Right-click anywhere on the **Edit VDN Group** tab and click **Save**.

## Customer Requested Callback field descriptions

Name	Description
<b>Enable Customer Requested Callback</b>	This determines whether the feature is enabled or disabled for a VDN group.
<b>Callback VDN.</b>	The VDN that can be used as the trigger for the call back request to be created. This can be a single VDN and must be part of the VDN group. The call back request can be triggered when the call arrives at this VDN.
<b>Preview Contact Media Store URL</b>	This is the URL of the Media Store that is used to create the call back work item. This configuration property is common across all features in the VDN group.
<b>Callback Preview Contact Program ID</b>	This field identifies the Preview Contact Program where outbound requests can be placed when a caller reaches the Callback VDN.
<b>Callback Suspend Offset</b>	The duration for which the Preview Contact interaction suspends after the Voice Media Store has created it and before call back call work item is delivered to an agent. The default value is 0.

## Customer Identification Assistant

The Customer Identification Assistant serves to increase the chances of a caller being identified in the ASContact Database. With this assistant, you can select three pieces of call data, for example, calling number, user-entered digits that are checked against specific fields in the database. If a match is available, the call is redirected to a specific destination. If no match is available, the call is redirected to an alternate destination. If the call has cycled through this checking process more than a defined number of times, the call can be directed to another destination.

You can configure the feature to cycle a call through the checking process more than once.

### **Note:**

For this feature to be available to the Administrator, the VDN group must be setup as a routing group in Call Center Elite Multichannel Control Panel.

## Configuring Customer Identification Assistant

### Procedure

1. Start Call Center Elite Multichannel Control Panel.
2. In the left pane, expand the **Voice Media Stores** node.
3. Expand the **Voice Media Store** node.
4. Expand the **VDN Groups** node.
5. Right-click the VDN Group that you want to configure and click **Edit**.

6. On the **Edit VDN Group** tab, click the **Customer Identification Assistant** tab and edit the required fields.
7. Right-click anywhere on the **Edit VDN Group** tab and click **Save**.

### Customer Identification Assistant field descriptions

Name	Description
<b>Enable Customer Identification Assistant</b>	<p>This determines whether the feature is enabled or disabled for a VDN group.</p> <p>Select this check box to use the Customer Identification Assistant feature.</p> <p> <b>Note:</b></p> <p>To enable the form, you must register this VDN group for routing operations by selecting the Routing VDN group check box.</p>
<b>Skip Feature If Contact ID Populated</b>	<p>This value decides how Voice Media Store behaves when the feature is triggered for an interaction that already contains a ContactID.</p> <p>If this value is true and the feature is triggered for an Interaction with a populated ContactID, the call can be immediately routed to the value specified by <b>Success Destination</b>. If the value is false and the feature is triggered with a populated ContactID, the ContactID property can be cleared and feature processing proceeds as normal.</p> <p>Select this check box if you want to disable this feature for work items that contain the contact ID. The contact ID can be a GUID, an email address, or a customer name.</p>
<b>VDN</b>	<p>This specifies the VDN number that triggers the Customer Identification Assistant feature to be activated. This VDN number can only be a single value, and must be a member of the VDN group.</p>
<b>First Option Call Data</b>	<p>This is the name of a call value that are checked against the ASContact Database to find a match.</p> <p>If a match is available, the process ends successfully. If not, a match is searched for using the second option, and then failing that, the third.</p> <p>The Administrator is presented with a list of values that can be retrieved from the call for checking with the ASContact Database. Possible values are:</p> <ul style="list-style-type: none"> <li>• Calling Number</li> <li>• Called Number</li> </ul>

*Table continues...*

Name	Description
	<ul style="list-style-type: none"> <li>• User Entered Code</li> <li>• User to User Information</li> </ul>
<b>First Option Contact Field</b>	This is the name of the field within the ASContact Database that VMS checks for the first match with the data from the call specified by First Contact Call Data.
<b>Second Option Call Data</b>	The name of a call value which is checked against the ASContact Database to find a match. This is the second set of data to be checked.
<b>Second Option Contact Field</b>	This is the name of the field within the ASContact Database that VMS checks for the second match with the data from the call specified by First Contact Call Data.
<b>Third Option Call Data</b>	The name of a call value which is checked against the ASContact Database to find a match. This is the third and final set of data to be checked.
<b>Third Option Contact Field</b>	This is the name of the field within the ASContact Database that VMS checks for the third match with the data from the call specified by First Contact Call Data.
<b>Success Destination</b>	This is the destination number where the call is redirected to, if one of the checks with the ASContact Database provides a successful match.
<b>Failure Destination</b>	This is the destination number where the call is redirected to, if none of the checks with the ASContact Database provides a successful match.
<b>Maximum Tries</b>	<p>This is the number of times a single call can pass through this feature for checking. Internally, Interaction data for VMS stores the count of the number of times this feature is invoked.</p> <p>This count is incremented each time the feature starts. The count is cleared when the call is routed to the <b>Success Destination</b> or to the <b>Maximum Tries Exceeded Destination</b>.</p>
<b>Maximum Tries Exceeded Destination</b>	<p>The VDN or station number to which the system redirects the calls if a call passes through the feature for maximum number of times specified in the <b>Maximum Tries</b> field, but fails to match any records in the ASContact database.</p> <p> <b>Note:</b></p> <p>This parameter assumes you have set the Maximum tries parameter to two or more.</p>

## Private VDN

The default behavior of the Voice Media Store is to collect the path of the call, and simultaneously record and display any user-to-user information and user-entered digits as part of the work item. To overcome any privacy issues with this behavior, you can specify a list of VDNs you want to treat as private. As a result, Voice Media Store does not record user-to-user information and user-entered digits for these VDNs.

## Configuring Private VDN

### About this task

Use Call Center Elite Multichannel Control Panel to tailor VDN Privacy to your needs.

### Procedure

1. Start Call Center Elite Multichannel Control Panel.
2. In the left pane, expand the **Voice Media Stores** node.
3. Expand the **Voice Media Store** node.
4. Expand the **VDN Groups** node.
5. Right-click the VDN Group that you want to configure and click **Edit**.
6. On the **Edit VDN Group** tab, click the **Private VDN** tab.

**Private VDN:** This list is a subset of the VDNs that belong to the group.

7. Check the boxes next to the VDNs that you want to mark as private.

This task ensures that these VDNs do not have collected digit and UUI information recorded.

8. Right-click anywhere on the **Edit VDN Group** tab and click **Save**.

---

## Simple Messaging Media Store

The Simple Messaging Media Store is one of many media stores that interact with the Media Director, Media Proxy and Call Center Elite Multichannel Desktop to deliver non-voice work items to contact center agents.

Running as a service, Simple Messaging Media Store sits between Media Director and the following simple messaging gateways: Web Chat Gateway, MSN Messenger Gateway, AOL-ICQ Instant Messenger Gateway, and Short Message Service Gateway.

Simple Messaging Media Store provides the common base messaging functionality required by these gateways, by which you can blend customer messages via email, a web chat, AOL or MSN sessions, and SMS with inbound or outbound telephone calls.

Simple Messaging Media Store is installed on a system running Microsoft Windows 2008 R2 SP1 Server (Enterprise and Standard) 64-bit or Microsoft Windows 2008 SP2 Server (Enterprise and



Standard) 32-bit or 64-bit, the Simple Messaging Media Store uses configuration data and the information specified in the database schema to:

- Send simple messages from different gateways to different Media Director queues.
- Give queuing priority to messages received from special customers.
- Reject messages from certain customers and automatically email the customer that this has happened.
- Only passes messages from certain customers to queue to certain Media Director queues.

## Viewing connected gateways

### About this task

To view the gateways connected to a Simple Messaging Media Store:

### Procedure

1. Start Call Center Elite Multichannel Control Panel.
2. In the left pane, expand the **Simple Messaging Media Stores** node.
3. Expand the **Simple Messaging Media Store** node.
4. Expand the **Gateways** node.

The **Gateways** node lists the connected gateways.

---

## Backup / Restore / Delete databases

If you are using SQL Server the simplest way to backup, restore, and delete Call Center Elite Multichannel databases is via Microsoft GUI management tool that is, SQL Server Management Studio Express.

SQL Server Management Studio Express is automatically installed with the full version of SQL Server. However, you can download SQL Server Management Studio Express from Microsoft's website.

<http://search.microsoft.com/en-us/DownloadResults.aspx?q=Management+Studio+Express>

---

## Media Store databases migration

For detailed information on database migration, see *Avaya Aura® Call Center Elite Multichannel Upgrade and Migration Guide* available at the Avaya support Web site: <http://support.avaya.com>.

---

## Assigning a canned message group to a program

---

### Experience Portal Management Server

In Call Center Elite Multichannel Control Panel, you can configure Experience Portal Management Server (EPMS). After you configure EPMS, you can view and configure the features from Experience Portal (AAEP).

 **Note:**

After you open Experience Portal in Call Center Elite Multichannel Control Panel, if the Experience Portal system logs you out, you must close the Experience Portal Express document window and access the application again.

### Configuring EPMS

#### About this task

To configure EPMS:

#### Procedure

1. Start Call Center Elite Multichannel Control Panel.
2. In the left pane, expand the **Experience Portal Management Server** node.
3. Expand the **Experience Portal Config Service** node.
4. Right-click the **Experience Portal Express Setup** node and click **Edit**.
5. On the **Edit AP Express** tab, perform the following steps:
  - a. In the **Experience Portal server URL** field, enter the URL of the Experience Portal server that you have configured.
  - b. In the **User Name** and **Password** fields, enter the user name and password to access the Experience Portal server.

When you open Experience Portal, the system automatically logs in to Experience Portal using the specified user name and password.

If you do not enter the user name and password, you must enter the user name and password when you open Experience Portal.

6. Right-click anywhere on the **Edit EP Express** tab and click **Save And Close**.

### Accessing Experience Portal

#### Procedure

1. Start Call Center Elite Multichannel Control Panel.
2. In the left pane, expand the **Experience Portal Management Server** node.
3. Expand the **Experience Portal Config Service** node.

4. Right-click the **Experience Portal Express Setup** node and click **Open**.

The system opens Experience Portal in a new document window. You can access and configure all features of Experience Portal in this document window.

---

## TTrace config tool to send automatic email on configurable alarms

Using the TTraceConfig tool, you can configure an email ID where TTrace Server sends an automatic email for an alarm that the system logs on TTrace Server.

In Call Center Elite Multichannel, all servers raise different alarms. The state of each alarm can be RAISED, UPDATED, or CLEARED. For more information about alarms, see [Alarms and notifications](#) on page 341.

The system logs each alarm in one of the following formats:

```
Alarm [<digits>] RAISED <GUID of alarm> "<alarmname>" <alarmseverity> "<appname>" <?
xml version="1.0" ...
Alarm [<digits>] UPDATED <GUID of alarm> "<alarmname>" <alarmseverity> "<appname>" <?
xml version="1.0" ...
Alarm [<digits>] CLEARED <GUID of alarm> "<alarmname>" <alarmseverity> "<appname>" <?
xml version="1.0" ...
```

When a service running in Call Center Elite Multichannel generates an alarm or notification, Application Management Director (AMD) collects the alarm or notification. Application Management Director (AMD) then logs the alarm or notification into the log file of AMD on TTrace Server. AMD also sends the logged alarm or notification to Control Panel. For more information about logging, see [Log files in Call Center Elite Multichannel](#) on page 335.

When AMD logs an alarm or notification on TTrace Server, the TTrace Server sends an email with the alarm or notification details to the configured email ID, based on the predefined rules.

To configure automatic email, you must configure the **Emails** and **LogScan** options in the TTrace config tool. For information about how to configure emails and log scans, see *Avaya Aura® Call Center Elite Multichannel TTrace Console User Guide*.

# Chapter 5: Configuring Call Center Elite Multichannel core services

---

## Prerequisites for configuring Call Center Elite Multichannel core services

The following are the prerequisites for configuring Call Center Elite Multichannel core services:

- Communication Manager must be configured.
- Application Enablement Server (AES) must be up and running.
- Call Center Elite Multichannel licenses must be available on WebLM server.
- TSAPI client must be installed and configured on Call Center Elite Multichannel core and Interaction Data Server.

---

## Configuring License Director

### About this task

You can configure License Director to get licenses from WebLM server. License Director checks out licenses when WebLM Server starts and releases licenses when WebLM Server shuts down. When the connection between WebLM Server and License Director breaks:

- WebLM Server does not receive new requests from License Director and after a timeout period of 600 seconds, WebLM Server releases the checked out licenses.
- License Director fails to send new requests. Also, License Director immediately releases all checked out licenses and tries to check out the licenses again every 30 seconds.

### Procedure

1. Start Call Center Elite Multichannel Control Panel.
2. In the left pane, expand the **License Directors** node.
3. Right-click the **License Director** node and click **Edit**.
4. On the **Edit License Director** tab, enter appropriate values in the fields.
5. Right-click anywhere on the **Edit License Director** tab and click **Save And Close**.

**\* Note:**

When you use WebLM Server for licenses:

- If you change the WebLM configuration, you must restart License Director.
- If multiple License Directors are available, you must assign each License Director to a separate WebLM Server. You can install WebLM Server either on the same system where Call Center Elite Multichannel Control Panel is installed, or on a standalone system in the network.
- You cannot add or delete licenses through Call Center Elite Multichannel Control Panel. You must add the required licenses to WebLM Server through the WebLM Server interface.

### Related Links

[Edit License Director field descriptions](#) on page 101

## Edit License Director field descriptions

Name	Description
<b>Error Logging</b>	In the <b>Error Logging</b> section, you can specify the field values as mentioned in <a href="#">Error Logging</a> on page 339.
<b>Master License Director</b>	
<b>Master License Director management URL</b>	<p>You can click <b>Master License Director management URL</b> field to select a location of the master License Director, which the system can use when License Director exhausts all available licenses and need to borrow licenses from the master server.</p> <p><b>* Note:</b></p> <p>Enter the URL in the following format:</p> <pre>gtcp://&lt;server_system_name&gt;:29073/ASLicenseDirectorManagement.rem</pre>
<b>WebLM Server</b>	
<b>WebLM server URL</b>	<p>The URL of the WebLM server. License Director uses this WebLM server to retrieve the required licenses.</p> <p><b>* Note:</b></p> <p>Enter the URL in the following format:</p>

*Table continues...*

Name	Description
	<p>https:// &lt;WebLM_server_name&gt;:&lt;port_number&gt;/ WebLM/LicenseServer</p> <p>The port_number is the port, which the system uses to access the WebLM server. The default is 52233.</p>
<b>Renew interval (sec)</b>	<p>The time interval in seconds. After the set time, License Director renews all WebLM licenses. The default is 30 seconds.</p> <p>If License Director fails to renew the licenses, it frees or releases all checked out licenses and try to renew the licenses after 30 seconds.</p>

---

## Configuring Application Management Service

### About this task

For information about configuring Application Management Service, see [Application Management Service common configurable components](#) on page 413.

---

## Configuring an XML server

### Procedure

1. Start Call Center Elite Multichannel Control Panel.
2. In the left pane, expand the **XML Servers** node.
3. Right-click the **XML Server** node and click **Edit**.
4. On the **Edit XML Server** tab, enter appropriate values in the fields.
5. Right-click anywhere on the **Edit XML Server** tab and click **Save And Close**.

### Related Links

[Edit XML Server field descriptions](#) on page 102

---

## Edit XML Server field descriptions

Name	Description
License Director	

*Table continues...*

Name	Description
License Director IP	The IP address of the License Director server that you have configured in Call Center Elite Multichannel.
License Director port	The port number to access the License Director server. The default port number is 29095.
Name Service	
Name service IP	The IP address of the XML server naming service. The default IP address is 0.0.0.0.
Name service port	<p>The port number to access the XML server naming service.</p> <p> <b>Note:</b></p> <p>After connecting to the specified port, the system displays a list of configured XML interfaces. An XML interface is a combination of IP address and port number of an XML server. You can select an XML interface to connect it for the naming service.</p> <p>The default port is 29096.</p>
Error Logging	You can enter the field values as mentioned in <a href="#">Error Logging</a> on page 339.

## Configuring Media Director

### Procedure

1. Start Call Center Elite Multichannel Control Panel.
2. In the left pane, expand the **Media Directors** node.
3. Right-click the **Media Director** node and click **Edit**.
4. On the **Edit Media Director** tab, enter appropriate values in the fields.
5. Right-click anywhere on the **Edit Media Director** tab and click **Save And Close**.

### Related Links

[Edit Media Director field descriptions](#) on page 104

## Edit Media Director field descriptions

Name	Description
<b>Error Logging</b>	In the <b>Error Logging</b> section, you can specify the field values as mentioned in <a href="#">Error Logging</a> on page 339.
<b>XML Server</b>	
<b>Primary IP</b>	The IP address of the primary XML server.
<b>Primary port</b>	The port number to access the primary XML server.
<b>Primary link</b>	The link to connect the primary XML server. You can click the button next to the field to retrieve the link.
<b>Secondary IP</b>	The IP address of the secondary XML server.
<b>Secondary port</b>	The port number to access the secondary XML server.
<b>Secondary link</b>	The link to connect the secondary XML server. You can click the button next to the field to retrieve the link.
<b>License Director</b>	
<b>Primary IP</b>	The IP address of the primary License Director server.
<b>Primary port</b>	The port number to access the primary License Director server.
<b>Secondary IP</b>	The IP address of the secondary License Director server.
<b>Secondary port</b>	The port number to access the secondary License Director server.
<b>Master Media Director</b>	
<b>Master Media Director management URL</b>	The URL of the master Media Director.



# Chapter 6: Configuring Voice channel

---

## Prerequisites for configuring Voice channel

The following are the prerequisites for configuring Voice channel:

- Call Center Elite Multichannel core services must be installed and running.
- Voice Media Store must be installed and running.

---

## Checklist for configuring Voice channel

The following checklist outlines the series of steps that you must perform to configure Voice channel.

Step	Task	✓
1	Create a schedule in Media Store Database	
2	(Optional) Create an AutoText group or Work Code	
3	Create a program in Media Store Database	
4	Assign a schedule to a program in Media Store Database	
5	Configure Voice Media Store	
6	Configure or add XML Server for Voice Media Store	

---

## Creating a schedule

### About this task

You can create and assign a schedule to a program. The system automatically executes the program at the scheduled date and time. You can create a schedule that runs daily or weekly or a schedule that runs only once.

You can also select the work type in a schedule. The work type determines if the system runs the schedule on a working day or on a holiday.

**Procedure**

1. Start Call Center Elite Multichannel Control Panel.
2. In the left pane, expand the **Database Management** node.
3. Expand the **Media Store Database** node.
4. Expand a specific database node.
5. Right-click **Schedules** and click **Add Schedule**.
6. On the **Add Schedule** tab, enter appropriate values in the fields.
7. Right-click anywhere on the **Add Schedule** tab and click **Save And Close**.

---

**Add Schedule field descriptions**

Name	Description
<b>Schedule</b>	
<b>Name</b>	The name for the new schedule
<b>Work type</b>	The type of work that you want to schedule. 0- Normal 1- Holiday
<b>Schedule Time</b>	
<b>Start</b>	The starting time of a schedule.
<b>End</b>	The ending time of a schedule.
<b>Duration</b>	The duration of the schedule.
<b>Schedule Type</b>	The type of schedule you want to run. The types of schedules you can run are: <ul style="list-style-type: none"> <li>• One off</li> <li>• Daily</li> <li>• Weekly</li> </ul>
<b>Schedule Date</b>	
<b>Start</b>	The start date of a schedule.
<b>End</b>	The end date of a schedule.

---

## Creating an AutoText group/Work Code

### About this task

You can create different AutoText groups to categorize different AutoText entries that agents can use when processing work items. This action helps the agents to find the required AutoText entry from the application menu bar.

### Procedure

1. Start Call Center Elite Multichannel Control Panel.
2. In the left pane, expand the **Database Management** node.
3. Expand the **Media Store Database** node.
4. Expand a specific database node where you want to create the AutoText group.
5. Right-click the **AutoText/Work Code** node and click **Add AutoText Group**.
6. On the **Add AutoText** tab, in the **AutoText group name** field, enter a name for the AutoText group.
7. Right-click anywhere on the **Add AutoText** tab and click **Save And Close**.

---

## Adding AutoText entries in an AutoText group

### About this task

When an agent selects an AutoText menu from Call Center Elite Multichannel Desktop, the AutoText plug-in scans the value of a selected AutoText for variables and replaces the variables with the correct value. The AutoText plug-in replaces the unknown or missing variables with a space or empty string.

### Procedure

1. Start Call Center Elite Multichannel Control Panel.
2. In the left pane, expand the **Database Management** node.
3. Expand the **Media Store Database** node.
4. Expand a specific database node.
5. Expand the **AutoText/Work Code** node.
6. Right-click an AutoText group name and click **Manage AutoText Items**.
7. On the **Manage AutoTexts** tab, enter appropriate values in the following fields:
  - Topic
  - Key
  - Values
8. Right-click anywhere on the **Manage AutoTexts** tab and click **Save And Close**.

**\* Note:**

For a unique topic name, you can have multiple topics with the same key within a particular group. Similarly, for a unique key, you can have multiple keys with the same topic.

You can copy and paste data from one AutoText group to another AutoText group, double-click a cell to edit the value of an AutoText entry, and right-click a cell and select an option to insert a predefined variable into the value of an AutoText entry.

**Related Links**

[Manage AutoTexts field descriptions](#) on page 108

[Supported variables in the AutoText Plug-in](#) on page 108

**Manage AutoTexts field descriptions**

Name	Description
<b>Topic</b>	This is the name of a group of the related AutoText entries or work codes. For example, Membership.
<b>Key</b>	This is the name of the AutoText or work code. For example, Join.
<b>Value</b>	This is the text that the system displays when an agent selects an AutoText key. For work codes, the value is a number. For example, 11.

**Supported variables in the AutoText Plug-in**

You can use the following variables in the AutoText Plug-in.

Name	Description
<i>StationDN</i>	The station number of the agent using Call Center Elite Multichannel Desktop.
<i>StationName</i>	The name configured in Communication Manager for the station of an agent using Call Center Elite Multichannel Desktop.
<i>AgentID</i>	The agent ID of an agent who is logged in to the station using Call Center Elite Multichannel Desktop. If no agent is logged in, the system displays this variable as blank.

*Table continues...*

Name	Description
<i>AgentName</i>	<p>The name configured in Communication Manager for an agent who is logged in to the station using Call Center Elite Multichannel Desktop.</p> <p>If no agent is logged in, this variable shows a blank value.</p>
<i>LoggedInUser</i>	<p>The user name of a person logged in to a system that runs Call Center Elite Multichannel Desktop.</p>
<i>MachineName</i>	<p>The name of a system that is running Call Center Elite Multichannel Desktop.</p>
<i>InteractionData</i>	<p>A variable with additional parameters that specifies a topic and a key for data. This data is held in the extra data table associated with the currently selected work item.</p> <p>In this variable, the topic parameter is optional. The topic and key parameters are separated by colon. If the key contains a single character, such as asterisks (*), all values that matches with the specified topic are inserted.</p> <p>For example: &lt;%InteractionData:SMMS:Message %&gt;.</p> <p>In this example, the system processes the queue configuration data associated with a current work item, locates the SMMS topic and a Message key, and inserts the contents of the value into this variable.</p>
<i>ProgramData</i>	<p>A variable with additional parameters that specify a topic and a key for data. This data is part of the queue configuration data associated with a currently selected work item.</p> <p>In this variable, the topic parameter is optional. The topic and key parameters are separated by colon. If the key contains a single character, such as asterisk (*), all values that matches with the specified topic are inserted.</p> <p>This functionality of this variable is identical to the <b>InteractionData</b> variable, but with a different source of information.</p> <p>For example: &lt;%ProgramData:SMMS:Message%&gt;.</p> <p>In this example, the system processes the queue configuration data associated with a current work item, locates the SMMS topic and a Message key,</p>

*Table continues...*

Name	Description
	and inserts the contents of the value into this variable.
<i>Break</i>	This variable inserts a carriage return line-feed combination into the text at the specified point.
<i>LongDate</i>	This variable inserts the current date in the Long format. The date is formatted using the desktop locale information.
<i>ShortDate</i>	This variable inserts the current date in the Short format. The date is formatted using the desktop locale information.
<i>LongTime</i>	This variable inserts the current time in the Long format. The time is formatted using the desktop locale information.
<i>ShortTime</i>	This variable inserts the current time in the Short format. The time is formatted using the desktop locale information.
<i>UniversalTime</i>	This variable inserts the current time converted to Coordinated Universal Time (UTC) format.
<i>Environment Variable</i>	<p>A variable with an additional parameter, which is an environment variable name. AutoText Plug-in retrieves the associated value of this variable and inserts the value in the AutoText entry. The variable name and environment variable name are separated by colon.</p> <p>Example: <code>&lt;%Environment:USERNAME%&gt;</code>.</p> <p>The system searches the USERNAME parameter in the system environment.</p>

## Creating a program

### About this task

You can create programs to perform the database-related activities.

 **Note:**

You can create a separate program to route Microsoft Dynamics CRM activities to Call Center Elite Multichannel Desktop agents. You can also create a separate program for outbound calls.

### Procedure

1. Start Call Center Elite Multichannel Control Panel.
2. In the left pane, expand the **Database Management** node.

3. Expand the **Media Store Database** node.
4. Expand the database node for which you want to create a program.
5. Right-click the **Programs** node and click **Add Program**.
6. On the **Add Program** tab, enter appropriate values in the fields.
7. Right-click anywhere on the **Add Program** tab and click **Save And Close**.

### Related Links

[Outbound programs for virtual agents](#) on page 215

## Add Program field descriptions



Name	Description
<b>Program</b>	
<b>Program ID</b>	A unique identifier for the program that you are currently creating.
<b>Name</b>	A common name for your program.
<b>Used by</b>	<p>The application that uses this program. For example, if you want Preview Contact Media Store to use this program, select the Preview Contact Media Store check box.</p> <p> <b>Note:</b></p> <p>If you create a new program for Preview Contact Media Store, the system displays the program in the <b>Interactions</b> list of Preview Contact Media Store, which connects to the same ASMediaStore database. From the Interactions list, you can assign a group of contacts to your program and save the contacts to the ASMediaStore Database. For more information, see <a href="#">Preview Contact Media Store</a> on page 83.</p>
<b>Description</b>	A brief description for your program.
<b>Prompt</b>	A welcome greeting that an agent use while contacting a customer.
<b>Service level seconds</b>	The service level time, in seconds, for the program created. Default is 0
<b>CC Elite Configuration tab - Program Configuration</b>	
<b>Auto Text list name</b>	An identifier for the AutoText group you want agents to view when the agents work on work items generated through this program.

*Table continues...*

Name	Description
<b>Canned Message list name</b>	A canned message group name from which you want to display the canned messages to customers.
<b>Program access mode</b>	A program is public that is, allowed or open, or private that is, denied or closed.
<b>CC Elite Configuration tab - Work Code</b>	
<b>Number of tab pages</b>	The number of tabs that you use for advanced work code. Default is 5.
<b>Minimum required work code(s)</b>	The minimum number of work codes that must be entered by the agent. Default is 1.
<b>Use Advanced Work Code style</b>	The check box to select advance work code style. The system disables the Standard work code list name field.
<b>Standard Work Code list name</b>	A name for the list of standard work codes that you have configured.
<b>Advanced Work Code list name</b>	The identifier of the AutoText group, in this case a group of work codes, that you want agents to view when agents work on work items generated through this program.
<b>Default work code</b>	The default work code. The default value is 0.
<b>CC Elite Configuration tab - Desktop Utility</b>	
<b>Automatically drop phantom call</b>	The check box to put an agent in the pending Auxiliary mode and drop the phantom call when the agent accepts a work item.
<b>Automatic drop reason code</b>	A reason code that the system uses when an agent enters in the Auxiliary mode. The default value is 0.
<b>Agent available on interaction close</b>	A condition based on which you want an agent to be available after the current interaction is closed.
<b>Auto accept non-voice interactions</b>	The check box to automatically accept all multimedia work items or interaction.
<b>CC Elite Configuration tab - Preview Contact Client</b>	
<b>Client action</b>	<p>An option that determines the behavior of Desktop when it receives a work item that the program you are configuring generates.</p> <ul style="list-style-type: none"> <li>• <b>0 - No action.</b> Call Center Elite Multichannel Desktop makes the contact information available to the agent. The agent initiates contact when ready.</li> <li>• <b>1 - Preview Contact.</b> Reserved for future use. If used, this option follows the behavior of 0 - No action.</li> <li>• <b>2 - Initiate Contact.</b> Desktop displays the contact information to an agent and automatically initiates</li> </ul>

*Table continues...*



Name	Description
	a call using the dial delay time specified in the <b>Auto dial delay (seconds)</b> parameter.
<b>Auto dial delay (seconds)</b>	The number of seconds Desktop waits after an agent receives a work item from a program. After the specified seconds, Desktop automatically dials a first number in the contact details. The default value is 20.
<b>Client window title</b>	The text that the system displays on the title bar of a Preview Contact work item window.
<b>CC Elite Outbound tab</b>	
<b>Available for outbound work</b>	An option that determines the state of an agent for an outbound work.
<b>Type of outbound work</b>	The type of an outbound work for an agent.
<b>Interaction ignored by AS client</b>	The check box to ignore the interactions of the current program.
<b>Associated program list</b>	A list of associated programs.
<b>Customized Configuration tab</b>	
<b>Key</b>	<p>The name of the associated data.</p> <p> <b>Note:</b></p> <p>This is the additional customer data that the system displays in a work item that agents receive.</p>
<b>Value</b>	<p>The value of the associated data.</p> <p> <b>Note:</b></p> <p>This is the additional customer data that the system displays in a work item that agents receive.</p>
<b>Topic</b>	<p>The optional topic to be used as a subgroup.</p> <p>This is the additional customer data that the system displays in a work item that agents receive.</p> <p> <b>Note:</b></p> <p>You can add the following key value pair that enables the system to correctly identify all <b>Microsoft Dynamics CRM</b> activities and route the activities to Call Center Elite Multichannel Desktop through the Microsoft Dynamics CRM GUI Plug-in.</p> <p><b>Key:</b> Work Item Type</p> <p><b>Value:</b> 100</p>

## Assigning a schedule to a program

### About this task

You can assign a schedule to a program to automatically run the program at a specified schedule. You can also assign more than one schedule to a single program.

After you assign a schedule to a program, the system automatically runs that program once, daily, or weekly. You can also specify time in a schedule.

### \* Note:

In Call Center Elite Multichannel, only one instance of a program schedule is active at a time. If the schedules of two programs overlap each other, the schedule that starts first takes the priority and the system ignores the other overlapping schedule.

### Procedure

1. Start Call Center Elite Multichannel Control Panel.
2. In the left pane, expand the **Database Management** node.
3. Expand the **Media Store Database** node.
4. Expand a specific database node.
5. Expand the **Programs** node.
6. Right-click a program node and click **Assign Schedule**.
7. On the **Assign Schedule** tab, enter appropriate values in the fields.
8. Right-click anywhere on the **Assign Schedule** tab and click **Save And Close**.

### Related Links

[Assign Schedule field descriptions](#) on page 114

## Assign Schedule field descriptions

Name	Description
<b>Schedule ID</b>	The field to select a schedule you want the program to use.  For more information about creating a schedule, see <a href="#">Creating a schedule</a> on page 105
<b>Resume type</b>	The field to select a behavior for the program when the program restarts at the selected schedule: <ul style="list-style-type: none"> <li>• <b>0-Resume</b>: The program restarts from the point where it stopped and stops when it is finished.</li> <li>• <b>1-Restart</b>: The program restarts from the beginning and stops when it is finished.</li> </ul>

*Table continues...*

Name	Description
	<ul style="list-style-type: none"> <li>• <b>2-Resume Restart:</b> The program restarts from the point it stopped, finishes, and restarts after it finishes.</li> </ul>
<b>Preview Contact Media Store</b>	
<b>Media director managed by control panel</b>	<p>Lists the media directors.</p> <p>Select the required media director to populate the drop-down list for Media director queue id.</p>
<b>Media director queue ID</b>	The Media Director queue ID for the Preview Contact work items.
<b>Queue priority</b>	The priority of queuing work items.

## Configuring Voice Media Store

### Before you begin

Ensure that you have installed Voice Media Store. For instructions on how to install Voice Media Store, see *Installing Avaya Aura® Call Center Elite Multichannel*.

### Procedure

1. Start Call Center Elite Multichannel Control Panel.
2. In the left pane, expand the **Voice Media Stores** node.
3. Right-click the **Voice Media Store** node and click **Edit**.
4. On the **Edit Voice Media Store** tab, enter appropriate values in the fields.
5. Right-click anywhere on the **Voice Media Store** tab and click **Save And Close**.

## Edit Voice Media Store field descriptions

Name	Description
<b>Media Director</b>	
<b>Media Director</b>	The Media Director server name.
<b>URL</b>	<p>The URL that VMS uses to connect to the Media Director server.</p> <p>The system forms this URL using the values that you specify in the IP, Port, Channel type, and URL fields.</p>
<b>IP</b>	The IP address of Media Director.

*Table continues...*

Name	Description
	The system automatically adds the IP address or host name of the Media Director server when you select a Media Director in the <b>Media Director</b> field.
<b>Port</b>	The port number to access the Media Director server. The default port number is 29087.
<b>Channel type</b>	The .Net remoting channel that the multimedia applications in Call Center Elite Multichannel use to communicate.  Default: gtcp.
<b>URI</b>	The Uniform Resource Identifier (URI) of the remote communication object factory on the Media Director server.  Default: RemoteFactory.rem.
<b>Error Logging</b>	You can enter the field values as mentioned in <a href="#">Error Logging</a> on page 339.
<b>Media Store Database</b>	
<b>Server name</b>	The server name on which you have configured the media store database.
<b>Database name</b>	The database name that you have configured for EMS.
<b>User name</b>	The user name to access the selected database.
<b>Password</b>	The password to access the selected database.
<b>Connection string</b>	The connection string based on the server and database you select.
<b>Test Connection</b>	A button to test if you can connect to the selected database on the selected server.
<b>Save empty UUI and collected digits</b>	You can clear this check box to conserve space in the database. By default this check box is selected.
<b>Contact Database</b>	
<b>Server name</b>	The name of a server on which you have configured the <b>ASContact</b> database.
<b>Database name</b>	The name of a database that you have configured for storing contacts.
<b>User name</b>	The user name to access the selected database.
<b>Password</b>	The password to access the selected database.
<b>Connection string</b>	The database connection string based on the server and database you select.
<b>Test Connection</b>	A button to test if you can connect to the selected database on the selected server.

## Configuring XML Server for Voice Media Store

### About this task

Using this procedure, you can edit an existing XML Server for Voice Media Store.

### Procedure

1. Start Call Center Elite Multichannel Control Panel.
2. In the left pane, expand the **Voice Media Stores** node.
3. Expand the **Voice Media Store** node.
4. Expand the **XML Servers** node.
5. Right-click the **XML Server** node and click **Edit**.
6. On the **Edit XML Server** tab, enter appropriate values in the fields.
7. Right-click anywhere on the **Edit XML Server** tab and click **Save And Close**.

## Edit XML Server for VMS field descriptions

Name	Description
<b>XML Server name</b>	The XML server name. The system displays this name as a node in the Call Center Elite Multichannel tree interface.
<b>Program ID</b>	The program that you want to use for all voice work items that the system generates through monitored stations or VDNs.   <b>Note:</b> The programs in the drop-down list are stored in the <b>ASMediaStore</b> database to which VMS is connected.
<b>Enable XML Server</b>	This check box helps you to enable or disable the XML Server.
<b>Primary XML Server IP</b>	The IP address of the XML server.
<b>Primary XML Server port</b>	The port number of the XML Server.
<b>Primary link name</b>	The link that this application uses to connect to the telephony server and the switch. Optionally, select a secondary XML server
<b>Secondary XML Server IP</b>	The IP address of the XML server.
<b>Secondary XML Server port</b>	The port number of the XML Server.

*Table continues...*

Name	Description
<b>Secondary link name</b>	The link that this application uses to connect to the telephony server and the switch. Optionally, select a secondary XML server.
<b>VDN group list</b>	<p>The VDN groups that Voice Media Store monitors.</p> <p> <b>Note:</b> If you did not set up the VDN groups earlier, you must complete this section later.</p>
<b>Station list</b>	<p>A comma-separated list of station numbers that VMS monitors and a hyphen must be used to indicate a range.</p> <p>Click the button next to this field to select the stations available in Communication Manager.</p>
<b>Station Missed Call Mailer</b>	<p>This feature is similar to Abandoned Call Assistant and Customer Requested Callback. The only exception is, with this feature, an email generates to the station owner when a call is received but not answered.</p> <p>This feature is activated for calls that arrive to the monitored station directly and not for calls that are delivered via a VDN. When a call is delivered to the monitored station and the call clears without being answered or (optionally) diverts, a record of this call is sent to the email address extracted from the ASContact Database for the station record.</p>
<b>Enable Missed Call Mailer</b>	This check box helps you to enable or disable the system to send missed called mailers
<b>Email for diverted calls</b>	<p>This field determines whether a call that diverts from the monitored device generates an email. The default for this is true. When false, only calls that clear while still ringing at the monitored device generates email. As calls that divert from the device are usually managed by other technology such as, voicemail, diverted calls are excluded.</p> <p>Select this check box if you want the system to generate an email for a call that diverts from the monitoring device</p>
<b>Contact station ID field</b>	The field in the ASContact Database that are used to match the configured station. With this field,you can match the extension number of the phone that is ringing, with a contact record in the ASContact Database.

*Table continues...*

Name	Description
<b>Contact email ID field for To address</b>	The field in the ASContact Database that can contain the email address where details of missed calls to a station are sent to the email address.
<b>Contact email ID field for CC address</b>	The field in the ASContact Database that contains the email address where details of missed calls to a station are copied.
<b>SMTP Server IP</b>	The IP address or server name of the SMTP server that are used to send emails for the missed calls.
<b>SMTP Server port</b>	The port number of the SMTP server that is used to send emails for this feature.
<b>CC address</b>	An email address that receives a copy of all missed call emails that are sent from the Voice Media Store. This CC address applies to all emails and is included with the CC address from the contact record. This is a list, separated by semicolons.
<b>BCC address</b>	An email address that receives a blind copy of all missed call emails sent from the Voice Media Store. This is a list, separated by semicolons.
<b>Email from address</b>	The 'from' address that are used to send the missed call mailers.
<b>Email reply-to address</b>	This specifies the email address used when the person receiving the email clicks the 'reply' button. This parameter is optional.
<b>Email subject</b>	<p>The subject that is added to the email as sent.</p> <p>Default value is "Missed Call From %CallingNumber %"</p> <p>The following are placeholders you can use in the subject of an email</p> <ul style="list-style-type: none"> <li>• %CalledNumber% - The number dialed.</li> <li>• %CallingNumber% - the calling party number for the call.</li> <li>• %CallingName% - The name from the contact database associated with the calling number. If this is unavailable then empty.</li> <li>• %CallingNameNumber% - The name from the contact database associated with the calling number if this is unavailable then the calling number.</li> <li>• %UUI% - Any UUI that is received with the call.</li> <li>• %CollectedDigits% - Any collected digits that are received with the call.</li> </ul>

*Table continues...*

Name	Description
	<ul style="list-style-type: none"> <li>• %StartDateTime% - The start date and time for the call.</li> <li>• %UCID% - The UCID associated with the call.</li> <li>• %InteractionID% - The interaction ID of the voice work item.</li> <li>• %ConversationID% - The conversation ID of the voice work item.</li> </ul>
<p><b>Email body</b></p>	<p>The body that is added to the email. The email body is in the plain text format.</p> <p>The default value is: "Call from %CallingNumber% was missed at %StartDateTime%"</p> <p>You can use the following placeholders in addition to the placeholders that you use in the <b>Email subject</b> field:</p> <ul style="list-style-type: none"> <li>• %CalledNumber% - The number dialed.</li> <li>• %CallingNumber% - The calling party number for the call.</li> <li>• %CallingName% - The name from the <b>ASContact</b> database associated with the calling number. If this is unavailable then empty.</li> <li>• %CallingNameNumber% - The name from the <b>ASContact</b> database associated with the calling number if this is unavailable then the calling number.</li> <li>• %UUI% - Any UUI that is received with the call.</li> <li>• %CollectedDigits% - Any collected digits that are received with the call.</li> <li>• %StartDateTime% - The start date and time for the call.</li> <li>• %UCID% - The UCID associated with the call.</li> <li>• %InteractionID% - The interaction ID of the voice work item</li> <li>• %ConversationID% - The conversation ID of the voice work item</li> <li>• %CR% - A new line in the email body.</li> </ul>



---

## Adding XML Server for Voice Media Store

### About this task

Using this procedure, you can add a new XML Server for Voice Media Store.

### Procedure

1. Start Call Center Elite Multichannel Control Panel.
2. In the left pane, expand the **Voice Media Stores** node.
3. Expand the **Voice Media Store** node.
4. Right-click the **XML Servers** node and click **Add XML Server**.
5. On the **Add XML Server** tab, enter appropriate values in the fields.

For detailed field descriptions, see [Edit XML Server for VMS field descriptions](#) on page 117.

6. Right-click anywhere on the **Add XML Server** tab and click **Save And Close**.

# Chapter 7: Configuring Email channel

---

## Prerequisites for configuring Email channel

The following are the prerequisites for configuring Email channel:

- Call Center Elite Multichannel core services must be installed and running.
- Email Media Store must be installed and running.
- Email Server must be configured and accessible.

---

## Checklist for configuring Email channel

The following checklist outlines the series of steps that you must consider to configure Email channel.

Step	Task	✓
1	Create a schedule in Media Store Database	
2	(Optional) Create an AutoText group/Work Code	
3	Create a program in Media Store Database	
4	Assign a schedule to a program in Media Store Database	
5	Create an Email queue in Media Director	
6	Configure Email Media Store	
7	Add a queue for Email Media Store	

---

## Creating a schedule

### About this task

You can create and assign a schedule to a program. The system automatically executes the program at the scheduled date and time. You can create a schedule that runs daily or weekly or a schedule that runs only once.

You can also select the work type in a schedule. The work type determines if the system runs the schedule on a working day or on a holiday.

## Procedure

1. Start Call Center Elite Multichannel Control Panel.
2. In the left pane, expand the **Database Management** node.
3. Expand the **Media Store Database** node.
4. Expand a specific database node.
5. Right-click **Schedules** and click **Add Schedule**.
6. On the **Add Schedule** tab, enter appropriate values in the fields.
7. Right-click anywhere on the **Add Schedule** tab and click **Save And Close**.

---

## Add Schedule field descriptions

Name	Description
<b>Schedule</b>	
<b>Name</b>	The name for the new schedule
<b>Work type</b>	The type of work that you want to schedule. 0- Normal 1- Holiday
<b>Schedule Time</b>	
<b>Start</b>	The starting time of a schedule.
<b>End</b>	The ending time of a schedule.
<b>Duration</b>	The duration of the schedule.
<b>Schedule Type</b>	The type of schedule you want to run. The types of schedules you can run are: <ul style="list-style-type: none"> <li>• One off</li> <li>• Daily</li> <li>• Weekly</li> </ul>
<b>Schedule Date</b>	
<b>Start</b>	The start date of a schedule.
<b>End</b>	The end date of a schedule.

---

## Creating an AutoText group/Work Code

### About this task

You can create different AutoText groups to categorize different AutoText entries that agents can use when processing work items. This action helps the agents to find the required AutoText entry from the application menu bar.

### Procedure

1. Start Call Center Elite Multichannel Control Panel.
2. In the left pane, expand the **Database Management** node.
3. Expand the **Media Store Database** node.
4. Expand a specific database node where you want to create the AutoText group.
5. Right-click the **AutoText/Work Code** node and click **Add AutoText Group**.
6. On the **Add AutoText** tab, in the **AutoText group name** field, enter a name for the AutoText group.
7. Right-click anywhere on the **Add AutoText** tab and click **Save And Close**.

---

## Adding AutoText entries in an AutoText group

### About this task

When an agent selects an AutoText menu from Call Center Elite Multichannel Desktop, the AutoText plug-in scans the value of a selected AutoText for variables and replaces the variables with the correct value. The AutoText plug-in replaces the unknown or missing variables with a space or empty string.

### Procedure

1. Start Call Center Elite Multichannel Control Panel.
2. In the left pane, expand the **Database Management** node.
3. Expand the **Media Store Database** node.
4. Expand a specific database node.
5. Expand the **AutoText/Work Code** node.
6. Right-click an AutoText group name and click **Manage AutoText Items**.
7. On the **Manage AutoTexts** tab, enter appropriate values in the following fields:
  - Topic
  - Key
  - Values
8. Right-click anywhere on the **Manage AutoTexts** tab and click **Save And Close**.

**\* Note:**

For a unique topic name, you can have multiple topics with the same key within a particular group. Similarly, for a unique key, you can have multiple keys with the same topic.

You can copy and paste data from one AutoText group to another AutoText group, double-click a cell to edit the value of an AutoText entry, and right-click a cell and select an option to insert a predefined variable into the value of an AutoText entry.

### Related Links

[Manage AutoTexts field descriptions](#) on page 108

[Supported variables in the AutoText Plug-in](#) on page 108

## Manage AutoTexts field descriptions

Name	Description
<b>Topic</b>	This is the name of a group of the related AutoText entries or work codes. For example, Membership.
<b>Key</b>	This is the name of the AutoText or work code. For example, Join.
<b>Value</b>	This is the text that the system displays when an agent selects an AutoText key. For work codes, the value is a number. For example, 11.

## Supported variables in the AutoText Plug-in

You can use the following variables in the AutoText Plug-in.

Name	Description
<i>StationDN</i>	The station number of the agent using Call Center Elite Multichannel Desktop.
<i>StationName</i>	The name configured in Communication Manager for the station of an agent using Call Center Elite Multichannel Desktop.
<i>AgentID</i>	The agent ID of an agent who is logged in to the station using Call Center Elite Multichannel Desktop. If no agent is logged in, the system displays this variable as blank.

*Table continues...*

Name	Description
<i>AgentName</i>	<p>The name configured in Communication Manager for an agent who is logged in to the station using Call Center Elite Multichannel Desktop.</p> <p>If no agent is logged in, this variable shows a blank value.</p>
<i>LoggedInUser</i>	<p>The user name of a person logged in to a system that runs Call Center Elite Multichannel Desktop.</p>
<i>MachineName</i>	<p>The name of a system that is running Call Center Elite Multichannel Desktop.</p>
<i>InteractionData</i>	<p>A variable with additional parameters that specifies a topic and a key for data. This data is held in the extra data table associated with the currently selected work item.</p> <p>In this variable, the topic parameter is optional. The topic and key parameters are separated by colon. If the key contains a single character, such as asterisks (*), all values that matches with the specified topic are inserted.</p> <p>For example: &lt;%InteractionData:SMMS:Message %&gt;.</p> <p>In this example, the system processes the queue configuration data associated with a current work item, locates the SMMS topic and a Message key, and inserts the contents of the value into this variable.</p>
<i>ProgramData</i>	<p>A variable with additional parameters that specify a topic and a key for data. This data is part of the queue configuration data associated with a currently selected work item.</p> <p>In this variable, the topic parameter is optional. The topic and key parameters are separated by colon. If the key contains a single character, such as asterisk (*), all values that matches with the specified topic are inserted.</p> <p>This functionality of this variable is identical to the <b>InteractionData</b> variable, but with a different source of information.</p> <p>For example: &lt;%ProgramData:SMMS:Message%&gt;.</p> <p>In this example, the system processes the queue configuration data associated with a current work item, locates the SMMS topic and a Message key,</p>

*Table continues...*

Name	Description
	and inserts the contents of the value into this variable.
<i>Break</i>	This variable inserts a carriage return line-feed combination into the text at the specified point.
<i>LongDate</i>	This variable inserts the current date in the Long format. The date is formatted using the desktop locale information.
<i>ShortDate</i>	This variable inserts the current date in the Short format. The date is formatted using the desktop locale information.
<i>LongTime</i>	This variable inserts the current time in the Long format. The time is formatted using the desktop locale information.
<i>ShortTime</i>	This variable inserts the current time in the Short format. The time is formatted using the desktop locale information.
<i>UniversalTime</i>	This variable inserts the current time converted to Coordinated Universal Time (UTC) format.
<i>Environment Variable</i>	<p>A variable with an additional parameter, which is an environment variable name. AutoText Plug-in retrieves the associated value of this variable and inserts the value in the AutoText entry. The variable name and environment variable name are separated by colon.</p> <p>Example: &lt;%Environment:USERNAME%&gt;.</p> <p>The system searches the USERNAME parameter in the system environment.</p>

---

## Creating a program

### About this task

You can create programs to perform the database-related activities.

#### Note:

You can create a separate program to route Microsoft Dynamics CRM activities to Call Center Elite Multichannel Desktop agents. You can also create a separate program for outbound calls.

### Procedure

1. Start Call Center Elite Multichannel Control Panel.
2. In the left pane, expand the **Database Management** node.

3. Expand the **Media Store Database** node.
4. Expand the database node for which you want to create a program.
5. Right-click the **Programs** node and click **Add Program**.
6. On the **Add Program** tab, enter appropriate values in the fields.
7. Right-click anywhere on the **Add Program** tab and click **Save And Close**.

**Related Links**

[Outbound programs for virtual agents](#) on page 215

## Add Program field descriptions



Name	Description
<b>Program</b>	
<b>Program ID</b>	A unique identifier for the program that you are currently creating.
<b>Name</b>	A common name for your program.
<b>Used by</b>	<p>The application that uses this program. For example, if you want Preview Contact Media Store to use this program, select the Preview Contact Media Store check box.</p> <p> <b>Note:</b></p> <p>If you create a new program for Preview Contact Media Store, the system displays the program in the <b>Interactions</b> list of Preview Contact Media Store, which connects to the same ASMediaStore database. From the Interactions list, you can assign a group of contacts to your program and save the contacts to the ASMediaStore Database. For more information, see <a href="#">Preview Contact Media Store</a> on page 83.</p>
<b>Description</b>	A brief description for your program.
<b>Prompt</b>	A welcome greeting that an agent use while contacting a customer.
<b>Service level seconds</b>	The service level time, in seconds, for the program created. Default is 0
<b>CC Elite Configuration tab - Program Configuration</b>	
<b>Auto Text list name</b>	An identifier for the AutoText group you want agents to view when the agents work on work items generated through this program.

*Table continues...*



Name	Description
<b>Canned Message list name</b>	A canned message group name from which you want to display the canned messages to customers.
<b>Program access mode</b>	A program is public that is, allowed or open, or private that is, denied or closed.
<b>CC Elite Configuration tab - Work Code</b>	
<b>Number of tab pages</b>	The number of tabs that you use for advanced work code. Default is 5.
<b>Minimum required work code(s)</b>	The minimum number of work codes that must be entered by the agent. Default is 1.
<b>Use Advanced Work Code style</b>	The check box to select advance work code style. The system disables the Standard work code list name field.
<b>Standard Work Code list name</b>	A name for the list of standard work codes that you have configured.
<b>Advanced Work Code list name</b>	The identifier of the AutoText group, in this case a group of work codes, that you want agents to view when agents work on work items generated through this program.
<b>Default work code</b>	The default work code. The default value is 0.
<b>CC Elite Configuration tab - Desktop Utility</b>	
<b>Automatically drop phantom call</b>	The check box to put an agent in the pending Auxiliary mode and drop the phantom call when the agent accepts a work item.
<b>Automatic drop reason code</b>	A reason code that the system uses when an agent enters in the Auxiliary mode. The default value is 0.
<b>Agent available on interaction close</b>	A condition based on which you want an agent to be available after the current interaction is closed.
<b>Auto accept non-voice interactions</b>	The check box to automatically accept all multimedia work items or interaction.
<b>CC Elite Configuration tab - Preview Contact Client</b>	
<b>Client action</b>	<p>An option that determines the behavior of Desktop when it receives a work item that the program you are configuring generates.</p> <ul style="list-style-type: none"> <li>• <b>0 - No action.</b> Call Center Elite Multichannel Desktop makes the contact information available to the agent. The agent initiates contact when ready.</li> <li>• <b>1 - Preview Contact.</b> Reserved for future use. If used, this option follows the behavior of 0 - No action.</li> <li>• <b>2 - Initiate Contact.</b> Desktop displays the contact information to an agent and automatically initiates</li> </ul>

*Table continues...*

Name	Description
	a call using the dial delay time specified in the <b>Auto dial delay (seconds)</b> parameter.
<b>Auto dial delay (seconds)</b>	The number of seconds Desktop waits after an agent receives a work item from a program. After the specified seconds, Desktop automatically dials a first number in the contact details. The default value is 20.
<b>Client window title</b>	The text that the system displays on the title bar of a Preview Contact work item window.
<b>CC Elite Outbound tab</b>	
<b>Available for outbound work</b>	An option that determines the state of an agent for an outbound work.
<b>Type of outbound work</b>	The type of an outbound work for an agent.
<b>Interaction ignored by AS client</b>	The check box to ignore the interactions of the current program.
<b>Associated program list</b>	A list of associated programs.
<b>Customized Configuration tab</b>	
<b>Key</b>	<p>The name of the associated data.</p> <p> <b>Note:</b></p> <p>This is the additional customer data that the system displays in a work item that agents receive.</p>
<b>Value</b>	<p>The value of the associated data.</p> <p> <b>Note:</b></p> <p>This is the additional customer data that the system displays in a work item that agents receive.</p>
<b>Topic</b>	<p>The optional topic to be used as a subgroup.</p> <p>This is the additional customer data that the system displays in a work item that agents receive.</p> <p> <b>Note:</b></p> <p>You can add the following key value pair that enables the system to correctly identify all <b>Microsoft Dynamics CRM</b> activities and route the activities to Call Center Elite Multichannel Desktop through the Microsoft Dynamics CRM GUI Plug-in.</p> <p><b>Key:</b> Work Item Type</p> <p><b>Value:</b> 100</p>

## Assigning a schedule to a program

### About this task

You can assign a schedule to a program to automatically run the program at a specified schedule. You can also assign more than one schedule to a single program.

After you assign a schedule to a program, the system automatically runs that program once, daily, or weekly. You can also specify time in a schedule.

### \* Note:

In Call Center Elite Multichannel, only one instance of a program schedule is active at a time. If the schedules of two programs overlap each other, the schedule that starts first takes the priority and the system ignores the other overlapping schedule.

### Procedure

1. Start Call Center Elite Multichannel Control Panel.
2. In the left pane, expand the **Database Management** node.
3. Expand the **Media Store Database** node.
4. Expand a specific database node.
5. Expand the **Programs** node.
6. Right-click a program node and click **Assign Schedule**.
7. On the **Assign Schedule** tab, enter appropriate values in the fields.
8. Right-click anywhere on the **Assign Schedule** tab and click **Save And Close**.

### Related Links

[Assign Schedule field descriptions](#) on page 114

## Assign Schedule field descriptions

Name	Description
<b>Schedule ID</b>	The field to select a schedule you want the program to use.  For more information about creating a schedule, see <a href="#">Creating a schedule</a> on page 105
<b>Resume type</b>	The field to select a behavior for the program when the program restarts at the selected schedule: <ul style="list-style-type: none"> <li>• <b>0-Resume:</b> The program restarts from the point where it stopped and stops when it is finished.</li> <li>• <b>1-Restart:</b> The program restarts from the beginning and stops when it is finished.</li> </ul>

*Table continues...*

Name	Description
	<ul style="list-style-type: none"> <li>• <b>2-Resume Restart:</b> The program restarts from the point it stopped, finishes, and restarts after it finishes.</li> </ul>
<b>Preview Contact Media Store</b>	
<b>Media director managed by control panel</b>	<p>Lists the media directors.</p> <p>Select the required media director to populate the drop-down list for Media director queue id.</p>
<b>Media director queue ID</b>	The Media Director queue ID for the Preview Contact work items.
<b>Queue priority</b>	The priority of queuing work items.

---

## Adding a queue to Media Director

### About this task

Using this procedure, you can add a queue to the Media Director configuration.

### Procedure

1. Start Call Center Elite Multichannel Control Panel.
2. In the left pane, expand the **Media Directors** node.
3. Expand the **Media Director** node.
4. Right-click the **Queues** node and click **Add Queue**.
5. On the **Add Queue** tab, enter appropriate values in the fields.
6. Right-click anywhere on the **Add Queue** tab and click **Save And Close**.
7. Right-click the node for a queue and click **Start Queue**.

### Related Links





[Add Queue field descriptions](#) on page 132

---



## Add Queue field descriptions

Name	Description
<b>Queue ID</b>	Unique identifier for a queue.

*Table continues...*

Name	Description
	<p> <b>Note:</b></p> <p>Do not include spaces between words. Use an underscore (_) to join words, for example, Queue_1</p>
<b>VDN</b>	<p>The Vector Director Number (VDN).</p> <p> <b>Note:</b></p> <p>A VDN must be unique for each queue.</p> <p>Communication Manager dials the VDN to add phantom calls to the skill queue. For example, VDN = 9830.</p> <p>Click the ellipses (...) button next to this field to select a VDN from the available VDNs in Communication Manager.</p>
<b>Phantom station DN list</b>	<p>In the <b>Phantom station DN list</b> field, you can enter a phantom station.</p> <p> <b>Note:</b></p> <p>Phantom station must be unique for each queue.</p> <p>You can enter multiple phantom stations by separating them with a comma. For example, 4500-4509,4510,4511. You can click the button next to this field to select phantom stations configured in Communication Manager.</p> <p>Communication Manager uses the specified phantom stations as originating points for the phantom calls, in a queue that you specify</p>
<b>Phantom call UUI</b>	<p>In the <b>Phantom call UUI</b> field, you can enter the text that Media Director displays to an agent when Media Director generates a phantom call.</p> <p>Default: PHANTOM_CALL. With the default value, the system informs an agent that the call is a phantom call</p>
<b>Maximum queued work items</b>	<p>The maximum number of work items that you want the system to keep waiting in a queue.</p> <p> <b>Important:</b></p> <p>If the maximum limit exceeds, Media Director returns an error to Media Store. If you set an invalid value, which is out of the 1 to 100 range or a fractional value, the system sets the default value to 100.</p>

*Table continues...*

Name	Description
	<p> <b>Note:</b></p> <p>To use the preferred agent functionality of Call Center Elite Multichannel, set the maximum limit to at least 100.</p>
<b>Maximum queued phantom calls</b>	<p>The maximum number of phantom calls that you want the system to keep in a VDN queue.</p> <p> <b>Important:</b></p> <p>If you set an invalid value, which is out of the 1 to 100 range or a fractional value, the system sets the default value to 100.</p>
<b>Dial phantom call when no clients</b>	The check box to generate phantom calls when there is no Desktop application connected to Media Director.
<b>Enable preferred agent</b>	<p>The check box to add work items to a queue of preferred agent that you set in a media store database.</p> <p>If you clear this check box, work items are added in the queue of an agent who logs into a skill.</p>
<b>Refuse work item when monitoring queue failed</b>	The check box to refuse the work items when monitoring queue fails.

## Configuring Email Media Store

### Before you begin

Ensure that you have installed Email Media Store. For instructions on how to install Email Media Store, see *Installing Avaya Aura® Call Center Elite Multichannel*.

 **Note:**

You must create separate queue in Email Media Store for every 1000 emails per hour. The maximum number of queues can be 25.

### About this task

Using this procedure, you can configure Email Media Store.

### Procedure

1. Start Call Center Elite Multichannel Control Panel.
2. In the left pane, expand the **Email Media Stores** node.
3. Right-click the **Email Media Store** node and click **Edit**.
4. On the **Edit Email Media Store** tab, enter appropriate values in the fields.

- Right-click anywhere on the **Edit Email Media Store** tab and click **Save And Close**.

## Edit Email Media Store field descriptions

Name	Description
<b>Media Director</b>	
<b>Media Director</b>	The Media Director server name.
<b>URL</b>	The URL that EMS uses to connect to the Media Director server.  The system forms this URL using the values that you specify in the IP, Port, Channel type, and URL fields.
<b>IP</b>	The IP address of Media Director.  The system automatically adds the IP address or host name of the Media Director server when you select a Media Director in the <b>Media Director</b> field.
<b>Port</b>	The port number to access the Media Director server. The default port number is 29087.
<b>Channel type</b>	The .Net remoting channel that the multimedia applications in Call Center Elite Multichannel use to communicate.  Default: gtcp.
<b>URI</b>	The Uniform Resource Identifier (URI) of the remote communication object factory on the Media Director server.  Default: RemoteFactory.rem.
<b>Error Logging</b>	In the <b>Error Logging</b> section, you can enter the field values as mentioned in <a href="#">Error Logging</a> on page 339.
<b>Media Store Database</b>	
<b>Server name</b>	The server name on which you have configured the media store database.
<b>Database name</b>	The database name that you have configured for EMS.
<b>User name</b>	The user name to access the selected database.
<b>Password</b>	The password to access the selected database.
<b>Connection string</b>	The connection string based on the server and database you select.
<b>Test Connection</b>	A button to test if you can connect to the selected database on the selected server.
<b>Contact Database</b>	

*Table continues...*

Name	Description
<b>Server name</b>	The name of a server on which you have configured the ASContact database.
<b>Database name</b>	The name of a database that you have configured for storing contacts.
<b>User name</b>	The user name to access the selected database.
<b>Password</b>	The password to access the selected database.
<b>Connection string</b>	The database connection string based on the server and database you select.
<b>Test Connection</b>	A button to test if you can connect to the selected database on the selected server.

---

## Adding a queue for Email Media Store

### About this task

Using this procedure, you can add a queue for Email Media Store.

### Procedure

1. Start Call Center Elite Multichannel Control Panel.
2. In the left pane, expand the **Email Media Stores** node.
3. Expand the **Email Media Store** node.
4. Right-click the **Queues** node and click **Add Queue**.
5. On the **Add Queue** tab, enter appropriate values in the fields on the following tabs:
  - **General**
  - **Inbound**
  - **Outbound**
  - **Auto Response**
  - **Components**
6. Right-click anywhere on the **Add Queue** tab and click **Save And Close**.
7. To save the changed settings in a configuration file, right-click the **Email Media Store** node and click **Commit Change**.
8. To start the newly added queue, right-click the queue and click **Start Queue**.

### Related Links

[Adding a rule](#) on page 81



## General field descriptions

Name	Description
<b>Email program ID</b>	The program ID of a program that you want this email queue to use.  EMS uses the program from the ASMediaStore database to which this EMS connects
<b>Media Director Queue</b>	
<b>Media Director queue ID for new email</b>	The queue ID of the Media Director queue that receives new email. The queue ID must match with one of the queue IDs that you set in the configuration of Media Director.  Click the field link to view the summary of the queues.
<b>Media Director queue ID for return email</b>	The queue ID of the Media Director queue that receives reply emails from customer. You can also use the queue ID of a queue that you have used for new email. The queue ID must match with one of the queue IDs that you set in the configuration of Media Director.  Click the field link to view the summary of the queues.
<b>Media Director queue priority for new email</b>	The priority with which new email conversations to this mailbox are queued in the Media Director. Because the Media Director creates priority lists from objects created by all types of media stores, this number must be set by someone who has an overview of all media stores and the level of importance of all operating mailboxes. The priority number range does not have any limit. You can use priority number range of 1-10 with 1 being the highest. This priority is overridden for customers listed in the Priority Contact table of the database.
<b>Media Directory queue priority for return email</b>	The priority with which returning emails to this mailbox are queued in the Media Director. This priority is overridden for customers listed in the Priority Contact table.
<b>Media Director maximum queued items</b>	The maximum number of email work items that can be queued to the Media Director from this queue. Downloaded mails remains unprocessed by the media store to prevent this number from being exceeded.
<b>Email Storage</b>	

*Table continues...*

Name	Description
<b>Email storage path</b>	The path EMS uses when it saves email files. If this parameter is blank, the files are stored in the current working directory under a folder named after the queue identifier.
<b>Email storage type</b>	<p>A value that controls how email files are organized when they are stored.</p> <p>Valid values are:</p> <ul style="list-style-type: none"> <li>• Flat that is, the email files are stored in the Email storage path without any substructure.</li> <li>• Daily that is, the email files are stored in the subfolder of the Email storage path, which is created for each day named in the format of “yyyymmdd”.</li> <li>• Weekly that is, the email files are stored in the subfolder of the Email storage path, which is created for each week named in the format of “yyyy” plus letter “w” in the middle and “mmdd” of the Monday of this week at the end.</li> <li>• Monthly that is, the email files are stored in the subfolder of the Email storage path, which is created for each month named in the format of “yyyymm”.</li> </ul>
<b>Notification Email Address</b>	
<b>Administrator email address</b>	The email address for the administrator of this queue. The administrator is notified of any email or system problems.
<b>Suspended email notification list</b>	A comma-separated list of email addresses which belongs to supervisors that receives notification when a work item is suspended.
<b>Client Side Agent Desktop Preference</b>	
<b>Disable agent blind copy</b>	The check box to restrict agents entering address in the <b>Bcc</b> field of an email that the agents are replying or forwarding.
<b>Include original email when replying</b>	The check box to help the media store to include the content of an original email to an email that an agent is replying.
<b>Allow agent editing original email</b>	<p>With this check box, the agents can edit the original email when replying to an email. The system displays the original email in the editable form.</p> <p>If you clear this check box, the system splits the reply email window with the reply email at the upper</p>

*Table continues...*

Name	Description
	side, and the original email at the lower side in a non-editable form.  This parameter works only when you select the <b>Include original email when replying</b> check box.
<b>Limit agent response to sender</b>	The check box to restrict agents to edit the email addresses when replying to an email.
<b>Allow agent changing the default RE reply email receiver</b>	With this check box, the agents can change the default setting of the <b>Reply Directly To Customer</b> check box in an email work item, which is forwarded to a resident expert.  By default, the <b>RE reply to customer by default</b> check box on the <b>Components</b> tab controls the settings of this check box.
<b>Force agent to close with completed success</b>	The check box to restrict agents for closing the email work item without providing the completion status. This also removes the close button from the email work item tab.
<b>Disable agent save email</b>	The check box to disable agents from saving the emails.
<b>Signature</b>	Text that is automatically added to the bottom of any email the user replies to or forwards.

---

## Inbound field descriptions

Name	Description
<b>POP3 Server</b>	
<b>POP3 server name</b>	The name or IP address of the email server that provide inbound POP3 services. You must enter the POP3 server name to help agents to receive emails.
<b>POP3 user name</b>	The user name required for POP3 authentication with the mail server. This parameter represents the POP3 mailbox and cannot be blank.
<b>POP3 password</b>	The password associated with the POP3 user name. You must enter the password to help agents to receive emails.  By default, Call Center Elite Multichannel encrypts this data. For more information, see <i>Installing Avaya Aura® Call Center Elite Multichannel</i> .
<b>POP3 server port</b>	The port number of the mail server that offers inbound POP3 services.

*Table continues...*

Name	Description
<b>POP3 timeout</b>	The time, in milliseconds, EMS waits for a response from the POP3 server after connected. The default value is 3000 (3 seconds). If EMS fails to receive a response within the specified time, the media store sends a Major-level error to the error log and attempts to close the connection to the POP3 server by sending a QUIT command. If the quit request also times out, it takes double than the time specified in the POP3 timeout parameter for the connection to the POP3 server to be dropped.
<b>Enable POP3 trace</b>	<p>With this setting, you can log details about POP3 transactions and diagnose email download problems.</p> <p>If you enable POP3 tracing, the log file reaches the maximum size more fast, and the performance of the EMS can be affected.</p>
<b>Download</b>	
<b>Mailbox check interval</b>	The time interval, in seconds, between attempts to connect to the specified mail server and retrieve new mail items. This value has a lower limit of 10. If this value is not present, a default of 60 is used. This parameter works in conjunction with Maximum emails downloaded per polling to control the number of queued emails.
<b>Maximum emails downloaded per polling</b>	The maximum number of mail items that can be downloaded during one poll of the mail server. This parameter works in conjunction with Mailbox check interval to control the number of queued emails.
<b>Maximum emails pending processing</b>	The maximum number of unprocessed email conversations that can be in this queue. If this number exceeds, the media store temporarily stops polling the mail server. When the number drops below the threshold, polling restarts. If one EMS is set up in your contact center environment, you must use the default value-0 (infinity). The meaning of one EMS set up is a single queue is receiving email for a single email address. The preferred method of controlling the number of queued emails is through the Maximum emails downloaded for each polling and Mailbox check interval parameters.
<b>Temporary download path</b>	The directory in which emails are downloaded from the mail server is stored until preprocessed. If you specify only a folder name, it is saved in the installation folder of the application.

*Table continues...*

Name	Description
<b>Automatically create download path</b>	The check box to create download path for the emails.  If you do not specify a directory in the Temporary download path parameter, the system creates a directory in the installation folder of Call Center Elite Multichannel Control Panel, in the TempDownload_QueueName format.
<b>Poll email when queue closed</b>	The check box to enable EMS to connect the mail server and download new email items that arrives in a queue after the queue closes.

## Outbound field descriptions

Name	Description
<b>SMTP Server</b>	
<b>Email address</b>	The email address for this mailbox. This address can reference an individual, a department, or signal a particular work-related purpose. The email address displays in the From field with any outgoing email.
<b>Reply email address</b>	The reply email address of a customer for this queue.  The system displays this address to a customer in the <b>To</b> field when the customer chooses to reply to an agent for an email that was replied to the customer.  This address can be different from the address used by the customer to initiate contact in the first email. If you leave this parameter blank, the system uses the reply email address of a customer as the reply email address for this mailbox.
<b>SMTP server name</b>	The name or IP address of the mail server that offers outbound SMTP services. You must enter the SMTP server name to help agents to send or reply emails. If you do not set the SMTP server name, the customer cannot receive any autoresponses or emails from agents. But, if you set the SMTP server name later, the system sends these autoresponses and emails to respective customers.
<b>SMTP user name</b>	The user name required for SMTP authentication with the mail server.
<b>SMTP password</b>	The password associated with the SMTP user name. By default, the Call Center Elite Multichannel

*Table continues...*

Name	Description
	application encrypts this data. For more information about configuration commands, see <i>Installing Avaya Aura® Call Center Elite Multichannel</i> .
<b>SMTP server port</b>	The port number of the mail server that offers outbound SMTP services.
<b>SMTP timeout</b>	The length of time, in milliseconds, EMS waits for a response from the SMTP mail server after connected. The default value is 3000 (3 seconds). If the EMS fails to receive a response within the specified time, the media store sends a Major-level error to the error log and attempts to close the connection to the mail server by sending a QUIT command. If the quit request also times out, it takes double than the time specified in the SMTP time-out parameter for the connection to the mail server to be dropped.
<b>Enable SMTP trace</b>	With this setting, you can log details about SMTP transactions and diagnose email sending problems.  If you enable SMTP tracing, the log file reaches the maximum size more quickly, and the performance of the EMS can affect.
<b>Postprocessing</b>	
<b>Email aliases for replying all</b>	A comma-separated list of email addresses that deliver email to the queue, and which is removed from any address fields (To, Cc, or Bcc) when sending a Reply To All response. You do not need to include the email address defined in the email address parameter of the queue.

---

## Auto Response field descriptions

Name	Description
<b>Closed Sender Group Auto Response</b>	
<b>Auto response file</b>	The name of the text file that contains the body of an email that is automatically sent if this queue is marked as a closed sender group (see the Closed sender group parameter) and a new email is received from a user or domain not in the Allowed Sender Table.  If the option to use default auto response template files was selected during installation, the file name

*Table continues...*

Name	Description
	<p>ClosedSender.txt appears. EMS automatically searches for the auto response file in</p> <pre data-bbox="841 331 1430 457">\Avaya Aura® CC Elite Multichannel\Server \Media Store\Email\Application\Email Auto Responses .</pre> <p>If you want to change the location, specify the full file path along with the auto response file name. For example, I:\Email Media Store\Email Auto Responses\ClosedSenderGroup.txt.</p> <p>To ensure all language character sets display properly, the .txt file should be saved with Unicode encoding. If the file is saved with ANSI coding, EMS must run in the locale of the language used.</p>
<b>Auto response character set</b>	The character set used for the body of the auto response message. The default is empty, which means the system uses the default encoding. This is generally <b>iso-8859-1</b> .
<b>Auto response subject</b>	The text that appears in the Subject line of the auto response message. The default is “Your email '{0}' is rejected”, where {0} is the subject of the inbound email being responded to.
<b>Auto response attachments</b>	A comma-separated list of files that is attached to the email that is sent when a new email is received from a user or domain not in the Allowed Sender Table when this queue is marked as a closed sender group.
<b>Denied Sender Auto Response</b>	
<b>Auto response file</b>	<p>The name of the text file that contains the body of an email that is automatically sent when a new email is received from a user or domain in the Denied Sender Table. This email is only sent if the EDLNotify parameter is activated against the user in the Denied Sender Table.</p> <p>If the option to use default auto response template files was selected during installation, the file name Denied.txt appears. EMS automatically searches for the auto response file in</p> <pre data-bbox="841 1633 1430 1759">\Avaya Aura® CC Elite Multichannel\Server \Media Store\Email\Application\Email Auto Responses .</pre>

*Table continues...*

Name	Description
	<p>If you want to change the location, specify the full file path along with the auto response file name. For example, I:\Email Media Store\Email Auto Responses\DeniedSender.txt.</p> <p>To ensure all language character sets display properly, the .txt file should be saved with Unicode encoding. If the file is saved with ANSI coding, EMS must run in the locale of the language used.</p>
<b>Auto response character set</b>	<p>The character set used for the body of the auto response message. The default is empty, which means the system uses the default encoding. This is generally <b>iso-8859-1</b>.</p>
<b>Auto response subject</b>	<p>The text that appears in the Subject line of the auto response message. The default is “Your email '{0}' is rejected”, where {0} is the subject of the inbound email being responded to.</p>
<b>Auto response attachments</b>	<p>A comma-separated list of files that is attached to the email that is sent when a new email is received from a user or domain on the Denied Sender Table.</p>
<b>In Hours Auto Response</b>	
<b>Auto response file</b>	<p>The name of the text file that contains the body of an email that is automatically sent when a new email is received within the operating hours of a queue. The text file should confirm that the email has been received and will be responded to shortly. Emails that are part of an existing email conversation do not generate this auto response. If the option to use default auto response template files was selected during installation, the file name InHours.txt appears. EMS automatically searches for the auto response file in</p> <p style="margin-left: 20px;">\Avaya Aura® CC Elite Multichannel\Server\Media Store\Email\Application\Email Auto Responses</p> <p>. If you want to change the location, specify the full file path along with the auto response file name. For example, I:\Email Media Store\Email Auto Responses\DuringOperatingHours.txt.</p> <p>To ensure all language character sets display properly, the .txt file should be saved with Unicode encoding. If the file is saved with ANSI coding, Email Media Store must run in the locale of the language used.</p>

*Table continues...*



Name	Description
<b>Auto response character set</b>	The character set used for the body of the auto response message. The default is empty, which means the system uses the default encoding. This is generally <b>iso-8859-1</b> .
<b>Auto response subject</b>	The text that appears in the Subject line of the auto response message. The default is “Your email '{0}' is rejected”, where {0} is the subject of the inbound email being responded to.
<b>Auto response attachments</b>	A comma-separated list of files that is attached to the email that is sent when a new email is received inside normal working hours.
<b>Out of Hours Auto Response</b>	
<b>Auto response file</b>	<p>The name of the text file that contains the body of an email that is automatically sent when a new email is received outside the queue's operating hours. This text could confirm that the email has been received and will be responded to the next day. Emails that are part of an existing email conversation do not generate this auto response. If the option to use default auto response template files was selected during installation, the file name OutHours.txt appears. EMS automatically searches for the auto response file in</p> <pre data-bbox="841 1056 1325 1083">\Avaya Aura® CC Elite Multichannel</pre> <p>\Server\Media Store\Email\Application\Email Auto Responses. If you want to change the location, specify the full file path along with the auto response file name. For example, I:\Email Media Store\Email Auto Responses\OutsideOperatingHours.txt.</p> <p>To ensure all language character sets display properly, the .txt file should be saved with Unicode encoding. If the file is saved with ANSI coding, EMS must run in the locale of the language used.</p>
<b>Auto response character set</b>	The character set used for the body of the auto response message. The default is empty, which means the system uses the default encoding. This is generally <b>iso-8859-1</b> .
<b>Auto response subject</b>	The text that appears in the Subject line of the auto response message. The default is “Your email '{0}' was accepted”, where {0} is the subject of the inbound email being responded to.

*Table continues...*

Name	Description
<b>Auto response attachments</b>	A comma-separated list of files that is attached to the email that is sent when a new email is received outside normal working hours.

## Components field descriptions

Name	Description
<b>Preprocessing Components</b>	<p>In the <b>Preprocessing Components</b> section, you can select the required preprocessing components by clicking the corresponding check boxes.</p> <p>You must set the additional fields for the following components:</p> <ul style="list-style-type: none"> <li>• <b>Resident Expert Response Pre-processor.</b> For more information, see <a href="#">Setting the Resident Expert Response pre-processor</a> on page 77.</li> <li>• <b>Keyword Based Routing pre-processor.</b> For more information, see <a href="#">Setting the Keyword Based Routing pre-processor</a> on page 79.</li> </ul>
<b>Postprocessing Components</b>	In the <b>Postprocessing Components</b> section, you can select the required postprocessing components by clicking the corresponding check boxes.
<b>Automatic Bcc Post-Processor</b>	<p>You can click the <b>Automatic Bcc Post-Processor</b> field in the <b>Postprocessing Components</b> section and specify the following:</p> <ul style="list-style-type: none"> <li>• <b>Queue automatic blind copy addresses.</b> Queue automatic blind copy addresses is a comma-separated list of addresses that is always sent as a Bcc copy on reply emails from this queue.</li> </ul>
<b>Auto Footer Text Post-Processor</b>	<p>You can click the <b>Auto Footer Text Post-Processor</b> field in the <b>Postprocessing Components</b> section and specify the following:</p> <ul style="list-style-type: none"> <li>• <b>Auto footer text file name.</b> The name of the file that contains the text that appears at the bottom of every text email that an agent sends. If the option to use default auto response template files was selected during installation, the file name <code>AutoFooter.txt</code> appears. EMS automatically searches for the auto response file in</li> </ul> <pre>\Avaya Aura® CC Elite Multichannel\Server \Media Store\Email\Application\Email Auto Responses</pre>

*Table continues...*

Name	Description
	<p>. To change the location, specify the full file path along with the auto response file name. For example, I:\Email Media Store\Email Auto Responses\AutoFooter.txt. To ensure all language character sets display properly, save the .txt file with Unicode encoding. If the file is saved with ANSI coding, EMS must run in the locale of the language used.</p> <ul style="list-style-type: none"> <li>• <b>Auto footer HTML file name.</b> The name of the file that contains the text that appears at the bottom of every HTML email that an agent sends. If the option to use default auto response template files was selected during installation, the file name AutoFooter.txt appears. EMS automatically searches for the auto response file in   \Avaya Aura® CC Elite Multichannel   \Server\Media Store\Email\Application\Email Auto Responses. To change the location, specify the full file path along with the auto response file name. For example, I:\Email Media Store\Email Auto Responses\AutoFooter.txt.</li> <li>• <b>Auto footer character set.</b> The character set which encodes the auto-footer message. The default is the default encoding of the server.</li> </ul>

# Chapter 8: Configuring Simple Messaging Media Store channel

---

## Prerequisites for configuring Simple Messaging Media Store channel

The following are the prerequisites for configuring Simple Messaging Media Store channel:

- Call Center Elite Multichannel core services must be installed and running.
- Simple Messaging Media Store must be installed and running.
- The respective media gateways must be configured and accessible.

---

## Checklist for configuring Simple Messaging Media Store channel

The following checklist outlines the series of steps you must take to configure Simple Messaging Media Store channel.

Step	Task	✓
1	Create a schedule in Media Store Database	
2	(Optional) Create an AutoText group/Work Code	
3	Create a program in Media Store Database	
4	Assign a schedule to a program in Media Store Database	
5	Create a Simple Messaging Media Store queue in Media Director	
6	Configure Simple Messaging Media Store	
7	Add a queue for Simple Messaging Media Store	
8	Configure Simple Messaging Media Store gateways	

## Creating a schedule

### About this task

You can create and assign a schedule to a program. The system automatically executes the program at the scheduled date and time. You can create a schedule that runs daily or weekly or a schedule that runs only once.

You can also select the work type in a schedule. The work type determines if the system runs the schedule on a working day or on a holiday.

### Procedure

1. Start Call Center Elite Multichannel Control Panel.
2. In the left pane, expand the **Database Management** node.
3. Expand the **Media Store Database** node.
4. Expand a specific database node.
5. Right-click **Schedules** and click **Add Schedule**.
6. On the **Add Schedule** tab, enter appropriate values in the fields.
7. Right-click anywhere on the **Add Schedule** tab and click **Save And Close**.

## Add Schedule field descriptions

Name	Description
<b>Schedule</b>	
<b>Name</b>	The name for the new schedule
<b>Work type</b>	The type of work that you want to schedule. 0- Normal 1- Holiday
<b>Schedule Time</b>	
<b>Start</b>	The starting time of a schedule.
<b>End</b>	The ending time of a schedule.
<b>Duration</b>	The duration of the schedule.
<b>Schedule Type</b>	The type of schedule you want to run. The types of schedules you can run are: <ul style="list-style-type: none"> <li>• One off</li> <li>• Daily</li> <li>• Weekly</li> </ul>

*Table continues...*

Name	Description
Schedule Date	
Start	The start date of a schedule.
End	The end date of a schedule.

---

## Creating an AutoText group/Work Code

### About this task

You can create different AutoText groups to categorize different AutoText entries that agents can use when processing work items. This action helps the agents to find the required AutoText entry from the application menu bar.

### Procedure

1. Start Call Center Elite Multichannel Control Panel.
2. In the left pane, expand the **Database Management** node.
3. Expand the **Media Store Database** node.
4. Expand a specific database node where you want to create the AutoText group.
5. Right-click the **AutoText/Work Code** node and click **Add AutoText Group**.
6. On the **Add AutoText** tab, in the **AutoText group name** field, enter a name for the AutoText group.
7. Right-click anywhere on the **Add AutoText** tab and click **Save And Close**.

---

## Adding AutoText entries in an AutoText group

### About this task

When an agent selects an AutoText menu from Call Center Elite Multichannel Desktop, the AutoText plug-in scans the value of a selected AutoText for variables and replaces the variables with the correct value. The AutoText plug-in replaces the unknown or missing variables with a space or empty string.

### Procedure

1. Start Call Center Elite Multichannel Control Panel.
2. In the left pane, expand the **Database Management** node.
3. Expand the **Media Store Database** node.
4. Expand a specific database node.
5. Expand the **AutoText/Work Code** node.

6. Right-click an AutoText group name and click **Manage AutoText Items**.
7. On the **Manage AutoTexts** tab, enter appropriate values in the following fields:
  - Topic
  - Key
  - Values
8. Right-click anywhere on the **Manage AutoTexts** tab and click **Save And Close**.

**\* Note:**

For a unique topic name, you can have multiple topics with the same key within a particular group. Similarly, for a unique key, you can have multiple keys with the same topic.

You can copy and paste data from one AutoText group to another AutoText group, double-click a cell to edit the value of an AutoText entry, and right-click a cell and select an option to insert a predefined variable into the value of an AutoText entry.

### Related Links

[Manage AutoTexts field descriptions](#) on page 108

[Supported variables in the AutoText Plug-in](#) on page 108

## Manage AutoTexts field descriptions

Name	Description
<b>Topic</b>	This is the name of a group of the related AutoText entries or work codes. For example, Membership.
<b>Key</b>	This is the name of the AutoText or work code. For example, Join.
<b>Value</b>	This is the text that the system displays when an agent selects an AutoText key. For work codes, the value is a number. For example, 11.

## Supported variables in the AutoText Plug-in

You can use the following variables in the AutoText Plug-in.

Name	Description
<i>StationDN</i>	The station number of the agent using Call Center Elite Multichannel Desktop.

*Table continues...*

Name	Description
<i>StationName</i>	The name configured in Communication Manager for the station of an agent using Call Center Elite Multichannel Desktop.
<i>AgentID</i>	The agent ID of an agent who is logged in to the station using Call Center Elite Multichannel Desktop. If no agent is logged in, the system displays this variable as blank.
<i>AgentName</i>	The name configured in Communication Manager for an agent who is logged in to the station using Call Center Elite Multichannel Desktop.  If no agent is logged in, this variable shows a blank value.
<i>LoggedInUser</i>	The user name of a person logged in to a system that runs Call Center Elite Multichannel Desktop.
<i>MachineName</i>	The name of a system that is running Call Center Elite Multichannel Desktop.
<i>InteractionData</i>	<p>A variable with additional parameters that specifies a topic and a key for data. This data is held in the extra data table associated with the currently selected work item.</p> <p>In this variable, the topic parameter is optional. The topic and key parameters are separated by colon. If the key contains a single character, such as asterisks (*), all values that matches with the specified topic are inserted.</p> <p>For example: &lt;%InteractionData:SMMS:Message %&gt;.</p> <p>In this example, the system processes the queue configuration data associated with a current work item, locates the SMMS topic and a Message key, and inserts the contents of the value into this variable.</p>
<i>ProgramData</i>	<p>A variable with additional parameters that specify a topic and a key for data. This data is part of the queue configuration data associated with a currently selected work item.</p> <p>In this variable, the topic parameter is optional. The topic and key parameters are separated by colon. If the key contains a single character, such as asterisk (*), all values that matches with the specified topic are inserted.</p>

*Table continues...*



Name	Description
	<p>This functionality of this variable is identical to the <b>InteractionData</b> variable, but with a different source of information.</p> <p>For example: &lt;%ProgramData:SMMS:Message%&gt;.</p> <p>In this example, the system processes the queue configuration data associated with a current work item, locates the SMMS topic and a Message key, and inserts the contents of the value into this variable.</p>
<i>Break</i>	This variable inserts a carriage return line-feed combination into the text at the specified point.
<i>LongDate</i>	This variable inserts the current date in the Long format. The date is formatted using the desktop locale information.
<i>ShortDate</i>	This variable inserts the current date in the Short format. The date is formatted using the desktop locale information.
<i>LongTime</i>	This variable inserts the current time in the Long format. The time is formatted using the desktop locale information.
<i>ShortTime</i>	This variable inserts the current time in the Short format. The time is formatted using the desktop locale information.
<i>UniversalTime</i>	This variable inserts the current time converted to Coordinated Universal Time (UTC) format.
<i>Environment Variable</i>	<p>A variable with an additional parameter, which is an environment variable name. AutoText Plug-in retrieves the associated value of this variable and inserts the value in the AutoText entry. The variable name and environment variable name are separated by colon.</p> <p>Example: &lt;%Environment:USERNAME%&gt;.</p> <p>The system searches the USERNAME parameter in the system environment.</p>

---

## Creating a program

### About this task

You can create programs to perform the database-related activities.

**\* Note:**

You can create a separate program to route Microsoft Dynamics CRM activities to Call Center Elite Multichannel Desktop agents. You can also create a separate program for outbound calls.

**Procedure**

1. Start Call Center Elite Multichannel Control Panel.
2. In the left pane, expand the **Database Management** node.
3. Expand the **Media Store Database** node.
4. Expand the database node for which you want to create a program.
5. Right-click the **Programs** node and click **Add Program**.
6. On the **Add Program** tab, enter appropriate values in the fields.
7. Right-click anywhere on the **Add Program** tab and click **Save And Close**.

**Related Links**

[Outbound programs for virtual agents](#) on page 215



## Add Program field descriptions

Name	Description
<b>Program</b>	
<b>Program ID</b>	A unique identifier for the program that you are currently creating.
<b>Name</b>	A common name for your program.
<b>Used by</b>	<p>The application that uses this program. For example, if you want Preview Contact Media Store to use this program, select the Preview Contact Media Store check box.</p> <p><b>* Note:</b></p> <p>If you create a new program for Preview Contact Media Store, the system displays the program in the <b>Interactions</b> list of Preview Contact Media Store, which connects to the same ASMediaStore database. From the Interactions list, you can assign a group of contacts to your program and save the contacts to the ASMediaStore Database. For more information, see <a href="#">Preview Contact Media Store</a> on page 83.</p>
<b>Description</b>	A brief description for your program.

*Table continues...*

Name	Description
<b>Prompt</b>	A welcome greeting that an agent use while contacting a customer.
<b>Service level seconds</b>	The service level time, in seconds, for the program created. Default is 0
<b>CC Elite Configuration tab - Program Configuration</b>	
<b>Auto Text list name</b>	An identifier for the AutoText group you want agents to view when the agents work on work items generated through this program.
<b>Canned Message list name</b>	A canned message group name from which you want to display the canned messages to customers.
<b>Program access mode</b>	A program is public that is, allowed or open, or private that is, denied or closed.
<b>CC Elite Configuration tab - Work Code</b>	
<b>Number of tab pages</b>	The number of tabs that you use for advanced work code. Default is 5.
<b>Minimum required work code(s)</b>	The minimum number of work codes that must be entered by the agent. Default is 1.
<b>Use Advanced Work Code style</b>	The check box to select advance work code style. The system disables the Standard work code list name field.
<b>Standard Work Code list name</b>	A name for the list of standard work codes that you have configured.
<b>Advanced Work Code list name</b>	The identifier of the AutoText group, in this case a group of work codes, that you want agents to view when agents work on work items generated through this program.
<b>Default work code</b>	The default work code. The default value is 0.
<b>CC Elite Configuration tab - Desktop Utility</b>	
<b>Automatically drop phantom call</b>	The check box to put an agent in the pending Auxiliary mode and drop the phantom call when the agent accepts a work item.
<b>Automatic drop reason code</b>	A reason code that the system uses when an agent enters in the Auxiliary mode. The default value is 0.
<b>Agent available on interaction close</b>	A condition based on which you want an agent to be available after the current interaction is closed.
<b>Auto accept non-voice interactions</b>	The check box to automatically accept all multimedia work items or interaction.
<b>CC Elite Configuration tab - Preview Contact Client</b>	

*Table continues...*

Name	Description
<b>Client action</b>	<p>An option that determines the behavior of Desktop when it receives a work item that the program you are configuring generates.</p> <ul style="list-style-type: none"> <li>• <b>0 - No action.</b> Call Center Elite Multichannel Desktop makes the contact information available to the agent. The agent initiates contact when ready.</li> <li>• <b>1 - Preview Contact.</b> Reserved for future use. If used, this option follows the behavior of 0 - No action.</li> <li>• <b>2 - Initiate Contact.</b> Desktop displays the contact information to an agent and automatically initiates a call using the dial delay time specified in the <b>Auto dial delay (seconds)</b> parameter.</li> </ul>
<b>Auto dial delay (seconds)</b>	<p>The number of seconds Desktop waits after an agent receives a work item from a program. After the specified seconds, Desktop automatically dials a first number in the contact details. The default value is 20.</p>
<b>Client window title</b>	<p>The text that the system displays on the title bar of a Preview Contact work item window.</p>
<b>CC Elite Outbound tab</b>	
<b>Available for outbound work</b>	<p>An option that determines the state of an agent for an outbound work.</p>
<b>Type of outbound work</b>	<p>The type of an outbound work for an agent.</p>
<b>Interaction ignored by AS client</b>	<p>The check box to ignore the interactions of the current program.</p>
<b>Associated program list</b>	<p>A list of associated programs.</p>
<b>Customized Configuration tab</b>	
<b>Key</b>	<p>The name of the associated data.</p> <p> <b>Note:</b> This is the additional customer data that the system displays in a work item that agents receive.</p>
<b>Value</b>	<p>The value of the associated data.</p> <p> <b>Note:</b> This is the additional customer data that the system displays in a work item that agents receive.</p>
<b>Topic</b>	<p>The optional topic to be used as a subgroup.</p>

*Table continues...*

Name	Description
	<p>This is the additional customer data that the system displays in a work item that agents receive.</p> <p> <b>Note:</b></p> <p>You can add the following key value pair that enables the system to correctly identify all <b>Microsoft Dynamics CRM</b> activities and route the activities to Call Center Elite Multichannel Desktop through the Microsoft Dynamics CRM GUI Plug-in.</p> <p><b>Key:</b> Work Item Type</p> <p><b>Value:</b> 100</p>

## Assigning a schedule to a program

### About this task

You can assign a schedule to a program to automatically run the program at a specified schedule. You can also assign more than one schedule to a single program.

After you assign a schedule to a program, the system automatically runs that program once, daily, or weekly. You can also specify time in a schedule.

### Note:

In Call Center Elite Multichannel, only one instance of a program schedule is active at a time. If the schedules of two programs overlap each other, the schedule that starts first takes the priority and the system ignores the other overlapping schedule.

### Procedure

1. Start Call Center Elite Multichannel Control Panel.
2. In the left pane, expand the **Database Management** node.
3. Expand the **Media Store Database** node.
4. Expand a specific database node.
5. Expand the **Programs** node.
6. Right-click a program node and click **Assign Schedule**.
7. On the **Assign Schedule** tab, enter appropriate values in the fields.
8. Right-click anywhere on the **Assign Schedule** tab and click **Save And Close**.

### Related Links

[Assign Schedule field descriptions](#) on page 114

## Assign Schedule field descriptions

Name	Description
<b>Schedule ID</b>	The field to select a schedule you want the program to use.  For more information about creating a schedule, see <a href="#">Creating a schedule</a> on page 105
<b>Resume type</b>	The field to select a behavior for the program when the program restarts at the selected schedule: <ul style="list-style-type: none"> <li>• <b>0-Resume</b>: The program restarts from the point where it stopped and stops when it is finished.</li> <li>• <b>1-Restart</b>: The program restarts from the beginning and stops when it is finished.</li> <li>• <b>2-Resume Restart</b>: The program restarts from the point it stopped, finishes, and restarts after it finishes.</li> </ul>
<b>Preview Contact Media Store</b>	
<b>Media director managed by control panel</b>	Lists the media directors.  Select the required media director to populate the drop-down list for Media director queue id.
<b>Media director queue ID</b>	The Media Director queue ID for the Preview Contact work items.
<b>Queue priority</b>	The priority of queuing work items.

## Adding a queue to Media Director

### About this task

Using this procedure, you can add a queue to the Media Director configuration.

### Procedure



1. Start Call Center Elite Multichannel Control Panel.
2. In the left pane, expand the **Media Directors** node.
3. Expand the **Media Director** node.
4. Right-click the **Queues** node and click **Add Queue**.
5. On the **Add Queue** tab, enter appropriate values in the fields.
6. Right-click anywhere on the **Add Queue** tab and click **Save And Close**.

7. Right-click the node for a queue and click **Start Queue**.



### Related Links

[Add Queue field descriptions](#) on page 132

## Add Queue field descriptions

Name	Description
<b>Queue ID</b>	Unique identifier for a queue.   <b>Note:</b> Do not include spaces between words. Use an underscore (_) to join words, for example, Queue_1
<b>VDN</b>	The Vector Director Number (VDN).   <b>Note:</b> A VDN must be unique for each queue.  Communication Manager dials the VDN to add phantom calls to the skill queue. For example, VDN = 9830.  Click the ellipses (...) button next to this field to select a VDN from the available VDNs in Communication Manager.
<b>Phantom station DN list</b>	In the <b>Phantom station DN list</b> field, you can enter a phantom station.   <b>Note:</b> Phantom station must be unique for each queue.  You can enter multiple phantom stations by separating them with a comma. For example, 4500-4509,4510,4511. You can click the button next to this field to select phantom stations configured in Communication Manager.  Communication Manager uses the specified phantom stations as originating points for the phantom calls, in a queue that you specify
<b>Phantom call UUI</b>	In the <b>Phantom call UUI</b> field, you can enter the text that Media Director displays to an agent when Media Director generates a phantom call.

*Table continues...*

Name	Description
	Default: PHANTOM_CALL. With the default value, the system informs an agent that the call is a phantom call
<b>Maximum queued work items</b>	<p>The maximum number of work items that you want the system to keep waiting in a queue.</p> <p> <b>Important:</b></p> <p>If the maximum limit exceeds, Media Director returns an error to Media Store. If you set an invalid value, which is out of the 1 to 100 range or a fractional value, the system sets the default value to 100.</p> <p> <b>Note:</b></p> <p>To use the preferred agent functionality of Call Center Elite Multichannel, set the maximum limit to at least 100.</p>
<b>Maximum queued phantom calls</b>	<p>The maximum number of phantom calls that you want the system to keep in a VDN queue.</p> <p> <b>Important:</b></p> <p>If you set an invalid value, which is out of the 1 to 100 range or a fractional value, the system sets the default value to 100.</p>
<b>Dial phantom call when no clients</b>	The check box to generate phantom calls when there is no Desktop application connected to Media Director.
<b>Enable preferred agent</b>	<p>The check box to add work items to a queue of preferred agent that you set in a media store database.</p> <p>If you clear this check box, work items are added in the queue of an agent who logs into a skill.</p>
<b>Refuse work item when monitoring queue failed</b>	The check box to refuse the work items when monitoring queue fails.

## Configuring Simple Messaging Media Store

### Before you begin

Ensure that you have installed Simple Messaging Media Store. For instructions on how to install Simple Messaging Media Store, see *Installing Avaya Aura® Call Center Elite Multichannel*.

### Procedure

1. Start Call Center Elite Multichannel Control Panel.



2. In the left pane, expand the **Simple Messaging Media Stores** node.
3. Right-click the **Simple Messaging Media Store** node and click **Edit**.
4. On the **Edit SMMS Details** tab, enter appropriate values in the fields.
5. Right-click anywhere on the **Edit SMMS Details** tab and click **Save And Close**.

## Edit SMMS Details field descriptions

Name	Description
<b>Media Director</b>	
<b>Media Director</b>	The Media Director server name.
<b>URL</b>	The URL that SMMS uses to connect to the Media Director server.  The system forms this URL using the values that you specify in the IP, Port, Channel type, and URL fields.
<b>IP</b>	The IP address of Media Director.  The system automatically adds the IP address or host name of the Media Director server when you select a Media Director in the <b>Media Director</b> field.
<b>Port</b>	The port number to access the Media Director server. The default port number is 29087.
<b>Channel type</b>	The .Net remoting channel that the multimedia applications in Call Center Elite Multichannel use to communicate.  Default: gtcp.
<b>URI</b>	The Uniform Resource Identifier (URI) of the remote communication object factory on the Media Director server.  Default: RemoteFactory.rem.
<b>Error Logging</b>	You can enter the field values as mentioned in <a href="#">Error Logging</a> on page 339.
<b>Media Store Database</b>	
<b>Server name</b>	The server name on which you have configured the media store database.
<b>Database name</b>	The database name that you have configured for EMS.
<b>User name</b>	The user name to access the selected database.
<b>Password</b>	The password to access the selected database.

*Table continues...*

Name	Description
Connection string	The connection string based on the server and database you select.
Test Connection	A button to test if you can connect to the selected database on the selected server.
Contact Database	
Server name	The name of a server on which you have configured the <b>ASContact</b> database.
Database name	The name of a database that you have configured for storing contacts.
User name	The user name to access the selected database.
Password	The password to access the selected database.
Connection string	The database connection string based on the server and database you select.
Test Connection	A button to test if you can connect to the selected database on the selected server.

---

## Adding a queue for Simple Messaging Media Store

### About this task

Using this procedure, you can add a queue for Simple Messaging Media Store.

### Procedure

1. Start Call Center Elite Multichannel Control Panel.
2. In the left pane, expand the **Simple Messaging Media Stores** node.
3. Expand the **Simple Messaging Media Store** node.
4. Right-click the **Queues for Media Gateway** node and click **Add Queue**.
5. On the **Add Queue** tab, enter appropriate values in the fields.
6. Right-click anywhere on the **Add Queue** tab and click **Save And Close**.

---

## Add Queue for Simple Messaging Media Store field descriptions

Name	Description
Queue ID	A unique identifier for this queue.

*Table continues...*

Name	Description
<b>Media Director queue</b>	The identifier of the queue in Media Director that this queue sends simple message conversation requests to.
<b>Queue status</b>	<p>The operating status of a queue.</p> <p>Following are the possible status values:</p> <ul style="list-style-type: none"> <li>• <b>Open:</b> The queue is currently open.</li> <li>• <b>Closed:</b> The queue is currently closed.</li> <li>• <b>Use Operating Hours:</b> The queue is open only during the hours specified in a schedule, attached to a program that the queue uses.</li> </ul>
<b>Program ID</b>	<p>The ID of the program you want this queue to use.</p> <p> <b>Note:</b></p> <p>The program must be sourced from the ASMediaStore database where the Simple Messaging Media Store is connected to.</p>
<b>Culture</b>	<p>A locale that a queue uses when sending progress messages to a customer. For example, if you use the standard en locale, the system displays messages in English.</p> <p>The following locales are available for a queue:</p> <ul style="list-style-type: none"> <li>• fr-French</li> <li>• de-German</li> <li>• it-Italian</li> <li>• es-Spanish</li> <li>• es-Co-Spanish Colombian</li> <li>• pt-Portuguese (Brazilian)</li> <li>• ru-Russian</li> <li>• ko-Korean</li> <li>• ja-Japanese</li> <li>• zh-CHT-Traditional Chinese</li> <li>• zh-CHS-Simplified Chinese</li> </ul> <p>Standard localized strings are retrieved from a set of compiled global resource files in Simple Messaging Media Store installation folder.</p> <p>In addition, you can define a custom culture. To use a custom culture, you must specify one of the custom cultures defined in the Globalization section of this configuration file, for example, fr-CA. The</p>

*Table continues...*

Name	Description
	section that relates to a particular culture contains the custom language resource identifier and custom format for operating hours.
<b>Request validation function</b>	A type of customer ID validation. This value represents a stored function in the SQL Server database. Values are IsMatchExactAddress or IsMatchOnEmailAddress. If you do not specify the validation or if the validation that you specify nonexistent on the SQL Server, the system uses IsMatchExactAddress.
<b>Suppress going backwards progress messages</b>	The check box to stop sending progress messages to customers informing about the location of their call in a queue shifts backward. This happens when a queue receives a high-priority work item from a customer.
<b>Seconds before offline interaction expires</b>	<p>The number of seconds an offline work item that an agent has replied to waits at the agent desktop before expiring. The offline work item can be a work item that is created from a text message.</p> <p>The offline work item expires if the agent does not receive a reply from the customer within a specified time. If the customer replies after the specified time limit, the system adds the reply in a database and queue it for the delivery as per the regular queuing process.</p>
<b>Offline interaction autoclose</b>	The check box to automatically close an offline work item. The offline work item can be created from a text message, after an agent replies to it.

---

## Viewing an existing queue

### About this task

Using this procedure, you can view an existing queue.

### Procedure

1. Start Call Center Elite Multichannel Control Panel.
2. In the left pane, expand the **Simple Messaging Media Stores** node.
3. Expand the **Simple Messaging Media Store** node.
4. Expand **Queues for Media Gateways** node
5. Click the node of a queue that you want to view.

The system displays the queue summary in the Summary Tab in General and Customer Parameters sections.

The Customer Parameters section displays information from the media stores configuration file and the ASMediaStore database.

---

## Closing a queue

### Procedure

1. Start Call Center Elite Multichannel Control Panel.
2. In the left pane, expand the **Simple Messaging Media Stores** node.
3. Expand the **Simple Messaging Media Store** node.
4. Expand the **Queues for Media Gateways** node.
5. Right-click a queue node and click **Close**.

---

## Reopening a queue

### About this task

Using this procedure, you can reopen a queue.

### Procedure

1. Start Call Center Elite Multichannel Control Panel.
2. In the left pane, expand the **Simple Messaging Media Stores** node.
3. Expand the **Simple Messaging Media Store** node.
4. Expand the **Queues for Media Gateways** node.
5. Right-click a queue node and click **Open**.

---

## Opening or closing a queue based on schedule

### About this task

Using this procedure, you can automatically close and open a queue according to the operating hours.

### Procedure

1. Start Call Center Elite Multichannel Control Panel.
2. In the left pane, expand the **Simple Messaging Media Stores** node.
3. Expand the **Simple Messaging Media Store** node.
4. Expand the **Queues for Media Gateways** node.
5. Right-click a queue node and click **Use Operating Hours**.

## Web Chat Gateway

Web Chat is a collection of the following components:

- Web Chat Gateway on a server within the internal network.
- Web Chat ASP (client application) on the IIS web server.
- Web Chat Web Service (ISAPI extension) on the IIS web server.

**\* Note:**

Before configuring the Web chat gateway, install Web chat for IIS and create all the accounts required for Simple Messaging Service queues. This gives you remote service IDs and passwords needed to complete this configuration.

After the configuration is complete, the customers must add each account name to the contact list in their instant messenger client.

## Configuring the Web Chat Gateway

### Before you begin

Ensure that you have installed Web Chat Gateway. For instructions on how to install Web Chat Gateway, see the *Installing Avaya Aura® Call Center Elite Multichannel*.

### Procedure

1. Start Call Center Elite Multichannel Control Panel.
2. In the left pane, expand the **Web Chat Gateway** node.
3. Right-click the **Web Chat Gateway** node and click **Edit**.
4. On the **Edit Gateway** tab, enter appropriate values in the fields.
5. Right-click anywhere on the **Edit Gateway** tab and click **Save And Close**.

### Edit Gateway field descriptions

Name	Description
<b>Simple Messaging Media Store</b>	You can specify the field values as mentioned in <a href="#">Edit Email Media Store field descriptions</a> on page 135.
<b>Error Logging</b>	You can specify the field values as mentioned in <a href="#">Error Logging</a> on page 339.
<b>Gateway Details</b>	
<b>Server instance friendly name</b>	A friendly name for the gateway instance.
<b>Gateway name</b>	The unique name for this gateway.

*Table continues...*

Name	Description
<b>Culture</b>	The culture to be used for messaging to customers, who are connecting to the gateway Value Standard or Custom defined in SMMS culture name.  The default value is empty.
<b>Seconds to reconnect to Simple Messaging Media Store</b>	The delay, in seconds, before this gateway tries to reconnect with Simple Messaging Media Store. The default value is 60.
<b>Minutes to close idle session</b>	The maximum time interval, in minutes, for a Session to be Idle. The system closes the session after the specified interval.  The default value is 2 minutes.
<b>Request validation function</b>	The name of the function to validate customer request. The value represents user defined Stored Function in the SQL server ASContact database. If you keep this field blank or there is no stored function exist on the SQL server, the system uses the appropriate standard function for Web Chat gateway.

## Adding a Web Chat remote service

### About this task

Using this procedure, you can add Web chat remote service.

### Procedure

1. Start Call Center Elite Multichannel Control Panel.
2. In the left pane, expand the **Web Chat Gateways** node.
3. Expand the **Web Chat Gateway** node.
4. Right-click the **Remote Services** node and click **Add Web Chat Service**.
5. On the **Add Service** tab, enter appropriate values in the fields.
6. Right-click anywhere on the **Add Service** tab and click **Save And Close**.

## New Web Chat Service field descriptions

Name	Description
<b>General Properties</b>	
<b>Remote service name</b>	A unique name for the remote service.
<b>Remote service type</b>	The type of remote service within Call Center Elite Multichannel Control Panel.

*Table continues...*

Name	Description
<b>Remote service startup type</b>	<p>A setting that determines how a remote service starts.</p> <p>The following are the options to start a remote service:</p> <ul style="list-style-type: none"> <li>• <b>Automatic:</b> Remote service starts automatically when the gateway starts.</li> <li>• <b>Manual:</b> Remote service must be started manually.</li> <li>• <b>Disable:</b> Remote service is disabled.</li> </ul>
<b>Remote service application management icon</b>	<p>The directory path of the icon that displays within Call Center Elite Multichannel Control Panel for the remote service. If you leave the parameter blank, a default icon is used.</p>
<b>Remote service ID</b>	<p>The account registered on Web for this service queue. The default ID is <i>Sales</i>.</p>
<b>Remote service password</b>	<p>The password to log in to the Web service. The default password is <i>CCEUser0</i>, which expires every 30 days. You must either set the required setting to <i>Never expires</i> or change the password every 30 days.</p> <p> <b>Note:</b></p> <p>The password must be same as the User Password that was specified when the Web Chat Service was installed. If a password-protected user account was not created during the Web Chat Service installation, leave this text box blank.</p>
<b>Remote service IP</b>	<p>The IP address or host name of the web service. The default is localhost.</p>
<b>Remote service port</b>	<p>The port number of the remote service. The default value is 80.</p>
<b>Seconds to reconnect to remote service</b>	<p>How often, in seconds, Web chat gateway attempts to reconnect to the remote service. The default value is 60 seconds.</p>
<b>Maximum service size bytes</b>	
<b>Autorestart if no interactions</b>	
<b>Extra Properties</b>	
<b>Remote Service URL</b>	<p>The URL of the Web Chat Web Service. By default, this field is blank.</p>
<b>Remote Service URI</b>	<p>The URI of the Web Chat Web Service.</p>

*Table continues...*



Name	Description
	In this case, use <code>/WebChatService/Service.asmx</code> .
<b>Use SSL</b>	If this is set <code>True</code> , you can use secure https connections.
<b>Seconds to Poll Remote Service</b>	How often, in seconds, Web Chat gateway polls the <code>ATWebChatExt.dll</code> when the connection is asynchronous. The accepted value range is 1-10 seconds. If the value is outside this range, a default value of 5 is applied. If the connection is synchronous, this parameter is ignored.
<b>Address Type</b>	A number that defines the address type for this media gateway. This address type helps to identify the customer in the ASContact database. The default is 0, which means unknown or identification not required.  You must set this field to link the contact. The value of this field must be set according to the value configured in the ASContact database.
<b>Channels</b>	
<b>Simple Messaging Media Store queue</b>	The name of the Simple Messaging Media Store queue that receives conversation requests from this service.
<b>Simple Messaging Media Store queue priority</b>	A value that indicates the priority of the work item objects to be queued in Media Director.  Default priority is 5. Use 1 for the highest priority. There is no limit for the lower-priority.
<b>Add</b>	The button to identify the Simple Messaging Media Store queue that receives conversation requests from this service.

---

## Customizing Web Chat ASP

### Before you begin

Using this procedure, you can customize Web Chat ASP.

### Procedure

1. Find the WebChatASP folder on your IIS web server: `\Avaya Aura CC Elite Multichannel\Server\Media Gateways\Web Chat for IIS`.
2. Open the web.config file in a text editor such as, Notepad.
3. Customize the following remote services parameters if required:
  - `serviceName`

- serviceID

**\* Note:**

Usually, you must not change the default configuration data in the web.config file. If you enter the remote service names and IDs during the installation of the Web Chat ASP, you do not need to configure them manually via the web.config file.

The web.config file can contain as many services as desired, but must contain at least one service. Each **serviceName** and **serviceID** pair must match a **Remote Service Name** and **Remote Service ID** combination already configured in Web Chat Gateway.

4. Where necessary, configure the following remote application parameters:

- ServicePriority
- PollInterval
- CultureID
- MaxMessageSize
- MimeType
- DisplayDebugMessages
- WebChatService.Service
- uiCulture

For detailed field descriptions, see [Web Chat ASP field descriptions](#) on page 171.

**\* Note:**

You must restart Web Chat Gateway before connecting to the webpage.

**Example of remote services parameters configured**

```
<webChat>
  <services>
    <service serviceName="Sales Support" serviceID="Sales"/>
    <service serviceName="Service Support" serviceID="Services"/>
  </services>
</webChat>
```

**Example of application parameters configured:**

```
<add key="ServicePriority" value="5"/>
<add key="PollInterval" value="5"/>
<add key="CultureID" value=""/>
<add key="MaxMessageSize" value="1024"/>
<add key="MimeType" value="text/plain"/>
<add key="DisplayDebugMessages" value="false"/>
<add key="WebChatService.Service" value="http://localhost/WebChatWebService/Service.asmx"/>
</appSettings>
<system.web>
  <globalization uiCulture="en-US"/>
```

## Web Chat ASP field descriptions

Name	Description
<b>Remote services parameters</b>	
<b>serviceName</b>	A user-friendly name for the service. This parameter must correspond with a Remote Service Name defined in Web Chat Gateway
<b>serviceID</b>	Text that identifies the remote service. This parameter must correspond with a Remote Service ID in Web Chat Gateway.
<b>Application parameter</b>	
<b>ServicePriority</b>	The service priority. Valid values are 1-9, where 1 is the highest priority. The default is 5. Note: This value applies to every service.
<b>PollInterval</b>	How often, in seconds, messages from the service are checked. The default is 5.
<b>CultureID</b>	This setting is used to select the language (either standard or custom) for customer progress messages, for example, fr-FR will display French progress messages.
<b>MaxMessageSize</b>	The maximum number of characters the customer can insert in the Send panel of the Web Chat ASP application. The default is 1024.
<b>MimeType</b>	The type of the customer's outgoing messages. Valid values are: "text/plain" and "text/html". The default is text/plain.
<b>DisplayDebugMessages</b>	If you set this parameter to True, then debugging messages are displayed on your screen. This is not mandatory in a production environment, but may be helpful if you encounter problems setting up web chat. Should be set to False.
<b>WebChatService.Service</b>	The address of the Web Chat Web Service. The default is <a href="http://localhost/WebChatWebService/Service.aspx">http://localhost/WebChatWebService/Service.aspx</a> . If you have installed Web Chat Web Service on a different computer, replace localhost with the IP address of that computer.
<b>uiCulture</b>	The resource file to load user interface text.

---

## Customizing Web Chat Web Service

### Before you begin

Using this procedure, you can customize Web Chat Web service.

## Procedure

1. Find the WebChatWebService folder on your IIS web server: \ Avaya Aura CC Elite Multichannel\Server\Media Gateways\Web Chat for IIS.
2. Open the “web.config” file in a text editor such as, Notepad.
3. Where necessary, customize the following parameters:
  - ErrLogEnabled
  - ErrLogFilePath
  - ErrLogLevel
  - ErrLogFileExt
  - ErrLogMaxFileSizeKB
  - UserName

**\* Note:**

Usually, you must not change the default configuration data in the web.config file. If you create a password protected user account during the installation of the Web Chat Web Service, the user name is saved in the web.config file and both the user name and password are saved into the Windows user account.

### Example

```
<appSettings>
  <add key="ErrLogEnabled" value="false"/>
  <add key="ErrLogFilePath" value="logs"/>
  <add key="ErrLogLevel" value="1"/>
  <add key="ErrLogFileExt" value="WC.log"/>
  <add key="ErrLogMaxFileSizeKB" value="1000"/>
  <add key="UserName" value="{Windows User Account}"/>
</appSettings>
```

## Web Chat Web Service field descriptions

Name	Description
<b>ErrLogEnabled</b>	A setting that allows you to write application error information to error log files. True=enabled, False=disabled. The default is False.  Enabling error logging will require write access to the ErrLogFilePath. Please test the application after enabling error logging.
<b>ErrLogFilePath</b>	The directory path for saving error log files. If left blank, this parameter automatically sets the path to the application's current working folder (the same folder as the application executable).

*Table continues...*

Name	Description
	By default, the web.config file uses the subdirectory "logs".
<b>ErrLogLevel</b>	<p>The value that determines what level of error detail will be saved in the error log: 0=No error logging takes place, 1=Logs fatal, major, minor and trace information, 2=Logs fatal, major and minor errors, 4=Logs fatal and major errors, 8=Logs fatal errors only.</p> <p>There is also another error log level, which enables you to create log files that don't override each other every time the maximum log file size limit is reached. This logging level is designed for diagnostic purposes only and can be achieved by adding 128 to one of the logging level values mentioned above. For example, if you specify "129", new error log files will be continuously created for this application that contain fatal, major, minor and trace information.</p>
<b>ErrLogFileExt</b>	<p>The extension of error log files for this application. Extension refers to part of the file name (usually the name of the application) and the file type extension (for example, .log) The application will automatically precede the default extension with the day of the week (for example, Mon, Tue) when it creates its error logs.</p> <p>By default, the web.config file uses the subdirectory "WC.log".</p>
<b>ErrLogMaxFileSizeKB</b>	<p>The maximum amount of information, in kilobytes, that will be stored in an error log file before it is archived and a new file is created. The default is 1000. The minimum you can set this to is 100. Note: The archive will only store one log file. If a second error log reaches the specified maximum size, it overrides the previously archived file. If, however, the diagnostic testing error log level is selected in ErrLogLevel (this is achieved by adding 128 to any one of the other error log values), a new file with a new name is created every time the maximum log file size limit is reached.</p>
<b>UserName</b>	<p>The user name for a legitimate Windows user account.</p> <p> <b>Note:</b></p> <p>If you created a password-protected user account during the installation of the Web Chat</p>

*Table continues...*

Name	Description
	<p>Web Service, you do not need to manually configure the UserName via the web.config file.</p> <p>If you didn't create a password-protected user account during the installation of the Web Chat Web Service but now require Web Chat Gateway authentication for the Web Chat Web Service, you should set the 'UserName' to the name of a new (or existing) Windows user account on the local machine (where Web Chat Web Service is running). Make sure the password for this Windows account is specified as the <b>Remote Service Password</b> when you are configuring remote services in the Web Chat Gateway.</p> <p>If authentication is required on a Win2000 machine, the following additional settings should be done:</p> <ul style="list-style-type: none"> <li>• Open <b>Control Panel &gt; Administrative Tools &gt; Local Security Policy</b>.</li> <li>• Expand <b>Local Policies</b> and select <b>User Rights Assignment</b>.</li> <li>• Double-click <b>Act as part of the operating system</b>.</li> <li>• Add <b>ASP.NET user (IIS 5)</b> or <b>Local Service user (IIS 6)</b>.</li> <li>• Restart <b>Win2000</b>.</li> </ul> <p>If you don't require Web Chat Gateway authentication for the Web Chat Web Service, leave this parameter blank.</p>

---

## Supported browsers for Web Chat ASP

The following browsers are supported for Web Chat ASP:

- Internet Explorer 7, 8, 9, 10
- Firefox (version 23)
- Chrome (version 29)
- Opera (version 12)
- Safari for Mac

---

# AOL-ICQ Instant Messenger Gateway

---

## Configuring an AOL-ICQ Instant Messenger Gateway

### Before you begin

Before configuring the AOL-ICQ Instant Messenger Gateway, you must install the AOL-ICQ Instant Messenger Gateway. For instructions on how to install AOL-ICQ Instant Messenger Gateway, see the *Installing Avaya Aura® Call Center Elite Multichannel*.

You can download *Installing Avaya Aura® Call Center Elite Multichannel* from the Avaya Support website: <http://support.avaya.com>.

### \* Note:

Before configuring the AOL-ICQ Instant Messenger Gateway, register all accounts required for Simple Messaging Service queues with your remote service provider. This gives you remote service IDs and passwords to complete this configuration.

### About this task

Using this procedure, you can configure an AOL-ICQ Instant Messenger Gateway.

### Procedure

1. Start Call Center Elite Multichannel Control Panel.
2. In the left pane, expand the **AOLICQ Instant Messenger Gateways** node.
3. Right-click the **AOL-ICQ Instant Messenger Gateway** node and click **Edit**.
4. On the **Edit Gateway** tab, enter appropriate values in the fields.
5. Right-click anywhere on the **Edit Gateway** tab and click **Save And Close**.

### \* Note:

After the configuration is complete, customers must add each account name to the contact list in their instant messenger client.

### Related Links

[Edit Gateway field descriptions](#) on page 166

---

## Adding an AOL-ICQ Instant Messenger remote service

### About this task

Using this procedure, you can add AOL or ICQ Instant Messenger remote service.

### Procedure

1. Start Call Center Elite Multichannel Control Panel.

2. In the left pane, expand the **AOLICQ Instant Messenger Gateways** node.
3. Expand the **AOL-ICQ Instant Messenger Gateway** node.
4. Right-click the **Remote Services** node and click **AOL Instant Messenger Service** or **Add ICQ Service**.
5. On the **Add Service** tab, enter appropriate values in the fields.
6. Right-click anywhere on the **Add Service** tab and click **Save And Close**.

**Related Links**

[New AOL-ICQ Service field descriptions](#) on page 176

**New AOL-ICQ Service field descriptions**

Name	Description
<b>General Properties</b>	
<b>Remote service name</b>	A unique name for this remote service. The name is used for display purposes and can be set to anything. For example, the Sales department.
<b>Remote service type</b>	Text that identifies the type of remote service within Call Center Elite Multichannel Control Panel.
<b>Remote service startup type</b>	<p>A setting that determines how a remote service starts.</p> <p>The following are the methods to start a remote service:</p> <ul style="list-style-type: none"> <li>• <b>Automatic.</b> Remote service starts automatically when the gateway starts.</li> <li>• <b>Manual.</b> Remote service needs to be started manually.</li> <li>• <b>Disable.</b> Remote service is disabled.</li> </ul>
<b>Remote service application management icon</b>	The directory path of the icon that appears within Call Center Elite Multichannel Control Panel for this remote service. If you leave the parameter blank, a default icon is used.
<b>Remote service ID</b>	<p>The AOL or ICQ account name registered on AOL or ICQ Instant Messenger for this service queue.</p> <p>Do not include spaces or uppercase characters in ID and limit the ID upto 16 characters.</p>
<b>Remote service password</b>	The password to log in to the AOL or ICQ Instant Messenger service.
<b>Remote service nickname</b>	<p>A user-friendly name for the remote service.</p> <p>The system displays this name in the AOL or ICQ Instant Messenger at customer.</p>

*Table continues...*



Name	Description
	The nickname must be the same as the Remote service ID. You can use spaces and uppercase characters.
<b>Remote service IP</b>	The IP address or host name of the AOL or ICQ Instant Messenger service. In this case, use either login.oscar.aol.com or login.icq.com.
<b>Remote service port</b>	The port number of the remote service. The default value is 5190.
<b>Seconds to reconnect to remote service</b>	How often, in seconds, AOL-ICQ Instant Messenger Gateway attempts to reconnect to the remote service. Default is 60 seconds.
<b>Maximum message size bytes</b>	<p>The maximum number of bytes that the system can send in a single message before it splits the message into another message.</p> <p> <b>Warning:</b></p> <p>The system can split a word that is at the end of the part message. Keep the maximum message size to 1024.</p>
<b>Autorestart if no interactions</b>	<p>This check box allows you to automatically restart the remote service of this gateway when a critical parameter for this gateway is changed through Call Center Elite Multichannel Control Panel and when there is no any interaction open or after all the open interaction closes.</p> <p>If you clear this check box, you must manually restart the remote service of this gateway to enable changing critical parameters in Call Center Elite Multichannel Control Panel.</p>
<b>Extra Properties</b>	
<b>Goodbye Phrase</b>	A phrase that closes the instant message conversation when an agent types it in the instant messenger. For example: Goodbye phrase=Goodbye.
<b>Channels</b>	
<b>Simple Messaging Media Store queue</b>	The name of the Simple Messaging Media Store queue that receives conversation requests from this service.
<b>Simple Messaging Media Store queue priority</b>	<p>A value that indicates the priority of the work item objects to be queued in Media Director.</p> <p>Default priority is 5.</p> <p>1 is for the highest-priority. There is no limit for the lower-priority.</p>

*Table continues...*

Name	Description
Add	This button lets you identify the Simple Messaging Media Store queue that receives conversation requests from this service.

---

## MSN Messenger Gateway

---

### Configuring an MSN Messenger Gateway

#### Before you begin

Before you begin configuring the MSN Messenger Gateway, the MSN Messenger Gateway must be installed. For instructions on how to install MSN Messenger Gateway, see *Installing Avaya Aura® Call Center Elite Multichannel*.

 **Note:**

Before configuring the MSN Messenger Gateway, register all the accounts required for Simple Messaging Service queues with your remote service provider. This gives you remote service IDs and passwords required to complete this configuration.

Registering accounts in MSN Messenger, AOL Instant Messenger, and ICQ Instant Messenger is free.

#### Procedure

1. Start Call Center Elite Multichannel Control Panel.
2. In the left pane, expand the **MSN Messenger Gateways** node.
3. Right-click the **MSN Messenger Gateway** node and click **Edit**.
4. On the **Edit Gateway** tab, enter appropriate values in the fields.
5. Right-click anywhere on the **Edit Gateway** tab and click **Save And Close**.

 **Note:**

After the configuration is complete, customers must add each account name to the contact list in their instant messenger client.

#### Related Links

[Edit Gateway field descriptions](#) on page 166

## Adding an MSN Instant Messenger remote service

### About this task

Using this procedure, you can add MSN Instant Messenger remote service.

### Procedure

1. Start Call Center Elite Multichannel Control Panel.
2. In the left pane, expand the **MSN Messenger Gateways** node.
3. Expand the **MSN Messenger Gateway** node.
4. Right-click the **Remote Services** node and click **Add MSN Instant Messenger Service**.
5. On the **Add Service** tab, enter appropriate values in the fields.
6. Right-click anywhere on the **Add Service** tab and click **Save And Close**.

### Related Links

[New MSN Messenger Service field descriptions](#) on page 179

## New MSN Messenger Service field descriptions

Name	Description
<b>General Properties</b>	
<b>Remote service name</b>	A unique name for this remote service.
<b>Remote service type</b>	The type of remote service within Call Center Elite Multichannel Control Panel.
<b>Remote service startup type</b>	<p>A setting that determines how a remote service starts.</p> <p>The following are the options to start a remote service:</p> <ul style="list-style-type: none"> <li>• <b>Automatic:</b> Remote service starts automatically when the gateway starts.</li> <li>• <b>Manual:</b> Remote service must be started manually.</li> <li>• <b>Disable:</b> Remote service is disabled.</li> </ul>
<b>Remote service application management icon</b>	The directory path of the icon that displays within Call Center Elite Multichannel Control Panel for this remote service. If you leave the parameter blank, a default icon is used.
<b>Remote service ID</b>	The email address registered on MSN Messenger for this service queue.
<b>Remote service password</b>	The password to log in to the MSN Messenger service.

*Table continues...*

Name	Description
<b>Remote service nickname</b>	A user-friendly name for the remote service. The system displays this name in the MSN Messenger at customer.
<b>Remote service IP</b>	The IP address or host name of the MSN Messenger service. In this case, use: messenger.hotmail.com.
<b>Remote service port</b>	The port number of the remote service. The default value is 1863.
<b>Seconds to reconnect to remote service</b>	How often, in seconds, MSN Messenger gateway attempts to reconnect to the remote service. The default value is 60 seconds.
<b>Maximum message size bytes</b>	The maximum number of bytes that the system can send in a single message before it splits the message into another message.   <b>Warning:</b> The system can split a word that is at the end of the part message. The valid range for this gateway is 128-1664 bytes. You can enter this value as 1024.
<b>Autorestart if no interactions</b>	With this check box, you can automatically restart the remote service of this gateway. You can perform this action when a critical parameter for this gateway is changed through Call Center Elite Multichannel Control Panel and no interactions are open, or as soon as all open interactions close.  If this check box are clear, you must manually restart the remote service of this gateway to enable changing critical parameters in Call Center Elite Multichannel Control Panel.
<b>Extra Properties</b>	
<b>MSN Version</b>	The MSN protocol versions that are used by MSN Messenger gateway. The default is: MSNP9 MSNP8. Do not change the default unless required.
<b>CVR Parameter</b>	The version information about the client and operation system. The default is: 0 x 0409 winnt 5.1 i386 MSNMSGR 5.0.0540 MSMSGs. Do not change the default unless required.
<b>Channels</b>	
<b>Simple Messaging Media Store queue</b>	The name of the Simple Messaging Media Store queue that receives conversation requests from this service.
<b>Simple Messaging Media Store queue priority</b>	A value that indicates the priority of the work item objects to be queued in Media Director.

*Table continues...*

Name	Description
	The default priority is 5. The highest-priority is 1. There is no limit for the lower-priority.
<b>Add</b>	With this button, you can identify the Simple Messaging Media Store queue that receives conversation requests from this service.

---

## Short Message Service Gateway

---

### Configuring Short Message Service Gateway

#### Before you begin

Before configuring the Short Message Service Gateway, you must install the Short Message Service Gateway. For instructions on how to install Short Message Service Gateway see the *Installing Avaya Aura® Call Center Elite Multichannel*.

You can download *Installing Avaya Aura® Call Center Elite Multichannel* from the Avaya Support website: <http://support.avaya.com>.

#### \* Note:

Before configuring the Short Message Service Gateway, register all accounts required for Simple Messaging Service queues with your remote service provider. This gives you remote service IDs and passwords to complete this configuration.

There are charges applicable for signing up with an SMS provider and registering SMS accounts.

#### Procedure

1. Start Call Center Elite Multichannel Control Panel.
2. In the left pane, expand the **SMS Gateways** node.
3. Right-click the **SMS Gateway** node and click **Edit**.
4. On the **Edit Gateway** tab, enter appropriate values in the fields.
5. Right-click anywhere on the **Edit Gateway** tab and click **Save And Close**.

#### \* Note:

After the configuration is complete, customers must add each account name to the contact list in their instant messenger client.

#### Related Links

[Edit Gateway field descriptions](#) on page 166

## Adding a Short Message Service remote service

### About this task

Using this procedure, you can add a Short Message Service remote service.

### Procedure

1. Start Call Center Elite Multichannel Control Panel.
2. In the left pane, expand the **SMS Gateways** node.
3. Expand the **SMS Gateway** node.
4. Right-click the **Remote Services** node and click **Add Short Message Service**.
5. On the **Add Service** tab, enter appropriate values in the fields.
6. Right-click anywhere on the **Add Service** tab and click **Save And Close**.

### New Short Message Service field descriptions

Name	Description
<b>General Properties</b>	
<b>Remote service name</b>	A unique name for this remote service.
<b>Remote service type</b>	The type of remote service within Call Center Elite Multichannel Control Panel.
<b>Remote service startup type</b>	<p>A setting that determines how a remote service starts.</p> <p>The following are the options to start a remote service:</p> <ul style="list-style-type: none"> <li>• <b>Automatic:</b> Remote service starts automatically when the gateway starts.</li> <li>• <b>Manual:</b> Remote service must be started manually.</li> <li>• <b>Disable:</b> Remote service is disabled.</li> </ul>
<b>Remote service application management icon</b>	The directory path of the icon that displays within Call Center Elite Multichannel Control Panel for the remote service. If you leave the parameter blank, a default icon is used.
<b>Remote service ID</b>	The account registered on SMS for this service queue.
<b>Remote service password</b>	The password to log in to the SMS service.
<b>Remote service IP</b>	The IP address or host name of the SMS service.
<b>Remote service port</b>	The port number of the remote service.

*Table continues...*

Name	Description
<b>Seconds to reconnect to remote service</b>	How often, in seconds, Short Message Service gateway attempts to reconnect to the remote service. The default value is 90 seconds.
<b>Maximum message size bytes</b>	<p>The maximum number of bytes that the system can send in a single message before the system splits the message to another message.</p> <p> <b>Warning:</b></p> <p>A word can split at the end of a part message. The value for this parameter is supplied by the Short Message Service Center provider. The value must not exceed 254 bytes. The default is 160.</p>
<b>Autorestart if no interactions</b>	<p>With the check box, you can automatically restart the remote service of this gateway. You can perform this action when a critical parameter for this gateway is changed through Call Center Elite Multichannel Control Panel and when there are no interactions open, or as soon as all open interactions close.</p> <p>If this check box is not selected, you must manually restart the remote service of this gateway to enable changing critical parameters in Call Center Elite Multichannel Control Panel.</p>
<b>Extra Properties</b>	
<b>Connection Mode</b>	The mode of connection. Possible values are: Transceiver and Transmitter and Receiver. The default is Transceiver.
<b>Timeout Interval Seconds</b>	The time, in seconds, Short Message Service gateway waits for a reply from the Short Message Service Center before time out. The default is 300.
<b>Enquire Link Interval Seconds</b>	The time, in seconds, Short Message Service gateway checks the connection to the Short Message Service Center. The default is 60 seconds.
<b>TON</b>	The type of phone number, the customer must dial to make contact with your contact center. The possible values are: Unknown, International, National, Network_specific, Subscriber_number, Alphanumeric, and Abbreviated. The Short Message Service Center provider provides the value you use for this parameter.
<b>NPI</b>	The Numbering Plan Indicator of your contact center phone number. The possible values are: Unknown, ISDN, Data, Telex, Land_Mobile, National, Private, ERMES, Internet_IP, and WAP_Client_Id. The Short

*Table continues...*

Name	Description
	Message Service Center provider provides the value you use for this parameter.
<b>Address Range</b>	The address or set of addresses, supplied by your Short Message Service Center provider. If your provider did not specify a value, leave this parameter blank.
<b>System Type</b>	The Short Message Service Center provider provides the value you use for this parameter.
<b>Maximum number of TXTs per message</b>	The maximum number of split messages that an agent can send if the message exceeds the value specified in the Maximum message size bytes field. If the number of split messages exceeds this parameter, only part of the message is sent to the customer. If set to 0, there is no limit on the number of split messages. The default is 2.
<b>Channels</b>	
<p> <b>Note:</b></p> <p>A remote service for SMS gateway can have addresses with multiple entries, such as phone numbers a customer can call to reach the service. The different remote services can be mapped to different queues.</p>	
<b>Channel ID</b>	A name for this group of channel parameters.
<b>Address</b>	The phone number that customers must call to reach the service this channel belongs to. The Short Message Service Center provider provides the value you use for this parameter.
<b>TON</b>	The type of phone number belongs to the customer. The possible values are: Unknown, International, National, Network_specific, Subscriber_number, Alphanumeric, and Abbreviated. The Short Message Service Center provider provides the value you use for this parameter.
<b>NPI</b>	The numbering plan indicator belonging to the customer. Possible values are: Unknown, ISDN, Data, Telex, Land_Mobile, National, Private, ERMES, Internet_IP, and WAP_Client_Id. The Short Message Service Center provider provides the value you use for this parameter.
<b>Simple Messaging Media Store queue</b>	The name of the Simple Messaging Media Store queue that receives conversation requests from this service.

*Table continues...*



Name	Description
<b>Simple Messaging Media Store queue priority</b>	A value that indicates the priority of the work item objects to be queued in Media Director.  Default priority is 5.  The highest priority is for 1. There is no limit for the lower priority.
<b>Add</b>	With this button, you can identify the Simple Messaging Media Store queues that receives conversation requests from this service.

---

## Communicator Gateway

---

### Configuring a Communicator Gateway

#### Before you begin

Before configuring the Communicator Gateway, you must install the Communicator Gateway. For instructions on how to install Communicator Gateway see the *Installing Avaya Aura® Call Center Elite Multichannel*.

**\* Note:**

Before configuring the Communicator Gateway, register all accounts required for Simple Messaging Service queues with your remote service provider. This gives you remote service IDs and passwords to complete this configuration.

Registering accounts in Communicator is free.

#### About this task

Using this procedure, you can configure a Communicator Gateway.

#### Procedure

1. Start Call Center Elite Multichannel Control Panel.
2. In the left pane, expand the **Communicator Gateways** node.
3. Right-click the **Communicator Gateway** node and click **Edit**.
4. On the **Edit Gateway** tab, enter appropriate values in the fields.
5. Right-click anywhere on the **Edit Gateway** tab and click **Save And Close**.

**\* Note:**

After the configuration is complete, customers must add each account name to the contact list in their instant messenger client.

**Related Links**

[Edit Gateway field descriptions](#) on page 166

## Adding an Office Communicator remote service

### About this task

Using this procedure, you can add an Office Communicator remote service.

### Procedure

1. Start Call Center Elite Multichannel Control Panel.
2. In the left pane, expand the **Communicator Gateways** node.
3. Expand the **Communicator Gateway** node.
4. Right-click the **Remote Services** node and click **Add Office Communicator Service**.
5. On the **Add Service** tab, enter appropriate values in the fields.
6. Right-click anywhere on the **Add Service** tab and click **Save And Close`**.

## New Office Communicator Service field descriptions

Field	Description
<b>General Properties</b>	
<b>Remote service name</b>	A unique name for this remote service.
<b>Remote service type</b>	The type of remote service within Call Center Elite Multichannel Control Panel.  For Example, Office Communicator Service.
<b>Remote service startup type</b>	A setting that determines how a remote service starts.  The following are the options to start a remote service: <ul style="list-style-type: none"> <li>• <b>Automatic:</b> Remote service starts automatically when the gateway starts.</li> <li>• <b>Manual:</b> Remote service must be started manually.</li> <li>• <b>Disable:</b> Remote service is disabled.</li> </ul>
<b>Remote service application management icon</b>	The directory path of the icon that displays within Call Center Elite Multichannel Control Panel for this remote service. If the parameter is blank, a default icon is used. The Icon file contains 16 x 16 and 32 x 32 images.The default is blank.
<b>Remote service ID</b>	The email address registered on Office Communicator for this service queue.

*Table continues...*

Field	Description
<b>Remote service password</b>	The password to log in to the Office Communicator service.
<b>Remote service nickname</b>	A meaningful and user-friendly name for the service. The customer can view this name in Office Communicator.
<b>Remote service IP</b>	The IP address or host name of the Office Communicator.
<b>Remote service port</b>	The port number of the remote service. The default port number is 5060.
<b>Simple Messaging Media Store Queue</b>	The name of the Simple Messaging Media Store Queue that receives the conversation requests from this service.
<b>Seconds to reconnect to remote service</b>	The time, in seconds, the gateway attempts to reconnect to the remote service. The default value is 60 seconds.
<b>Maximum message size bytes</b>	<p>The maximum number of bytes that the system can send in a single message before it splits the message into another message.</p> <p> <b>Note:</b></p> <p>A word can split at the end of a part message. The valid range for this gateway is 128-1664 bytes. You can enter the value as 1024.</p>
<b>Autorestart if no interactions</b>	<p>With the check box, you can automatically restart the remote service of this gateway. You can perform this action when a critical parameter for this gateway is changed through Call Center Elite Multichannel Control Panel and there are no interactions open, or as soon as all open, interactions close.</p> <p>If this check box is clear, you must manually restart the remote service of this gateway to enable changing critical parameters in Call Center Elite Multichannel Control Panel.</p>
<b>Extra Properties</b>	
<b>Presence Container ID</b>	<p>Enter the container ID to publish presence.</p> <p>Range: 1000-32000. Default: 7000.</p>
<b>SIP Transport Type</b>	Enter the SIP transport type. Either Transmission Control Protocol (TCP), Transport Layer Security (TLS), or Mutual Transport Layer Security (MTLS).
<b>Certificate</b>	<p>The format of the certificate:</p> <pre>&lt;Certificate Subject Common Name&gt; (&lt;Certificate Serial Number&gt;).</pre>

*Table continues...*

Field	Description
	The value in this field is required, if you select SIP Transport Type as MTLS.
<b>Authentication Protocol</b>	The authentication protocol for this service. Default: None
<b>Channels</b>	
<b>Channel ID</b>	A name for this group of channel parameters.
<b>Simple Messaging Media Store queue</b>	The name of the Simple Messaging Media Store queue that receives conversation requests from this service.
<b>Simple Messaging Media Store queue priority</b>	A value that indicates the priority of the work item objects to be queued in Media Director.  The default priority is 5.  The highest priority is for 1. There is no limit for the lower-priority.
<b>Add</b>	With this button, you can identify the Simple Messaging Media Store queues that receives conversation requests from this service.

## Methods to connect Communicator Gateway to Office Communicator Server

The following are the methods by which you can connect Communicator Gateway to Office Communicator Server.

### Method 1

For a registered domain user who logs in to Communicator Gateway, the following configurations are available. No further configuration is required.

- NON-Authorized host
- SIP address ID is the registered windows user who can log in to the domain AND this ID was used to log in to Windows
- Transport: TCP
- Authorization: NTLM, password is empty
- Remote Service Port: 5060
- Certificate: Not required

### Method 2

For a registered domain user who does not log in to Communicator Gateway, the following configurations are available. No further configuration is required.

- NON-Authorized host
- SIP address ID is a the registered windows user who can log in to the domain AND this ID was NOT used to log in to Windows
- Transport: TCP
- Authorization: NTLM + Windows logon password

- Remote Service Port: 5060
- Certificate: Not required

### Method 3

For any SIP address with the MTLs transport type, the following configurations are available. This method requires obtaining and deploying a TLC certificate.

- NON-Authorized host
- Any SIP address
- Transport: MTLs
- Authorization: N/A
- Remote Service Port: 5061
- Certificate: Required

### Method 4

For any SIP address with Communicator Gateway set up as a Trusted Host, the following configurations are available. This method requires setting up of a trusted host.

- Authorized host
- Any SIP Address
- Transport: TCP
- Authorization: N/A

## Retrieving and deploying a TLS certificate

### About this task

Use this procedure to retrieve and deploy a TLS certificate on the UC Managed API (UCMA) application using the local Certification Authority.

### Procedure

1. Log in to Office Communication Server as an administrator.
2. Start the Office Communication Server Management console.
3. Right-click the Office Communication server node and click **Certificates**.  
The Office Communication Server Certificate Wizard opens.
4. Click **Next**.  
The system displays the Available Certificate Task screen.
5. In the Available Certificate Task screen, select **Create a new certificate**, and click **Next**.  
The system displays the Delayed or Immediate Request screen.
6. In the Delayed or Immediate Request screen, select **Send the request immediately to an online certification authority** and click **Next**.  
The system displays the Name and Security Settings screen.
7. Enter the name for the new certificate and select the **Mark cert as exportable** check box.

8. Click **Next**.  
The system displays the Organization Information screen.
9. Select or enter the name and unit for the organization.
10. Click **Next**.  
The system displays the Your Server's Subject Name screen.
11. Select or enter the Fully Qualified Domain Name (FQDN) in the **Subject name** field and alternate subject name in the **Subject Alternate Name** field.
12. Click **Next**.  
The system displays the Geographical Information screen.
13. Select or enter the geographical information and click **Next**.  
The system displays the Choose a Certification Authority screen.
14. Select the certificate authority from the drop-down list and click **Next**.  
The system displays the Request Summary screen.
15. Check the summary of the options that you have selected and click **Next**.  
The system displays the Assign Certificate Task screen.
16. Select the Assign certificate immediately option and click **Next**.  
The system displays the Configure the Certificate(s) of your Server screen.
17. Check the certificate details and click **Next** to configure the default server certificate.  
The system displays the Certificate Wizard completed successfully screen.
18. Click **Finish** to complete the process and close the wizard.

### ***Setting up the Microsoft Management Console Procedure***

1. Run the **mmc** command to open the **Microsoft Management Console (MMC)**.
2. In the main menu bar, click **File > Add/Remove Snap-in**.  
The system displays the Add/Remove Snap-in screen.
3. Click **Add**.  
The system displays the Available standalone snap-ins screen.
4. Select **Certificates** and click **Add**.  
The system displays the Certificates snap-in screen.
5. Select **Computer account** and click **Next**.  
The system displays the Select Computer screen.
6. Select **Local computer** and click **Finish**.

- The system displays the certificate in the Add/Remove Snap-in screen.
7. In the Add / Remove Snap-in screen, click **OK** to close the dialog box.
  8. In **Microsoft Management Console**, select **Certificates (Local Computer) > Personal > Certificates** in the left pane.
  9. In the right pane, right-click the certificate that you created and select **All Tasks > Export**.  
The system displays the Certificate Export Wizard screen.
  10. Click **Next**.  
The system displays the Export Private Key screen.
  11. Select the **Yes, export the private key** check box to export the private key with password protection.
  12. Click **Next**.  
The system displays the Export File Format screen.
  13. Select the Enable strong protection option and click **Next**.  
The system displays the Password screen.
  14. Enter the password in the **Password** and **Confirm password** fields and click **Next**.  
The system displays the File to Export screen.
  15. Enter the file name and click **Next**.  
The system displays the Completing the Certificate Export Wizard screen.
  16. Read the summary and click **Finish**.
  17. Copy the certificate file to the UCMA application system.

### ***Opening the Certificate console on a system that has UCMA installed***

#### **Procedure**

1. Open the Certificate console.
2. In the left pane of Certificate console, right-click the **Personal Certificates** node and select **Certificates (Local Computer) > All Tasks > Import**.  
The system displays the Certificate Import wizard screen.
3. Click **Next**.  
The system displays the File to Import screen.
4. Click **Browse** to select a certificate.
5. Select the certificate file from the folder and click **Open**.
6. After you select the certificate, click **Next**.  
The system displays the Password screen.
7. Enter the password and click the **Next**.

The system displays the Certificate Store screen.

8. Select the Place all certificates in the following stores option and select **Personal** from the Certificate store.
9. Click **Next**.

The system displays the Completing the Certificate Export Wizard screen.

10. Read the summary of the setting and click **Finish**.

The certificate displays in MMC.

 **Note:**

For security reasons, delete the certificate file after installation.

### **Setting up a trusted host**

#### **About this task**

Using this procedure, you can set up an application machine as a trusted host.

#### **Procedure**

1. Log in to Office Communication Server as an administrator.
2. Start the Office Communication Server Management console.
3. In the left pane, right-click the server name and select **Properties > Front End Properties**.

The system displays the Front End Properties screen.

4. Click the Host Authorization tab and click **Add**.

The system displays the Add Authorized Host screen.

5. Enter the IP address of application system that you want to register with Office Communication Server and select the **Treat As Authenticated** check box.
6. Click **OK** to add the host.

The host address is added in the authorized hosts list.

7. Click **OK** to complete the operation.

---

## **XMPP/GTalk Gateway**

---

### **Configuring an XMPP or a GTalk Gateway**

#### **Before you begin**

XMPP or GTalk Gateway must be installed. For instructions on how to install an XMPP or a GTalk Gateway see the *Installing Avaya Aura® Call Center Elite Multichannel*.



You can download *Installing Avaya Aura® Call Center Elite Multichannel* from the Avaya Support website: <http://support.avaya.com>.

**\* Note:**

Before configuring an XMPP or a GTalk Gateway, register all accounts required for the Simple Messaging Service queues with your remote service provider. The registration provides you remote service IDs and passwords to complete this configuration.

### About this task

Using this procedure, you can configure an XMPP or a GTalk Gateway.

### Procedure

1. Start Call Center Elite Multichannel Control Panel.
2. In the left pane, expand the **XMPP Gateways** node.
3. Right-click the **XMPP Gateway** node and click **Edit**.
4. On the **Edit Gateway** tab, enter appropriate values in the fields.
5. Right-click anywhere on the **Edit Gateway** tab and click **Save And Close**.

**\* Note:**

After the configuration is complete, customers must add each account name to the contact list in the instant messenger client.

---

## Adding an XMPP or a GTalk remote service

### About this task

Using this procedure, you can add an XMPP or a GTalk remote service.

### Procedure

1. Start Call Center Elite Multichannel Control Panel.
2. In the left pane, expand the **XMPP Gateways** node.
3. Expand the **XMPP Gateway** node.
4. Right-click the **Remote Services** node and click **Add XMPP Service** or **Add Google Talk Service**.
5. On the **Add Service** tab, enter appropriate values in the fields.
6. Right-click anywhere on the **Add Service** tab and click **Save And Close**.

### Related Links

[New XMPP Service field descriptions](#) on page 194

## New XMPP Service field descriptions

Name	Description
<b>General Properties</b>	
<b>Remote service name</b>	A unique name for this remote service. The name is used for display purposes. For example, Sales Department.
<b>Remote service type</b>	The type of remote service within Call Center Elite Multichannel Control Panel. For example, Google Talk Service or XMPP Service.
<b>Remote service startup type</b>	A setting that determines how a remote service starts.  The following are the options to start a remote service: <ul style="list-style-type: none"> <li>• <b>Automatic:</b> Remote service starts automatically when the gateway starts.</li> <li>• <b>Manual:</b> Remote service must be started manually.</li> <li>• <b>Disable:</b> Remote service is disabled.</li> </ul>
<b>Remote service application management icon</b>	The directory path of the icon that displays within Call Center Elite Multichannel Control Panel for the remote service.  If the parameter is blank, a default icon is used. The icon file contains 16 x 16 and 32 x 32 images. The default is blank.
<b>Remote service ID</b>	For Google Talk, the email address registered on Google Talk for this service queue. For XMPP, the name to login to the XMPP Server.
<b>Remote service password</b>	The password to log in to the XMPP Server or Google Talk service.
<b>Remote service nickname</b>	A user friendly name for the service. The customer can view this name in Google Talk. Currently not used in XMPP Gateway.
<b>Remote service IP</b>	The IP address or host name of the Google Talk service.
<b>Remote service port</b>	The port number of the remote service. The default port number is 5222.
<b>Seconds to reconnect to remote service</b>	The time, in seconds, the gateway attempts to reconnect to the remote service. The default value is 60 seconds.

*Table continues...*

Name	Description
<b>Maximum message size bytes</b>	<p>The maximum number of bytes that the system can send in a single message before it splits the message into another message.</p> <p> <b>Note:</b></p> <p>A word can split at the end of a part message. The valid range for this gateway is 128-1664 bytes. You can enter the value as 1024.</p>
<b>Autorestart if no interactions</b>	<p>With this check box, you can automatically restart the remote service of this gateway. you can perform this action when a critical parameter for this gateway is changed through Call Center Elite Multichannel Control Panel and no interactions are open, or as soon as all open interactions close.</p> <p>If this check box is clear, you must manually restart the remote service of this gateway to enable changing critical parameters in Call Center Elite Multichannel Control Panel.</p>
<b>Extra Properties</b>	
<b>Remote Service Domain</b>	The authenticating domain name of the XMPP service that you specify in the Remote service name field. You must provide a value in this field if you want to use a domain different from the domain of the XMPP Service ID. The value in this field is not for the GTalk service.
<b>Channels</b>	
<b>Channel ID</b>	A name for this group of channel parameters.
<b>Simple Messaging Media Store queue</b>	The name of the Simple Messaging Media Store queue that receives conversation requests from this service.
<b>Simple Messaging Media Store queue priority</b>	<p>A value that indicates the priority of the work item objects to be queued in Media Director.</p> <p>Default priority is 5.</p> <p>The highest priority 1. There is no limit for the lower-priority.</p>
<b>Add</b>	This button lets you identify the Simple Messaging Media Store queues that receives conversation requests from this service.

---

## Chat canned messages

The canned messages can be configured for a chat application. The system displays these canned messages to customers when they contact a contact center using a chat application.

In the configuration of few canned messages, you can also use the %%1 variable to display the system information in a message.

For example:

- If you use %%1 in the **WelcomeMorning**, **WelcomeAfternoon**, and **WelcomeEvening** canned messages, the system replaces %%1 with a customer name when a customer initiates a chat.
- If you use %%1 in the **PositionInQueue** message, the system replaces %%1 with a current position of a customer call in a queue. When system updates the position, a new message is sent to a customer with the updated position.

**\* Note:**

The message types are predefined and you cannot delete any message type.

For more information, see [Types of configurable Chat Canned Messages](#) on page 196.

## Types of configurable Chat Canned Messages

Message Type	Description
<b>WelcomeMorning</b>	The message which is displayed to a customer when the customer contacts a contact center in the morning session. The configured morning session starts from 12.00 AM to 11.59 AM
<b>WelcomeAfternoon</b>	The message which is displayed to a customer when the customer contacts to a contact center in the afternoon session. The configured afternoon session starts from 12.00 PM to 05.59 PM
<b>WelcomeEvening</b>	The message which is displayed to a customer when the customer contacts to a contact center in the evening session. The configured evening session starts from 06.00 PM to 11.59 PM
<b>GenericProblem</b>	The message which is displayed to a customer when a problem persists in contact center. For example, a session expires, a connection breaks, or an error occurs in a database.
<b>NotOperatingTime</b>	The message which is displayed to a customer to inform about the operating time of a contact center.
<b>PositionInQueue</b>	The message which is displayed to a customer to inform about current call position in a queue.
<b>EstablishedState</b>	The message which is displayed to a customer to inform the customer that the call is delivered to an agent and the customer can start conversation with the agent.
<b>QueueFull</b>	The message which is displayed to a customer to inform to call later as the queue is currently full and unable to accept new requests.

### Related Links

[Configuring canned messages](#) on page 197

## Creating a canned message group

### About this task

You must create a message group in the **Canned Messages** node for a database that you configure for the Media Store. To configure different messages for a single message type, you must create additional message groups and configure the required messages in these groups.

You must link this program to a Web chat queue to enable the system to deliver the canned messages to a customer, who contacts an agent using a chat application.

### Important:

If you change the group assigned to a program, you must restart Simple Messaging Media store to reflect changes in the program.

If you change a message in any canned message group, the system reflects the changes after few minutes. You can specify this period in the .ini file of Simple Messaging Media Store.

### Procedure

1. Start Call Center Elite Multichannel Control Panel.
2. In the left pane, expand the **Database Management** node.
3. Expand the **Media Store Database** node.
4. Expand the specific database node.
5. Right-click the **Canned Messages** node and click **Add CannedMessage Group**.
6. On the **Add Canned Message** tab, in the **CannedMessages group name** field, enter a group name.
7. Right-click anywhere on the **Add CannedMessage** tab and click **Save And Close**.

### Related Links

[Creating a program](#) on page 110

## Configuring canned messages

### About this task

Using this procedure, you can configure messages in a canned message group.

### Procedure

1. Start Call Center Elite Multichannel Control Panel.
2. In the left pane, expand the **Database Management** node.
3. Expand the **Media Store Database** node.
4. Expand the specific database node.
5. Expand the **Canned Messages** node.
6. Right-click a canned message group for which you want to configure messages and click **Manage CannedMessages**.

7. On the **Manage CannedMessages** tab, perform the following steps:
  - a. In the **CannedMessageName** column, click a message name for which you want to add or change the message.
  - b. In the **CannedMessageValue** column, enter or update the message for the corresponding canned message name.
  - c. Repeat step a and step b to configure other messages in a selected group.

The system saves the updated information when you click a message in another row.
8. Right-click anywhere on the **Manage CannedMessages** tab and click **Save And Close**.

# Chapter 9: Configuring Outbound channel

---

## Prerequisites for configuring Outbound channel

The following are the prerequisites for configuring Outbound channel:

- Call Center Elite Multichannel core services must be installed and running.
- Preview Contact Media Store must be installed and running.

---

## Checklist for configuring Outbound channel

The following checklist outlines the series of steps you must take to configure Outbound channel.

Step	Task	✓
1	Create a schedule in Media Store Database	
2	(Optional) Create an AutoText group/Work Code	
3	Create a program in Media Store Database	
4	Assign a schedule to a program in Media Store Database	
5	Create a Preview Contact Media Store queue in Media Director	
6	Configure Preview Contact Media Store	

---

## Creating a schedule

### About this task

You can create and assign a schedule to a program. The system automatically executes the program at the scheduled date and time. You can create a schedule that runs daily or weekly or a schedule that runs only once.

You can also select the work type in a schedule. The work type determines if the system runs the schedule on a working day or on a holiday.

**Procedure**

1. Start Call Center Elite Multichannel Control Panel.
2. In the left pane, expand the **Database Management** node.
3. Expand the **Media Store Database** node.
4. Expand a specific database node.
5. Right-click **Schedules** and click **Add Schedule**.
6. On the **Add Schedule** tab, enter appropriate values in the fields.
7. Right-click anywhere on the **Add Schedule** tab and click **Save And Close**.

---

**Add Schedule field descriptions**

Name	Description
<b>Schedule</b>	
<b>Name</b>	The name for the new schedule
<b>Work type</b>	The type of work that you want to schedule. 0- Normal 1- Holiday
<b>Schedule Time</b>	
<b>Start</b>	The starting time of a schedule.
<b>End</b>	The ending time of a schedule.
<b>Duration</b>	The duration of the schedule.
<b>Schedule Type</b>	The type of schedule you want to run. The types of schedules you can run are: • One off • Daily • Weekly
<b>Schedule Date</b>	
<b>Start</b>	The start date of a schedule.
<b>End</b>	The end date of a schedule.



---

## Creating an AutoText group/Work Code

### About this task

You can create different AutoText groups to categorize different AutoText entries that agents can use when processing work items. This action helps the agents to find the required AutoText entry from the application menu bar.

### Procedure

1. Start Call Center Elite Multichannel Control Panel.
2. In the left pane, expand the **Database Management** node.
3. Expand the **Media Store Database** node.
4. Expand a specific database node where you want to create the AutoText group.
5. Right-click the **AutoText/Work Code** node and click **Add AutoText Group**.
6. On the **Add AutoText** tab, in the **AutoText group name** field, enter a name for the AutoText group.
7. Right-click anywhere on the **Add AutoText** tab and click **Save And Close**.

---

## Adding AutoText entries in an AutoText group

### About this task

When an agent selects an AutoText menu from Call Center Elite Multichannel Desktop, the AutoText plug-in scans the value of a selected AutoText for variables and replaces the variables with the correct value. The AutoText plug-in replaces the unknown or missing variables with a space or empty string.

### Procedure

1. Start Call Center Elite Multichannel Control Panel.
2. In the left pane, expand the **Database Management** node.
3. Expand the **Media Store Database** node.
4. Expand a specific database node.
5. Expand the **AutoText/Work Code** node.
6. Right-click an AutoText group name and click **Manage AutoText Items**.
7. On the **Manage AutoTexts** tab, enter appropriate values in the following fields:
  - Topic
  - Key
  - Values
8. Right-click anywhere on the **Manage AutoTexts** tab and click **Save And Close**.

**\* Note:**

For a unique topic name, you can have multiple topics with the same key within a particular group. Similarly, for a unique key, you can have multiple keys with the same topic.

You can copy and paste data from one AutoText group to another AutoText group, double-click a cell to edit the value of an AutoText entry, and right-click a cell and select an option to insert a predefined variable into the value of an AutoText entry.

**Related Links**

[Manage AutoTexts field descriptions](#) on page 108

[Supported variables in the AutoText Plug-in](#) on page 108

**Manage AutoTexts field descriptions**

Name	Description
<b>Topic</b>	This is the name of a group of the related AutoText entries or work codes. For example, Membership.
<b>Key</b>	This is the name of the AutoText or work code. For example, Join.
<b>Value</b>	This is the text that the system displays when an agent selects an AutoText key. For work codes, the value is a number. For example, 11.

**Supported variables in the AutoText Plug-in**

You can use the following variables in the AutoText Plug-in.

Name	Description
<i>StationDN</i>	The station number of the agent using Call Center Elite Multichannel Desktop.
<i>StationName</i>	The name configured in Communication Manager for the station of an agent using Call Center Elite Multichannel Desktop.
<i>AgentID</i>	The agent ID of an agent who is logged in to the station using Call Center Elite Multichannel Desktop. If no agent is logged in, the system displays this variable as blank.

*Table continues...*

Name	Description
<i>AgentName</i>	<p>The name configured in Communication Manager for an agent who is logged in to the station using Call Center Elite Multichannel Desktop.</p> <p>If no agent is logged in, this variable shows a blank value.</p>
<i>LoggedInUser</i>	<p>The user name of a person logged in to a system that runs Call Center Elite Multichannel Desktop.</p>
<i>MachineName</i>	<p>The name of a system that is running Call Center Elite Multichannel Desktop.</p>
<i>InteractionData</i>	<p>A variable with additional parameters that specifies a topic and a key for data. This data is held in the extra data table associated with the currently selected work item.</p> <p>In this variable, the topic parameter is optional. The topic and key parameters are separated by colon. If the key contains a single character, such as asterisks (*), all values that matches with the specified topic are inserted.</p> <p>For example: &lt;%InteractionData:SMMS:Message %&gt;.</p> <p>In this example, the system processes the queue configuration data associated with a current work item, locates the SMMS topic and a Message key, and inserts the contents of the value into this variable.</p>
<i>ProgramData</i>	<p>A variable with additional parameters that specify a topic and a key for data. This data is part of the queue configuration data associated with a currently selected work item.</p> <p>In this variable, the topic parameter is optional. The topic and key parameters are separated by colon. If the key contains a single character, such as asterisk (*), all values that matches with the specified topic are inserted.</p> <p>This functionality of this variable is identical to the <b>InteractionData</b> variable, but with a different source of information.</p> <p>For example: &lt;%ProgramData:SMMS:Message%&gt;.</p> <p>In this example, the system processes the queue configuration data associated with a current work item, locates the SMMS topic and a Message key,</p>

*Table continues...*

Name	Description
	and inserts the contents of the value into this variable.
<i>Break</i>	This variable inserts a carriage return line-feed combination into the text at the specified point.
<i>LongDate</i>	This variable inserts the current date in the Long format. The date is formatted using the desktop locale information.
<i>ShortDate</i>	This variable inserts the current date in the Short format. The date is formatted using the desktop locale information.
<i>LongTime</i>	This variable inserts the current time in the Long format. The time is formatted using the desktop locale information.
<i>ShortTime</i>	This variable inserts the current time in the Short format. The time is formatted using the desktop locale information.
<i>UniversalTime</i>	This variable inserts the current time converted to Coordinated Universal Time (UTC) format.
<i>Environment Variable</i>	<p>A variable with an additional parameter, which is an environment variable name. AutoText Plug-in retrieves the associated value of this variable and inserts the value in the AutoText entry. The variable name and environment variable name are separated by colon.</p> <p>Example: <code>&lt;%Environment:USERNAME%&gt;</code>.</p> <p>The system searches the USERNAME parameter in the system environment.</p>

---

## Creating a program

### About this task

You can create programs to perform the database-related activities.

#### Note:

You can create a separate program to route Microsoft Dynamics CRM activities to Call Center Elite Multichannel Desktop agents. You can also create a separate program for outbound calls.

### Procedure

1. Start Call Center Elite Multichannel Control Panel.
2. In the left pane, expand the **Database Management** node.

3. Expand the **Media Store Database** node.
4. Expand the database node for which you want to create a program.
5. Right-click the **Programs** node and click **Add Program**.
6. On the **Add Program** tab, enter appropriate values in the fields.
7. Right-click anywhere on the **Add Program** tab and click **Save And Close**.

### Related Links

[Outbound programs for virtual agents](#) on page 215



## Add Program field descriptions

Name	Description
<b>Program</b>	
<b>Program ID</b>	A unique identifier for the program that you are currently creating.
<b>Name</b>	A common name for your program.
<b>Used by</b>	<p>The application that uses this program. For example, if you want Preview Contact Media Store to use this program, select the Preview Contact Media Store check box.</p> <p> <b>Note:</b></p> <p>If you create a new program for Preview Contact Media Store, the system displays the program in the <b>Interactions</b> list of Preview Contact Media Store, which connects to the same ASMediaStore database. From the Interactions list, you can assign a group of contacts to your program and save the contacts to the ASMediaStore Database. For more information, see <a href="#">Preview Contact Media Store</a> on page 83.</p>
<b>Description</b>	A brief description for your program.
<b>Prompt</b>	A welcome greeting that an agent use while contacting a customer.
<b>Service level seconds</b>	The service level time, in seconds, for the program created. Default is 0
<b>CC Elite Configuration tab - Program Configuration</b>	
<b>Auto Text list name</b>	An identifier for the AutoText group you want agents to view when the agents work on work items generated through this program.

*Table continues...*

Name	Description
<b>Canned Message list name</b>	A canned message group name from which you want to display the canned messages to customers.
<b>Program access mode</b>	A program is public that is, allowed or open, or private that is, denied or closed.
<b>CC Elite Configuration tab - Work Code</b>	
<b>Number of tab pages</b>	The number of tabs that you use for advanced work code. Default is 5.
<b>Minimum required work code(s)</b>	The minimum number of work codes that must be entered by the agent. Default is 1.
<b>Use Advanced Work Code style</b>	The check box to select advance work code style. The system disables the Standard work code list name field.
<b>Standard Work Code list name</b>	A name for the list of standard work codes that you have configured.
<b>Advanced Work Code list name</b>	The identifier of the AutoText group, in this case a group of work codes, that you want agents to view when agents work on work items generated through this program.
<b>Default work code</b>	The default work code. The default value is 0.
<b>CC Elite Configuration tab - Desktop Utility</b>	
<b>Automatically drop phantom call</b>	The check box to put an agent in the pending Auxiliary mode and drop the phantom call when the agent accepts a work item.
<b>Automatic drop reason code</b>	A reason code that the system uses when an agent enters in the Auxiliary mode. The default value is 0.
<b>Agent available on interaction close</b>	A condition based on which you want an agent to be available after the current interaction is closed.
<b>Auto accept non-voice interactions</b>	The check box to automatically accept all multimedia work items or interaction.
<b>CC Elite Configuration tab - Preview Contact Client</b>	
<b>Client action</b>	<p>An option that determines the behavior of Desktop when it receives a work item that the program you are configuring generates.</p> <ul style="list-style-type: none"> <li>• <b>0 - No action.</b> Call Center Elite Multichannel Desktop makes the contact information available to the agent. The agent initiates contact when ready.</li> <li>• <b>1 - Preview Contact.</b> Reserved for future use. If used, this option follows the behavior of 0 - No action.</li> <li>• <b>2 - Initiate Contact.</b> Desktop displays the contact information to an agent and automatically initiates</li> </ul>

*Table continues...*

Name	Description
	a call using the dial delay time specified in the <b>Auto dial delay (seconds)</b> parameter.
<b>Auto dial delay (seconds)</b>	The number of seconds Desktop waits after an agent receives a work item from a program. After the specified seconds, Desktop automatically dials a first number in the contact details. The default value is 20.
<b>Client window title</b>	The text that the system displays on the title bar of a Preview Contact work item window.
<b>CC Elite Outbound tab</b>	
<b>Available for outbound work</b>	An option that determines the state of an agent for an outbound work.
<b>Type of outbound work</b>	The type of an outbound work for an agent.
<b>Interaction ignored by AS client</b>	The check box to ignore the interactions of the current program.
<b>Associated program list</b>	A list of associated programs.
<b>Customized Configuration tab</b>	
<b>Key</b>	<p>The name of the associated data.</p> <p> <b>Note:</b></p> <p>This is the additional customer data that the system displays in a work item that agents receive.</p>
<b>Value</b>	<p>The value of the associated data.</p> <p> <b>Note:</b></p> <p>This is the additional customer data that the system displays in a work item that agents receive.</p>
<b>Topic</b>	<p>The optional topic to be used as a subgroup.</p> <p>This is the additional customer data that the system displays in a work item that agents receive.</p> <p> <b>Note:</b></p> <p>You can add the following key value pair that enables the system to correctly identify all <b>Microsoft Dynamics CRM</b> activities and route the activities to Call Center Elite Multichannel Desktop through the Microsoft Dynamics CRM GUI Plug-in.</p> <p><b>Key:</b> Work Item Type</p> <p><b>Value:</b> 100</p>

## Assigning a schedule to a program

### About this task

You can assign a schedule to a program to automatically run the program at a specified schedule. You can also assign more than one schedule to a single program.

After you assign a schedule to a program, the system automatically runs that program once, daily, or weekly. You can also specify time in a schedule.

### \* Note:

In Call Center Elite Multichannel, only one instance of a program schedule is active at a time. If the schedules of two programs overlap each other, the schedule that starts first takes the priority and the system ignores the other overlapping schedule.

### Procedure

1. Start Call Center Elite Multichannel Control Panel.
2. In the left pane, expand the **Database Management** node.
3. Expand the **Media Store Database** node.
4. Expand a specific database node.
5. Expand the **Programs** node.
6. Right-click a program node and click **Assign Schedule**.
7. On the **Assign Schedule** tab, enter appropriate values in the fields.
8. Right-click anywhere on the **Assign Schedule** tab and click **Save And Close**.

### Related Links

[Assign Schedule field descriptions](#) on page 114

## Assign Schedule field descriptions

Name	Description
<b>Schedule ID</b>	The field to select a schedule you want the program to use.  For more information about creating a schedule, see <a href="#">Creating a schedule</a> on page 105
<b>Resume type</b>	The field to select a behavior for the program when the program restarts at the selected schedule: <ul style="list-style-type: none"> <li>• <b>0-Resume</b>: The program restarts from the point where it stopped and stops when it is finished.</li> <li>• <b>1-Restart</b>: The program restarts from the beginning and stops when it is finished.</li> </ul>

*Table continues...*



Name	Description
	<ul style="list-style-type: none"> <li>• <b>2-Resume Restart:</b> The program restarts from the point it stopped, finishes, and restarts after it finishes.</li> </ul>
<b>Preview Contact Media Store</b>	
<b>Media director managed by control panel</b>	<p>Lists the media directors.</p> <p>Select the required media director to populate the drop-down list for Media director queue id.</p>
<b>Media director queue ID</b>	The Media Director queue ID for the Preview Contact work items.
<b>Queue priority</b>	The priority of queuing work items.

---

## Adding a queue to Media Director

### About this task

Using this procedure, you can add a queue to the Media Director configuration.

### Procedure

1. Start Call Center Elite Multichannel Control Panel.
2. In the left pane, expand the **Media Directors** node.
3. Expand the **Media Director** node.
4. Right-click the **Queues** node and click **Add Queue**.
5. On the **Add Queue** tab, enter appropriate values in the fields.
6. Right-click anywhere on the **Add Queue** tab and click **Save And Close**.
7. Right-click the node for a queue and click **Start Queue**.

### Related Links





[Add Queue field descriptions](#) on page 132

---



## Add Queue field descriptions

Name	Description
<b>Queue ID</b>	Unique identifier for a queue.

*Table continues...*

Name	Description
	<p> <b>Note:</b></p> <p>Do not include spaces between words. Use an underscore (_) to join words, for example, Queue_1</p>
<b>VDN</b>	<p>The Vector Director Number (VDN).</p> <p> <b>Note:</b></p> <p>A VDN must be unique for each queue.</p> <p>Communication Manager dials the VDN to add phantom calls to the skill queue. For example, VDN = 9830.</p> <p>Click the ellipses (...) button next to this field to select a VDN from the available VDNs in Communication Manager.</p>
<b>Phantom station DN list</b>	<p>In the <b>Phantom station DN list</b> field, you can enter a phantom station.</p> <p> <b>Note:</b></p> <p>Phantom station must be unique for each queue.</p> <p>You can enter multiple phantom stations by separating them with a comma. For example, 4500-4509,4510,4511. You can click the button next to this field to select phantom stations configured in Communication Manager.</p> <p>Communication Manager uses the specified phantom stations as originating points for the phantom calls, in a queue that you specify</p>
<b>Phantom call UUI</b>	<p>In the <b>Phantom call UUI</b> field, you can enter the text that Media Director displays to an agent when Media Director generates a phantom call.</p> <p>Default: PHANTOM_CALL. With the default value, the system informs an agent that the call is a phantom call</p>
<b>Maximum queued work items</b>	<p>The maximum number of work items that you want the system to keep waiting in a queue.</p> <p> <b>Important:</b></p> <p>If the maximum limit exceeds, Media Director returns an error to Media Store. If you set an invalid value, which is out of the 1 to 100 range or a fractional value, the system sets the default value to 100.</p>

*Table continues...*

Name	Description
	<p> <b>Note:</b></p> <p>To use the preferred agent functionality of Call Center Elite Multichannel, set the maximum limit to at least 100.</p>
<b>Maximum queued phantom calls</b>	<p>The maximum number of phantom calls that you want the system to keep in a VDN queue.</p> <p> <b>Important:</b></p> <p>If you set an invalid value, which is out of the 1 to 100 range or a fractional value, the system sets the default value to 100.</p>
<b>Dial phantom call when no clients</b>	The check box to generate phantom calls when there is no Desktop application connected to Media Director.
<b>Enable preferred agent</b>	<p>The check box to add work items to a queue of preferred agent that you set in a media store database.</p> <p>If you clear this check box, work items are added in the queue of an agent who logs into a skill.</p>
<b>Refuse work item when monitoring queue failed</b>	The check box to refuse the work items when monitoring queue fails.

## Configuring Preview Contact Media Store

### Before you begin

Ensure that you have installed Preview Contact Media Store. For instructions on how to install Preview Contact Media Store, see *Installing Avaya Aura® Call Center Elite Multichannel*.

### Procedure

1. Start Call Center Elite Multichannel Control Panel.
2. In the left pane, expand the **Preview Contact Media Stores** node.
3. Right-click the **Preview Contact Media Store** node and click **Edit**.
4. On the **Edit Preview Contact Media Store** tab, enter appropriate values in the fields.
5. Right-click anywhere on the **Preview Contact Media Store** tab and click **Save And Close**.

## Edit Preview Contact Media Store field descriptions

Name	Description
<b>Media Director</b>	
<b>Media Director</b>	The Media Director server name.
<b>URL</b>	The URL that EMS uses to connect to the Media Director server.  The system forms this URL using the values that you specify in the IP, Port, Channel type, and URL fields.
<b>IP</b>	The IP address of Media Director.  The system automatically adds the IP address or host name of the Media Director server when you select a Media Director in the <b>Media Director</b> field.
<b>Port</b>	The port number to access the Media Director server. The default port number is 29087.
<b>Channel type</b>	The .Net remoting channel that the multimedia applications in Call Center Elite Multichannel use to communicate.  Default: gtcp.
<b>URI</b>	The Uniform Resource Identifier (URI) of the remote communication object factory on the Media Director server.  Default: RemoteFactory.rem.
<b>Error Logging</b>	You can enter the field values as mentioned in <a href="#">Error Logging</a> on page 339.
<b>Media Store Database</b>	
<b>Server name</b>	The server name on which you have configured the media store database.
<b>Database name</b>	The database name that you have configured for EMS.
<b>User name</b>	The user name to access the selected database.
<b>Password</b>	The password to access the selected database.
<b>Connection string</b>	The connection string based on the server and database you select.
<b>Test Connection</b>	A button to test if you can connect to the selected database on the selected server.

# Chapter 10: Media Store database

The Media Store database is used to store information related to different media that are used to communicate with customers.

## Related Links

[Configuring the Call Center Elite Multichannel databases](#) on page 23

---

## Deploying report files

### Before you begin

Before you start deploying report files, ensure that:

- Call Center Elite Multichannel services are installed on Windows Server.
- Database Server contains ASMSControl and ASContact databases of Call Center Elite Multichannel.
- Reporting server is maintained.

### About this task

To deploy or overwrite Call Center Elite Multichannel report files, you can use Database Utility-Reporting Files Deployment Agent.

### Procedure

1. Click **Start > All Programs > Avaya Aura CC Elite Multichannel > Desktop > Avaya Aura Call Center Elite Multichannel Control Panel**.
2. In the left pane, right-click the **Database Management** node and click **Deploy Reporting Files**.
3. On the **Database Utility-Reporting Files Deployment Agent** tab, perform the following steps:
  - a. In the **Report definition folder location** field, enter the location of the Call Center Elite Multichannel Reports folder.  
  
By default, the Reports folder is present in the directory path of Call Center Elite Multichannel Control Panel.
  - b. In the **Reporting service URL** field, enter the URL of the Reporting Server.

The format for the URL of the Reporting Server is `http://<Enter IP Address or Machine Name>/ReportServer/ReportService2005.asmx`.

- c. In the **Shared data source name** field, enter the name of data source that Reporting Service uses.

The default value for this field is `ASCCEReportingDS`.

- d. In the **Shared data source connection string** field, enter the connection string of the Reporting Database

The format for the connection string is `Data Source=<Enter Database Server Name>; Initial Catalog=ASMSControl`.

- e. In the **User name** field, enter the user name for the database server.

The default value for this field is `ASMSControl`.

- f. In the **Password** field, enter the password for the database server.

The default value for this field is `CCEUser0`.

- g. In the **Report Server User name** field, enter the user name for the Report Server.

- h. In the **Report Server Password** field, enter the password for the Report Server.

- i. In the **Report Server Domain** field, enter the domain name or IP address of the Report Server.

- j. Select the **Overwrite reports** check box, if the reports already exist.

If you select this check box, the utility can overwrite existing reports.

- 4. Click **Deploy**.

After the deployment is complete, the **Status** field displays the completion status.

- 5. On the agent side, click **Start > All Programs > Avaya Aura CC Elite Multichannel > Desktop > Avaya Aura Call Center Elite Multichannel Reporting**.

- 6. Click **Tools > Options**.

- 7. Click the **Reporting** tab and perform the following steps to configure the fields:

- a. In the **Report Server Scheme** field, keep the default value as `http://`.

- b. In the **Report Server Address** field, enter the machine name or IP address of Reporting Server.

- c. In the **Report Service Url** field, keep the default value as `ReportServer`.

- d. In the **Report Web Service Url** field, keep the default value as `ReportServer/ReportService2005.asmx`.

- e. In the **Report Generation Timeout (Seconds)** field, keep the default value as `600`.

- f. In the **User name** field, enter the user name of the server that hosts the Microsoft SQL Server Reporting Services.

- g. In the **Password** field, enter the password of the server that hosts the Microsoft SQL Server Reporting Services.
  - h. In the **Domain** field, enter the domain name or IP address for the Reporting Server.
8. After the configuration is complete, click the **Report Selection** tab to view reports.

---

## Outbound programs for virtual agents

You can use the Virtual Agent service to perform tasks without involving agents. The Virtual Agent service depends on the configuration of the worker plug-ins.

You can use the Outbound Worker plug-in to send emails or text messages to customers through a group of virtual agents.

You can send bulk emails or text messages to customers without involving agents, but only after you configure the following media stores:

- **Preview Contact Media Store:** This media store carries the customer data and the outgoing message to Media Director.
- **Email Media Store:** This media store sends the email message to a customer.
- **Simple Messaging Media Store:** This media store sends the text message to a customer.

After you configure the media stores, the program runs at the scheduled time.

### Important:

For the Outbound emails, the Virtual Agent service uses the Reply email address configured as the From address. Therefore, to use the Virtual Agent service along with the authentication configured in the Outbound queues, you must access your exchange server and configure **Manage Send As Permission** for a user other than the SMTP user configured in the **Outbound** tab. To configure **Manage Send As Permission** in Microsoft Exchange Server, see <http://technet.microsoft.com/en-us/library/bb676368%28v=exchg.141%29.aspx>.

### Related Links

[Creating an outbound program for email or simple messaging Media Store](#) on page 217

[Creating an outbound program for Preview Contact Media Store](#) on page 215

---

## Creating an outbound program for Preview Contact Media Store

### About this task

To create a program to send contact data to a virtual agent, use the following procedure:

### Procedure

1. In the **Database Management** node, expand the **Media Store Database** node.
2. Expand the database node for which you want to create an outbound program.

3. Right-click the **Programs** node and click **Add Program**.  
The system displays the **Add Program** tab.
4. In the **Name** field, enter the name for a program.
5. In the **Description** field, enter the brief description for a program.
6. In the **Used by** field, select the **Preview Contact Media Store** check box.
7. On the **CC Elite Configuration** tab:
  - Click the **Program access mode** arrow and select **Public**.
  - Keep the default values for other fields.
8. Click the **Customized Configuration** tab to configure outbound automated simple messages and outbound automated emails.
9. Right-click the **Add Program** tab and select **Save And Close** to save the information.

The system enables the new program. You can view this program in the Interactions node for the Preview Contact Media Store connected to the ASMediaStore Database.

**Related Links**

[Key Value pairs for sending automated simple messages and emails for Preview Contact Media store](#) on page 216

[Add Program field descriptions](#) on page 111

**Key Value pairs for sending automated simple messages and emails for Preview Contact Media store**

Name	Description
<b>Automated simple messages</b>	
<b>Service Name</b>	A remote service name that you want to use. Expand the <b>Remote Services</b> node for the gateway that you have configured in Call Center Elite Multichannel.
<b>Outbound Program ID</b>	A program ID of an outbound program that the Simple Messaging Media Store uses to send a message.
<b>Message</b>	A message that you want to send to the customers.
<b>Automated emails</b>	
<b>Service Name</b>	—
<b>Outbound Program ID</b>	A program ID of an outbound program that the EMS uses to send a message.
<b>Message</b>	A message that you want to send to customers.



---

## Creating an outbound program for email or simple messaging Media Store

### About this task

To create a program to send automated emails or simple messages to a customer:

### Procedure

1. In the **Database Management** node, expand the **Media Store Database** node.
2. Expand the database node for which you want to create an outbound program.
3. Right-click the **Programs** node and click **Add Program**.

The system displays the **Add Program** tab.

4. In the **Name** field, enter the name for a program.
5. In the **Description** field, enter the brief description for a program.
6. In the **Used by** field, clear the check box, if selected any.
7. On the **Configuration** tab:

- Click the **Program access mode** arrow and select **Public**.
- Keep the default values for other fields.

For detailed field descriptions, see [Add Program field descriptions](#) on page 111.

8. Click the **Customized Configuration** tab and add the following key value pairs:
  - Key=Service Name, Value=None, Topic=None
  - Key=Outbound Program ID, Value=None, Topic=None
  - Key=Message, Value=None, Topic=None
9. Right-click the **Add Program** tab and select **Save And Close** to save the information.

---

## Customizing multimedia work items by adding work forms

### About this task

You can add more than one additional work form to multimedia work items that a program uses. You can access the work forms using the additional tabs that the system displays at the side of the work item.

If you create more than one tab for a work item, you can configure the order in which you want the system to display the work forms.

To add a new work form to a multimedia work item:

## Procedure

1. In the **Database Management** node, expand the **Media Store Database** node.
2. In the specific database node, expand the **Programs** node.
3. Expand the specific program node to which you want to add a work form.
4. Right-click **Form** and click **Add Form Controls**.

The system displays the **Form Designer** tab.

5. In the right panel, select the required UI control from the list box that lists the UI element controls.
6. On the form, click where you want the system to display the selected UI control.
7. Perform the following steps in the properties panel below the UI controls list box:
  - a. In the **Text** field, in **Appearance** node, enter the name of selected UI control.
  - b. In the **Name** field, in **Misc** node enter the text that you want the system to display on the work item tab.
  - c. Enter the appropriate values in other fields.
8. Repeat the Step 5 on page 218 through Step 7 on page 218 to add all the required UI controls and complete your form.
9. Right-click the **Form Designer** tab and select **Save And Close** to save the information.

The system adds the form in the **Forms** node with a name:

Form <order of form creation>.

---

## Reordering the forms controls

### Procedure

1. In the **Database Management** node, expand the **Media Store Database** node.
2. In the specific database node, expand the **Programs** node.
3. Expand the specific program node to which you want to add a work form.
4. Right-click **Form** and click **Reorder Form Controls**.

The system displays the **Reorder Forms** tab.
5. From the list of forms, select a form that you want to move up or down and use the required arrow key.
6. Right-click the **Reorder Forms** tab and select **Save And Close** to save the information.

 **Note:**

The order in which you created the forms remains same. The order in which the system displays the forms changes.

# Chapter 11: Contact database

ASContact Database is the repository in Avaya Aura® Call Center Elite Multichannel to store all contact information.

Call Center Elite Multichannel uses ASContact Database to identify people and to understand how to communicate with people. Call Center Elite Multichannel refers to ASContact Database for all contact-focused activities, no contact specific data is held elsewhere in Call Center Elite Multichannel. Instead, other Call Center Elite Multichannel databases hold a contact ContactId of contact to link contact data in ASContact Database. A ContactId is a key that uniquely identifies a contact within and beyond Call Center Elite Multichannel.

ASContact Database comes with a Contact Gateway for organizations that prefer to store the contact data in databases external to Call Center Elite Multichannel. Contact Gateway points directly to external data, and then use it as if it were its own. In this mode Call Center Elite Multichannel never updates the external data. However, once the gateway is in place, the external data participates fully as contact data within Call Center Elite Multichannel.

ASContact Database provides all features of the earlier ActiveContact database in Call Center Elite Multichannel, and more. Use the migration script to move existing contact data in ActiveContact Database to ASContact Database.

As ASContact database accumulates history and detail about its contacts, Call Center Elite Multichannel increasingly offers communication tailored specifically to contact preferences.

---

## Contact overview

In the ASContact Database, a contact is any person or group of people that can interest your organization or Call Center Elite Multichannel. A contact usually can be a customer, a prospect, an employee, an agent, or anyone else.

The ContactId which is any character string up to 100 characters long uniquely identifies a contact. If you use ASContact Database to store your contacts then it automatically generates a globally unique identifier (GUID) in a 36 character string format as the ContactId to establish uniqueness. An example of an ASContact Database ContactId is: 3F2504E0-4F89-11D3-9A0C-0305E82C3301

However, if ASContact Database uses a gateway view to an external database, this 100 character string can contain anything. All ASContact Database requires is that each contact has a uniquely different ContactId from every other contact.

The Contacts table in ASContact Database has many fields that contain information about the contact. However, these fields are not restrictive. If you choose to use external gateway, the data you hold on a contact can be different. Even if you use Contacts table of Call Center Elite Multichannel, you have considerable flexibility in changing or adding to the data which you hold for a contact.

---

## Contact Gateway

Contact Gateway is the way by which ASContact Database views its contact data. In technical terms we use the Contacts\_GW view in the ASContact Database to link to the data that we can use for contacts.

You can use ASContact Database to store your contact data by using any of following methods:

- Inputting data as required using Call Center Elite Multichannel Control Panel
- Importing an existing database into ASContact Database. The advantages of having ASContact Database store your data is that you can easily use Call Center Elite Multichannel to store and update contact data. You do not need anything else. This is particularly attractive if you do not already have an established contact database. If you keep contacts in the earlier ActiveContact database of Call Center Elite Multichannel, use the script provided, that is, Convert ActiveContact Contacts to ASContact Database.sql to import this data into ASContact Database.

If you already have a good operational contact database, together with effective ways to maintain this contact data, you can instruct ASContact Database to use this database.

Point ASContact Database to the data, which can be any database that SQL Server connects to using ODBC or other connectors, by modifying the ASContact Database Contacts\_GW view. The way you access contact data can be complex. You can also combine several external contact databases with ASContact Database internal contact data.

If your existing data is held in a Microsoft Dynamics CRM database, Call Center Elite Multichannel provides a ready-to-use gateway that links directly to Microsoft Dynamics CRM.

Even if you link to any external database, you can use all ASContact Database's facilities; including searching, grouping, permissions and associated data. But what you cannot do is use Call Center Elite Multichannel to add new contacts or change existing contact data. Call Center Elite Multichannel can only do that with data held in its own Contacts table.

---

## Groups

Any contact can also be a group that has other contacts as members. For example, a contact who is a manager can be defined as a group, with staff as members of the group. A group, such as the

manager, is also a contact simultaneously. In most operations, ASContact Database uses contacts, group contacts and member contacts interchangeably.

Any number of group levels can be created, and a contact can belong to any number of groups. Also, a contact can be a member of a group which it 'owns' at some higher level.

Keep the levels of grouping as low as possible to help Call Center Elite Multichannel users clearly understand the grouping structure. Three or four levels of groups must cover most scenarios without becoming too complex.

This ASContact Database directory contains several groups which are indicated by the blue background.

First Name /	Last Name	Business	Mobile	Home	Work Fax	Email
Derek	Mittendorff	8554	462 292	477 0554		
Development Group						
Gary	Doherty	8641				
George	Sampson	+64 (9) Business	+64 (21) Mobile	+64 (9) Home	+64 (9) Busine:	
Ghee	Chew					ghchew@avaya.cc
Holger	Barth					hbarth@avaya.com
Jack	Frank	(09) 419 5019	+64 (21) 266 1938			
Joe	Chau					jtchau@avaya.com
Kasey	Keller	8911				
Lars	Hirschfeld	8867				
Luiz	Barbosa	8566		477 0566		
Mark	Vincent	8561	021 924 944	477 0561		

You can view a list of associated contacts, by double-clicking the group.

ASContact Database keeps information on groups and members in the GroupMembers table of ASContact Database. Groups and members are represented by the contact keys that is, ContactId only. The groups can work with external databases by the ContactId. Moreover, the time when group membership begins and ends for each contact is kept. Information about group membership usually never lost, and possible to follow group membership over time.

In the future ASContact Database can understand special groups of contacts, for example, agents, past agents, employees or customers. ASContact Database can find the ContactIds of these special groups in the configuration data of ASContact Database.

### Related Links

[AssociatedData](#) on page 225

---

## Search capability

Operators can search for and display contacts from ASContact Database using the Directory Plug-in. The way the search operates depends on the type of field from the contact record that you search on.

On receipt of a new incoming message, media stores execute automatic searches in ASContact Database based on the incoming address data. For example, the voice media store does a search

on all phone numbers held in ASContact Database to view if one matches with the incoming phone number. Email and Simple Messaging Media Stores conduct similar searches on their incoming addresses.

To help both operator-initiated and automatic searches, ASContact Database rates the likelihood of an address in its database by being the address you are searching for and displays this as a rating with other contact data.

## Related Links

[Rating](#) on page 226

---

## PhoneLookUp

Call Center Elite Multichannel Desktop introduces PhoneLookUp, a subsystem within ASContact Database that quickly finds a contact given in their phone number.

The contacts can have a large and variable number of phone numbers. Using normal methods, searching a large Contact database can be slow. This is especially noticeable when a media store wants to instantly identify a contact based on an incoming phone call. Using PhoneLookUp, ASContact can identify contacts within 40 milliseconds when searching a database containing 10 million phone numbers.

The PhoneLookUp subsystem maintains an extra PhoneLookUp table that holds phone numbers from the Contacts GW view in a way that facilitates fast access.

Although it works most easily when the Contacts table of Call Center Elite Multichannel is used, with a little extra effort external contact databases can also take advantage of the PhoneLookUp subsystem.

Usually the phone number to match comes from a Caller Line Identification feature of a telephony switch. The format and completeness of CLI varies by location and local PSTN conventions.

Sometimes it includes the local Area and country codes, sometimes not. Therefore, ASContact Databases phone lookup feature matches the input phone number exactly that is, to the same number of digits, if possible. If the input phone number does not match, it then matches on numbers in the database with the same base number together with additional Area and country codes. An incoming number of 409-5498 can match a database number of (603) 409-5498 when the database does not contain a phone number of 409-5498 exactly. Similarly an incoming number of (603) 409-5498 can match a database number of +61 (603) 409-5498 when (603) 409-5498 does not appear in the database.

---

## ASContact Contacts table

If you use ASContact Contacts table, the PhoneLookUp table automatically synchronizes with phone number data in the Contacts table as contacts are created, modified, and deleted. Triggers

on the Contacts table call the MaintainPhoneLookup stored procedure to propagate Contacts phone number field changes to the PhoneLookup table.

If, you already have an existing ASContact Database, use the BuildPhoneLookup stored procedure to create a new PhoneLookup table based on your existing data. Usually you must do this only once after upgrading ASContact, the first containing the PhoneLookup feature. However, you can run BuildPhoneLookup more than once as it first removes all entries from the PhoneLookup table before rebuilding it.

ASContact retains the present flexibility to treat any fields in the Contacts gateway view as phone number fields. After any reassignment of phone number fields in the Contacts table, you must run BuildPhoneLookup again after which the triggers automatically handle things according to the new assignments.

---

## Media Store permissions

Media stores have a new way to find if and how media stores must process a message for a contact.

At first, ASContact Database establishes the contact who owns the message by using an automatic search. ASContact Database then discovers what permissions that contact has for the particular program. There are tests available at different levels. For example, the contact does not have a specific permission, but belongs to a group that does. Similarly, there cannot be a specific permission for the program receiving the message, but there can be permission for the media store type. For example, email to fall back on.

Finally, there is default processing if permissions are unavailable at any level.

---

## Permission options

The MediaStorePermissions table in ASContact Database governs which contacts can access which programs. The ContactId and MediaStoreEntityId fields determine whether a row in the MediaStorePermissions table is applicable for a situation. The MediaStoreEntityId field is a multipurpose field that contains the GUID for a program (ProgramId), a specific media store (ServerInstanceId), or a class of media stores (ServerInstanceType).

ASContact Database uses the GetMSPermissionsForContact stored procedure to find the best Permission row for a given combination of ContactId and MediaStoreEntityId fields, matching in order of preference:

- For a ProgramId and the contact, or a group that the contact belongs to, the following is the order of priority:
  - Permission for a contact.
  - Permission for a group in which the contact is a level 1 member.
  - Permission for a group in which the contact is a level 2 member.

- For a `ServerInstanceId` and the contact, or a group that the contact belongs to, the following is the order of priority:
  - Permission for a contact.
  - Permission for a group in which the contact is a level 1 member.
  - Permission for a group in which the contact is a level 2 member.
- For a `ServerInstanceType` and the contact, or a group that the contact belongs to, the following is the order of priority:
  - Permission for a contact.
  - Permission for a group in which the contact is a level 1 member.
  - Permission for a group in which the contact is a level 2 member.

A permission row is accepted only if the overall rating assigned to the contact is greater or equal to the `OverallRating` field of the Permission row. For example, an `OverallRating` field of 100% specifies that the permission applies only to a contact that is uniquely identified as an individual. However, an `OverallRating` field of 80% identifies the contact as a member of a domain group from an incoming email address.

**\* Note:**

Media stores use the `ValidateContactForProgram` procedure to identify the contact using `FindContactsForAddress`. After identifying the contact, the `ValidateContactForProgram` procedure passes the `ContactId` and media store data to the `GetMSPPermissionsForContact` procedure to get permissions.

If multiple rows with equal preference exist, the `PermissionRank` field determines the rating of the rows. The row with lower rank has a higher rating.

After ASContact Database selects the row with highest rating, the permission is granted based on the mode of operating program. If the operating program is public, permission is granted unless specifically denied (`Permission=0`). If the operating program is private, a row must grant permission (`Permission=1`).

If permission is granted, the facilities such as a change of program, change of priority, and preferred agent can be activated for the interaction.

**\* Note:**

A contact can have a permitted row defined for a public program, so that the contact reaches for a preferred agent. Similarly, a contact can have a denied row for a private program so that the contact receives a denied notification message.

To get the right permission structure for your organization, use the following approach:

- Set the permission for the default group. The default group does not have entry in the permissions table. The group has entry in a public program and denied from a private program.
- Set the least specific level of permission for a media store type entered as `MediastoreEntityId`. This act as a backstop if no specific permission is available. Typically, you must use the media store type with a `ContactId` representing general groups.



- Set the permission for a specific media store. This level of permission is for future use, as the current installations have only one media store of a specific type.
- Set the most specific level of permission using a ProgramId as the MediaStoreEntityId. To minimize maintenance, you can use groups for ContactId. For important contacts, you can have separate entries for the contacts for each program.

To validate permissions, a fair processing occurs. In future, Call Center Elite Multichannel Control Panel can have the facility for an administrator to view the search result of the permissions table for any ContactId, ProgramId, ServerInstanceId and ServerInstanceType combination. Currently, the results can be viewed by using SQL Server to run the GetMSPermissionsForContact stored procedure. GetMSPermissionsForContact returns the permissions found with the exact ContactIdMatched and MediaStoreEntityIdMatched. ContactIdMatched can be a group where the input ContactId belongs to and MediaStoreEntityIdMatched is a program, media store, or media store type.

The permissions system uses the contact key (ContactId) to operate, therefore, the permissions system also works for contacts that reside in an external database.

---

## AssociatedData

ASContact Database contains a table of AssociatedData. This is a process to save extra data, which is not covered by existing fields in the database. For example, notes that are an accumulation of your call center experience with a particular contact.

Each row of data in the table is stored with:

- An AssociatedId as a key. Typically this is the ContactId of an existing contact.
- A key which is a description of the data, such as “Preferred Travel Agency”.
- The value for this key for this contact, such as “Book it Cheap, Book it Now”.
- An optional topic that can relate this key with other keys.

For example ASContact Database uses AssociatedData to store the User name and Password (keys) for DomainCredentials and WebCredentials (Topics).

Notionally Keys qualified by Topic if exists, displays as extra column names, with the corresponding values providing the data content of the column.

In case of customizing, Call Center Elite Multichannel writes special purpose plug-ins and stores any extra data for a contact as AssociatedData. If this is considered as a permanent part of the contact data, then customize Contact Gateway includes particular AssociatedData as an extra contact field. Alternatively, AssociatedData displays the data as a field in a display view on an ad hoc basis, without formally including it in Contact Gateway.

### Related Links

[Media Store permissions](#) on page 223

---

## Rating

When you search contacts, ASContact Database lists those contacts that matches fully or partially the search criteria. Rating is an assessment, expressed as a percentage of how closely ASContact Database understands the data that ASContact Database has for the contact matches in the search criteria.

For example, if you search for John Brown by name, and ASContact Database holds two contacts with a names of John Brown and John Brownly, the rating of the John Brown is 100% and the John Brownly is 83%.

Rating assesses how closely one contact, considered in isolation, matches your search criteria. Rating takes no notice of other contacts that also match the same criteria, either more, or less closely.

Contacts display based on rating from best to worst match.

---

## Overall rating

When, Call Center Elite Multichannel searches contacts in automatic mode that is, without operator assistance, ASContact Database calculates an overall rating for a contact. This is a weighted average of a contact rating with that of all other contacts that matched partially. ASContact Database uses overall rating as the probability of a contact that you are searching.

For example, you search for John Brown by name and ASContact Database holds two contacts with names of John Brown and John Brownly. If only these two records are found, ASContact Database gives John Brown an Overall Rating of 54%, while John Brownly gets 38%.

If a process needs a contact identified to a measurable degree, expressed as overall rating, and an automatic search finds a sole contact with the highest overall rating, then ASContact Database proceeds with this contact.

As the overall rating is used internally, it is not displayed. You can customize search ratings within ASContact Database.

### Related Links

[Customize searches](#) on page 232

---

## Database configuration

ASContact Database stores the configuration data in the database using AssociatedData, which is stored in the GUID (44B9249D-B7EA-4155-A08B-8CDC8FE4991D) with the Topic "AS Contact Configuration". The DBConfigurationValue function extracts the value of a configuration item based on the given key.

---

## Identification and searches

All searches, except by name, scan only the contact columns that match the type of the data that is searched for using the FindContactsFromAddress stored procedure. More sophisticated searches can require that:

- Contacts must be included in or excluded from a specific group.
- Contacts are associated with a given switch.
- Contacts are validated by a specific matching function.
- Contacts must have a minimum rating.
- Contacts must have a rating that differs from the contact with the best rating by no more than a certain percentage.

Searches by name can scan both the FirstName and LastName fields, depending on input parameters. If parts of both names are input, then names containing both the names are returned. If a part name to search for begins with an uppercase letter, only then names beginning with the part name matches. Input of additional input parameters to the FindContactsFromName stored procedure leads to more sophisticated searches as for FindContactsFromAddress.

---

## Gateway view modification

---

### Creating a link to an external server

#### About this task

Before modifying the view to access your proprietary data, you must create a link to the external server that contains the data.

If you are using Microsoft SQL Server Management Studio (Express), you can use this procedure to create a link to an external server.

#### Procedure

1. Right-click **Server Objects > Linked Servers**.
2. Follow the instructions to create a link.

 **Note:**

External data source can be any database type accessible by Microsoft SQL Server.

3. After you create a link, modify the **FROM** clause to address your external database:

```
FROM ServerName.DatabaseName.dbo.TableOrView ... JOIN ON ...
```

**\* Note:**

The custom view is the result of complex external table joins or the UNION of multiple SELECT statements, that is contacts can be collected together simultaneously from multiple databases for Call Center Elite Multichannel use. The field designated as ContactId from all various sources must be unique.

---

## Modifying the gateway view

### About this task

If you are using Microsoft SQL Server Management Studio (Express), you can use this procedure to modify the gateway view.

### Procedure

1. Click **Script View as > ALTER to > New Query Editor Window.**

The system displays the construction of the gateway view.

Microsoft SQL Server is sensitive to collations that is, how Microsoft SQL Server ranks data when comparing strings.

2. To avoid problems, code each line in your custom view as:  
`CAST(Zip AS NVARCHAR(255)) COLLATE database_default AS HomePostalCode.`
3. To include AssociatedData permanently in the view, add code to the view as:  
`(SELECT TOP 1 CAST([Value] AS NVARCHAR(4000)) FROM AssociatedData.`

In this case, AssociatedId=Contacts.ContactId AND [Key]="UserName"AND Topic="DomainCredentials"ORDER BY Id DESC) AS [DomainUserName].

This above line from the default view formats a field called DomainUserName from the latest piece of AssociatedData stored for the contact with the "UserName" key under a topic of "DomainCredentials".

---

## ASContact database customization

---

### The gateway view

Call Center Elite Multichannel offers a gateway to contact databases using the concept of a gateway view named Contacts\_GW. All ASContact Database stored procedures and functions that retrieve contact data use this view.

The gateway view points either to the ASContact Database Contacts table or to an external source or sources. The major requirement of any source is that the source has a unique identifier, not more

than 100 characters long for each contact which is named as ContactId in the gateway view. Moreover, you must have fields as FirstName, LastName, and DisplayName defined in the view. If Call Center Elite Multichannel operates across multiple switches and you use SwitchId as search criteria, the contact data source must also have a field named SwitchId. No other field names are mandatory, and fields can be named as required.

Standard contact views are provided for using Contacts table of Call Center Elite Multichannel and Microsoft Dynamics CRM database as an external source. The default view is for the Contacts table of Call Center Elite Multichannel. If you want to use this unchanged, do not change. Choose Microsoft Dynamics CRM by commenting out the code referencing Contacts table of Call Center Elite Multichannel and remove the comment that references Microsoft Dynamics CRM in the view definition.

The gateway view also offers the ability to treat associated data, which is a mechanism to flexibly extend contact storage beyond predefined column names, as if it were a column in any contacts table.

The creation and update of contact data stored external to ASContact Database is left to the maintenance routines of those external systems. Call Center Elite Multichannel provides maintenance routines only for contacts stored in ASContact Database Contacts table.

The other features of Call Center Elite Multichannel contacts handling work for all contacts, no matter where they come from, includes contact searches by address types, rating of selections, multi-grouping of contacts, customized display of contact columns, media store permission lists, and use of contact associated data.

---

## ASContact database data handling

ASContact Database needs some information about fields in the Contacts\_GW view, as external data can be of any type. With this knowledge, ASContact Database can intelligently handle the contact data.

ASContact Database uses the ColumnTypes, Contacts\_GWColumns, and Contacts\_GWColumnType tables to identify the fields in the contact view that it must search for a phone number.

### Related Links

[Contacts\\_GWColumns table](#) on page 230

[ColumnTypes table](#) on page 229

[Contacts\\_GWColumnTypes table](#) on page 231

### ColumnTypes table

The ColumnTypes table consists of predefined column types. For special purposes, you can add more column types to the table.

ColumnId	ColumnTypeId
1	Name
2	Voice
3	Email
4	URL
5	Post Code
6	Date
7	Yes or No
8	Fax Number
9	Text
10	Record key
11	First Name
12	Last Name
13	SMS
14	IM-MSN
15	IM-AOL
16	IM-ICQ
17	IM-Google
18	IM-Yahoo
19	Culture
20	Personal address
21	Other record key
22	Image
23	Unknown
24	Integer
25	Money
26	Username
27	Password
28	Float
29	SIP

## Contacts\_GWColumns table

The Contacts\_GWColumns table stores the names of all fields in the Contacts\_GW view with the column number of the field. ASContact Database automatically generates the Contacts\_GWColumns table after the Contacts\_GW view is finalized.

ColumnId	ColumnTypeId
1	ContactId
2	CreateDateTime
3	ModifyDateTime
4	CompanyContactId
5	AssistantContactId
6	ManagerContactId
7	Culture
8	CommunicationCulture

## Contacts\_GWColumnTypes table

The Contacts\_GWColumnTypes table specifies column types (ColumnTypeId) for each column (ColumnId). A column can have multiple column types. The type of data in a column is unknown for external data. Therefore, you must manually enter the column type information in the Contacts\_GWColumnTypes table to match the data correctly in your view.

However, ASContact Database optionally guesses a column type based on the name. This action can be a useful starting point from which you can manually update column types.

### \* Note:

You do not need to make any changes to the Contacts\_GWColumnTypes table if you use one of the default views of ASContact.

ColumnId	ColumnTypeId
1	10
2	6
3	6
4	21
5	21
6	21
7	19
8	19
....	....

## PhoneLookUp components

PhoneLookUp uses the following components for searching phone numbers.

The PhoneLookUp table contains:

- A phone number as held in the Contacts\_GW view, but stripped of all punctuations and inverted right to left for efficient indexing.
- The ContactId of the person that this phone number belongs to.
- The ColumnId of this phone number field within the Contacts\_GW view.

ASContact standard routine does the exact phone number look-up to find a contact based on any address type information by FindContactsFromAddress. FindContactsFromAddress automatically accesses the PhoneLookUp table when searching a phone number.

A new stored procedure MaintainPhoneLookUp keeps the PhoneLookUp table in synchronization with the data in the Contacts\_GW view. Triggers on the Contacts table call MaintainPhoneLookUp when they recognize a phone number field is changed.

BuildPhoneLookUp initially populates the PhoneLookUp table when the PhoneLookUp subsystem is added to an existing ASContact Database when converting from 3.0.2 to 3.0.3.

The stored procedures call the new functions FormatPhoneLookUp, CreateUpperPhoneLookUp, and FindUpdatedPhoneColumns as needed.

## Customize searches

ASContact Database deliberately isolates all search matching and rating into separate database functions with names beginning with "IsMatch...". These routines contain the rules of the exact match and decide how close a particular match is. All routines return a float number interpreted as the rating with a value between 0 for no match and 1 for a 100% perfect match.

You can modify these routines to suit the specialized purposes. You can go further and write an entire new "IsMatch" routine to handle new data types or to handle existing types differently.

The search stored procedure FindContactsFromAddress uses the IsMatch routines. Based on address data type, FindContactsFromAddress uses a default IsMatch routine. However, you can override this default behavior by passing it the name of a different IsMatch validation routine as the input parameter @AddressValidationFunction.

---

## PhoneLookUp table maintenance

---

### External database

ASContact has no direct knowledge about changes in phone number when you use an external database to store and maintain information of your contacts. In this circumstance, you must arrange for the external database to call MaintainPhoneLookUp of ASContact when necessary to keep the PhoneLookUp table updated with the latest phone number information.

If you have contacts in an external database, use the BuildPhoneLookUp stored procedure to create a new PhoneLookUp table based on the existing data. You must do this only once after upgrading ASContact to version 4.1.0.1, the first version containing the PhoneLookUp feature. However, you can run BuildPhoneLookUp more than once as BuildPhoneLookUp first removes all entries from the PhoneLookUp table before rebuilding it.

One possible way to maintain the PhoneLookUp table for an external database without online use of MaintainPhoneLookUp is to run BuildPhoneLookUp regularly. However, if you use



BuildPhoneLookUp the phone numbers in Contacts\_GW and PhoneLookUp can be exactly identical immediately after BuildPhoneLookUp runs. With a relatively stable contacts database this action can be perfectly acceptable.

ASContact retains the present flexibility to treat any fields in the Contacts gateway view as phone number fields. After any reassignment of phone number fields in your external database, you must run BuildPhoneLookUp again, and then update the database use of MaintainPhoneLookUp to reflect these changes.

---

## ASContact Database configuration

The Contact database stores the contact details of customers who contact the contact center and the people who work in the contact center.

The Contact database, named **ASContact**, is an SQL-based database. You can use this database as a directory to store and maintain the contact details of customers and people in a contact center.

The **ASContact** database offers a wide range of fields or columns to store detailed information of customers. The field structure of the database is based on the field structure of Microsoft Outlook.

When configuring this database, you can choose the fields that you want to use. To create or upgrade the **ASContact** database, see [Configuring Call Center Elite Multichannel databases](#) on page 23.

## Adding a new contact

### Procedure

1. On the **Database Management** node, expand the **Contact Database** node.
2. Expand a database node for the **ASContact** database.
3. Click the **Contacts** node.

On the right pane, the system displays the Contacts screen on the **Summary** tab.

4. On the **Summary** tab, right-click the contacts list and select **Add Contact**.

The system displays the **Add Contact** tab.

5. On the **General** tab, enter the appropriate values.

On this tab, you can change the field names for some of the fields. For example, in the **Phone numbers** section, you can click the arrow corresponding to the **Mobile** field and change the field name to **Home**.

### **Note:**

Enter complete information such as first name, middle name, last name, email address, and phone numbers. This action enables the system to find the details of a customer who contacts the contact center.

6. On the **Details** tab, enter the personal and family information of the contact in the appropriate fields.

7. On the main menu bar, click **File > Save** to save the contact details.

**\* Note:**

On the main menu bar, click **File > Save All** to save the updated information on all open tabs.

For more information about adding contacts, see *Avaya Aura® Call Center Elite Multichannel Desktop User Guide*.

## Format for contact phone numbers

To use the Smart Dial functionality, you must format the contact phone numbers as follows:

- Do not use Public Switched Telephone Network (PSTN), Subscriber Trunk Dialing (STD), or International Direct Dialing (IDD) access codes in the phone number.

PSTN is the code required to dial an outside line, STD is the code required to make a national call, and IDD is the code required to make an international call.

- Use either a single space, a hyphen, or parentheses to separate area codes from the local number.

For example, 3 4770576, 3-4770576, (3) 4770576, or (3)4770576.

- Prefix all country codes with +.

For example: +64 3 4770576, +64-3-4770576, +64 (3) 4770576 or +64(3)4770576

If you do not want to use the Smart Dial functionality, you must enter phone numbers exactly the way you dial them. You must include the PSTN, IDD, or STD access codes, the country codes, and the area codes with the phone number.

For example: 14770576, 103 4770576 or 10064 3 4770576.

---

## Contact groups

In the **ASContact** database, you can create a group of related contacts. This action helps an agent to quickly find information of a contact.

You can create different groups depending on the size and structure of the contact center. You can name a group according to a department or work area, or even a person, such as Manager or Administrator, and associate the related contacts to that group. You also add groups inside another group.

**\* Note:**

The contacts in a group remain as an individual record in the **ASContact** database, and the system displays this record in Directory. For more information, see *Avaya Aura® Call Center Elite Multichannel Desktop User Guide*.

In the Directory window, the system indicates:

- Each contact in black color with a contact icon and contacts with permissions in bold.

- Each group in blue color with a group icon and groups with permissions in bold.

You can double-click a group name to display the groups and contacts available in that group.

## Creating a group of contacts

### About this task

To create a group of contacts:

### Procedure

1. In the **Database Management** node, expand the **Contact Database** node.
2. Expand a database node for the **ASContact** database.
3. Click the **Contacts** node.

In the right pane, the system displays the Contacts screen on the **Summary** tab.

4. On the **Summary** tab:
  - a. Right-click a contact record and select **Manage Group**.  
The system displays the **Group Management** tab.  
The system associates the group to a contact that you select to create a group.
  - b. In the **Search target fields** section, click **Search** to display the contacts available in the **ASContact** database.
  - c. In the contact list, right-click the contact or group you want to add in a group and select **Add To Group**.  
The system adds the selected contact in the **Group members** list.
  - d. Right-click other contacts that you want to add in a group.
5. On the main menu bar, click **File > Save** to save the group.

## Deleting a contact from a contact group

### About this task

To delete a contact from a contact group:

### Procedure

1. In the **Database Management** node, expand the **Contact Database** node.
2. Expand a database node for the **ASContact** database.
3. Click the **Contacts** node.

In the right pane, the system displays the Contacts screen on the **Summary** tab.

4. On the **Summary** tab:
  - In the **Group members** list, right-click a contact that you want to delete from the group and select **Delete From Group**.

---

## Column display

ASContact Database holds many pieces of data for each contact. As some data are not immediately pertinent, you can choose the fields **ASContact Database displays** by selecting a predefined column display list. To view the contact from the contact view, you can select the fields. You can also change the field names by choosing your own column heading.

Using this facility, you can set up standard column display lists for staff groups depending on the function, or even use different display lists based on the task performed. For confidentiality reasons you can deliberately omit some fields from displays used by some staff.

With this display mechanism, you can display associated data belonging to the contact as a field contained in the contact view.

You can define a column display for the **ASContact** database. In the column display, you must add the fields such as FirstName and LastName to store information about a contact.

A column display list of zero has the special meaning of displaying all contact fields.

 **Note:**

Currently, some existing display capability is unavailable through Call Center Elite Multichannel Control Panel. To use AssociatedData, which is undefined as a contact field in Contacts\_GW view), you must manually modify data in the DisplayColumns table. You can name the column (ColumnName) to display as AD\_Key\_Topic by replacing Key and Topic with the exact keys and topics, available in the AssociatedData for the contact. ColumnDisplayName remains the displayed name for this field. In the ColumnTypeId column put the address types for this AssociatedData, separated by commas if more than one address type. Display routines search and display this data from AssociatedData rather than from the contact view.

### Related Links

[AssociatedData](#) on page 225

## Adding a column display

### About this task

To add a column display, perform the following steps:

### Procedure

1. In the **Database Management** node, expand the **Contact Database** node.
2. Expand a database node for the **ASContact** database.
3. Expand the **Column Display** node.

The system displays the default **Standard** column display.

**Standard** column display is added when you install the **ASContact** database.

4. Click the **Standard** node to display field details.

**\* Note:**

- You can modify the **Standard** column display, but you cannot delete the **Standard** column display.
5. Right-click the **Column Display** node and select **Add Column Display**.  
The system displays the **Add Column Display** tab.
  6. In the **General** section:
    - a. In the **Column display ID** field, enter the unique ID for a new Column Display.
    - b. In the **Column display name** field, enter the name of a new Column Display.
  7. Right-click the **Add Column Display** tab and select **Save And Close** to save the information.

## Adding columns to column display

### About this task

To add columns to a column display, perform the following steps:

### Procedure

1. On the **Database Management** node, expand the **Contact Database** node.
2. Expand a database node for the **ASContact** database.
3. Expand the **Column Display** node.
4. Right-click a column display to which you want add columns and click **Edit**.  
The system displays the **Edit Column Display** tab.
5. On the **Display field details** section, right-click and click **Add**.  
The system displays the **Add New Column** tab.
6. In the **Add New Column** tab, enter the appropriate values.  
For detailed field descriptions, see [Add New Column field descriptions](#) on page 237.
7. Right-click anywhere on the **Add New Column** tab and select **Save And Close** to save the information.  
The new column adds in the list of columns, which you can view on the **Edit Column Display** tab.
8. Repeat the procedure to add more columns.

### Add New Column field descriptions

Name	Description
Column order	The number that indicates the position of a column.

*Table continues...*

Name	Description
<b>Column name</b>	<p>The predefined column name that you want to use for this column.</p> <p>Use the drop-down list to select the predefined column name.</p>
<b>Display name</b>	<p>The display name for the column.</p> <p>By default, the system displays the default column name. If you want to use a different column name, change the value in this field.</p>
<b>Use the predefined types</b>	<p>The check box to change the default column type associated with your column.</p> <p>By default this check box is selected.</p>
<b>Column types</b>	<p>The column types that you want to associate with your column.</p> <p>This list of column types display, if the <b>Use the predefined types</b> check box is not selected.</p> <p> <b>Important:</b></p> <p>Associate column types with columns correctly as this association affects how Call Center Elite Multichannel Desktop interprets data. This association also affects the types of actions, an agent can perform using that data.</p> <p>Column type association determines whether Call Center Elite Multichannel Desktop searches that column for a contact match when a certain type of work item arrives.</p> <p>For example, if you associate the <b>Email</b> column type to a column, the system searches the data in that column when system receives an email work item. If the email address in an incoming email work item that matches with the address in the column, the system displays the corresponding contact details in a document window.</p>

---

## Permissions of a contact or a group of contacts

Call Center Elite Multichannel assigns an access mode to each program. The access mode is either public by which a work item is sent to a contact center agent, or private, which prevents a work item to send to a contact center agent.

You can use the Permissions option to change the permissions for an agent to access a particular program. You can also assign permissions to contact groups.

If the system does not find a contact in the database, or if the system finds a contact but without assigned permissions, Media Store checks the access mode of program that a queue, in which a work item is received, uses.

If the system finds a contact in the database with the assigned permissions, Media Store uses the permission settings and overrides any access mode assigned to the program.

For example, if you assign the public access mode to a program and select **Denied for Public Program** permission type for an agent, the agent does not receive the work items.

Similarly, if you assign the private access mode to a program and select **Allowed for Private Program** permission type for an agent, the agent receives the work items.

The permissions are applicable only for email and simple messaging work items. You cannot use permissions for Preview Contact work items.

## Assigning permissions to a contact or a contact group

### About this task

To assign permissions to a contact or a contact group, perform the following steps:

### Procedure

1. In the **Database Management** node, expand the **Contact Database** node.
2. Expand a database node for the **ASContact** database.
3. Select the **Contacts** node.  
On the **Summary** tab, the system displays the contacts available in the database.
4. Click **Search** if the contact list is empty.
5. In the Contacts list, select a contact to assign permissions.
6. In the **Permissions and Priorities** section, right-click the list and select **Add Permission**.  
The system displays the **Add Permission** tab.
7. On the **Add Permission** tab, enter appropriate values in the fields.  
For detailed field descriptions, see [Add Permission field descriptions](#) on page 239.
8. On the main menu bar, click **File > Save** to save the permissions.

### Add permission field descriptions

Name	Description
<b>Permission Management</b>	
<b>Name</b>	A user-defined name for a permission.
<b>Media Store entity ID</b>	The program ID, media store server instance, or media store server instance type to which you want to apply the permission.

*Table continues...*

Name	Description
	<p> <b>Note:</b></p> <p>You must enter a valid ID. An invalid ID does not save the permission. For example, you can find the valid ID of Media Store on the <b>Summary</b> tab of that Media Store.</p> <p>If you specify a media server instance or media server instance type, the system applies the permission to all programs that the media store queue uses. Because the permission is applicable for email and simple messaging work items, you must specify the Simple Messaging Media Store or EMS ID.</p>
<b>Permission rank</b>	<p>The order of importance given to a permission. You can give a rank to a permission when you want to assign multiple permissions to a contact.</p> <p>The lower number indicates the higher rank.</p>
<b>Interaction direction</b>	<p>A value that determines in what direction, the work items are moving when they receive special priority.</p>
<b>Permission type</b>	<p>A value that indicates whether the system allows or denies an agent to send or receive work items.</p> <p>If you assign the <code>public</code> access mode to a program and select <b>0 - Denied for Public Program</b> as the permission type, the system does not send the work item to an agent. This applies to a program that you specify in the <b>Media Store entity ID</b> field or a program that Media Store queue, which receives the work item, uses.</p> <p>If you assign the private program access mode to a program and select <b>1 - Allowed for Private Program</b>, the system sends the work item to an agent.</p>
<b>Minimum overall rating (%)</b>	<p>The percentage value that determines how closely the details of an incoming work item must match with a contact in the <b>ASContact</b> database to activate this permission.</p> <p>Values between 0-100 are valid.</p> <p>If you want an exact match to activate a permission, specify 100.</p> <p>If a lower level of identity surety is acceptable, use a lower value.</p>

*Table continues...*



Name	Description
	For example, if matching an email address at domain level is permissible, that is, the incoming contact is a member of a known company, specify 80.
<b>Notify denied contacts</b>	The check box to send an automatic notification to a contact informing them that their interaction is denied.
<b>Work Item Queue Management</b>	 <b>Note:</b> The system enables this section only when a contact can send work items.
<b>Queue priority</b>	A value that indicates the priority with which the system queues the work items from this contact to Media Director.
<b>Preferred agent ID</b>	The ID of a preferred agent to handle the work items from a contact.
<b>New destination ID</b>	The program ID of a program that you want the work items to use. If you want to use a program different from the program specified in a queue that receives the work item, enter a program ID.  If you specify a queue priority and preferred agent ID, you must specify the program ID.

## Closed Sender Group

When the program access mode is set to **Private**, the queue using that program receives emails only from contacts that are in the **ASContact** database and have the permission **Allowed for Private Program**. The contacts with this permission form the Allowed Sender Group. The sender gets an in-hours or out-of-office auto-response according to the schedule assigned to the program.

If an email comes from a contact that does not have permission for private program, or is unavailable in the database, the sender receives a rejected auto-response saying that “Closed Sender Group is set to true”, and “your email address was not found in the allowed list”, and the email message bans.

Instead of contacts, the administrator can add a domain for example, `activetelephony.co.nz`, and give permission for this domain.

In that case, emails coming from an email address, which belongs to that domain are permitted in that queue, and the sender receives an in-hours or out-of-office auto-response according to the schedule assigned to the program.

## Denied Sender Group

When a program access mode is set to **Public**, emails receiving from contacts that are not in the **ASContact** database or does not have any permission are queued by using the program. Moreover, the sender gets an in-hours or out-of-office auto-response according to the schedule assigned to the program.

A denied sender group can be created by giving the permission **Denied for Public Program** to individual contacts or domains.

The contacts with this permission form a Denied Sender Group. In addition, there is a field **Notify denied contacts**.

If, the **Notify denied contacts** check box is selected, the sender receives a Denied auto-response as "Your email address was found in the denied list".

If the **Notify denied contacts** check box not selected, the sender does not get auto-response. In both the cases, the email message is banned.

# Chapter 12: Communication Manager administration

Communication Manager Administrator (CM Admin) is a plug-in using which you can view and configure the Communication Manager components for Call Center Elite Multichannel.

To view and configure the settings, you must configure the Communication Manager connection by specifying the details of Communication Manager Server. After you configure the connection, you can view Communication Manager components, such as agents, VDNs, stations, and skills.

---

## Configuring Communication Manager connection

### About this task

Using this procedure, you can configure a Communication Manager connection.

### Procedure

1. In the left pane of Control Panel, click the **Configuration Manager** node and click **Edit connection configuration**.

The system displays the **Edit Connection Configuration** tab.

2. Enter the appropriate values in the fields.

---

## Edit Connection Configuration field descriptions

Name	Description
Description	The name of the Communication Manager connection. The system displays this name in the <b>Communicator Manager</b> node.
Host	The host name or IP address of the Communication Manager server.

*Table continues...*

Name	Description
<b>Username</b>	the user name to access the configured Communication Manager.
<b>Password</b>	The password of the specified user name.
<b>Password Confirmation</b>	The password of the specified user name.
<b>Pin and Pin Confirmation</b>	The pin number of the specified user name to gain access to Communication Manager.

---

## Communication Manager interface

The interface for configuring Communication Manager contains UI controls, such as tabs, panels, lists, and message lines. You can configure Communication Manager by specifying values in these controls.

Following are the UI controls available:

- **Tabs**

A separate tab is provided for each component that you can configure for Communication Manager. On each tab, you can either create new settings or modify the existing settings.

You can view the following tabs:

- Agents
- Stations
- Skills
- VDNs
- HolidayTables
- ServiceHoursTables
- Software Version

### List

On each tab, you can view that displays the objects corresponding to the tab that you select. For example, a list on the **Agents** tab displays all agents configured in Communication Manager. If you are connected to the Communication Manager server, the list displays the objects from the Communication Manager server. If you click an object in the list, the system displays the details of that object in the right pane.

### Buttons

Each tab has following buttons:

- **Clear**: Clears the text from the **Filter** text field and removes the filter applied to the list.

**Direction:** Changes the direction of the sorted list from ascending to descending and reverse. You can also select a value in the **Sort by** list to sort the list according to the selected option.

**New:** Creates a new object. The system displays the fields to specify settings.

**Refresh:** Refreshes the information on the selected tab. The objects are reloaded from the Communication Manager server.

**Save:** Saves the settings that you change. If an error occurs while saving the changes, the Message line displays the error details and the field that has an error. On successful saving, the system flashes the **Buttons** panel with green color.

**Discard.** Discards the settings that you have changed, but not saved.

### Collapsible panels

A panel in which the system displays the details of a selected object. You can view the collapsible panels in the right pane on the selected tab. When you select an object from an objects list, the system displays the details of the selected object in different collapsible panels, such as **General**, **Skills**, and **Advanced**. You can expand or collapse the panels by clicking the arrow on the panel head.

### Message line

A line above the collapsible panels that shows errors and messages. The system displays errors when it detects an invalid data in a field. The message line displays the error description for each invalid data field on a separate line. Moreover, the fields with invalid data are marked with red border around the field. If you click a message line, the system moves the cursor to a field that has an error.

---

## Agents field descriptions

Use this tab to add or change agent login IDs, skill assignments, and advanced settings.

Name	Description
List view	The list view shows the agents. The list can sort by Name or Login ID.
Context menu	You can clone, delete, or add an agent.
General	
LoginID	This field contains the identifier for the Logical Agent.
Name	Up to a 27 character string naming the agent. Any alphanumeric character is valid. Default is blank.
Password	This field appears only if both the AAS and AUDIX check boxes are cleared. Enter up to nine digits as the password that the agent must enter when an agent logs in to the system. Valid entries are the

*Table continues...*

Name	Description
	digits 0 through 9. Enter the minimum number of digits in this field specified by the Minimum Agent LoginID Password Length field on the Feature-Related System Parameters screen. The default is blank. Values entered in this field are not displayed on the screen.
<b>Confirmation</b>	This field appears only if both the AAS and AUDIX check boxes are cleared. Reenter the same password exactly as it was entered in the Password field. The default is blank. Values entered in this field does not display on the screen.
<b>Security Code</b>	The 4 digit security code (password) for the Demand Print messages feature. This field can be blank by default.
Skills  <b>Note:</b> If you add or change skills, the agent must log out and then log in again before the changes take effect.	
<b>Number (SN)</b>	Skill Number.
<b>Name</b>	Name of the skill.
<b>Level (SL)</b>	Skill Level. Enter a skill level for each skill that is assigned to the agent. 16 priority levels are available.
<b>Advanced</b>	
<b>VoiceMail</b>	You can choose None, AUDIX or AAS.
<b>Port Extension</b>	This field appears only if either the AAS or AUDIX check boxes are cleared. Enter the assigned extension for the AAS or AUDIX port. This extension cannot be a VDN or an Agent LoginID. The default is blank.
<b>Direct Agent Skill</b>	The number of the skill used to handle Direct Agent (DA) calls. Valid entries are 1 to 99, or blank by default.
<b>COR</b>	The Class of Restriction for the agent. Valid entries are 0 to 995. The default is 1.
<b>Auto Answer</b>	When using EAS, the auto answer setting for an agent applies to the station where the agent logs in. If the auto answer setting for that station is different,

*Table continues...*

Name	Description
	<p>the agent setting overrides the station setting. The following entries are valid:</p> <ul style="list-style-type: none"> <li>• all: immediately sends all ACD and non ACD calls to the agent. The station is also given a single ring while a non-ACD call is connected. The ringer-off button can be used to prevent the ring when, on the Feature-Related System Parameters screen, the <b>Allow Ringer-off with Auto-Answer</b> field is set to y.</li> <li>• acd: only ACD split or skill calls and direct agent calls go to auto answer. If this field is acd, non ACD calls terminated to the agent ring audibly.</li> <li>• none: all calls terminated to this agent receive an audible ringing treatment. This is the default.</li> <li>• station: auto answer for the agent is controlled by the <b>Auto-Answer</b> field on the Station screen.</li> </ul>
<b>Call Handling Preference</b>	<p>When calls are in queue and an agent becomes available, the skill-level setting delivers the highest priority, oldest call waiting for the highest level agent skill. Other choices are greatest-need and percent-allocation. Greatest-need delivers the oldest, highest priority call waiting for any agent skill. Percent allocation delivers a call from the skill that otherwise deviate most from the administered allocation. Percent-allocation is applicable only when you activate Business Advocate. For more information, see <i>Avaya Business Advocate User Guide</i>.</p>
<b>ACW Agent Considered Idle</b>	<p>Select y to have agents who are in After Call Work included in the Most-Idle Agent queue. This means that ACW is counted as idle time. Select n to exclude ACW agents from the queue. Valid entries are system by default, No, and Yes. The system value indicates that settings assigned on the Feature-Related System Parameters screen apply.</p>

## Adding a Skill

### About this task

To add a skill, perform the following steps:

### Procedure

1. Select a skill.
2. Drag and drop the selected skill to the **Assigned Skills** list box.

You can right-click the skill and select **Add** or double-click the skill to add the selected skill to the **Assigned Skills** list box.

3. Select a skill level.
4. Click **Save**.

## Deleting a Skill

### About this task

Perform the following steps to delete a skill:

### Procedure

1. Right-click a skill.
2. Click **Delete**.
3. Click **Save**.

## Stations field descriptions

Use the Station screen to administer individual phone sets or virtual phones. Use this tab to add or change stations.

Name	Description
<b>List view</b>	The list view shows the stations. The list can sort by Extension and Name.
<b>Context menu</b>	You can clone, delete, or add a new station.
<b>General</b>	
<b>Extension</b>	The extension for the station.
<b>Name</b>	A name for the person associated with this phone or data module. The system uses the Name field to create the integrated directory.
<b>Type</b>	For each station that you want to add to your system, you must specify type of phone in the Type field. You can distinguish between many different types of phones by this specification.
<b>Port</b>	<p>This field helps you to specify a port enter 7 characters, or an x. If this extension is registered as an IP endpoint, this field displays SXXXXXX, where XXXXXX is the number of previously registered IP stations. For example, if there are 312 IP sets already registered during your register, the extension can get port S000313.</p> <p>Valid entries</p> <ul style="list-style-type: none"> <li>• 01 to 64</li> </ul>

*Table continues...*



Name	Description
	<p>First and second numbers are the cabinet number</p> <ul style="list-style-type: none"> <li>• A to E</li> </ul> <p>Third character is the carrier</p> <ul style="list-style-type: none"> <li>• 01 to 20</li> </ul> <p>Fourth and fifth characters are the slot number</p> <ul style="list-style-type: none"> <li>• 01 to 32</li> </ul> <p>Sixth and seventh characters are the circuit number</p>
<b>Security Code</b>	The security code required by users for specific system features and functions, includes the following: Personal Station Access, Redirection of Calls Coverage Off-Net, Leave Word Calling, Extended Call Forwarding, Station Lock, Message Retrieval, Terminal Self-Administration, and Demand Printing. Minimum Security Code Length determines the required security code length.
<b>Display Language</b>	This field helps you to specify the language in which information is displayed on stations.
<b>Advanced</b>	
<b>TN</b>	The Tenant Partition number.
<b>COR</b>	The Class of Restriction (COR) number to select the desired restriction.
<b>COS</b>	The desired Class of Service (COS) number to select allowed features.
<b>Lock Messages</b>	This field helps you to restrict other users from reading or cancelling the voice messages or retrieving messages through Voice Message Retrieval.

## Skills field descriptions

The Skills corresponds to the Hunt Groups with appropriate settings.

Name	Description
<b>List view</b>	The list view shows the skills. The list can sort by Group_Number and Group_Name.
<b>Context menu</b>	You can clone, delete, or add a new skill.
<b>General</b>	
<b>Skill Number</b>	The skill number.
<b>Skill Name</b>	This field identifies the skill.

*Table continues...*

Name	Description
	Valid entries:27-character
<b>Skill Extension</b>	An unused extension number that must be assigned to the skill. The field cannot be blank.
<b>Skill Type</b>	<p>The following list shows how calls are handled for each skill type.</p> <ul style="list-style-type: none"> <li>• ucd-mia: When ucd-mia or ucd-loa is entered, a call routes to the idlest agent based on the time, when the agent finished the most recent call (ucd-mia).</li> <li>• ucd-loa: Least occupied agent based on agent occupancy (ucd-loa). Enter ucd-mia or ucd-loa if the hunt group has an AUDIX message. One of these entries is required while supporting the Outbound Call Management feature and when the <b>Controlling Adjunct</b> field isasai.</li> <li>• ead-mia: When ead-mia or ead-loa is entered, a call routes to the available agent with the highest skill level for the call.</li> <li>• ead-loa: Skill levels are available, Communication Manager routes the call to the idlest agent based on when the agent finished the most recent call (ead-mia), or the least occupied agent based on agent occupancy (ead-loa). With this action, a call is distributed to an agent best able to handle it if multiple agents are available.</li> <li>• pad: Enter pad (Percent Allocation Distribution) to select an agent from a group of available agents based on a comparison of the agent work time in the skill and the agent target allocation for the skill.</li> <li>• slm: Enter slm when you want to: <ul style="list-style-type: none"> <li>- Compare the current service level for each SLM administered skill to a user-defined call service level target and identify the skills that are urgent requirement of agent resources to meet the target service level.</li> <li>- Identify available agents and assess the overall opportunity cost of agents, and select only those agents whose other skills have the least requirement for the service at the current time.</li> </ul> </li> </ul>
<b>Advanced</b>	
<b>Queue</b>	A queue for the skill.

*Table continues...*

Name	Description
<b>LWC Reception</b>	<p>The destination for Leave Word Calling (LWC) messages left for the skill.</p> <p>Valid entries:</p> <ul style="list-style-type: none"> <li>• audix: If LWC is attempted, the messages are stored in AUDIX. The <b>Audix Name</b> field must also be filled in.</li> <li>• Msa: Messaging Server Adjunct</li> <li>• Spe: If LWC is attempted, the messages are stored in the system processing element (spe).</li> <li>• none</li> </ul>
<b>Message Center AUDIX Name</b>	The name of the Message Center AUDIX.
<b>Measured</b>	<p>This field provides measurement data for the ACD split or skill collected that is, internal to the switch for VuStats or BCMS. This measurement data is collected for VuStats and BCMS only if VuStats and BCMS are y on the System Parameters Customer Options (Optional Features) screen, and on the Hunt Group screen, the ACD field is y.</p> <p>Valid entries:</p> <ul style="list-style-type: none"> <li>• internal: If you enter internal in this field and if neither the VuStats or BCMS field is y on the System Parameters Customer-Options (Optional Features) screen, the system displays the following message:   <pre>&lt;value&gt; cannot be used, assign either BCMS or VuStats first</pre> <p>Contact your Avaya representative to assist with any changes you want to make on the System Parameters Customer Options (Optional Features) screen.</p> </li> <li>• external: Provides measurements created by the Call Management System that is, external to the server running Communication Manager.</li> <li>• both: Provides measurements collected both internally and externally.</li> <li>• none: Measurement reports for this skill are not required.</li> </ul>
<b>Stations Appears if, the ACD field is not selected. Two lists show the assigned stations and the unused stations. You can add or delete a station,</b>	

*Table continues...*

Name	Description
by selecting the station, clicking <b>Add or Delete</b> , and then saving the changes.	
<b>Advanced</b>	
<b>Coverage Path</b>	<p>A coverage path number. Coverage Path number assigns a coverage path for the hunt group and does not appear if the Vector field is (y).</p> <p>Valid entries:</p> <ul style="list-style-type: none"> <li>• 1– 999: Enter a coverage path number.</li> <li>• t1 – t999: Time of day table</li> <li>• blank</li> </ul>
<b>LWC Reception</b>	<p>This field defines the destination for Leave Word Calling (LWC) messages left for the hunt group.</p> <p>Valid entries</p> <ul style="list-style-type: none"> <li>• audix: If LWC is attempted, the messages are stored in AUDIX. The Audix® Name field must also be filled.</li> <li>• Msa: Messaging Server Adjunct.</li> <li>• Spe: If LWC is attempted, the messages are stored in the system processing element (spe).</li> <li>• none.</li> </ul>
<b>Message Center AUDIX Name</b>	The name of the Message Center AUDIX.
<b>Night Service destination</b>	<p>The destination where calls to this split redirects when the split is in the night service mode. All features do not work correctly if the destination is not a local extension. The features also do not appear if the Vector field is (y).</p> <p>Valid entries:</p> <ul style="list-style-type: none"> <li>• An assigned extension number can be a VDN extension. Enter the destination where calls to this split redirects when the split is in the night service mode.</li> <li>• Attd: An attendant group code.</li> <li>• blank</li> </ul>
<b>Measured</b>	This field provides measurement data for the ACD split or skill collected, which is internal to the switch, for VuStats or BCMS. This measurement data is collected for VuStats and BCMS only if VuStats and BCMS are y on the System Parameters Customer-

*Table continues...*

Name	Description
	<p>Options (Optional Features) screen, and the ACD field is y on the Hunt Group screen.</p> <p>Valid entries:</p> <ul style="list-style-type: none"> <li>• <b>internal:</b> If you enter internal in this field, and neither the VuStats or BCMS field is y on the System Parameters Customer-Options (Optional Features) screen, the system displays the following message:  <pre>&lt;value&gt; cannot be used; assign either BCMS or VuStats first</pre>           Contact your Avaya representative to assist with any changes you want to make on the System Parameters Customer-Options (Optional Features) screen.</li> <li>• <b>external:</b> Provides measurements done by the Call Management System that is, external to the server running Communication Manager.</li> <li>• <b>both:</b> Provides measurements collected both internally and externally.</li> <li>• <b>none:</b> Measurement reports for this skill are not required.</li> </ul>
<b>Timed ACW Interval (sec)</b>	<p>When a value is entered in this field, an agent in autoin work mode, who receives an ACD call from this hunt group is placed automatically into After Call Work (ACW) when the call drops. Enter the number of seconds the agent must remain in ACW following the call. When the administered time is over, the agent automatically becomes available. Timed ACW cannot be administered if the hunt group is adjunct controlled, is an AUDIX Message Center, or is an auto available split. The Timed ACW Interval field displays if, the ACD field is y.</p> <p> <b>Note:</b>            The settings on the VDN Timed ACW Interval field can override this field. Coordinate the settings for both fields in setting up delays.</p> <p>Valid entries:</p> <ul style="list-style-type: none"> <li>• 1-9999 or the number of seconds, the agent must remain in ACW following the blank call.</li> </ul>
<b>Redirect on No Answer (rings)</b>	This field displays if the ACD field is selected.

*Table continues...*

Name	Description
	<p>Valid entries:</p> <ul style="list-style-type: none"> <li>• 1-20: Enter the maximum number of rings before a call redirects back to the split or skill, or to the administered VDN.</li> <li>• blank: Deactivates Redirect on No Answer.</li> </ul>
<b>Redirect to VDN</b>	<p>This field displays if the ACD field is selected. To redirect a RONA call to a VDN instead of to the split/skill, enter the extension number of the VDN. The administered VDN must be on-premises and must be administered on the system. The VDN can specify a vector that in turns route to an off-premise VDN. You cannot enter an extension in this field if the Redirection on No Answer (rings) field is blank. Direct Agent calls go to the agent coverage path if the path is administered. Otherwise, the calls go to a VDN.</p> <p>Valid entries:</p> <ul style="list-style-type: none"> <li>• Assigned VDN or to redirect a RONA call to a VDN instead of to the split/skill, enter the blank extension number of the VDN.</li> </ul>
<b>Forced Entry of Stroke Counts or Call Work Codes</b>	<p>This field displays when the ACD field is selected.</p> <p>Valid entries:</p> <ul style="list-style-type: none"> <li>• Selected check box or cleared check box: Selecting check box means either a Stroke Count, or Call Work Code must be entered for each call answered by an agent when in the Manual-In mode.</li> </ul>
<b>Call Warning Threshold</b>	<p>This field displays if the Queue field is selected. Enter the number of calls that can be queued before the system flashes the queue status, which is feature buttons assigned on agents phones, and the optional Auxiliary Queue Call Warning Threshold lamp assigned to the split or skill. These lamps light steadily when at least one call is in queue and the threshold is not yet reached.</p> <p>Valid entries:</p> <ul style="list-style-type: none"> <li>• 1-999 and must be less than or equal to the assigned a port number.</li> </ul>
<b>Call Warning Port</b>	<p>This field displays if the Queue field is selected. Enter the seven character port number assigned to connect the optional external Auxiliary Queue Call Warning Threshold lamp that flashes when the number of calls in queue exceeds the queue warning</p>

*Table continues...*

Name	Description
	<p>threshold that is assigned in Calls Warning Threshold.</p> <p>This port is assigned to an Analog Line circuit pack or given an x designation if an extension is used. Enter the necessary characters.</p> <p>Valid entries:</p> <ul style="list-style-type: none"> <li>• 01-03 (DEFINITY CSI) or 1-64 (S87XX/S8300 Servers). First and second characters are the cabinet number</li> <li>• A to E: Third character is the carrier</li> <li>• 0 to 20: Fourth and fifth character are the slot number</li> <li>• 01-04 (Analog TIE trunks) 01-31: Six and seventh characters are the circuit numbers.</li> </ul> <p> <b>Note:</b></p> <p>For example, 01A0612 is in cabinet 01, carrier A, slot 06, and circuit number (port) 12.</p>
<b>Call Warning Extension</b>	<p>This field displays if the <b>Queue</b> field is selected and when the <b>Calls Warning Port</b> and the <b>Time Warning Port</b> fields are x. An extension is required when an X is placed in Calls Warning Port. This extension can be used by the Terminal Translation Initialization (TTI) feature to assign a port to this extension from the port. After Calls Warning Port is assigned a valid port either via TTI or the <b>change hunt-group</b> command, the extension is removed and considered unassigned.</p> <p>Valid entries:</p> <ul style="list-style-type: none"> <li>• Extension: Enter an unassigned extension. This field cannot be blank.</li> </ul>
<b>Time Warning Threshold</b>	<p>This field displays if the Queue field is selected and when the Calling Warning Port and the Time Warning Port fields are x. Enter the time in seconds so that a call can remain in the queue before the system flashes the Queue status lamps, which are feature buttons assigned members telephones and the Auxiliary Queue Time Warning lamp assigned to this split or skill.</p> <p>Valid entries:</p> <ul style="list-style-type: none"> <li>• 0-999 or blank: An entry of 0 provides a warning when a call is queued.</li> </ul>

*Table continues...*

Name	Description
<p><b>Time Warning Port</b></p>	<p>This field displays if the Queue field is selected. Enter the seven character port number assigned to the Auxiliary Queue Time Warning lamp that flashes when the time entered in Time Warning Threshold reaches by a call in queue.</p> <p><b>* Note:</b></p> <p>This port is assigned to an Analog Line circuit pack or given an X designation if an extension is used. Enter the necessary characters.</p> <p>Valid entries:</p> <ul style="list-style-type: none"> <li>• 01-03 (DEFINITY CSI) or 1-64 (S87XX/S8300 Servers): First and second characters are the cabinet number</li> <li>• A to E: Third character is the carrier 0 to 20 Fourth and fifth character are the slot number</li> <li>• 01-04 (Analog TIE trunks): Six and seventh characters are the circuit number 01-31</li> <li>• For example, 01A0612 is in cabinet 01, carrier A, slot 06, and circuit number (port) 12.</li> </ul>
<p><b>Time Warning Extension</b></p>	<p>This field displays if the Queue field is selected. An extension is required when an x is placed in Time Warning Port. This extension can be used by the Terminal Translation Initialization (TTI) feature to assign a port to this extension from the port. After Time Warning Port is assigned a valid port either via TTI, or the change hunt group command, the extension is removed and considered unassigned.</p> <p>Valid entries:</p> <ul style="list-style-type: none"> <li>• Extension: Enter an unassigned extension. This field cannot be blank.</li> </ul>

## VDNs field descriptions

This screen defines Vector Directory Numbers (VDN) for the Call Vectoring feature. A VDN is an extension number used to access a call vector. Each VDN is mapped to one call vector.

Name	Description
<p><b>List view</b></p>	<p>The list view shows the VDNs. The list can sort by Extension and Name.</p>
<p><b>Context menu</b></p>	<p>You can clone, delete, or add a VDN.</p>

*Table continues...*



Name	Description
<b>General</b>	
<b>Extension</b>	The extension number of the VDN. The extension is a number that starts with a valid first digit and length, as defined by the dial plan of the system.
<b>Name</b>	The name associated with the VDN.
<b>Vector</b>	This field specifies how to handle calls directed to the VDN. Select a vector.
<b>Skill1</b>	1–999 or None. Select the desired Skill numbers in each field or use None. The default is None.
<b>Skill2</b>	1 –999 or None. Select the desired Skill numbers in each field or use None. The default is None.
<b>Skill3</b>	1 – 999 or None. Select the desired Skill numbers in each field or use None. The default is None.
<b>Advanced</b>	
<b>TN</b>	This field specifies the Tenant Partition number for this VDN. When Meet-me Conferencing is n, an asterisk (*) displays next to the field name, indicating that this field follows VDN Override rules when the system changes the “active” VDN for a call.  Valid entries: <ul style="list-style-type: none"> <li>• 1 –100: For S87XX Series IP-PNC.</li> </ul>
<b>COR</b>	This field specifies the COR of the VDN. Valid entries Usage 0-995. Select a COR. This field cannot be blank.
<b>Attendant Vectoring</b>	This field indicates, if the vector you are defining is an attendant vectoring VDN.  Select to set the vector as an attendant vector. This entry dynamically changes the rest of the screen to eliminate field options available with other types of vectors.  Default is Not selected
<b>Meet me Conferencing</b>	This field displays only if, on the System Parameters Customer-Options (Optional Features) screen, the Enhanced Conferencing check box is selected. This field determines if the VDN is a Meet-me Conference VDN.   <b>Note:</b> If the VDN extension is part of your DID block, external users can access the conference VDN. If the VDN extension is not part of your DID block, only internal callers on your network

*Table continues...*

Name	Description
	<p>including DCS, QSIG, or remote access, callers can access the conference VDN.</p> <p>Select to enable Meet me Conference for this VDN. If <b>Meet-me Conference</b> is y, only <b>Extension, Name, Vector Number, Meet-me Conference, COR,</b> and <b>TN</b> fields display and the fields for page 2 change.</p> <p>Simultaneously, both <b>Attendant Vectoring,</b> and <b>Meet me Conference</b> cannot be set to y.</p> <p>If <b>Enhanced Conferencing</b> is y, but no other vectoring options are set to y, only Meet-me Conference vectors can be assigned.</p> <p><b>* Note:</b></p> <p>If the vector for Meet-Me conferencing allows a new party to join a conference immediately, and that party is joining as an H.323 IP trunk user, the caller might not have talk path with the others in the conference. To prevent this, include, in the vector, a short delay before a new party joins the Meet-Me conference, such as a step to collect digits, a 1-second delay, or to play an announcement. As Meet-Me vectors are always configured with announcements and digit collections, this should not be an issue.</p>
<p><b>Allow VDN Override</b></p>	<p>This field appears if Meet-me Conferencing is n. The Allow VDN Override field allows the system to change the “active” VDN for a call. The “active” VDN is the VDN to be used for parameters associated with the call such as VDN name, skills, tenant number, BSR application, and VDN variables.</p> <p><b>* Note:</b></p> <p>The “active” VDN can be specified in some vector commands as a keyword. When a vector step with the keyword “active” executes, the extension for the call “active” VDN as defined by VDN override rules substitutes for the keyword while processing the vector command. The keyword “active” can be used as the VDN extension for the go to command “counted-calls” conditional, the go to command “rolling-asa for VDN” conditional, the messaging command mailbox extension, or can be defined as the “vdn” vector variable type assignment. The keyword “latest,” , which is the last VDN</p>

*Table continues...*

Name	Description
	<p>routed to, can also be assigned in these same vector commands or variables, but the “latest” VDN is not changed by VDN Override settings.</p> <p>If selected, this field permits a routed to VDN that is, by a route to number or route to digits vector command, to become the “active” VDN. The first VDN reached by the call becomes the “active” VDN.</p> <p>If not selected, the routed-to VDN does not become the active VDN. The parameters of the original VDN are used. This action occurs by default.</p>
<b>Measured</b>	<p>This field displays if <b>Meet me Conferencing</b> is not selected. Used to collect measurement data for this VDN. Data can be collected for reporting by BCMS or CMS.</p> <p> <b>Note:</b></p> <p>On the System Parameters Customer-Options (Optional Features) screen, <b>BCMS</b> must be y for the <b>Measured</b> field to be set to internal or both. In addition, the appropriate CMS release must be administered on the Feature-Related System Parameters screen if this field is changes to external or both.</p> <p>Valid entries:</p> <ul style="list-style-type: none"> <li>• Internal: Data is measured internally by BCMS.</li> <li>• External: Data is measured internally by CMS.</li> <li>• Both: Data is measured internally by both BCMS and CMS.</li> <li>• None: Data is not measured. This is default.</li> </ul>

## Holiday Tables field descriptions

Use this screen to define individual holidays or holiday ranges.

Name	Description
<b>List view</b>	The list view shows the holiday tables. The list can sort by Number or Name.
<b>Context menu</b>	You can clear, copy, or paste a holiday table.
<b>General</b>	

*Table continues...*

Name	Description
<b>Number</b>	Display-only field identifying the holiday table number.
<b>Name</b>	Display-only field identifying the name of the table.
<b>Time Frames</b>	
<b>Start Month</b>	The starting month of the holiday. Valid entries 1 to 12.
<b>Start Day</b>	The starting day of the holiday. Valid entries 1 to 31
<b>Start Hour</b>	The starting hour of the holiday using a 24-hour clock. Valid entries 0 to 23
<b>Start Minute</b>	The starting minute of the holiday. Valid entries 0 to 59
<b>End Month</b>	The ending month of the holiday. Valid entries 1 to 12.
<b>End Day</b>	The ending day of the holiday. Valid entries 1 to 31.
<b>End Hour</b>	The ending hour of the holiday using a 24-hour clock. Valid entries 0 to 23.
<b>End Minute</b>	The ending minute of the holiday. Valid entries 0 to 59.
<b>Description</b>	A phrase to describe the holiday.

---

## Service Hours Tables field descriptions

Use this screen to set service hours.

Name	Description
<b>List view</b>	The list view shows the service hours tables. The list can sort by Number or Description.
<b>Context menu</b>	You can clear, copy, or paste a service hours table.
<b>General</b>	
<b>Number</b>	The table number that you entered on the command line.

*Table continues...*

Name	Description
<b>Description</b>	A description for the table. You can enter a 1 to 27 character alphanumeric table name. The default is blank.  Example: Call-ahead Reservations
<b>Use time adjustment for time location</b>	This field indicates to a field on the Locations screen for time zone offset and daylight-saving rule time adjustments. <ul style="list-style-type: none"> <li>The Multiple Locations feature must be enabled to administer more than one location (2-250).</li> <li>You can assign a location to a gateway or to a network region.</li> <li>Administer the location where the incoming trunk terminates.</li> </ul>
<b>Time Frames</b>	
<b>Start/End</b>	This field defines the range of office hours for each day of the week. Always ensure that the start time is earlier than the end time.  hour: 0-23 minute: 0-59  The hour range must be within the specified day, from midnight (00:00) until 23:59.  If a time range goes past midnight for example, Friday 19:00 to Saturday 02:00, enter the time in two ranges. Set up the first range as Friday from 19:00 to 23:59 and the second range as Saturday from 00:00 to 01:59.  A time is considered to be in the table from the first second of the start time for example, 08:00:00. Besides, it is still considered to be in the table until the last second of the end time for example, 17:00:59.

---

## Software version field descriptions

Name	Description
<b>Version</b>	The current version of the software.
<b>Version On Disk</b>	The current version of the software on disk.
<b>Translation Date</b>	The translation date.
<b>Translation Date On Disk</b>	The translation date on disk.

*Table continues...*

Name	Description
<b>Disk Second Copy</b>	The state of the second copy on disk.
<b>Refresh</b>	This button refreshes the software version details.
<b>Save Translation</b>	This button sends a command to Communication Manager to save the configured data to the disk.

# Chapter 13: Configuration Server

---

## Configuration Server overview

Configuration Server acts as a central repository to store configuration information of Avaya Aura® Call Center Elite Multichannel desktop applications. Using Configuration Server, a contact center or network administrator can change the configuration information of an application without going to individual desktops.

**!** **Important:**

Configuration Server is only accessible to the first default administrator. Therefore, a newly created user with administrative privileges cannot access Configuration Server.

A back end database such as SQL Server or SQL Server Express stores the information that Configuration Server processes. Configuration Server operates as a service and does not have a user interface. Therefore, a separate application called Configuration Manager is used to add configuration data to the database.

Configuration Server Manager configures the server and is also capable to start and stop the server.

The Configuration Client control integrates a Call Center Elite Multichannel application with the configuration information. With a configuration client, an application can transparently access information, regardless of the location. When a Call Center Elite Multichannel application is installed, this control is stored on the computer of the client.

Configuration Server reads appropriate configuration information from the system registry of Configuration Server Manager and opens the database that uses the information. After opening the database, Configuration Server sets up a listening socket on the specified port and waits for incoming client connections.

When a configuration client connects to Configuration Server, the Configuration Server passes an application name and a configuration filter having properties such as computer name and logged in user name. To identify the required configuration, the server executes an appropriate stored procedure against the database that uses the name of the application and filter.

The stored procedure returns configuration data that matches the configuration filter for that application. The server packages up the information and sends the information to the configuration client. To make the processing easy, the format of the data is exactly the same as that in a local .ini file.

When the user closes the application, the configuration client sends new or modified data back to the server for updating the database.

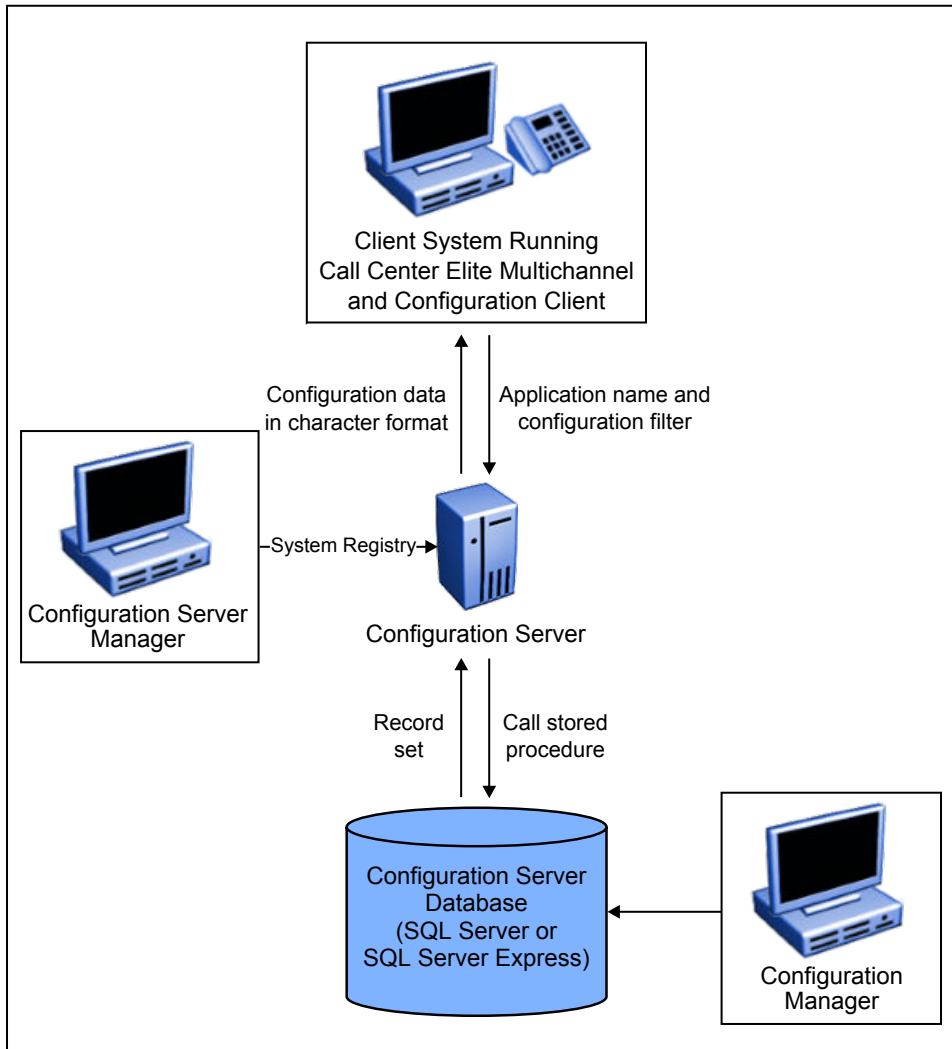

## Language Support

The Configuration Server, Configuration Server Manager, and Configuration Manager are available in English only.

However, presently the Configuration Manager supports entering and reading of data in any of the languages supported by Call Center Elite Multichannel applications. This is achieved by using the AELanguage controls.

The database must be installed using the same character set (code page) for your chosen language.



Language	code
English	1252
French	1252
German	1252
Italian	1252
Portuguese (Brazilian)	1252
Spanish (Castilian)	1252
Spanish (Colombian)	1252
Chinese (Simplified)	936
Chinese (Traditional)	950
Japanese	932
Russian	1251
Korean	949

---

## Configuration Server installation

For instructions on how to install Configuration Server, see *Installing Avaya Aura® Call Center Elite Multichannel*.

In addition to the standard installation steps, this document explains:

- How you can use command line parameters during installation to dictate where configuration information is retrieved.
- How you can change the configuration source from the local .inc file to the Configuration Server if an application is already installed.
- How to automatically install an application following a set of predefined selection options.

---

## Creating or upgrading Configuration Server (ACS) Database

### About this task

Using this procedure, you can create or upgrade ACS Database.

### Before you begin

You must install Microsoft SQL Server on a dedicated server. For information about installing SQL Server, see *Installing Call Center Elite Multichannel*.

**\* Note:**

Microsoft SQL Server must have the mixed mode authentication and not the Windows only authentication. The mixed mode authentication specifies that you have configured SQL Server for Windows and SQL Server.

**Procedure**

1. From the Call Center Elite Multichannel installation DVD, copy the SQL Script folder from the <Call Center Elite Multichannel installer>\Avaya Aura CC Elite Multichannel\Server\Configuration Server directory to the server where Microsoft SQL Server is installed.
2. From the Call Center Elite Multichannel installation DVD, copy the AS Maintain Database folder from the <Call Center Elite Multichannel installer>\Utilities directory to the server where Microsoft SQL Server is installed.
3. From the SQL Script folder that you have copied, open the Run AS Maintain Database.bat file in a text editor, such as Notepad.
4. In the Run AS Maintain Database.bat file, find the ..\Utilities\AS Maintain Database string and replace the string with the path where you have copied the AS Maintain Database folder.

For example, if you have copied the AS Maintain Database folder to the C:\CS\_Server folder, replace the \Utilities\AS Maintain Database string with C:\CS\_Server\AS Maintain Database.

5. Perform one of the following steps:
  - To create the database with default instance, verify that the **ASServerName** parameter is empty.
  - To create the database with named instance, enter the server instance name for the **ASServerName** parameter.
6. Save and close the Run AS Maintain Database.bat file.
7. Right-click the Run AS Maintain Database.bat file and click **Run**.

After the batch file finishes running, a log file is created in the same folder to confirm the successful creation of ACS Database.

---

## Backup / Restore / Delete databases

If you are using SQL Server the simplest way to backup, restore, and delete Call Center Elite Multichannel databases is via Microsoft GUI management tool that is, SQL Server Management Studio Express.

SQL Server Management Studio Express is automatically installed with the full version of SQL Server. However, you can download SQL Server Management Studio Express from Microsoft's website.

<http://search.microsoft.com/en-us/DownloadResults.aspx?q=Management+Studio+Express>

---

## Starting Configuration Server

### Procedure

1. From the Windows Start menu, click **All Programs > Avaya Aura CC Elite Multichannel > Server > Configuration Server > Configuration Server Manager**.

The system displays the Configuration Server Manager dialog box.

2. In the **Client Connections** section, check the default values in the **IP Address** and **IP Port** fields.
3. Select the **Automatically Start Service on Server Boot** check box.
4. In the **SQL Server Name** field, enter the name of the server running the Configuration Server database.
5. In the **Login Name** field, enter the user name to gain access to the database.

The user name is automatically named ACS when you run the database script.

6. In the **Password** field, enter the password associated with the user name.

By default the password is **CCEUser0**.

7. Click **Browse** to select the location for storing the error logs.
8. Click **Apply** to save the settings.
9. In the **Server State** area, click **Start** to start the service.

---

## Configuration Manager overview

Configuration Manager is the user interface by which an administrator can add application configuration data to the Configuration Server database.

By default, Configuration Manager displays the configuration templates for all Call Center Elite Multichannel desktop applications. These templates are automatically added to the Configuration Server database when the database is created.

### **Note:**

The first time you start and close the Configuration manager, the system displays the **Microsoft Management Console** (MMC) dialog box. Click **Yes** to save the file in the 3.0 version format.

After you save the file, the system does not display the **MMC** dialog box the next time you close Configuration Manager.

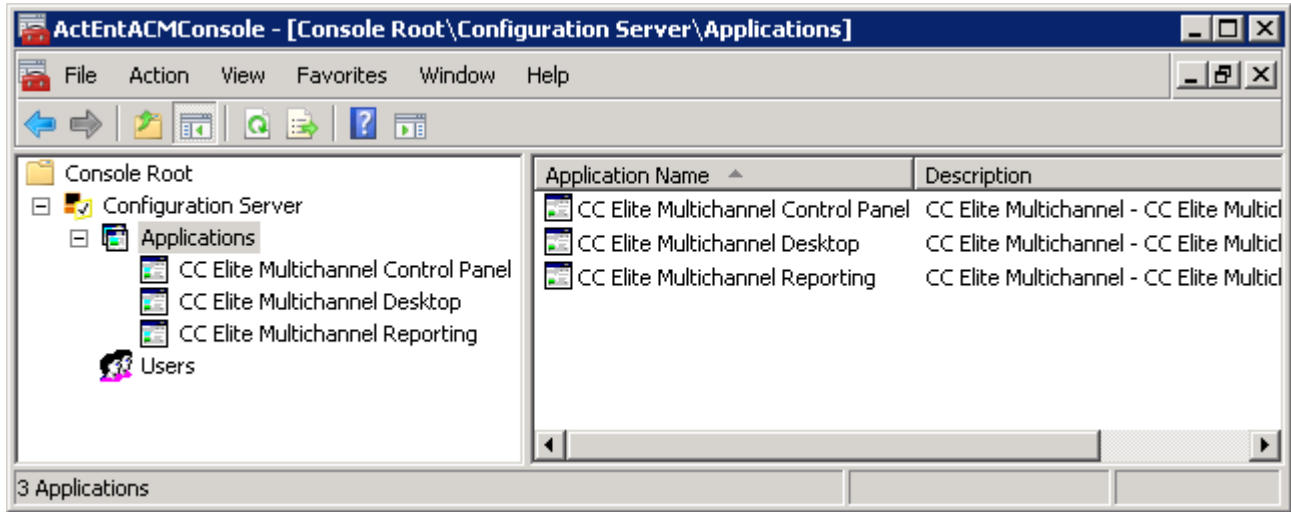

**\* Note:**

Configuration Manager runs with Microsoft Windows XP Professional 32-bit, SP2, 2000 Professional, and Microsoft Management Console (MMC) 1.2, or later and Microsoft Internet Explorer 6.0 SP1 or later. MMC 1.2 releases with Windows 2000. If you do not have MMC, download it from the Microsoft website.

## Logging to the database

### About this task

To start the Configuration Manager:

### Procedure

1. From the Windows Start menu, click **All Programs > Avaya Aura CC Elite Multichannel > Server > Configuration Server > Configuration Manager**.

The system displays the Configuration Manager dialog box.

In the left pane, you can view the hierarchical tree structure with three nodes: Configuration Server, Applications, and Users.

2. In the left pane, right-click the **Configuration Server** node and select **Database > Select Database**.

The system displays the Select Database dialog box.

3. In the **Database Server Name** field, enter the name of the server running the Configuration Server database.

- In the **User Login Name** field, enter the user name to gain access to the database.

The user name is automatically named ACS when you run the database script.

- In the **Password** field, enter the password associated with the user name.

By default the password is **CCEUser0**.

- Click **OK**.

**\* Note:**

By default, Configuration Manager shows the application templates that were automatically added to the Configuration Server database when the database is created.

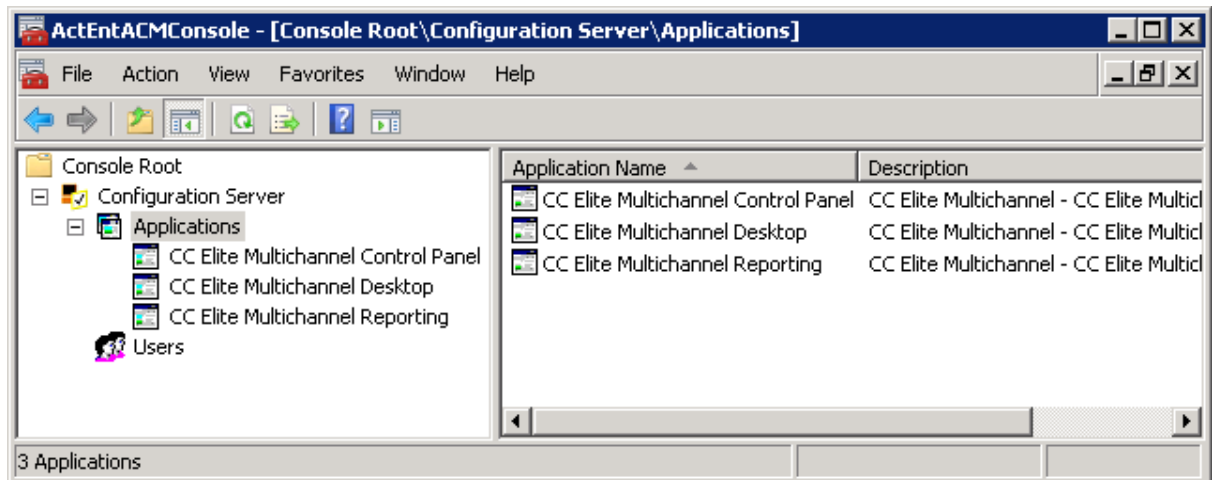

**\* Note:**

The first time you start and close the Configuration manager, the system displays the Microsoft Management Console (MMC) dialog box. Click **Yes** to save the file in the 3.0 version format. After you save the file, the system does not display the MMC dialog box the next time you close Configuration Manager.

## Editing the Default Application template

### About this task

To edit the default application template:

### Procedure

- In the Configuration Manager window, right-click the application name and select **Properties**.

The system displays the Application Properties screen.

The template contains four columns of prewritten application data, for column descriptions see [Default Application template column descriptions](#) on page 270.

2. In the Value column, edit and add data to ensure that the template contains the configuration information that is common to all users.

By default, Call Center Elite Multichannel applications encrypt data for parameters containing the word Password. For more information, see *Installing Avaya Aura® Call Center Elite Multichannel*.

**\* Note:**

Three types of editable cells are text boxes, drop-down list boxes, and buttons that display dialog boxes for more complex data entry.

3. Click **Add** to add a new row of configuration data.

**\* Note:**

This method only creates blank cells in the Value column.

4. In the added row, enter the appropriate configuration data.
5. Click **OK** to save your application template changes.

## Default Application template column descriptions

Name	Description
<b>Section</b>	Sets of related configuration data. Read-only
<b>Key</b>	Properties belonging to the application. Read-only
<b>Value</b>	Values related to the application keys. Some values which you can edit, display automatically by default. While others are blank and ready for your selection.
<b>Description</b>	Descriptions of the application keys. Read-only

## Creating New Application template

### About this task

If you have developed your CTI application by using Developer and the Configuration Client, you can choose for the application to source the configuration data from the Configuration Server. In this case, you must create a new template that contains configuration properties specific to your application. The template acts as a basis for user configurations.

To add a new application to the database directly from Configuration Manager:

**Procedure**

1. In Configuration Manager window, right-click the **Applications** node and select **New Application**.

The system displays the New Application dialog box.

2. In the **Application Name** field, enter the name of the new application.

**\* Note:**

The application name is limited to 50 characters.

3. In the **Description** field, enter the description for the new application.

4. Click **OK**.

The system adds the new application in **Applications** node of Configuration Manager.

5. In the Configuration Manager window, right-click the new application node and select **Properties**.

The system displays the Application Properties dialog box.

6. Click **Add** to add a new row of configuration data.

In the new row enter the appropriate values in the columns.

Section	Key	Value	Description
MyPhone	MyDN		The extension number monitored by t
	VoicemailDN	8888	The voicemail extension number
TServices	ServerName	AVAYA#AVAYA_ECS#CS1	The T-link string, eg. Avaya#3_S
	UserName		The user name used for logging in
	Password		The user password used for logging i
	ServerNameSec	AVAYA#G3_SWITCH#CS1	The backup T-link string
	UserNameSec		The user name used for logging in
	PasswordSec		The user password used for logging i

For the new row column descriptions, see [Add row for new application template field descriptions](#) on page 272.

7. To add another row click **Add**.

**\* Note:**

You must type a Section name, even if the Section name is same as the section name in the previous row. When you move to another cell, the text combines to form one overall section name for those keys.

8. Click **OK** to save and close your application template.

**\* Note:**

After you save the data, the data in the **Section** column becomes read-only.

---

## Add row for new application template field descriptions

Name	Description
<b>Section</b>	A section is a set of related configuration data.  If, for example, you are planning to add several keys related to the user phone, you can create a section named "MyPhone".
<b>Key</b>	A key is a property belonging to the application.  If, for example, you are planning to add the user phone extension, you can create a key named as "MyDN".
<b>Value</b>	The value that relates to the application key.  If the value is common to all users, enter that value in the <b>Value</b> column. If the value is not common to all users, leave the Value column blank.
<b>Description</b>	An important information for an administrator who must add and change the configuration data.

---

## Configuration filter properties

When a Configuration Client connects to the Configuration Server, the Configuration Client passes an application name and configuration filter to the Configuration Server. Using the application name and filter to identify the required configuration, the server executes an appropriate stored procedure against the database.

A configuration filter is made of one or more name/value pairs. Because Machine Name and User Network Login Name are likely to be the most commonly used name or value pairs, machine Name and User Network Login Name are set up by default in Configuration Manager. You cannot delete these pairs, but you can add others to the database.

---

## Adding configuration filter properties

### About this task

To add a new name or value pair:

### Procedure

1. In the Configuration Manager window, right-click the **Users** node and click **Filters**.

The system displays the Edit Filters dialog box.



2. Click **Add** to add a blank line.
3. Double-click the cell in the **Short Name** column, and enter the short name.

**\* Note:**

The short name is used in the client application start up command line. It can be a single character, single word, or two or more words with no spaces between the words.

4. Enter 1 in the **Default Value** column if you want the client application start up command line to specify a default value.

Leave the cell in the **Default Value** column blank if you want the client application start up command line to specify a user specific value.

5. In the **Description** column, enter the short description for the name and value pair.
6. Click **OK** to save the name and value pair.

**\* Note:**

New name or value pairs can be deleted at any time by selecting the line and clicking the **Delete** button.

---

## Adding user to a database

### About this task

To add a user to the database and assign filter values that relate to that user:

### Procedure

1. In the Configuration Manager window, right-click the **Users** node and select **New User**.  
The system displays the New User dialog box.
2. In the **User Details** section, enter the appropriate values in the **User Name** and **Description** fields.
3. In the **Filter Details** area, enter the unique, user-specific filter values in the text fields.

**\* Note:**

One or more of these values with the related short name must be specified in the client application start-up command line. With these values, the Configuration Server can identify the user unique set of configuration data.

4. Click **Save and Add Next User** button to add another user to the application database.
5. Click **OK**.

You can view the new user in the **Users** node in the Configuration Manager window.

---

## Assigning a user to an application

### About this task

Use this procedure to assign a single user to an application.

### Procedure

1. In the Configuration Manager window, click the **Users** node.  
The system displays the users from the database in the right pane.
2. In the right pane, select a single user or multiple users, and drag and drop the selected users over the name of the application in the **Applications** node.

The user configuration immediately takes on the attributes of the application template.

#### **Note:**

To view the attributes, right-click the user name under the application node and select Properties from the pop-up menu. You can then complete or customize the user configuration.

### Related Links

[Completing a user configuration](#) on page 274

---

## Completing a user configuration

### About this task

When you assign a user to an application, the assignment automatically takes the default attributes of the application template.

To customize or complete a user configuration, perform the following procedure.

### Procedure

1. In the Configuration Manager window, right-click the user name in the **Application** node and select **Properties**.

The system displays the Edit Configuration dialog box with information about Section, Configuration Key, and Configuration Value. The values in the Section and Configuration Key columns are read-only.

Section	Key	Value	Description
General	Language		The language it uses
	Server Instance ID		The server instance ID of this application
	Minimize to System Tray	False	Whether the applicaiton creates an icon in system tray when it is
	Window Title	Contact Center Express	The title of the main window
	Window Icon		The file name of the icon which will be used by the main window
	Product ID	6	
Error Logging	Enable Options Menu	True	Whether the options menu is enabled in the applicaiton.
	Enable Slide ToolWindow	True	
	Error Log Level	4	NONE=0; INFORMATION=1; MINOR=2; MAJOR=4; FATAL=8
	Error Log File Path	ErrorLog	The path of the error log
	Error Log File Extension	ASGUIHost.Log	The text that the error log file name ends with
	Maximum Error Log File Sized KB	10000	The error log file size in KB
	Error Log Mode	1	The error logging mode. 1 -File only, 2 - TTrace only, 3 - Both
	Error Log TTrace Host		The TTrace server host name
	Error Log TTrace Port	10400	The TTrace server port number
License Director	Error Log Use Old Log Format	False	Set to True if error logging should happen in old (not common logging
	Primary License Director IP		
	Primary License Director Port	29095	
	Secondary License Director IP		
	Secondary License Director Port	29095	
Window Layout	Connect License Director	False	Whether the applicaiton will connects to the license director. Set its
	Enable Debug Trace	False	
	Left Position		
	Top Position		
	Window Width		
	Window Height		
Plug In Assembly List	Maximized	False	
	Layout File Folder		
	Media Controller Section	Media Controller	Specifies the section name of the Media Controller plugin

- In the **Value** column, enter the appropriate user-specific data in the blank cells.

**\* Note:**

By default, Call Center Elite Multichannel application encrypts data for parameters containing the word Password. For more information about configuration commands, see *Installing Avaya Aura® Call Center Elite Multichannel*.

- (Optional) Edit the default values in the **Configuration Value** cells.
- Click **Add** to add a new row of configuration data and enter the appropriate data.
- Click **OK** to save your user configuration.

## Assign multiple users to an application

### Procedure

- In the left pane of the Configuration Manager window, right-click the application name and select **New > New Configuration**.

The system displays the Add Configuration dialog box.

2. In the **Selected** column, select the check box corresponding to the user that you want to assign to the application.
3. Click **OK**.

 **Note:**

You can assign all users from the database to an application.

---

## Completing a user configuration

### About this task

When you assign a user to an application, the assignment automatically takes the default attributes of the application template.

To customize or complete a user configuration, perform the following procedure.

### Procedure

1. In the Configuration Manager window, right-click the user name in the **Application** node and select **Properties**.

The system displays the Edit Configuration dialog box with information about Section, Configuration Key, and Configuration Value. The values in the Section and Configuration Key columns are read-only.

Section	Key	Value	Description
General	Language		The language it uses
	Server Instance ID		The server instance ID of this application
	Minimize to System Tray	False	Whether the application creates an icon in system tray when it is
	Window Title	Contact Center Express	The title of the main window
	Window Icon		The file name of the icon which will be used by the main window
	Product ID	6	
Error Logging	Enable Options Menu	True	Whether the options menu is enabled in the application.
	Enable Slide ToolWindow	True	
	Error Log Level	4	NONE=0; INFORMATION=1; MINOR=2; MAJOR=4; FATAL=8
	Error Log File Path	ErrorLog	The path of the error log
	Error Log File Extension	ASGUIHost.Log	The text that the error log file name ends with
	Maximum Error Log File Size KB	10000	The error log file size in KB
	Error Log Mode	1	The error logging mode. 1 - File only, 2 - TTrace only, 3 - Both
	Error Log TTrace Host		The TTrace server host name
License Director	Error Log TTrace Port	10400	The TTrace server port number
	Error Log Use Old Log Format	False	Set to True if error logging should happen in old (not common logging)
	Primary License Director IP		
	Primary License Director Port	29095	
	Secondary License Director IP		
Window Layout	Secondary License Director Port	29095	
	Connect License Director	False	Whether the application will connect to the license director. Set its
	Enable Debug Trace	False	
	Left Position		
Plug In Assembly List	Top Position		
	Window Width		
	Window Height		
	Maximized	False	
Layout File Folder	Layout File Folder		
	Media Controller Section	Media Controller	Specifies the section name of the Media Controller plugin

2. In the **Value** column, enter the appropriate user-specific data in the blank cells.

**\* Note:**

By default, Call Center Elite Multichannel application encrypts data for parameters containing the word Password. For more information about configuration commands, see *Installing Avaya Aura® Call Center Elite Multichannel*.

3. (Optional) Edit the default values in the **Configuration Value** cells.

4. Click **Add** to add a new row of configuration data and enter the appropriate data.

5. Click **OK** to save your user configuration.

## Live scenario

An insurance company is running Call Center Elite Multichannel Desktop to manage the flow of all calls and multimedia work items. The call center of the insurance company employs 140 agents, and these agents are divided into six groups based on the knowledge area. The company wants to use Configuration Server to quickly set up Call Center Elite Multichannel Desktop configurations for all six groups of agents.

To quickly set up Call Center Elite Multichannel Desktop configurations for all six groups of agents, one quick solution is to create six different templates. The six templates are created in a way that one template is for each group and assign agents to those groups.

To create different templates for different groups see [Creating different templates for different groups](#) on page 278.

---

## Creating different templates for different groups

### About this task

Use this procedure to create six different templates for six different groups and assign agents to those groups.

### Procedure

1. Open Configuration Manager and log in to the Configuration Server database.  
The CC Elite Multichannel Desktop loads as an application by default.
2. To create different templates for different groups, import the CC Elite Multichannel Desktop template (AS Contact Center Express Desktop Template Add.sql) separately for each group and rename appropriately.

```
Import templates from C:\Program Files (x86)\Avaya \Avaya Aura CC Elite  
Multichannel\Server\Configuration Server\SQL Script
```

3. Edit each application template so that the template contains the default attributes to suit a particular group of agents.
4. Add all agents to the database.
5. Drag and drop each agent into one of the CC Elite Multichannel Desktop groups created.
6. Customize each configuration by adding agent-specific configuration information, if required.

---

## Deleting a user configuration

### Procedure

1. To delete a user configuration perform one of the following steps:
  - Click the user name under the **Application** node and press **Delete** key.
  - Right-click the user name under the **Application** node and select **Delete**.
2. Click **OK** in the Delete this configuration message dialog box.

---

## Deleting a user from the database

### Procedure

1. To delete a user from the database, perform one of the following steps:
  - Click the user name under the **User** node and press the **Delete** key.
  - Right-click the user name under the **User** node and select **Delete**.
2. Click **OK** in the Delete this user message dialog box.

 **Note:**

If the user has a user configuration assigned to an application, a message displays informing you the deletion is not successful. Delete the user from the application and repeat the given steps.

---

## Deleting an application template

### Procedure

1. To delete an application with all user configurations, perform one of the following steps:
  - Click the application name and press the **Delete** key.
  - Right-click the application name and select **Delete**.
2. Click **OK** on the Do you want to delete this application message dialog box.

---

## Updating templates

### About this task

To perform the given steps, you must consider the following conditions to update templates:

- If you have upgraded a Call Center Elite Multichannel application, using a recently released service pack.
- If your old application has sourced the configuration data from the Configuration Server.

### Procedure

1. Run the service pack or version upgrade installer first, to get the new AS Script Master file and new scripts.
2. Run the `Run AS Maintain Database.bat` file to update the application templates.

## Command Line parameters

Configuration Client accepts command line parameters that dictate where it retrieves configuration information for the desktop applications of Agent, Wallboard, and Call Center Elite Multichannel Desktop. The three possible configuration data sources are the:

- Configuration Server
- Local configuration file
- System registry

The application passes the information taken from the command line directly into the control. If a parameter exists in the command line, the value of the parameter overrides information set within the container application. If a command line contains multiple entries for the same parameter, only the first instance is used.

## Command Line parameter descriptions

Command Line Parameter	Description
Application Name /z	The Application Name parameter is the name of the application that is configured in Configuration Server. Configuration Client requests configuration information from Application Name.
Primary Server Name /s	<p>The Primary Server Name parameter is the name of the primary Configuration Server that Configuration Client connects for configuration information. This value can be the name of the server, or the IP address of the server.</p> <p>Alternatively, if you want to retrieve configuration information from the system registry, you can set the Server Name to:</p> <ul style="list-style-type: none"> <li>• HKEY_LOCAL_MACHINE: Configuration Client retrieves information from the local machine system registry.</li> <li>• HKEY_CURRENT_USER: Configuration Client retrieves information from the local user system registry.</li> </ul>
Primary Server Port /p	The Primary Server Port parameter is the primary TCP/IP port used for communication between the Configuration Server and the Configuration Client. When absent from the command line, the prescribed default, 29091, is used. The Server Port parameter enables you to override the default port.
Secondary Server Name /s2	The Secondary Server Name parameter is the name of the backup Configuration Server that Configuration Client connects to for configuration information. This value can be the name of the server or the IP address of the server.
Secondary Server Port /p2	The Secondary Server Port parameter is the backup TCP/IP port used for communication between the Configuration Server and the Configuration Client.

*Table continues...*



Command Line Parameter	Description
Configuration Filter /a	<p>The Configuration Filter parameter is a compulsory parameter if you want to source configuration information from the Configuration Server.</p> <p>A configuration filter is a name, or value pair, or a combination of name or value pairs by which a user and the application configuration profile is identified and retrieved from the Configuration Server database.</p> <p>A configuration filter is defined in the command line using a name=value format. Pairs are separated by semicolons. For example, Name1=Value1;Name2=Value2.</p> <p>Your command line can contain M=%M or U=%U, which are optional filters built in to Configuration Server. When Configuration Client recognizes this text, it replaces %M with the name of the machine running the application and %U with the user network login name. If the user is in the database, these base filters are sufficient to locate the data of user.</p> <p>M (Machine Name) and U (User Network Login Name) are not compulsory filters. In fact any other filter can be designed and added to a database to locate the user. For example a filter named Pswd can be set up with the user password as the value.</p> <p>The Configuration Filter parameter is not required when dealing with the system registry or local configuration file.</p>
File Name /f	<p>The File Name parameter is the name of the local file that contains configuration information. If a full file path is specified, Configuration Client points directly to the file. If only the file name is specified, Configuration Client looks for the file in the default directory in which the application is running.</p> <p>The File Name and Server Name command line parameters are not mutually exclusive. If both are available in the command line, the Server Name takes precedence. If the server cannot be contacted, Configuration Client attempts to extract information from the specified configuration file.</p>
Logging State /t	<p>Error logging for Configuration Client can be enabled by setting the Logging State parameter to true (/t True). Logged errors are sent to a file in the application directory under the name "ConfigErrorLog.txt". When the Logging State parameter is absent from the command line, error logging is disabled.</p>
Password Encryption /pwd	<p>The automatic encryption on data associated with configuration parameter names that contain the case insensitive strings Password or Pswd can be turned off by setting the Password Encryption parameter to false (/pwd false). In this case, configuration data must be explicitly encrypted by the user</p>

*Table continues...*

Command Line Parameter	Description
	inserting %%ENCRYPT commands. The /pwd parameter must be in lowercase.
Command Processing /d	With this command line parameter, you can disable command processing. By default, command processing is enabled. For more information about command processing, see <a href="#">Configuration Data Commands</a> on page 283.
Include /i	With this command line parameter, an “Include” file is specified on the command line. For more information, see <a href="#">Include directive</a> on page 288. This parameter lets a single file to be specified. However, the parameter can be repeated multiple times.
Include file errors /j	With this command line parameter, you can disable error messages, generated with the Include command. For more information, see <a href="#">Include directive</a> on page 288. By default, Configuration Client generates Include file errors to the containing application.
Token value /e NEWTOKEN	With this command line parameter, the configuration data commands token can be changed from the default “%%” value. The value following the NEWTOKEN parameter can be used to determine the beginning of the command sequence. The NEWTOKEN value must be present and can contain any character except a space.
Dump working set (/DWS)	<p>The use of <a href="#">Configuration Data Commands</a> on page 283 mean the working configuration set presented to the application can look different to the data stored in the .ini file, registry or Configuration Server.</p> <p>To help troubleshooting issues that arises from this functionality, Dump working set (/DWS) command line parameter dumps the contents of the working set to a file on the local machine at the point before the containing application is notified. This creates a file named with the current data and time and the fixed text “ConfigWS.ini” for example, 20051117132110ConfigWS.ini. This file contains the complete working set contents, including included files.</p>

## Command Line Format

Command lines must follow a set of format, using spaces and quotation marks only where shown.

```
"CCEM_Install_DIR\Avaya Aura CC Elite Multichannel\Desktop\Agent\ ActiveAgent.exe" /z Agent /s 10.100.100.32 /p 29091 /a M=%M;U=%U"
```

```
"CCEM_INSTALL_DIR\Avaya Aura CC Elite Multichannel\Desktop\Agent\ ActiveAgent.exe" /z Agent /f C:\My Configuration\myFile.txt /t True /pwd false".
```

---

## Configuration Data Commands

With Configuration data commands, you can inform Configuration Client that further processing of the configuration data is required. When Configuration Client loads configuration data from the specified source, Configuration Client then performs a further processing step before making the data available to the controlling application.

Because these commands are processed at client level, these commands are available regardless of whether the data is located in a configuration file, the system registry, or Configuration Server.

---

### Token delimiter

Configuration data that must be processed further is identified by the default token “%%”. If required, you can change the token value from “%%” to something else through the command line. For more information about command line parameters, see [Command Line parameters](#) on page 280.

This token can appear at any point within the configuration data. Text that follows the token identifies the action (command) required by Configuration Client and the parameters for that action. Multiple commands can appear in a single configuration data item. For more information, see [Nested commands](#) on page 287. Commands are resolved from right to left.

Configuration data commands are supported by a limited number of keywords that give access to machine-specific variables.

Text that appears before the token, but after the item identifier is treated as a string literal.

#### Example

In the following example, DeviceName takes the configuration value “Minnie And Mickey”.

#### [MainData]

```
DeviceName = Minnie %%STRCAT( " And", " Mickey")
```

---

## Commands

Configuration Client supports the following configuration data commands. Command names are case sensitive.

When an unknown command is discovered, the result is an empty string, (“”). If this command is used to determine a piece of data used as the input for another calculation, an empty string is used.

All commands have parameters enclosed by an open or close pair of brackets.

### LOOKUP

The LOOKUP command retrieves a matching value from another section within the current configuration set. With this action, a section can be included within the configuration set that lists dynamic data to replace a static configuration value. A common example is to allow a single

configuration set to serve an entire call center for an application such as Agent. Each user that logs on can have the MyDN data item modified based on the name of the computer the agent is using.

### Syntax

```
%%LOOKUP (SECTION, ITEM)
```

Where SECTION is the section within the current configuration data that holds the match for the data specified by the ITEM variable. The SECTION and ITEM parameters can be either a string literal or a keyword.

### Example 1

The following example results in the station parameter having the value 8572:

#### [MainData]

```
Station = %%LOOKUP("Lookupdata", "SomeStationData")
```

#### [Lookupdata]

```
SomeStationData = 8572
```

### Example 2

The following example results in the station parameter having the value 8572 when the configuration data is loaded on machine BAGLEYACER:

#### [MainData]

```
Station = %%LOOKUP("Lookupdata", COMPUTERNAME)
```

#### [Lookupdata]

```
BAGLEYACER = 8572
```

### Example 3

The following example results in the station parameter having the value 8572 when the configuration data is loaded on a machine. The machine has an environment variable named MyEnvironmentVariable equal to the value BAGLEYACER.

#### [MainData]

```
Station = %%LOOKUP("Lookupdata", WINENV("MyEnvironmentVariable"))
```

#### [Lookupdata]

```
BAGLEYACER = 8572
```

## WINENV

The WINENV command retrieves a matching value from the Windows system environment.

### Syntax

```
%%WINENV( VARIABLENAME)
```

Where VARIABLENAME is the name of the system environment variable. The section parameter can be either a string literal or a keyword.

**Example**

The following example results in the station parameter having the value contained in the environment variable *MyEnvironmentVariable*.

**[MainData]**

```
Station = %%WINENV("MyEnvironment Variable")
```

**ENCRYPT**

With the ENCRYPT command, Configuration Client can encrypt or decrypt a piece of configuration data.

If the data cannot be decrypted while the configuration file is loaded, the data is presented to the user unchanged. It is assumed, the data is not encrypted and the data can be encrypted by Configuration Client at the next save.

**Syntax**

```
%%ENCRYPT (ENCRYPTEDDATA)
```

**Example**

The following example results in the user password are filled with the non-encrypted data specified.

**[MainData]**

```
UserPassword = %%ENCRYPT("9385d3fa18f4e2a1")
```

**STRCAT**

The STRCAT command joins two pieces of data together to form a single piece of data.

**Syntax**

```
%%STRCAT ( DATA1, DATA2)
```

The result is the string sum of DATA1 and DATA2.

**Example**

The following example results the PersonalPhonebook configuration data is dynamically produced from some static text and the name of the logged in user.

**[MainData]**

```
PersonalPhoneBook = %%STRCAT("c:\phonebooks\", USERNAME)
```

**SUBSTR**

The SUBSTR command extracts a piece of text from another, longer, piece of text.

**Syntax**

```
%%SUBSTR (DATA, START, COUNT)
```

The resultant data is the part of the string DATA, starting from the character START and including COUNT characters. If START is a number greater than the length of DATA or is a negative value, the result can be an empty string. If the value of START + COUNT is greater than the length of DATA, the result can be the part of the string DATA from the position START to the end of DATA.

### Example

The following example results the configuration data “The” being dynamically produced from the static text “The Rain In Spain”. The first parameter is the string, the text is extracted from. The second parameter is the start position, and the third parameter is the number of characters that are selected.

```
temp1 = %%SUBSTR("The Rain In Spain", "0", "3")
```

## Keywords

Keywords are place holders to string literal values. Configuration Client replaces these keywords when the data is passed. Keywords are case sensitive.

Keywords can be used by themselves in the configuration data set or as parameters to valid commands. When used alone, keywords must be preceded by the token delimiter. Invalid keywords are treated as empty strings.

### [MainData]

```
MyMachine = %%COMPUTERNAME
```

## Keyword descriptions

Keyword	Description
COMPUTERNAME	Configuration Client replaces the COMPUTERNAME keyword with the value of the network machine name. If the machine is unnamed, this field is empty.
USERNAME	Configuration Client replaces the USERNAME keyword with the value of the currently logged-in user name. If the logged-in user is unavailable, this field is empty.
IPADDRESS	Configuration Client replaces the IPADDRESS keyword with the value of the IP Address retrieved from the network configuration. If the machine is multihomed, the first network setting is used.
TIME	Configuration Client replaces the TIME keyword with the current machine time. This time is resolved to seconds and is formatted in accordance with the configured locale.
DATE	Configuration Client replaces the DATE keyword with the current machine date. This date is formatted in accordance with the configured locale.
CWD	The CWD keyword is replaced with the current working directory for the loading module.
WINDIR	The WINDIR keyword is replaced with the Windows directory.
WINSYSDIR	The WINSYSDIR keyword is replaced with the Windows System directory.

*Table continues...*

Keyword	Description
WITEMPDIR	<p>The WITEMPDIR keyword is replaced with the Windows temporary directory. This value is defined as:</p> <ul style="list-style-type: none"> <li>• Windows 7/WindowsXP: The function gets the temporary file path as follows: <ul style="list-style-type: none"> <li>- The path specified by the TMP environment variable.</li> <li>- The path specified by the TEMP environment variable, if TMP is not defined.</li> <li>- The Windows directory, if both TMP and TEMP are not defined.</li> </ul> </li> </ul>

---

## Literal data support

Data within quotation marks ("" ) is treated as literal data and is not processed further. Literal values can be accepted as parameters to all commands.

---

## Nested commands

With Configuration Client, multiple commands are placed on a single configuration item. Configuration commands are separated at runtime and processed in a right to left manner.

A configuration item that includes invalid command data has resultant data set to an empty string.

### Example

The following example builds a DeviceName configuration variable made from the environment variables: user name and computer name, joined by the "@" symbol.

#### [MainData]

```
DeviceName = %%STRCAT (WINENV ("USERNAME"), STRCAT ("@", COMPUTERNAME))
```

---

## Recursive loop protection

The possibility exists for a configuration token to refer when being passed. This action can potentially cause a loop that does not end gracefully. A loop can exist in a simple direct relationship or with many layers deep. To prevent these loops occurring, no resolution sequence must be more than a fixed number (20) of jumps to other configuration items. This constraint is placed on the LOOKUP command.

Single level loops can be easily detected and avoided.

### Example

#### [MainData]

```
UserPassword = %%LOOKUP ("MainData", "UserPassword")
```

---

## Resolution precedence/reentrancy

It is possible for a configuration item that is being resolved refers to another configuration item which also requires resolution. Besides, this item refers to a third item that also requires resolution. This pattern can result in many levels of indirection until a static node is reached. Configuration Client supports up to 20 levels.

Configuration set command resolution starts from the root node, and works progressively through all sub nodes.

---

## Include directive

In some scenarios, it is desirable to import other files with configuration data into the main configuration set. For example, in a hot-seating environment, a local configuration set can include a list of machine names or phone number combinations that are used in a lookup command. This list is stored in a common location such as, a network drive.

This functionality is enabled using a directive “include”.

### Example

```
#include c:\temp\computerlist.dat
```

### Rules for use

- The directive exists anywhere in the base configuration set.
- Multiple include directives are supported in the base configuration set.
- Nested “includes” are not supported, that is, an included file cannot include another file.
- Include files are processed after the base configuration is loaded, and are processed in the order Include files are listed.
- Configuration data commands are processed after the included files are added to the data set.
- Configuration data loaded from included files is not saved to the original file or with the base configuration set when the Save method is used. Changes to configuration data key or value pairs made by the application are lost when the application exits.
- Included files must follow the same key or value pair format expected for configuration data.



# Chapter 14: Interaction Data Service

---

## INCLUDE\_CONFIGURATION

---

### Interaction Data Service overview

The Interaction Data Service is the suite name for three Call Center Elite Multichannel products:

- Interaction Data Server-Voice and Presence
- Interaction Data Server-Multimedia, and
- Interaction Data Server-View

All three servers work together to gather, store, and display statistical data on Call Center Elite Multichannel voice and multimedia work items. All use a single database.

- **Interaction Data Server - Voice and Presence:** This server monitors VDNs, splits or skills, trunk groups, and agent extensions to gather detailed statistical information about all facets of a call. The server receives real time information from Avaya Communication Manager, and based on the regularity you specify, calculates statistics, such as talk and wait time averages. Data is stored in the Media Store database.

 **Note:**

When the Interaction Data Server View service is running and you restart Interaction Data Server Voice and Presence, the desktop does not reflect any agent activity or Presence status during the restart period.

- **Interaction Data Server-Multimedia:** This server receives a stream of event information from all Call Center Elite Multichannel Media Stores and Media Directors and aggregates this into real-time and historical information on all multimedia work items that flow through your call center. Data is stored in the Media Store database.
- **Interaction Data Server-View:** With this server, you can access the statistical data generated by Interaction Data Server-Voice and Presence and Interaction Data Server-Multimedia and to display that data on individual client PCs. Interaction Data Server-View is currently used by the Call Center Elite Multichannel Desktop application, and can also be used by developers to build own client applications.

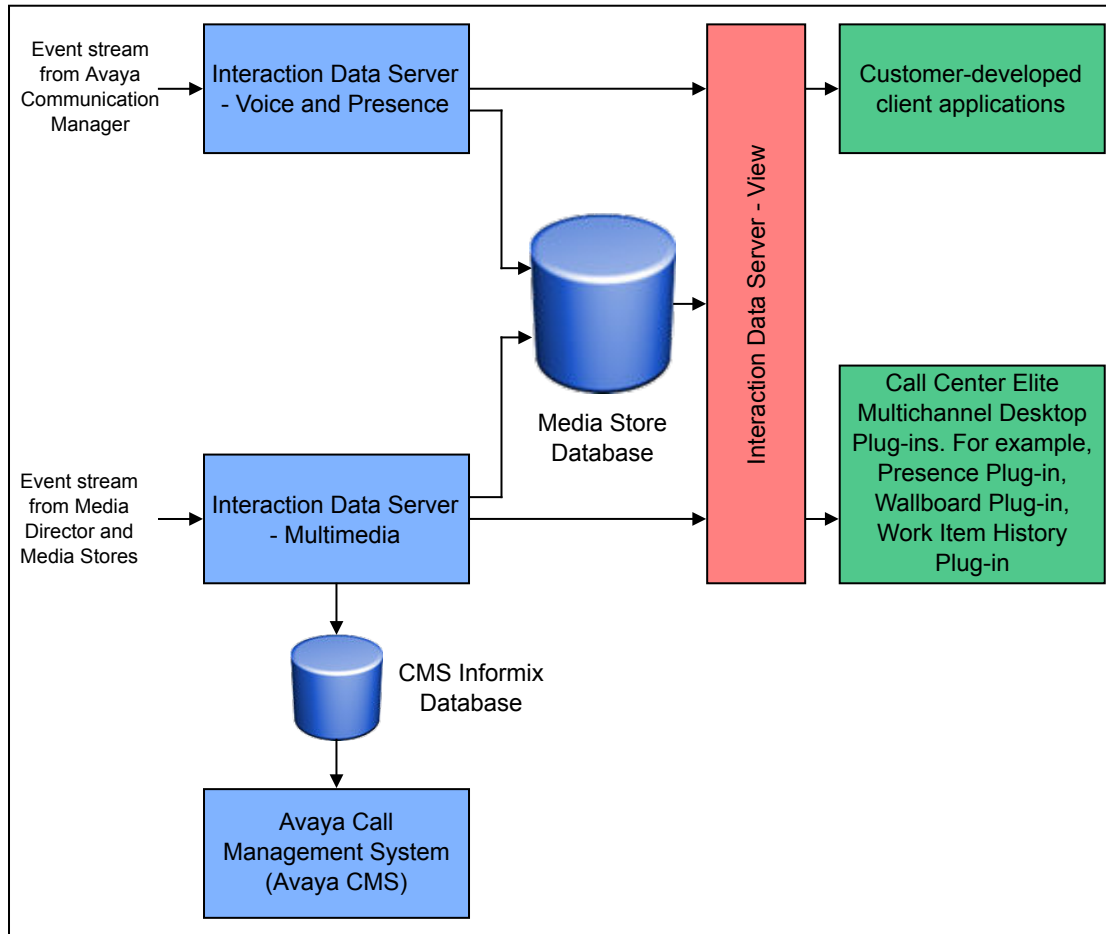

Call Center Elite Multichannel also makes some of the multimedia reporting data held within the Interaction Data Service easily available to the Avaya Call Management System (Avaya CMS) package. For more information, see [Reporting from AvayaCMS](#) on page 322.

**\* Note:**

Interaction Data Server uses Media Store database and not Active interaction database.

## Setting up Interaction Data Service

### About this task

To set up your Interaction Data Service environment, perform the following steps:

### Procedure

1. Configure your Avaya Communication Manager to add UCID to the event records and pass on the UCID to the Telephony Server.
2. Install Interaction Data Service that includes Interaction Data Server-Voice and Presence, Interaction Data Server - Multimedia and Interaction Data Server-View.

3. Create the Media Store database.
4. Configure Interaction Data Server - Voice and Presence, Interaction Data Server-Multimedia and Interaction Data Server-View.
5. Start Interaction Data Server-Voice and Presence, Interaction Data Server-Multimedia and Interaction Data Server-View (in the specified order).

## Avaya Communication Manager and Telephony Server

The Media Store database depends on the Universal Call ID (UCID) to relate different tables in the database.

For the database to work correctly, each Avaya Communication Manager must have “Create UCID” turned on, and a valid UCID network node ID.

You must also configure the Communication Manager to pass the UCID to the Telephony Server (“Send UCID to ASAI?” is set to yes).

---

## Configuring Interaction Data Server-Voice and Presence

### Before you begin

Interaction Data Server-Voice and Presence must be installed. For instructions on how to install Interaction Data Server-Voice and Presence, see *Installing Avaya Aura® Call Center Elite Multichannel*.

### Procedure

1. In the Windows explorer, navigate to the `\Avaya Aura CC Elite Multichannel \Server\Interaction Data Server - Voice and Presence` directory.
2. Open the `AIDServer.ini` file in a text editor, such as Notepad.

Use the definitions described in the [Interaction Data Server - Multimedia parameter descriptions](#) on page 299 table to define your configuration data.

 **Note:**

Do not change the section names or parameter names.

## Interaction Data Server - Voice and Presence parameter descriptions

Name	Description
[Error Logging]	
Error Log Level	<p>The value that determines what level of error detail are saved in the error log:</p> <ul style="list-style-type: none"> <li>• 0=No error logging.</li> <li>• 1=Logs fatal, major, minor and trace information.</li> <li>• 2=Logs fatal, major and minor errors.</li> </ul>





*Table continues...*

Name	Description
	<ul style="list-style-type: none"> <li>• 4=Logs fatal and major errors.</li> <li>• 8=Logs fatal errors only.</li> </ul> <p>Besides, there is another error log level available. This error log enables you to create log files that do not override each other every time the maximum log file size limit exceeds. This logging level is designed for diagnostic purposes only and can be achieved by adding 128 to one of the logging level values mentioned. For example, if you specify Error Log Level=129, new error log files are continuously created for this application. This new error log file contains fatal, major, minor and trace information.</p>
<b>Error Log File Path</b>	The directory path for saving error log files. By default, this parameter is blank, and automatically sets the path to the application current working folder that is, the same folder as the application executable.
<b>Error Log Extension</b>	The extension of error log files for this application. Extension refers to part of the file name, usually the name of the application and the file type extension for example, .log. The application automatically precedes the default extension with the day of the week for example, Mon, Tue when it creates the error logs.
<b>Maximum Error Log File Size KB</b>	The maximum amount of information, in kilobytes, that are stored in an error log file before the information is archived and a new file is created. The default is 1000. The minimum, you can set this to is 100. Note: The archive can store only one log file. If a second error log reaches the specified maximum size, it overrides the previously archived file. If, the diagnostic testing error log level is selected in Error Log Level, a new file with a new name is created every time the maximum log file size limit is reached. The diagnostic testing error log level is achieved by adding 128 to any one of the other error log values.
<b>[Settings]</b>	
<b>Interaction Data Server ID</b>	A unique number that identifies the Interaction Data Server-Voice and Presence.
<b>Interaction Data Server Name</b>	A user-specified, user-friendly name for the Interaction Data Server-Voice and Presence. Note: Do not include spaces.



*Table continues...*

Name	Description
<b>Interaction Data Server Port</b>	The port number the Interaction Data Server-Voice and Presence uses to accept connections from clients and other servers. The default is 29090.
<b>Statistical Data Cache Interval Seconds</b>	The regularity, in seconds, in which the server internally caches statistical data. Note: The suggested value is 1 or 2. Do not exceed 5.
<b>[ASM Client To Be Loaded] - Reserved for future use.</b>	
<b>[Switchx]</b>	
<b>Switch ID</b>	The ID number of the switch, the Interaction Data Server-Voice and Presence is connected to. The number must be unique. The switch ID is particularly important in complex configurations, where there is a network of Interaction Data Server - Voice and Presence servers receiving information from multiple Avaya switches.
<b>Primary Link Name</b>	The name of the primary link this application can use to connect to the Avaya Telephony Server and switch.
<b>Primary User Name</b>	The user name required to gain access to the primary link.
<b>Primary User Password</b>	The password associated with above user name. By default, the Call Center Elite Multichannel application can encrypt this data.  For more information, see <i>Installing Avaya Aura® Call Center Elite Multichannel</i> .
<b>Database Server Name</b>	The name of the server on which the database is located.
<b>Database Name</b>	The name of the database. This database is automatically named as ASMSControl when the database script runs.
<b>Database User Name</b>	The user name required to gain access to the database. This database is automatically named as ASMSControl when the database script runs.
<b>Database User Password</b>	The password associated with the user name. When creating new databases, the default is: CCEUser0 before encryption. For encryption information, see <i>Installing Avaya Aura® Call Center Elite Multichannel</i> .
<b>Log Event</b>	The value that determines if event logging is enabled or not. False= disabled, True=enabled.
<b>Log Interaction Summary</b>	The value that determines if interaction summary logging is enabled or not. False= disabled, True=enabled.

*Table continues...*

Name	Description
	<p> <b>Note:</b></p> <p>If event logging (Log Event) is enabled, interaction summary logging must also be enabled.</p>
<b>Log Call Summary</b>	<p>The value that determines if call summary logging is enabled or not. False= disabled, True=enabled.</p> <p> <b>Note:</b></p> <p>If event logging (Log Event) is enabled, call summary logging must also be enabled.</p>
<b>Log Statistics Data</b>	<p>The value that determines if statistical data logging is enabled or not. False= disabled, True=enabled.</p> <p> <b>Note:</b></p> <p>The setting for statistical data logging is not dependent on event logging (Log Event).</p>
<b>Log User Data</b>	<p>The value that determines if user data logging is enabled or not. False= disabled, True=enabled.</p> <p> <b>Note:</b></p> <p>The setting for statistical data logging is not dependent on event logging (Log Event).</p>
<b>Service Level Time Seconds</b>	<p>The time, in seconds, logged-in agents are expected to take to answer calls. Service Level Time Seconds is a switch-wide service level setting for VDNs or split or skills that do not have own specific service levels. For example: Service Level Time Seconds=15.</p>
<b>VDN</b>	<p>The VDNs to be monitored by the Interaction Data Server-Voice and Presence. Note: Separate VDNs with commas. Do not include spaces. Use a hyphen to specify a range. For example: VDN=448-4485,4542,4819,4830</p> <p>To assign a specific service level to a VDN, separate the VDN number and the service level by a full colon. For example: VDN=448-4485,4542:20,4819:30,4830</p> <p>In this example, VDNs 4481-4485 and 4830 use the service level value set for the switch (see Service Level Time Seconds). VDN 4542 has a service level of 20 seconds and 4819 has a service level of 30 seconds.</p>
<b>ACD Split</b>	<p>The hunt group extension numbers that relate to your split or skills to be monitored by the Interaction Data Server-Voice and Presence. Note: Separate</p>

*Table continues...*

Name	Description
	<p>hunt group extension numbers with commas. Do not include spaces. Use a hyphen to specify a range. To assign a specific service level to a VDN, separate the VDN number and the service level by a full colon.</p> <p>For example: ACD Split=8001,8002,8003:25,8004:10,8005</p> <p>In this example, hunt group extension numbers 8001, 8002 and 8005 use the service level value set for the switch (see Service Level Time Seconds). Hunt group extension number 8003 has a service level of 25 seconds and 8004 has a service level of 10 seconds.</p>
<b>Station</b>	<p>The station extensions to be monitored by the Interaction Data Server-voice and Presence.</p> <p> <b>Note:</b> Separate extensions with commas. Do not include spaces. Use a hyphen to specify a range. For example: Station=4401-4424,4637.</p>
<b>Trunk Group</b>	<p>The trunk groups to be monitored by the Interaction Data Server-Voice and Presence.</p> <p> <b>Note:</b> Separate groups with commas. Do not include spaces. Use a hyphen to specify a range.</p>
<b>Shift Start Times</b>	<p>The start times for shifts throughout the day. A shift can be any value between 1 to 24 hours. At the end of each shift, statistical data are written to the database and then reset for the next shift calculation. The times are used in the order the times are entered. If shift times are missing, a default shift is assumed that covers a single day that is, shift starts at 00:00 and ends at 23:59.</p> <p> <b>Note:</b> Separate start times with commas.</p> <p>For example: Shift Start Times = 08:00, 14:00, 22:30, 03:00</p> <p>This example splits the day into four shifts. Shift 1 starts at 08:00 and run until the start of shift 2 at 14:00. Shift 2 runs until the start of shift 3 at 22:30. Shift 3 runs until the start of shift 4 at 03:00 the next day. Shift 4 runs until shift 1 starts again at 08:00. The same shift times are available every day.</p>

*Table continues...*

Name	Description
<b>Statistic Interval Minutes</b>	<p>The time, in minutes, between statistic calculations. The interval can be any value between 1 to 60 minutes. Values outside this range cannot be accepted. At the end of each interval, statistical data are written to the database, and then reset for the next interval calculation.</p> <p>Where possible, select an interval that is a divisor of 60 minutes. Where a value is chosen that is not a divisor of 60 minutes, the result can be a smaller final period in the hour. For example, if 13 minutes is chosen, this time results in four intervals of 13 minutes, and one final interval of 8 minutes.</p> <p>If the value is missing or invalid, the interval is set to 5 minutes.</p> <p><b>* Note:</b> Settings for Time Zones which are not a multiple of full hours.</p> <p><b>* Note:</b> To setup a system running in a Time Zone that is not a multiple of a full hour, for example India at GMT + 5:30, the parameter Statistics Interval Minutes in the configuration file (AIDServer.ini) of Interaction Data Server-Voice and Presence must be reconfigured.</p> <p><b>* Note:</b> The default value 60 minutes must be changed to maximum 30 minutes for TimeZones which differ by x:30 minutes to GMT and maximum 15 minutes for TimeZones which differ by x:15 minutes GMT. This ensures that the system collects data with the appropriate details.</p>
<b>Polling Agent Interval Seconds</b>	<p>How frequently, in seconds, the application polls for agent mode status. To reduce the network traffic, increase this number.</p> <p><b>* Note:</b> To turn this feature off, use 0.</p>
<b>Polling Trunk Group Interval Seconds</b>	<p>How frequently, in seconds, the application polls for trunk group status. Note: To turn this feature off, use 0.</p>

*Table continues...*



Name	Description
<b>Force Agent Polling</b>	<p>If enabled (set True), this parameter forces the application to poll the switch for agent state information.</p> <p>If disabled, this parameter (set False) and Enable Agent Events is also disabled, Interaction Data Server-Voice and Presence ignores False value and automatically poll the switch using the polling interval defined by Polling Agent Interval Seconds.</p>
<b>Enable Agent Events</b>	<p>If enabled (set True), this parameter grants the Interaction Data Server-Voice and Presence to automatically receive agent state change information (events) from the Communication Manager.</p> <p>If this parameter is disabled (set False), Interaction Data Server - Voice and Presence automatically polls the switch for agent state information using the polling interval defined by the Polling Agent Interval Seconds.</p> <p> <b>Note:</b> Interaction Data Server - Voice and Presence polls the switch even if the Force Agent Polling parameter is disabled.</p>
<b>Automatically Add Devices</b>	<p>If enabled (set True), this parameter forces Interaction Data Server-Voice and Presence to query the switch to determine if any new devices such as, stations, VDNs and skills are added to the switch that are not added to the configuration. If the parameter finds a new device on the switch that is currently not monitoring, Interaction Data Server-Voice and Presence adds the device to the configuration.</p>
<b>Validate Each Device Type On Startup</b>	<p>If enabled (set True), this parameter forces Interaction Data Server-Voice and Presence to query the switch to determine if the devices you have added to the configuration are listed under the correct device type that is, station, VDN, split or skill, and trunk group. If Interaction Data Server - Voice and Presence finds a device type is wrong, Interaction Data Server - Voice and Presence does not monitor the device.</p>
<b>[Other AIDServer x]</b>	
<b>Interaction Data Server ID</b>	A unique number that identifies the Interaction Data Server-Voice and Presence.
<b>Interaction Data Server Name</b>	A user-specified, user-friendly name for the Interaction Data Server-Voice and Presence.

*Table continues...*

Name	Description
	<p> <b>Note:</b></p> <p>Do not include spaces.</p>
<b>Interaction Data Server IP</b>	The IP address of the Interaction Data Server-Voice and Presence.
<b>Interaction Data Server Port</b>	The port number the Interaction Data Server-Voice and Presence uses to accept connections from clients and other servers. The default is 29090.
<b>Switch IDs</b>	<p>The ID numbers of the switches the Interaction Data Server - Voice and Presence is connected to.</p> <p>If you want the Interaction Data Server - Voice and Presence to monitor information for more than one switch, you must copy and paste the [Switchx] section and modify it accordingly. If you want the Interaction Data Server - Voice and Presence to accept connections from more than one other Interaction Data Server-Voice and Presence, you must copy and paste the [Other Interaction Data Server x] section and modify it accordingly. Never delete a default configuration parameter. If you don't need to enter a value, leave the line blank, for example, VDN=</p>

## Configuring Interaction Data Server - Multimedia

### Before you begin

Interaction Data Server-Multimedia must be installed. For instructions on how to install Interaction Data Server-Multimedia, see *Installing Avaya Aura® Call Center Elite Multichannel*.

### Procedure

1. In the Windows explorer, navigate to the `\Avaya Aura CC Elite Multichannel \Server\Interaction Data Server - Multimedia` directory.
2. Open the `ASIDSMultimedia.ini` file in a text editor, such as Notepad.

Use the definitions described in the [Interaction Data Server - Multimedia parameter descriptions](#) on page 299 table to define your configuration data.

 **Note:**

Do not change the section names or parameter names.

## Interaction Data Server - Multimedia parameter descriptions

Name	Description
<b>[Service Plug In Host]</b>	
<b>Service Display Name</b>	The text that displays for this service under the Name column of the Microsoft Windows Services screen. The default value is: AS Interaction Data Server-Multimedia Service Command Line. Leave this parameter blank. By default, Service Host Plug-in can source the configuration data from the same working folder that contains the application executable.
<b>Service Description</b>	The text that displays for this service under the Description column of the Microsoft Windows Services screen. The default is: The IDS MultiMedia is a component working with a single focus on the multimedia staff.
<b>Service Startup State</b>	A value that determines the state of the service when it is installed. 0=Disabled, 1=Manual, 2=Automatic.
<b>[Error Logging]</b>	
<b>Error Log Level</b>	<p>The value that determines what level of error detail is saved in the error log:</p> <ul style="list-style-type: none"> <li>• 0=No error logging.</li> <li>• 1=Logs fatal, major, minor and trace information.</li> <li>• 2=Logs fatal, major and minor errors.</li> <li>• 4=Logs fatal and major errors.</li> <li>• 8=Logs fatal errors only.</li> </ul> <p>Moreover, there is another error log level, which enables you to create log files that donot override each other every time the maximum log file size limit exceeds. This logging level is designed for diagnostic purposes only and can be achieved by adding 128 to one of the logging level values mentioned above. For example, if you specify Error Log Level=129, new error log files is created for this application that contains fatal, major, minor and trace information.</p>
<b>Error Log File Path</b>	The directory path for saving error log files. By default, this parameter is blank, which automatically sets the path to the application current working folder that is, the same folder as the application executable.

*Table continues...*

Name	Description
<b>Error Log File Extension</b>	The extension of error log files for this application. Extension refers to part of the file name usually the name of the application and the file type extension. For example, .log. The application automatically precedes the default extension with the day of the week for example, Mon, Tue, when the application creates error logs.
<b>Maximum Error Log File Size KB</b>	<p>The maximum amount of information, in kilobytes, that will be stored in an error log file before the information is archived and a new file is created. The default is 1000. The minimum, you can set this is 100.</p> <p> <b>Note:</b></p> <p>The archive stores only one log file. If a second error log reaches the specified maximum size, it overrides the previously archived file. If, the diagnostic testing error log level is selected in Error Log Level, a new file with a new name is created every time the maximum log file size limit is reached. The diagnostic testing error log level is achieved by adding 128 to any one of the other error log values.</p>
<b>[Server Identifier]</b>	
<b>Server Instance Friendly Name</b>	Any name you want to display for this application within Call Center Elite Multichannel Control Panel.
<b>Server Instance ID</b>	A unique identifier for the server application, which is created automatically when it runs for the first time.
<b>Server Instance Type</b>	An ID used by other applications to determine what type of component the applications are communicating with.
<b>[Application Management Service]</b>	
<b>Multicast IP</b>	The IP address that is used for multicasting between applications. When an application starts, the application joins this multicast address and receive packet information from the Application Management Director. The default is 239.29.9.67.
<b>Multicast Port</b>	The port number that is used for multicasting between applications. The default is 29075.
<b>Enable Multicast</b>	A value that determines whether multicasting is used to locate the Application Management Director. True=enabled, False= disabled. The default is True.
<b>Application Management Director URL List</b>	If multicasting is disabled, these URLs are used to find the Application Management Directors set up in

*Table continues...*

Name	Description
	your contact center. Items are separated by commas and follow the format: IP address:port number, IP address:port number.
<b>Management Object URL</b>	The URL used by Call Center Elite Multichannel Control Panel to connect to the remote management object. The URL must use the following format: channeltype:// fullyqualifiedcomputername:port/uri. If the entry is empty, a default URL is created automatically.
<b>[Client Connections]</b>	
<b>IP Address</b>	The local IP address for accepting incoming client connections.
<b>IP Port</b>	The local IP port for accepting incoming client connections.  Allow Multicast: A value that determines whether multicasting of the connection information is enabled or not. True=enabled, False=disabled. Enable Trace. A value that determines whether information is logged to the log file. True=enabled, False=disabled.
<b>Broadcast Interval In Seconds</b>	The time, in seconds, connection information is multicasted.
<b>Multicast IP</b>	The IP address that is used for multicasting the connection information. The default is 239.29.9.67.
<b>Multicast Port</b>	The port number that is used for multicasting the connection information.
<b>Receive Buffer Length</b>	The buffer size for incoming messages. The default is 20000.
<b>[Plug In Assembly List]</b>	
	This section lists all loadable generic plug-ins. Each entry has the format "Friendly name=Plug-in section name". The plug-in section name points to and is the same as the section in the file that contains configuration data for that plug-in. For example: IDS MMAE Realtime Engine = IDS MMAE Realtime Engine IDS MMAE CMS Engine = IDS MMAE CMS Engine.
<b>[IDS MMAE Realtime Engine]</b>	
<b>Plugin ID</b>	A globally unique identifier (GUID) that identifies this plug-in.
<b>Assembly File Name</b>	The name of the plug-in file to be loaded. If the plug-in is not located in the default file path, which is the same folder as the host application, also specify the

*Table continues...*

Name	Description
	file path. For this plug-in, use: ASIDSMMAERealtimePlugin.dll
<b>Receive Buffer Length</b>	The buffer size for incoming messages. The default is 20000.
<b>Statistic Interval</b>	<p>The time, in minutes, between statistic calculations. The interval can be any value between 1 to 60 minutes. Values outside this range is not accepted. The default is 15. At the end of each interval, statistical data is written to the database and then reset for the next interval calculation. Where possible, select an interval that is a divisor of 60 minutes. Where a value is chosen that is not a divisor of 60 minutes, the result can be a smaller final period in the hour. For example, if 13 minutes is chosen, this results in four intervals of 13 minutes and one final interval of 8 minutes.</p> <p>If the value is missing or invalid, the interval is set to 5 minutes.</p>
<b>Shift Start Times</b>	<p>The start times for shifts throughout the day. A shift can be any value between 1 to 24 hours. At the end of each shift, statistical data is written to the database, and then reset for the next shift calculation. The times are used in the order the times are entered. If shift times are missing, a default shift is assumed, which covers a single day that is, that starts at 00:00 and ends at 23:59. Note: Separate start times with commas.</p> <p>For example: Shift Start Times=08:00, 14:00, 22:30, 03:00</p> <p>This example splits the day into four shifts. Shift 1 starts at 08:00 and run until the start of shift 2 at 14:00. Shift 2 runs until the start of shift 3 at 22:30. Shift 3 runs until the start of shift 4 at 03:00 the next day. Shift 4 runs until shift 1 starts again at 08:00. The same shift times continues every day.</p>
<b>Enable Error Logging</b>	With this setting, you can write plug-in specific error information to the application error log files. True=enabled, False=disabled.
<p><b>[IDS MMAE CMS Engine]</b></p> <p>This section configures the Multimedia CMS Plug-in. Plug-in ID. A globally unique identifier (GUID) that identifies this plug-in.</p>	
<b>Server Instance Id</b>	The server instance ID of the media store referenced in the mentioned GUID that generates data for CMS.

*Table continues...*

Name	Description
<b>Assembly File Name</b>	The name of the plug-in file to be loaded. If the plug-in is not located in the default file path, which is the same folder as the host application, also specify the file path. For this plug-in, use: ASIDSCMSPlugin.dll
<b>Database Server Name</b>	The name or TCP/IP address of the server on which the Avaya CMS Informix database is located.
<b>Database User Name</b>	A valid user name for the CMS Informix database.
<b>Database User Password</b>	The password associated with the user name.
<b>IDS MMAE URL</b>	The URL for Interaction Data Server-Multimedia. The URL must use the following format: <code>gtcp://localhost:29077/InteractionDataServiceMultimedia.rem.</code>
<b>Enable Error Logging</b>	With this setting, you can write plug-in specific error information to the application error log files. True=enabled, False=disabled.
<b>Fire Test Mock Event</b>	Set to False. This is used for development only

## Configuring Interaction Data Server - View

### About this task

#### Before you begin

Before you begin configuring, the Interaction Data Server - View must be installed. For instructions on how to install Interaction Data Server - View, see the *Installing Avaya Aura® Call Center Elite Multichannel. Installing Avaya Aura® Call Center Elite Multichannel* can be downloaded from the Avaya Support website: <http://support.avaya.com>.

To configure Interaction Data Server - View:

#### Procedure

1. Click the Start button on the Windows taskbar and select **Programs > Avaya Aura CC Elite Multichannel > Server > Interaction Data Server - View > Edit ASIDSView.ini**.
2. Use the definitions in *Interaction Data Server - View parameter descriptions* table to define your configuration data.

#### Note:

Do not change section names or parameter names.

## Interaction Data Server - View parameter descriptions

Name	Description
[Service Plug In Host]	

Table continues...

Name	Description
<b>Service Display Name</b>	The text that displays for this service under the Name column of the Microsoft Windows Services screen. The default value is: AS Interaction Data Server - View
<b>Service Command Line</b>	Leave this parameter blank. By default, Service Host Plug-in will source its configuration data from the same working folder that contains the application executable.
<b>Service Description</b>	The text that displays for this service under the Description column of the Microsoft Windows Services screen. The default is: IDS View is a service for extracting the aggregated real time and historical data from the IDS suite
<b>Service Startup State</b>	A value that determines the state of the service when it is installed. 0=Disabled, 1=Manual, 2=Automatic.
<b>[Error Logging]</b>	
<b>Error Log Level</b>	<p>The value that determines what level of error detail will be saved in the error log: 0=No error logging takes place, 1=Logs fatal, major, minor and trace information, 2=Logs fatal, major and minor errors, 4=Logs fatal and major errors, 8=Logs fatal errors only.</p> <p>There is also another error log level, which enables you to create log files that don't override each other every time the maximum log file size limit is reached. This logging level is designed for diagnostic purposes only and can be achieved by adding 128 to one of the logging level values mentioned above. For example, if you specify Error Log Level=129, new error log files will be continuously created for this application that contain fatal, major, minor and trace information.</p>
<b>Error Log File Path</b>	The directory path for saving error log files. By default, this parameter is left blank, which automatically sets the path to the application's current working folder (the same folder as the application executable).
<b>Error Log File Extension</b>	The extension of error log files for this application. Extension refers to part of the file name (usually the name of the application) and the file type extension (for example, .log). The application will automatically precede the default extension with the day of the week (for example, Mon, Tue) when it creates its error logs.

*Table continues...*



Name	Description
<b>Maximum Error Log File Size KB</b>	The maximum amount of information, in kilobytes, that will be stored in an error log file before it is archived and a new file is created. The default is 1000. The minimum you can set this to is 100. Note: The archive will only store one log file. If a second error log reaches the specified maximum size, it overrides the previously archived file. If, however, the diagnostic testing error log level is selected in Error Log Level (this is achieved by adding 128 to any one of the other error log values), a new file with a new name is created every time the maximum log file size limit is reached.
[Server Identifier]	
<b>Server Instance Friendly Name</b>	Any name you want to display for this application within Call Center Elite Multichannel Control Panel.
<b>Server Instance ID</b>	A unique identifier for the server application, which is created automatically when it runs for the first time.
<b>Server Instance Type</b>	An ID used by other applications to determine what type of component they are communicating with.
[Application Management Service]	
<b>Multicast IP</b>	The IP address that will be used for multicasting between applications. When an application starts, it will join this multicast address and receive packet information from the Application Management Director. The default is 239.29.9.67.
<b>Multicast Port</b>	The port number that will be used for multicasting between applications. The default is 29075.
<b>Enable Multicast</b>	A value that determines if multicasting will be used to locate the Application Management Director or not. True=enabled, False=disabled. The default is True.
<b>Application Management Director URL List</b>	If multicasting is disabled, these URLs are used to find the Application Management Directors set up in your contact center. Items are separated by commas and follow the format: IP address:port number, IP address:port number etc.
<b>Management Object URL</b>	The URL used by Call Center Elite Multichannel Control Panel to connect to the remote management object. The URL must use the following format: channeltype://fullyqualifiedcomputername:port/uri. If the entry is empty, a default URL is automatically created: <code>gtcp://fullyqualifiedlocalcomputername:29069/XMLServer.rem.</code>
[Client Connections]	

*Table continues...*

Name	Description
<b>IP Address</b>	The local IP address for accepting incoming client connections.
<b>IP Port</b>	The local IP port for accepting incoming client connections.
<b>Allow Multicast</b>	A value that determines whether multicasting of the connection information is enabled or not. True=enabled, False=disabled.
<b>Enable Trace</b>	A value that determines whether information is logged to the log file. True=enabled, False=disabled.
<b>Broadcast Interval In Seconds</b>	How often, in seconds, connection information is multicasted.
<b>Multicast IP</b>	The IP address that will be used for multicasting the connection information. The default is 239.29.9.67.
<b>Multicast Port</b>	The port number that will be used for multicasting the connection information.
<b>Receive Buffer Length</b>	The buffer size for incoming messages. The default is 20000.
<b>[Plug In Assembly List] This section lists all loadable generic plug-ins. Each entry has the format "Friendly name=Plug-in section name". The plug-in section name points to (and is the same as) the section in the file that contains configuration data for that plug-in. For example: IDS View Engine = IDS View Engine</b>	
<b>[IDS View Engine]</b>	
<b>Plugin ID</b>	A globally unique identifier (GUID) that identifies this plug-in.
<b>Assembly File Name</b>	The name of the plug-in file to be loaded. If the plug-in is not located in the default file path (the same folder as the host application), also specify the file path. For this plug-in, use: ASIDSViewPlugin.dll.
<b>Enable Error Logging</b>	A setting that allows you to write plug-in specific error information to the application's error log files. True=enabled, False=disabled.
<b>Multicast IP</b>	The multicast IP address for sending out notifications. The default is 239.29.9.67.
<b>Multicast Port</b>	The multicast port address for sending out notifications. The default is 29084.
<b>IDS Voice and Presence IP</b>	The IP address of Interaction Data Server - Voice and Presence.
<b>IDS Voice and Presence Port</b>	The IP port of Interaction Data Server - Voice and Presence. The default is 29090.

*Table continues...*

Name	Description
<b>IDS MMAE URL</b>	The URL for connecting to Interaction Data Server - Multimedia. The URL must use the following format: gtcp://localhost:29077/InteractionDataServiceMultimedia.rem. If this parameter is empty, the next four parameters are used to form the URL.
<b>IDS MMAE Channel Type</b>	The type of channel to use to connect to Interaction Data Server - Multimedia. Valid values are 'ipc', 'tcp' and 'gtcp'. If the IDS MMAE URL parameter contains data, this entry is ignored. The default value is gtcp.
<b>IDS MMAE IP</b>	The IP address of Interaction Data Server - Multimedia. If the IDS MMAE URL parameter contains data, this entry is ignored.
<b>IDS MMAE Port</b>	The IP port of Interaction Data Server - Multimedia. If the IDS MMAE URL parameter contains data, this entry is ignored.
<b>IDS MMAE Remote Factory URI</b>	The URI (Uniform Resource Identifier) of the remote communication object factory on Interaction Data Server - Multimedia. In this case, the URI is the name of the object factory: InteractionDataServiceMultimedia.rem. If the IDS MMAE URL parameter contains data, this entry is ignored.
<b>Database Connection String</b>	<p>An ADO connection string that will be used for database connectivity. If this parameter is empty, the Database Server Name, Database Name and Database User Name parameters are used to form the connection string. Encrypt this string if it contains a password by using the %%ENCRYPT command.</p> <p>For more information, see <i>Installing Avaya Aura® Call Center Elite Multichannel</i>.</p> <p> <b>Note:</b></p> <p>If you need to change the database settings, like Database Server Name, Database Name, Database User Name, or Database User Password, for example, you want to connect to another database, you need to delete the Database Connection String and change the values of Database Server Name, Database Name, Database User Name, or Database User Password.</p>
<b>Database Server Name</b>	In a case of a default instance installation of the MS SQL Server, configure the hostname or IP address of the server on which the database is located. If the

Table continues...

Name	Description
	MS SQL Server is installed with a named instance installation, configure the hostname or IP address and the instance name of the server on which the database is located. For example, <IP-Address> \<instance name> or <hostname>\<instance name>.
<b>Database Name</b>	The name of the database. This is automatically named ASMSControl when the database script is run.
<b>Database User Name</b>	The user name required to gain access to the database. This is automatically named ASMSControl when the database script is run.
<b>Database User Password</b>	The password associated with the above user name. When creating new databases, the default is: CCEUser0 before encryption. For encryption information, see <i>Installing Avaya Aura® Call Center Elite Multichannel</i> .
<b>Polling IDS Voice and Presence Interval Seconds</b>	How often, in seconds, Interaction Data Server - View polls Interaction Data Server - Voice and Presence for status information. The default is 10.
<b>Maximum History Entry</b>	The maximum number of history entries that are returned by Interaction Data Server - View. The default is 100. If you enter 0, Interaction Data Server - View will return all the records retrieved from the database.

---

## Client Applications

Interaction Data Server - View allows you to access the statistical data generated by Interaction Data Server - Voice and Presence, and Interaction Data Server - Multimedia and to display that data on individual client PCs. Interaction Data Server - View is currently used by the Call Center Elite Multichannel Desktop application, and it can also be used by developers to build their own client applications.

## Client Connections

Clients will connect to Interaction Data Server - View using the remote technology already deployed throughout Call Center Elite Multichannel. Interaction Data Server - View defines a remote object for this communication, called `IDSViewClientWrapper`, which has the methods and events to allow communication between the two points. This wrapper simplifies connection to Interaction Data Server - View Client, exposing only those methods and events relevant to a client connection. Note that the Interaction Data Server - View Client object also has methods and events for its communication with Interaction Data Server - View which should not be used by a client.

Transfer of data to the clients is a mixture of one-to-one communication and (where at all possible) multicast.

## Method return codes

All methods from the client to Interaction Data Server - View return a long value error code. In the method description this is referred to as `enIDSViewClientReturn`. For more information on error code values, see *Enumerations* section.

## Related topic

[Enumerations](#) on page 322.

## Related Links

[Enumerations](#) on page 322

## Preamble

Begin by creating a new `IDSViewClientWrapper` object. This creation allows the client to decide from which Interaction Data Server to obtain data and whether the status change messages can be received via multicast or sent to the client directly.

## Syntax:

```
public IDSViewClientWrapper(
    IDSCClientInfo iDSViewClientInfo,
    String strMulticastIP,
    Int32 nMulticastPort,
    String iDSViewURL,
    Boolean bSendByMulticast)
```

Where:

- *iDSViewClientInfo* contains the basic information for an Interaction Data Server - View Client – the `ServerInstanceId` and `ServerInstanceType` GUIDs
- *strMulticastIP* is the multicast IP address for receiving multicast notifications.
- *nMulticastPort* is the multicast port for receiving multicast notifications.
- *iDSViewURL* the URL of the Interaction Data Server - View remoting object.
- *bSendByMulticast* specifies whether the notification message will be sent through IP multicasting in which case the multicast parameters above must be passed.

## Client Connection events

The following events become available and are fired on creation or at other times during the client connection to `IDSViewClientWrapper`.

### ***OnConnected***

This event occurs, with no parameters, when Interaction Data Server - View Client successfully connects to Interaction Data Server - View.

### ***OnDisconnect***

This event occurs, with no parameters, when Interaction Data Server - View Client disconnects from Interaction Data Server - View.

### ***OnInternalError***

This event occurs when Interaction Data Server - View Client/Interaction Data Server - View comes across an unexpected error.

#### **Event syntax:**

```
OnInternalError (String errorMessage)
```

### ***OnIDSMultimediaStatusChanged***

This event occurs when Interaction Data Server - View connects or disconnects from the Interaction Data Server - Multimedia database.

#### **Event syntax:**

```
OnIDSMultimediaStatusChanged (enum enIDSMultimediaStatus)
```

Where Connected = 1, Disconnected = 2 indicates the current status of the connection.

### ***OnIDSVoiceStatusChanged***

This event occurs when Interaction Data Server - View connects or disconnects from the Interaction Data Server - Voice and Presence.

#### **Event syntax:**

```
OnIDSVoiceStatusChanged (enum enIDSVoiceStatus)
```

Where,

- Connected = 1 and Disconnected = 2 indicates the current status of the connection.

### ***RegisterIDSViewClient***

Use this method after creating an `IDSViewClientWrapper` object before requesting and receiving notifications.

#### **Method syntax:**

```
enIDSViewClientReturn RegisterIDSViewClient (Int32 nCheckRegInSecond)
```

Where,

- *nCheckRegInSecond* is the interval in seconds after which the connection between Interaction Data Server - View and Interaction Data Server - View Client is checked. The default value is 10 seconds.

### ***UnRegisterIDSViewClient***

Use this method to stop using a `IDSViewClientWrapper` object for requesting and receiving notifications. Note that this method clears all set notifications automatically.

There are no parameters for this method.

#### **Method syntax:**

```
enIDSViewClientReturn UnregisterIDSViewClient()
```

---

## Real Time Reporting Data

This section describes the real-time reporting data available to clients. Some of this data will follow the request/response message flow and others will follow the asynchronous notification pattern via the multicast functionality.

**\* Note:**

The following method and event descriptions have been split into logical functional groups (device, agent etc) however these methods and events are presented in a single object exposed to the client by IDViewClientWrapper.

### Real Time Reporting Data for Devices

Clients use the following methods to set or clear interest of notification in a specific device. When interest is requested then status updates will be sent to the client.

Interaction Data Server - Voice and Presence holds the last message about all devices. When a new client connects and adds the requirement for notification about a specific device, this stored message is forwarded immediately.

---

## Device methods

---

### SetDeviceStatusNotification

**Description:**

The client calls this method to signal to IDViewClientWrapper that it requires status notification on the device or devices listed. The client is able to specify multiple devices in this call.

**Method syntax:**

```
enIDViewClientReturn  
SetDeviceStatusNotification(String DeviceList)
```

---

### ClearDeviceStatusNotification

**Description:**

The client calls this method to signal to IDViewClientWrapper to remove status notification on the device or devices listed. The client is able to specify multiple devices in this call.

**Method syntax:**

```
enIDSViewClientReturn
ClearDeviceStatusNotification(String DeviceList)
```

---

## GetDeviceStatus

**Description:**

A client can request status information on any group of devices to be sent immediately. This message, when received will result in `IDSViewClientWrapper` sending 1 or more `DeviceStatusNotification` events to the requesting client. In this scenario only the client that requested the information receives it and it is sent to the client via the direct socket link, not via the multicast facility.

**Method syntax:**

```
enIDSViewClientReturn GetDeviceStatus(String DeviceList)
```

---

## Device events

---

### OnDeviceStatusNotified

This message is sent to all interested parties, either directly or via the multicast mechanism when the status of a device changes. It is also sent as a response to the `GetDeviceStatus` method being received from a specific client.

Each message may contain 1 or more `DeviceStatus` sections that contain status information. Where a request is received for an unknown device then the status will contain the word "Unknown".

**Event syntax:**

```
OnDeviceStatusNotified(String AgentID,
String AgentName,
Int32 AgentState,
Int32 CallCount,
String Device,
String DeviceName,
Int32 FeatureState,
Int MessagingState,
String OSloggedInUserID,
String
```

**\* Note:**

FeatureState will be reserved for future use and will be set to 0 for all method calls. AgentState will follow the standard enumeration state.



## Real Time Reporting Data for Agents

IDSViewClientWrapper allows clients to notify interest in a specific agent ID Interaction Data Server - Voice and Presence holds information until the next polling period offers it to any clients that request information in the period between polling attempts.

---

## Agent methods

---

### SetRealtimeAgentNotification

**Description:**

The client calls this method to signal to IDSViewClientWrapper that it requires real-time notification of agent statistical data. Every period (for example, 5 seconds) IDSViewClientWrapper provides current real-time statistics. The client may send 1 or more agent IDs within the single request.

**Method syntax:**

```
enIDSViewClientReturn  
SetReal-timeAgentNotification(String AgentIDList)
```

---

### ClearRealtimeAgentNotification

**Description:**

The client calls this method to signal to IDSViewClientWrapper that it no longer requires real-time notification of statistics on 1 or more agents.

**Method syntax:**

```
enIDSViewClientReturn  
ClearReal-timeAgentNotification(String AgentIDList)
```

---

## Agent events

---

### OnRealtimeAgentStatusNotified

This message is sent to all interested parties, either directly or via the multicast mechanism when IDSViewClientWrapper gets an update of agent status.

Each message may contain 1 or more AgentStatus sections that contain status information. Where a request is received for an unknown device then the status will contain the word “Unknown”.

### Event syntax:

```
OnRealtimeAgentStatusNotified (String AgentID,
String AgentName,
Int32 AgentState,
Int32 AverageAfterCallWorkTime,
Int32 AverageAUXTime,
Int32 AverageAvailableTime,
Int32 AverageTalkTime,
Int32 CallsPerHour,
String Device,
Int32 PendingWorkMode,
Int32 ReasonCode,
String ServerInstanceID,
String ServerInstanceType,
String SplitSkill,
Int32 TalkState,
Int32 WorkMode)
```

---

## OnAgentLoggedIn

IDSViewClientWrapper sends this message to all connected clients when an agent logs in. This message will be forwarded immediately to all clients that have requested notification via the RealtimeAgentNotification method.

### Event syntax:

```
OnAgentLoggedIn (String AgentID,
String AgentName,
String Device,
String ServerInstanceID,
String ServerInstanceType,
String SplitSkill)
```

---

## OnAgentLoggedOut

IDSViewClientWrapper sends this message to all connected clients on agent log out.

### Event syntax:

```
OnAgentLoggedOut (String AgentID,
String AgentName,
String Device,
Int32 ReasonCode,
String ServerInstanceID,
String ServerInstanceType,
String SplitSkill)
```

---

## OnAgentStateChanged

IDSViewClientWrapper sends this message to all connected clients on an agent state changing.

### Event syntax:

```
OnAgentStateChanged (String AgentID,
String AgentName,
Int32 AgentState,
String Device,
Int32 MessagingState,
String OSLoggedInUserID,
Int32 PendingReasonCode,
Int32 PendingWorkMode,
Int32 ReasonCode,
String ServerInstanceID,
String ServerInstanceType,
String SplitSkill,
Int32 TalkState,
Int32 WorkMode)
```

## Real Time Reporting Data for VDN

IDSViewClientWrapper allows clients to notify interest in a specific VDN and sends reports periodically to clients.

IDSViewClientWrapper holds information until the next polling period and to send to any clients that request information in the period between polling attempts.

---

## VDN methods

---

### SetRealtimeVDNNotification

#### Descriptions:

The client calls this method to signal to IDSViewClientWrapper that it requires real-time notification of VDN statistical data. Every period (For example, 5 seconds) IDSViewClientWrapper returns current real-time statistics.

The client may send 1 or more VDNs within the single request.

#### Method syntax:

```
enIDSViewClientReturn
SetRealtimeVDNNotification(String VDNList)
```

---

## ClearRealtimeVDNNotification

### Descriptions:

Use this method to tell IDSViewClientWrapper to no longer provide real time notification of statistics on 1 or more VDNs.

### Method syntax:

```
enIDSViewClientReturn  
ClearRealtimeVDNNotification(String VDNList)
```

---

## VDN events

---

### OnRealtimeVDNStatusNotified

This message is sent periodically to all interested parties, either directly or via the multicast mechanism. This message will also be sent to all clients that request notification via the SetRealtimeVDNNotification method.

Each message may contain 1 or more VDNStatus sections that contain status information. Where a request is received for an unknown device then the status will contain the word "Unknown".

### Event syntax:

```
OnRealTimeVDNStatusNotified (Int32 AbandonCalls,  
Int32 AverageAbandonTime,  
Int32 AverageTalkTime,  
Int32 AverageWaitTime,  
Int32 CallsWaiting,  
Int32 LongestCall,  
String ServerInstanceID,  
String ServerInstanceType,  
String VDN,  
String VDNName)
```

### Real Time Reporting Data for Queue

IDSViewClientWrapper allows clients to notify interest in a specific queue and manages the periodic return of information to the client. IDSViewClientWrapper holds information until the next polling period to send to any clients that request information in the period between polling attempts.

---

## Queue methods

---

### SetRealtimeQueueNotification

**Description:**

The client calls this method of `IDSViewClientWrapper` to get real-time notification of queue statistical data. If the queue is a split skill device then every period (For example, 5 seconds) `IDSViewClientWrapper` returns realtime statistics. Initially the determination of whether this is a split/skill device will be based on whether the device is a numeric value. If the queue is a multimedia device then `IDSViewClientWrapper` will forward queue information.

The client may send 1 or more queue IDs within the single request.

**Method syntax:**

```
enIDSViewClientReturn  
SetRealtimeQueueNotification(String QueueList)
```

---

### ClearRealtimeQueueNotification

**Description:**

The client calls this method to signal to `IDSViewClientWrapper` that it no longer requires real-time notification of statistics on 1 or more queues.

**Method syntax:**

```
enIDSViewClientReturn  
ClearRealtimeVDNNnotification(String QueueList)
```

---

## Queue events

---

### OnRealtimeQueueStatusNotified

This message is sent periodically to all interested parties, either directly or via the multicast mechanism. It is also sent to all clients that request notification via the `SetRealtimeQueueNotification` message.

Each message may contain 1 or more `QueueStatus` sections that contain status information. Where a request is received for an unknown queue the status will contain the word "Unknown".

**Event syntax:**

```
OnRealtimeQueueStatusNotified (Int32 AgentsAvailable,
```

```
Int32 AgentsStaffed,  
Int32 AverageAbandonTime,  
Int32 AverageHandleTime,  
Int32 AverageWaitTime,  
Int32 InteractionsWaiting,  
Int32 OldestInteraction,  
String QueueID,  
String QueueName,  
String ServerInstanceFriendlyName  
String ServerInstanceID,  
String ServerInstanceType,  
Int32 TotalAbandonedInteractions,  
Int32 TotalInteractionsArrived,  
Int32 totalInteractionsArrivedLastHour ,  
Int32 TotalInteractionsArrivedThisHour,  
Int32 TotalInteractionsArrivedThisInterval,  
Int32 TotalInteractionsInProgress,  
Int32 TotalInteractionsSuspended,  
Int32 TotalInteractionsSuspendedThisInterval)
```

---

## Historical Reporting Data for Agent

---

### Agent Methods

These methods allow details of the agent's activity to be returned to the requester.

#### GetAgentHistory

This method returns the variable number of interactions that this agent has been a party to. The returned records list all the interaction sectors (a span from an interaction create through to close sequence) and the current state of each. The records include major Associated data (keyed to the conversation), the Server Instance ID and Type, the current interaction state and the associated agent ID (if any).

#### Message syntax:

```
[out] ReturnData  
GetAgentHistory(String AgentID, String MediaTypes, string InteractionStates, int DaysOld)
```

---

### Agent events

No events are defined at this time.

---

## Historical Reporting Data for Skill

---

### Skill methods

No methods are defined at this time.

---

### Skill events

No events are defined at this time.

---

---

## Historical Reporting Data for Queue

---

### Queue methods

No methods are defined at this time.

---

### Queue events

No events are defined at this time.

---

---

## Historical Reporting Data for Interaction

---

### Interaction methods

These methods allow details of an interaction to be returned to the client. The data the client receives is read-only; there is no facility to modify the data in the database.

### GetInteractionHistory

This method returns the variable number of state changes (segments) that have been recorded for all sectors of this Interaction to date.

### Method syntax:

```
[out] ReturnData  
GetInteractionHistory( String InteractionID, int DaysOld)
```

### Interaction events

No events are defined at this time.

---

## Conversation and Customer

---

### Conversation and Customer methods

These methods allow details of a conversation, including all interactions, to be returned to the client. The data the client receives is read-only; there is no facility to modify the data.

#### GetConversationHistory

This method returns the variable number of interaction sectors (a span from an interaction create through to close sequence) that belong to a single conversation. The data includes major Associated data (keyed to the conversation), the Server Instance ID and Type, the current interaction state and the associated agent ID (if any). This data is read only.

There is no facility to change this data.

#### Message syntax:

```
[out] ReturnData  
GetConversationHistory(  
String ConversationID,  
String CustomerID,  
int DaysOld)
```

### Conversation and Customer events

No events are defined at this time.

---

## Miscellaneous Capabilities

IDSViewClientWrapper offers the following capabilities that don't easily fall into the statistics/reporting paradigm.



---

## Miscellaneous capability methods

---

### SetClientIdentity

This method allows the client application connected to `IDSViewClientWrapper` to identify itself and some details about the user logged into the machine. This information can be updated at any time by the client to reflect changes in the client application. The values sent with this method will replace those values currently held by `IDSViewClientWrapper` for this client.

**Method syntax:**

```
enIDSViewClientReturn SetClientIdentity(String  
OSLoggedInUserID, String AgentID, String StationID)
```

Where,

- *OSLoggedInUserID* is the Windows user name that is currently logged into the client machine.
- *AgentID* is the agent ID (switch ACD) that is currently logged in at the client application.
- *StationID* is the station ID that is currently controlled by this client application.

---

### SetConversationIDForInteraction

This method allows the client application to specify the conversation id for a specific interaction. This linkage will allow multiple interactions to be grouped together to form a conversation.

**Method syntax:**

```
enIDSViewClientReturn  
SetConversationIDForInteraction(String InteractionID,  
String ConversationID)
```

---

### SetCustomerIDForInteraction

This method allows the interaction to be associated with a specific customer. This method can be called at the client once the client has correctly identified the customer. This could be via an automatic mechanism (For example, CLI lookup) or through manual searching. Linking interactions to customers allows extended information to be retained about an interaction and also allows the customer history through Call Center Elite Multichannel to be retained.

**Message syntax:**

```
enIDSViewClientReturn  
SetCustomerIDForInteraction(String InteractionID,  
String CustomerID)
```

---

## SetWorkCodeForInteraction

Adding work codes to an interaction allows extended information about the reason for a call and its disposition to be recorded. These work codes can then be used for reporting purposes.

### Message syntax:

```
enIDSViewClientReturn SetWorkCodeForInteraction(String
InteractionID, String AgentID, String WorkCodeTopic,
String WorkCodeKey, String WorkCodeValue)
```

## Miscellaneous capability events

No events are defined at this time.

---

## Enumerations

The following enumerations are defined for use in Interaction Data Server - View methods and events.

Name	Description	Value
<b>enIDSViewClientReturn</b>		
UnknownError	Unknown error encountered	0
NoError	The method executed correctly	1
NewClient	Registration of new client succeeded	2
AlreadyRegistered	Client has already been registered	3
NotRegistered	Client has not been registered	4
Succeed	The method call completed successfully.	5
PartiallySucceed	Function has partially succeeded	6
EmptyInput	No parameters were provided.	7
InvalidInput	A specified parameter is either invalid or missing.	8

---

## Reporting from AvayaCMS

Call Center Elite Multichannel makes some of the multimedia reporting data held within the Interaction Data Service easily available to the Avaya Call Management System (Avaya CMS) package.

To enable an Avaya CMS user to view information about multimedia work items currently held within Call Center Elite Multichannel media store queues, a plug-in named Multimedia CMS Plug-in extracts the data from Interaction Data Server - Multimedia and inserts it into a custom table in the CMS Informix database. This data is then displayed to the user via a custom report called CCEDData.rep.

On start up, Multimedia CMS Plug-in deletes (if it exists) all Call Center Elite Multichannel related data from the CMS database and recreates the table and statistical queue data. Table rows are automatically updated or added on receipt of events.

## Installing and Configuring Multimedia CMS Plug-in

### About this task

The Multimedia CMS Plug-in is installed and made available with the standard Interaction Data Server-Multimedia install.

### Procedure

1. After configuring the Multimedia CMS plug-in, you must also configure the ODBC driver that sends signal to the CMS Informix database. For more information about configuring the Multimedia CMS plug-in, see [\[IDS MMAE CMS Engine\]](#) on page 299.

#### \* Note:

If you are running Microsoft Windows 2008 64-bit Operating System or Microsoft Windows 2008 R2, you must run the Data Sources (ODBC) 32-bit application.

To run the 32-bit version Data Sources application:

- a. Click **Start > Run**.
  - b. In the Run window, type `C:\Windows\SysWOW64\odbcad32.exe` and press `Enter`.
2. Install the IBM Informix ODBC software on the system where Interaction Data Server is running.

### Related Links

[Configuring an ODBC data source](#)

[Installing ODBC on a Windows client](#)

## Installing ODBC on a Windows client

### Before you begin

Ensure that:

- You have installed the client network software on your computer.
- Your computer is communicating with the Avaya Call Management System (CMS) server over the network.

To ensure the communication between your computer and the CMS server, you can use the Packet Internet Groper (PING) utility on your desktop.

### Procedure

1. Download the IBM Informix Client SDK from IBM website:
  - [IBM Informix Client SDK for 32-bit operating system](#)
  - [IBM Informix Client SDK for 64-bit operating system](#)
2. Double-click the `Installclientsdk.exe` file.

3. On the Introduction screen, click **Next**.
4. On the Software License Agreement screen, click **I accept the terms in the license agreement** and click **Next**.
5. On the Installation Location screen, click **Next**.
6. **(Optional)** To install the IBM Informix ODBC driver software to a location other than the default location, click **Choose** and select a location.
7. On the Choose Client SDK Features to install screen, select the features that you want to install and click **Next**.
8. On the Webserver Configuration screen, click **Next**.
9. On the OAT Administrator login setup screen, perform the following steps:
  - a. In the **User name** field, enter a user name for accessing the OAT admin pages.
  - b. In the **Password** field, enter a password for accessing the OAT admin pages.
  - c. In the **Retype the password** field, reenter the password for accessing the OAT admin pages.
10. On the Installation Summary screen, click **Install**.
11. On the IBM Data Server Driver Package screen, select **No** and click **Next**.
12. On the Installation Complete screen, click **Done**.

## Configuring an ODBC data source

### Configuring a system DSN

#### About this task

Using this procedure, you can add and configure a system DSN.

#### Procedure

1. Click **Start > Control Panel > Administrative Tools > Data Sources (ODBC)**.

The system displays the ODBC Data Source Administrator dialog box.
2. Click the **System DSN** tab.
3. Click **Add**.

The system displays the Create New Data Source dialog box.
4. Select IBM INFORMIX ODBC DRIVER and click **Finish**.

The system displays the IBM Informix ODBC Driver Setup dialog box.
5. In the **Data Source Name** and **Description** fields, type `cms_net`.
6. Click the **Connection** tab and perform the following steps:
  - a. In the **Server Name** field, type `cms_net`.
  - b. In the **Host Name** field, enter the IP address of the CMS server.
  - c. In the **Service** field, enter the port number as 50000.

- d. In the **Protocol** field, click `olsoctcp`.
  - e. Keep the **Options** field blank.
  - f. In the **Database Name** field, click `cms`.
  - g. In the **User Id** field, enter the user name to log in to the CMS server.
  - h. In the **Password** field, enter the password to log in to the CMS server.
7. Click the **Environment** tab and perform the following steps:
    - a. In the **Client Locale** and **Database Locale** fields, type `en_US.UTF8`.
    - b. Keep the default values in the remaining fields.
  8. Click **OK**.

### **Configuring a file DSN**

#### **About this task**

Using this procedure, you can add and configure a file DSN.

#### **Procedure**

1. Click **Start > Control Panel > Administrative Tools > Data Sources (ODBC)**.

The system displays the ODBC Data Source Administrator dialog box.

2. Click the **File DSN** tab.
3. Click **Add**.

The system displays the Create New Data Source dialog box.

4. Select IBM INFORMIX ODBC DRIVER and click **Next**.
5. Enter the location of the file data source and click **Next**.
6. Click **Finish**.

The system displays the IBM Informix ODBC Driver Setup dialog box.

7. Click the **Connection** tab and perform the following steps:

- a. In the **Server Name** field, type `cms_net` or `cms_[hostname]`.

Where hostname is the actual host name of the CMS server. If you do not know the host name, you can use `cms_net`. However, you cannot connect to multiple CMS systems simultaneously by using `cms_net`, because the **Server Name** field requires a unique value across all DSNs.

- b. In the **Host Name** field, enter the IP address of the CMS server.
- c. In the **Service** field, enter the port number of your database host machine.

If you have entered `cms_net` in the **Server Name** field, then you must enter the port number as 50000. If you have entered `cms_[hostname]` in the **Server Name** field, then you must enter the port number as 50001.

- d. In the **Protocol** field, click `olsoctcp`.

- e. Keep the **Options** field blank.
  - f. In the **Database Name** field, click `cms`.
  - g. In the **User Id** field, enter the user name to log in to the CMS server.
  - h. In the **Password** field, enter the password to log in to the CMS server.
8. Click the **Environment** tab and perform the following steps:
    - a. In the **Client Locale** and **Database Locale** fields, type `en_US.UTF8`.
    - b. Select the **Use Server Database Locale** check box.
    - c. Keep the default values in the remaining fields.
  9. Click the **Connection** tab.
  10. Click **Apply & Test Connection**.

After successful configuration, the system displays the message `Test connection was successful`.

### **Configuring the Interaction Data Service Multimedia .ini file**

#### **About this task**

Using this procedure, you can configure the `ASIDSMultimedia ini` file.

#### **Procedure**

1. Open the Windows Services application.
  - a. Click **Start > Run**.
  - b. In the Run dialog box, type `services.msc`.
  - c. Click **OK**.
2. Stop the **AS Interaction Data Service - Multimedia** service.
3. Go to `C:\Program Files (x86)\Avaya\Avaya Aura CC Elite Multichannel\Server\Interaction Data Server - Multimedia`.
4. Double-click the `ASIDSMultimedia.ini` file.
5. In the **Error Logging** section, set the **Error Log Level** field to 1.
6. In the **IDS MMAE CMS Engine** section, perform the following steps:
  - a. In the **Database User Name** field, type the user name of the CMS account that you use to connect to the DSN.
  - b. In the **Database User Password** field, type the password of the CMS account that you use to connect to the DSN.
  - c. In the **Database Server Name** field, type the IP address of the CMS server.
  - d. In the **File DSN** field, type the path containing the .ini file.
7. Click **Save**.

8. Open the Windows Services application and start the **AS Interaction Data Service - Multimedia** service.
9. Go to `C:\Program Files (x86)\Avaya\Avaya Aura CC Elite Multichannel\Server\Interaction Data Server - Multimedia`.
10. Open the `[currentday]ASIDSMultiMedia.log` file.  
In this case, `[currentday]` specifies a day of the week. For example, `MonASIDSMultiMedia.log`.
11. In the log file, search for the word `CONNECTED` and verify the connection for each media store.

### **Verifying the ODBC database on a CMS server**

#### **Before you begin**

Ensure that you install PuTTY on the server.

#### **About this task**

Using this procedure, you can verify the ODBC database on a CMS server.

#### **Procedure**

1. Start PuTTY.
2. In the PuTTY Configuration dialog box, perform the following steps:
  - a. In the **Host Name (or IP address)** field, enter the IP address of the CMS server.
  - b. In the **Connection type** field, click **SSH**.
  - c. Click **Open**.
3. In the **login as** field, enter the user name of the CMS account that you use to connect to the DSN and press **Enter**.
4. In the **Password** field, enter the password of the CMS account that you use to connect to the DSN and press **Enter**.
5. Type `export INFORMIXSERVER=cms_ol` and press **Enter**.
6. Type `cd /opt/informix/bin` and press **Enter**.
7. Type `./dbaccess` and press **Enter**.
8. Select **Table** and press **Enter**.
9. Select the **cms@cms\_ol** database and press **Enter**.
10. Select **Info** and press **Enter**.
11. Select **c\_cceqd** and press **Enter**.
12. Select **Columns** and press **Enter**.

The DISPLAY menu shows the table and the table structure.

### Loading a CMS report to CMS Supervisor Procedure

1. In the Call Center Elite Multichannel Installation DVD, navigate to the CMS report present in the `\Avaya Aura CC Elite Multichannel\Server\Interaction Data Server\CMS Report` folder.
2. Load the CMS report to CMS Supervisor using CMS Supervisor Client.

### CCE Queue Data

root_cmstbls							
tabname	colname	l_colname	syn_type	disp_type	csa_type	tabtype	description
c_cceqd	ACD	acd	acd	number	N	h	ACD number associated with the row of data.
c_cceqd	AGENTSAVAILABLE	agentsavailable	no_syn	umber	N	h	The number of agents available in this queue. NOT USED
c_cceqd	AGENTSSTAFFED	agentsstaffed	no_syn	number	N	h	The number of agents staffed in this queue. NOT USED
c_cceqd	AVGABNTIME	avgabntime	no_syn	duration	N	h	The average time an interaction waited before it was abandoned.
c_cceqd	AVGHANDLETIME	avghandletime	no_syn	duration	N	h	The average time an interaction takes to be completed.
c_cceqd	AVGWAITTIME	avgwaittime	no_syn	duration	N	h	The average time an interaction waits for service in this queue. This time does not include time an interaction is suspended.
c_cceqd	INTWAITING	intwaiting	no_syn	number	N	h	The number of interactions waiting to be processed by this queue. This

*Table continues...*



root_cmstbls							
tabname	colname	l_colname	syn_type	disp_type	csa_type	tabtype	description
							value does not include interactions in progress or suspended.
c_cceqd	LASTUPDATETIME	lastupdatetime	no_syn	date	N	h	The time the row was last updated.
c_cceqd	OLDESTINT	oldestint	no_syn	duration	N	h	How long the oldest interaction has been waiting for service. This will not include interactions that have been delivered to agents and then suspended for future processing.
c_cceqd	OWNERSID	ownersid	no_syn	text	N	h	The server instance ID of the Multimedia CMS Plug-in that generated data for this row.
c_cceqd	QUEUEID	queueid	no_syn	text	N	h	The identifier of the queue this information represents.
c_cceqd	UEUENAME	queuename	no_syn	text	N	h	The queue name, eg email address, SMS number.
c_cceqd	SID	sid	no_syn	text	N	h	The server instance ID of the media store that generated this row of queue information.
c_cceqd	SIDFRIENDLYNAME	sidfriendlyname	no_syn	text	N	h	The friendly (display) name for the server

*Table continues...*

root_cmstbls							
tabname	colname	l_colname	syn_type	disp_type	csa_type	tabtype	description
							that generated this row of queue information.
c_cceqd	SIT	sit	no_syn	text	N	h	The server instance type of the server that generated this row of queue information.
c_cceqd	TOTABNINT	totabnint	no_syn	number	N	h	The number of interactions that have been abandoned before being delivered to an agent for processing. This figure will only be valid for session-based interactions (eg, web chat, MSN Messenger).
c_cceqd	TOTINTARRIVED	totintarrived	no_syn	number	N	h	The total number of interactions received.
c_cceqd	TOTINTINPROGRESS	totintinprogress	no_syn	number	N	h	The total number of interactions that have been delivered to agents for processing. This count will include interactions that have yet to be accepted by the agent.
c_cceqd	TOTINTINTERVAL	totintinterval	no_syn	number	N	h	The total number of interactions received this interval.
c_cceqd	TOTINTLASTHOUR	totintlasthour	no_syn	number	N	h	The total number of interactions that were

*Table continues...*

root_cmstbls							
tabname	colname	l_colname	syn_type	disp_type	csa_type	tabtype	description
							received in the last hour.
c_cceqd	TOTINTSUSPENDED	totintsuspended	no_syn	number	N	h	The total number of interactions that are currently suspended for this queue.
c_cceqd	TOTINTSUSTHISINTV	totintsusthisintv	no_syn	number	N	h	The total number of interactions suspended this interval.
c_cceqd	TOTINTTHISHOUR	totintthishour	no_syn	number	N	h	The total number of new interactions that have been received this hour.

## Adding Designer in CMS Supervisor

### About this task

Using this procedure, you can add Designer in CMS Supervisor

### Procedure

1. Open Avaya CMS Supervisor.
2. In the main menu bar, click **Commands > Report Wizard**.
3. On the General Information screen, click **Next**.
4. On the Select a Report Type screen, select **Daily** in the Historical section and click **Next**.
5. On the Select a Report Layout screen, click the report layout with a single table, and then click **Next**.
6. On the Select a Data Group screen, select the data group for the report and click **Next**.
7. On the Select Data Items screen, click **Next**.
8. On the Select Table Format screen, select **Fill Table by Row** and click **Next**.
9. On the Change Input Captions screen, click **Next**.
10. On the Preview Option screen, click **Next**.
11. On the Save Report screen, perform the following steps:
  - a. In the **Report Name** field, enter a name for your report.
  - b. In the **Report Description** field, enter a description for your report.

- c. In the **Report Available To** field, select **Everyone** or **Only Me**.
  - d. Click **Next**.
12. On the Finish screen, perform the following steps:
  - a. In the **Run report for ACD** field, click the ACD for your report.
  - b. In the **Finish Button Options** field, select **Run Report**.
  - c. Click **Finished**.
13. On the **Report Wizard** dialog box, click **Cancel**.

## Result

When you open CMS Supervisor and click **Commands > Reports**, you can see Designer in the **Category** field.

## Running the CCE Queue Data report

### About this task

On the Call Center Elite Multichannel DVD or in the installation directory of Call Center Elite Multichannel, you can find the `CCE Queue Data.rep` report file in the `\Avaya Aura CC Elite Multichannel\Server\Interaction Data Server\CMS Report` directory. This report is similar to the VDN real-time report available in the base CMS package.

To use this report, you must copy the report to the directory on the CMS system that contains CMS reports.

### Procedure

1. Open Avaya CMS Supervisor.
2. From the main menu bar, click **Commands > Reports**.

The system displays the Select a Report dialog box.
3. Click the **Historical** tab.
4. In the **Category** field, click **Designer**.
5. Click **Copy**.

The system displays the Copy Report dialog box.
6. Select the **From a PC File to the CMS Server** option.
7. Click **OK**.
8. In the Avaya Aura® Call Center Elite Multichannel application DVD or installation location, go to the `\Avaya Aura CC Elite Multichannel\Server\Interaction Data Server\CMS Report` directory and double-click the `CCE Queue Data.rep` file.

The system displays a message confirming that the report is loaded successfully.
9. In the **Report** field, double-click **CCE QueueData** to run the report.

The system displays the CCE Queue Data report.

# Chapter 15: Troubleshooting

---

## Troubleshooting Communication Manager Admin

---

### Cannot establish the SSH connection to Communication Manager

**Problem:** Cannot establish the SSH connection to Communication Manager from Call Center Elite Multichannel due to network failure or wrong settings for the host, port, user name, password, or pin.

The system displays the following error message: *Failed to connect to Communication Manager.*

#### Proposed Solution

##### Procedure

1. If the remote host does not connect due to network failure or wrong host or port settings, the following message appears:

```
[Mon Nov 16 10:53:10.784],Fatal,7540,Avaya Aura® CM Administration: Exception caught trying to send command <list agent-loginID >. Exception text: System.Net.Sockets.SocketException: A connection attempt failed because the connected party did not properly respond after a period of time, or established connection failed because connected host has failed to respond 135.124.108.50:5022
```

2. If the user name or password is incorrect, the following message appears:

```
[Mon Nov 16 10:55:18.893],Fatal,5592,Avaya Aura® CM Administration: Exception caught trying to send command <list agent-loginID >. Exception text: Auth fail.
```

You can collect more details in the log file by setting the error log level to 1 in the Control Panel configuration.

#### Proposed Solution

##### About this task

Refer the log file of the `ASGUIHost` system.

## Procedure

1. If the log file contains log information related to network failure:
  - Check if the Communication Manager server is properly connected.
  - Check if you have specified the correct IP address and port number for the Communication Manager connection.
2. If the log file contains log information related to incorrect user name or password:
  - Check if you have specified correct user name and password to connect the Communication Manager server.

## Communication Manager displays an error message when saving the data

**Problem:** When you try to save the data while you are configuring Communication Manager, the error message appears in the following format:

**<error message> (field name; index)**

Where,

### **Proposed Solution**

#### **Procedure**

1. **<error message>** is the message that appears from Communication Manager.
2. **field name** is the name of the field that has the incorrect setting.
3. **index** is the line number of the field, if there are multiple lines for any field. Index is always 0 if it is a simple field.

For example:

If a skill is configured for an agent and you forget to set the Skill Level (SL), the following error message appears:

**Field cannot be blank (SL; 4)**

This error indicates that you have not assigned SL to the skill with index 4 in the **Assigned Skills** list box.

### **Proposed Solution**

#### **About this task**

Reset the SL and try again.

# Appendix A: Log files in Call Center Elite Multichannel

Call Center Elite Multichannel logs error information for each configured service in different log files. The system stores the logging information, using the Avaya Common Logging format. The following is an example of a sample log message for License Director:

```
Apr 10 10:11:06 pucedev92 ASLicenseDirector.exe[1888]: +05:30 2010 400 1 .cce
| 0 Status [2732] [T 23] A new client (Key =
7ee6e053-86f2-4484-8921-3ce21e06572a) has connected to the server from
148.147.170.92:2910. Total clients connected = 2
```

When you configure a service, you can select one or both the following options to enable the system to log the information in a log file:

- **Classic Logging.** In this traditional logging process, Call Center Elite Multichannel creates a log file for each service in the respective folder of that service. This increases the time to search a log file for a particular service and diagnose the trouble.
- **TTrace Logging.** In this new logging process, the system creates log files on a central server called TTrace server. From the TTrace server, you can view and configure the log details in TTrace console.

TTrace server and TTrace console are the components of the Trace system that you can install from the Call Center Elite Multichannel installer.

For more information, see *Avaya Aura® Call Center Elite Multichannel TTrace Console User Guide*.

---

## Classic Logging

In Classic Logging, Call Center Elite Multichannel logs the operation information of each configured service in a separate log file. A new log file is created every day.

The name of the error log file clearly identifies the application and the day of the week, for example, **MonASGUIHost.log**, where, **Mon** is the day of the week when the system creates a log file and **ASGUIHost** is the application extension for which the system creates a log file

After the file size reaches the limit specified in the configuration, the system archives the log file in the same directory of the log file and creates a new log file.

**\* Note:**

If a log file reaches the size limit on the same day that the system creates the file, the system creates the log file copy, in addition to archiving the file. The `.old` extension is added to the existing extension of the copy of log file.

The system stores only one log file in an archive. If a second log file reaches the specified maximum size, the system overwrites the archived log file.

The errors and information that the system logs in a log file is determined by the logging level defined in the `.ini` file of the corresponding service in Call Center Elite Multichannel. For more information about logging levels, see [Logging levels](#) on page 336.

In each log file, the system records the selected logging level, date, time, location, and description of every error based on the logging level that you select.

The system saves each error log file in the current working directory of the corresponding service in Call Center Elite Multichannel.

Call Center Elite Multichannel enhances Classic Logging to make the logging compliant with the Avaya Common Logging format. The log message includes the following fields:

- **Hostname**
- **UTC (Universal Time Coordinated) Offset**
- **Process Name (TAG) and [Process ID]**
- **Log Format**
- **Product Type**
- **Marker Field**

---

## Logging levels

A logging level defines the errors or information that the system logs in a log file.

The following are the error logging levels:

- 0. No error logging takes place
- 1. Logs fatal, major, minor errors, and trace information
- 2. Logs fatal, major, and minor errors
- 4. Logs fatal and major errors
- 8. Logs only fatal errors



---

## Custom log level for diagnostic testing

You can use a custom log level to create log files that do not overwrite each other, every time the maximum file size limit is reached. To create this logging level, add 128 to one of the default logging levels and set that value to the **Error Log Level** parameter in the configuration file.

### Caution:

To prevent creating multiple log files that consume disk space, use this error log level only when you perform diagnostic testing.

For example, in the configuration file, if you specify Error Log Level=129 (1+128), the new error log files that are created contain information related to fatal, major, minor, and trace errors.

Each new log file name is unique, based on the year, date, month, day, hours, minutes, and seconds format.

For example, in the log file name **YYYYMMDDHHMMSSASMediaDirector.log**:

YYYY = Year	MM = Month	DD = Day
HH = Hour	MM = Minute	SS = Second

---

## TTrace Logging

In TTrace Logging, the system creates log files on a central server from where you can open these log files and view the details. The information and errors that the system stores in a log file depends on the logging level that you set in the TTrace console.

You can use TTrace logging only after you install the TTrace system from the Call Center Elite Multichannel installation package. The TTrace system consists of the following components:

- TTrace server
- TTrace console
- TTrace config
- TTrace Log2Zip

You can use these components to perform the TTrace logging functions.

---

## TTrace server

The TTrace server acts as a central server to store log files of all services.

For each service that you configure in Call Center Elite Multichannel, the system creates a separate log file on the TTrace server and adds the logging information to the corresponding log file. Each

new log file name is unique, based on the date in year, month, and day format, and the name of the service for which the system creates a log.

Following is the syntax in which the system creates a log file name.

```
<YYYY>_<MM>_<DD>_tt_<service_name@server_name>.<file_extension>
```

For example, 2010\_04\_19\_tt\_[ASLicenseDirector@puccdev92].log.

**\* Note:**

When installing the TTrace system, you must specify the IP address of the TTrace server and the port number to access the TTrace server. The default port number is 10400.

---

## TTrace console

The **TTrace console** is a tool to view the logged information for each service that you configure.

The User Interface (UI) of the TTrace console contains a left pane and a right pane.

In the left pane, the system displays a list of services that you configure and that are running. In the same pane, you can also select logging levels.

In the right pane, the system displays the logged messages for a service that you select in the left pane.

For more information, see *Avaya Aura® Call Center Elite Multichannel TTrace Console User Guide*.

---

## TTrace config

You can use the **TTrace config** tool to configure TTrace logging. For more information about the TTrace Config tool, see *Installing Avaya Aura® Call Center Elite Multichannel*.

In this tool, you can update the **Directory for logfiles** field by specifying a directory on the TTrace server. The system saves the TTrace log file in the specified directory.

You can also use **TTrace config** to configure the TTrace system to send an email to a configured email ID, when the system logs a particular type of alarm on the TTrace server.

For more information about configuring the email and logscan for TTrace, see *Avaya Aura® Call Center Elite Multichannel TTrace Console User Guide*.

**\* Note:**

You can also use the default configuration file `tt_srv_cce.xml` to understand the settings and modify the values as per your requirements. This .XML file is provided with the TTrace installation.

---

## TTrace Log2Zip

Log2Zip is an archiving tool in the TTrace system that archives log files from the TTrace server. For archiving, specify the start date and end date to archive log files created between the selected start date and end date.

You can select particular services to enable the system to archive the log files only for select services. For creating the archives of log files see *Avaya Aura® Call Center Elite Multichannel TTrace Console User Guide*

 **Note:**

To archive the log files, you must manually run the Log2Zip tool.

---

## Error Logging

The configuration file for each service stores the default error logging information. When you select any service in Call Center Elite Multichannel Control Panel, the system reads the configuration file of the respective service. The system then displays the error logging options, such as level, size, and file name, according to the values specified in the configuration file.

 **Important:**

Configure error logging options only when you want to change the default values.

---

## Configuring error logging

### Procedure

1. Open **Control Panel**.
2. Expand the service node for which you want to set the Error Logging.
3. Right-click the specific service node and click **Edit**.
4. Enter the appropriate values in the **Error Logging** section.
5. Right-click the respective tab and select **Save And Close** to save the information.

The system updates the respective configuration file with the updated values of logging options.

### Related Links

[Error Logging field descriptions](#) on page 340

## Error Logging field descriptions

Name	Description
<b>Level</b>	<p>The logging level defines the errors or information that the system logs in a log file.</p> <p>The following are the error logging levels:</p> <ul style="list-style-type: none"> <li>• 0. No error logging takes place</li> <li>• 1. Logs fatal, major, minor errors, and trace information</li> <li>• 2. Logs fatal, major, and minor errors</li> <li>• 4. Logs fatal and major errors</li> <li>• 8. Logs only fatal errors</li> </ul>
<b>Classic Logging</b>	
<b>Classic Logging check box</b>	This option enables the system to create log files in a working directory of the selected service.
<b>Path</b>	The path to store the log file. By default, the system stores a log file to the working directory of Call Center Elite Multichannel Control Panel.
<b>Size</b>	<p>The maximum size for a log file, in Kilo Bytes (KB).</p> <p>After the maximum limit, the system archives the log file and creates a new log file.</p>
<b>Extension</b>	The extension of a log file.
<b>TTrace Logging</b>	
<b>TTrace Logging check box</b>	This enables the system to create log files on a TTrace server that you configured.
<b>TTrace Host</b>	The TTrace server address where the system creates the log files.
<b>Port No</b>	<p>The port number to access the TTrace server.</p> <p>Default is 10400 and maximum limit is 65535.</p> <p> <b>Important:</b></p> <p>If you enter a value in the <b>Port No</b> field that is beyond the maximum limit, the system displays an error message and resets the <b>Port No</b> field to a valid port number, which is within the supported limit.</p>

# Appendix B: Alarms and notifications

The services that are configured in Call Center Elite Multichannel generate alarms and notifications. When a service generates an alarm or notification, Application Management Director (AMD) collects and logs the alarm or notification on TTrace Server. AMD also sends the same alarm or notification to Call Center Elite Multichannel Control Panel.

For more information, see [Log files in Call Center Elite Multichannel](#) on page 335.

In Call Center Elite Multichannel Control Panel, the **Alarms and Notifications** node displays all alarms and notifications. This node contains **Alarms** and **Notifications** as two separate nodes for displaying alarms and notifications separately.

## Important:

You cannot configure the **Alarms and Notifications** node in Call Center Elite Multichannel Control Panel. The system generates only predefined alarms and notifications.

When you click an alarm or notification, the text field at the bottom of the right pane displays information about the selected alarm or notification. The information helps you to investigate and resolve a problem.

The information for a notification includes the description of the notification. The information for an alarm includes the description of the alarm, resolution for the alarm, and additional data. The additional data can be the IP address and port of the server on which the corresponding service is configured. The additional data also contains the predefined variables. The system updates these variables in real time to display the current information about a service for which the alarm is sent.

For example, the additional data for the XML Link Down alarm for Media Director includes the Last Attempt Date/Time and Retry Count variables. The system updates the variables until the alarm exists.

---

## Alarms

To view all active and resolved alarms, you can click the **Alarms** node in Call Center Elite Multichannel Control Panel. The **Alarms** node contains the following sub-nodes:

- **Active.** The **Active** node displays a list of alarms that are generated when an abnormal condition occurs in any service running in Call Center Elite Multichannel. The status of alarms in this node is always Active.

The name of the **Active** node contains information about the number of active alarms against the total number of alarms.

Each alarm provides information that you can use to investigate the abnormal condition and resolve the problem.

An active alarm displays the following information:

- **Alarm Event Name.** The name of the event that generates the alarm.
- **Alarm Created Date Time.** The date and time when the alarm is generated.
- **Alarm Level.** The severity level of the alarm. The predefined severity levels are Fatal, Major, Minor, and Information.
- **Alarm State.** The state of the alarm. The default state is Active.
- **Alert State.** The alert state of the alarm. The alert state indicates whether the alarm is active. For information about changing the alert state, see [Changing alert state of an alarm](#) on page 342.
- **Activity Date Time.** The date and time when the system changes the details of the alarm.
- **Server Instance Name.** The name of the server that generates the alarm. When you right-click an alarm in the list and click **Select Application**, the system displays the Summary window of the service that generates the alarm.
- **Resolved.** The **Resolved** node displays the alarms that the system or you resolve. After an alarm is resolved, the system removes the alarm from the **Active** node and displays it in the **Resolved** node.

The name of the **Resolved** node contains information about the total number of alarms that the system resolves.

 **Note:**

You cannot delete alarms or notifications from the nodes. The system automatically removes the alarms and notification when the maximum limit reaches.

---

## Changing alert state of an alarm

### Procedure

1. In the **Alarms** node, click the **Active** node
2. In the right pane, click the alarm for which you want to change the alert state.
3. Perform one of the following actions:
  - To change the alert state to alerted, right-click the selected alarm and click **Set alert state to> Alerted**.
  - To change the alert state to acknowledged, right-click the selected alarm and click **Set alert state to> Acknowledged**.

---

## Notifications

Notifications indicate the change in state. For example, service started or service stopped.

 **Note:**

The change in state does not require immediate resolution.

Each notification includes information about the server whose state is changed.

A notification displays the following information:

- **Notification Name.** The name of the notification.
- **Notification Created Date Time.** The date and time when the notification is generated.
- **Server Instance Name.** The name of the server that generates the notification. When you right-click a notification and click **Select Application**, the system displays the summary of the service that generates the notification.

When you click a notification, the text field at the bottom of the right pane displays the description of the selected notification.

---

## License Director alarms

---

### WebLM connection error alarm

The system raises this alarm when a problem occurs in communication between License Director and the WebLM server.

This problem occurs if the WebLM URL is incorrect, the WebLM server is inoperative, or the WebLM server does not have a license file or the license file is expired. The system clears this alarm after the problem is resolved.

#### Severity

Major

#### Alarm description

The current WebLM URL is invalid, the WebLM service is inoperative, or the WebLM server has an incorrect license file.

#### Additional data

- License Type
- WebLM URL
- Connection Error Reason

## Resolving WebLM connection error alarm

### Procedure

1. Check if the WebLM service has the correct license file
2. Check if License Director connects with the WebLM server

## License expired alarm

The system raises this alarm when the WebLM license file expires. This alarm exists until you install a new license file with the correct expiry date.

### Severity

Major

### Alarm description

The current license has expired.

### Additional data

- Application Name
- License Type
- Expiration Date/Time

## Resolving License expired alarm

### Procedure

Obtain and install a new license of the same type on the WebLM server.

## License exhausted alarm

The system raises this alarm when the number of free licenses for a license key reaches to zero. This alarm exists until the number of free licenses rises above zero.

If applications continue to request licenses while the count remains at zero, the Client failure count increments. The system clears this count only when the application license is acquired successfully. For example, some licenses of the same type are released or a new license file with more capacity is installed on the WebLM server.

### Severity

Minor

### Alarm description

The maximum number of licenses for this application is issued.

### Additional data

- Application Name
- License Type
- License Size



## Resolving License exhausted alarm Procedure

Purchase additional licenses of the same type.

---

# License Director notifications

---

## Service started

The system generates this notification when the service for an application starts.

---

## Service stopped

The system generates this notification when the service for an application stops.

---

# Media Director alarms

---

## XML Link Down alarm

The system generates this alarm when Media Director cannot connect to the XML server that you have configured.

When Media Director fails to connect to the XML server on consecutive attempts, the system updates the following variables in the **Additional data** section of the alarm details:

- **Last Attempt Date/Time** . The last date and time when Media Director tried to connect with the XML server.
- **Retry Count** . The number of times Media Director tried to contact the XML server.

### Severity

Major

### Alarm description

The link to the XML server cannot be established. No work items can be processed while this link remains down.

### **Additional data**

- XML Server Link Name
- Last Link Error
- Last Attempt Date/Time
- Retry Count

## **Resolving XML Link Down alarm**

### **Procedure**

1. Check the configuration of the XML server and ensure that the service for the XML server is running.
2. Resolve the alarms for the XML server.

## **License Director Link Down alarm**

The system generates this alarm when Media Director cannot connect to License Director.

### **Severity**

Major

### **Alarm description**

The connection to License Director has failed and cannot be reestablished.

### **Additional data**

- License Director IP Address
- License Director Port
- Last Attempt Date/Time
- Retry Count

## **Resolving License Director Link Down alarm**

### **Procedure**

1. Resolve the pending alarms for License Director.
2. Check the configuration of License Director.  
For more information, see [Configuring License Director](#) on page 100.
3. On the **Summary** tab of License Director, check the **Service status** field to determine whether License Director service is running.

## **No Free Licenses alarm**

The system generates this alarm when the system denies an agent who is trying to connect to Media Director because License Director does not have free licenses.

The system keeps this alarm until another agent successfully connects to Media Director.

**\* Note:**

The system does not generate this alarm if Media Director cannot connect to License Director.

When an agent fails to connect to Media Director on consecutive attempts when this alarm exists, the system increments the value in the **Client failure count** variable. In addition, the system updates the **Last occurred date/time** variable in the **Additional data** section of the alarm details.

**Severity**

Minor

**Alarm description**

Client connections are rejected because of no free licenses on the administered License Director.

**Additional data**

- Last Attempt Date/Time
- Client Failure Count

**Resolving No Free Licenses alarm**

**Procedure**

Verify if the WebLM server contains enough licenses for the required features.

**Device Monitor Failure alarm**

The system generates this alarm when Media Director fails to monitor a device, such as VDN specified in the configuration of IDS server and VMS. The system generates a separate alarm for each VDN that Media Director fails to monitor.

This alarm for each VDN exists until:

- Media Director successfully monitors that VDN.
- You remove that VDN from the configuration of VMS using Call Center Elite Multichannel Control Panel.
- Media Director cannot connect to the XML server.

**\* Note:**

The system does not generate this alarm if Media Director cannot connect the XML server.

When Media Director fails to monitor a specified device on consecutive attempts, the system updates the **Last attempt** and **Retry Count** variables in the **Additional data** section of the alarm details.

**Severity**

Minor

**Alarm description**

The attempt to monitor the specified device failed.

**Additional data**

- Device
- Last Error Code

- Last Attempt Date/Time
- Retry Count

### **Resolving Device Monitor Failure alarm**

#### **Procedure**

1. Check if you have specified the correct device.
2. Check if the device exists in Communication Manager.
3. Check if you have added the device in the Application Enablement Service security database.

### **Make Call Failure alarm**

The system generates this alarm when a device that you specify in the configuration of IDS server and VMS fails to originate the first call. This alarm exists until that VDN successfully originates the first call.

After failure in originating the first call, if the VDN fails to originate a call on consecutive attempts, the system updates the alarm details in Application Management Director (AMD). Also, the system updates the **Last Attempt Date/Time** and **Failure Count** variables in the **Additional data** section of the alarm details for each consecutive failure.

The system generates an alarm for each VDN that fails to originate a call.

#### **Severity**

Minor

#### **Alarm description**

An attempt to make a call from the specified device failed.

#### **Additional data**

- Make Call Device
- Destination
- Last Error Code
- Last Attempt Date/Time
- Failure Count

### **Resolving Make Call Failure alarm**

#### **Procedure**

Check the configuration of Media Director and Communication Manager.

---

## Media Director notifications

---

### NotificationServiceStarted

The system generates this notification when the service for an application starts.

---

### NotificationServiceStopping

The system generates this notification when the service for an application is about to stop.

---

### Queue Added

The system generates this alert notification when you add a new queue to Media Director using Control Panel interface.

#### Additional data

- Media Director Queue Name

---

### Queue Removed

The system generates this alert notification when you remove a queue from Media Director using Control Panel interface.

#### Additional data

- Media Director Queue Name

---

## Email Media Store alarms

---

### AlarmMediaDirectorLinkDown

The system generates this alarm when Email Media Store cannot connect to Media Director.

#### Severity

Major

#### Additional data

- Media Director URL

- Media Director Name

## Resolving AlarmMediaDirectorLinkDown

### Procedure

1. Resolve the pending alarms for Media Director.
2. Check the configuration of Media Director.

For more information, see [Configuring Media Director](#) on page 103.

3. Verify if the service for Media Director is running.

## AlarmDatabaseConnectionDown

The system generates this alarm when Email Media Store cannot connect with a database that you have configured for Media Store.

The system resolves this alarm only when EMS successfully connects with the database configured for Media Store.

### Note:

Even after this alarm is cleared, the system does not automatically move this alarm in the **Resolve** node. You must perform another action on the database to move that alarm in the **Resolve** node.

### Severity

Major

### Additional data

Database Server Name

## Resolving AlarmDatabaseConnectionDown

### Procedure

1. Check the configuration of databases for Contact and Media Store in Email Media Store.
2. Test the database connection using Call Center Elite Multichannel Control Panel.

## AlarmSMTPServerDown

The system generates this alarm when EMS cannot communicate with the Simple Mail Transfer Protocol (SMTP) server.

### Severity

Major

### Additional data

SMTP Server Name.

## Resolving AlarmSMTPServerDown

### Procedure

Check the configuration of the SMTP server and the corresponding email addresses.

## AlarmPop3ServerDown

The system generates this alarm when EMS cannot communicate with the Post Office Protocol 3 (POP3) server.

### Severity

Major

### Additional data

POP3 Server Name

## Resolving AlarmPop3ServerDown

### Procedure

1. Check the configuration of the POP3 server.
2. Check the user name and password for the POP3 mailbox.

---

## Email Media Store notifications

---

### NotificationServiceStarted

The system generates this notification when the service for an application starts.

---

### NotificationServiceStopping

The system generates this notification when the service for an application is about to stop.

---

### NotificationQueueAdded

The system generates this alert notification when you add a new queue to EMS using Control Panel interface.

### Additional data

- Queue ID
- Queue Name

## NotificationQueueRemoved

The system generates this alert notification when you remove a queue from EMS using Control Panel interface.

### Additional data

- Queue ID
- Queue Name

---

## Preview Contact Media Store alarms

---

### AlarmMediaDirectorLinkDown

The system generates this alarm when Preview Contact Media Store cannot connect with Media Director.

The system resolves this alarm only when Preview Contact Media Store successfully connects with Media Director.

When Preview Contact Media Store fails to connect with Media Director on consecutive attempts, the system updates the **Last Attempt Date/Time** and **Retry Count** variables in the Additional data section of the alarm details.

### Severity

Major

### Alarm description

The link to the configured Media Director cannot be established. No work items can be processed while this link remains down.

### Additional data

- Media Director Name
- Media Director URL
- Last Connection Date/Time
- Last Attempt Date/Time
- Retry Count

### Resolving AlarmMediaDirectorLinkDown

#### Procedure

1. Resolve the pending alarms for Media Director.
2. Check the configuration of Media Director.



For more information, see [Configuring Media Director](#) on page 103.

3. Verify if the service for Media Director is running.

## AlarmDatabaseConnectionDown

The system generates this alarm when Preview Contact Media Store performs a database activity, but cannot connect with the Media Store database. You can verify this database activity from the log files of Preview Contact Media Store.

The system resolves this alarm only when Preview Contact Media Store successfully connects with the database configured for Media Store.

### **Note:**

Even after this alarm is cleared, the system does not automatically move this alarm in the **Resolve** node. You must perform another successful action on the database to move that alarm in the **Resolve** node.

### **Severity**

Major

### **Alarm description**

The Media Store cannot connect to the ASMediaStore database. No interactions can be processed while this connection remains down.

### **Additional data**

- Database Server name
- Last Attempt Date/Time
- Retry Count

## **Resolving AlarmDatabaseConnectionDown**

### **Procedure**

1. Verify if you have specified the correct value of the connection.
2. Verify if the service for SQL is running on the specified system.

---

# Preview Contact Media Store notifications

---

## NotificationServiceStarted

The system generates this notification when the service for an application starts.

## NotificationServiceStopping

The system generates this notification when the service for an application is about to stop.

---

## NotificationProgramStarted

The system generates this notification when a program in Media Store starts. Before starting, the program can be in stopped mode.

### Additional data

- Program ID
  - Program Name
  - Schedule ID
  - Schedule Name
  - Schedule Resume Type
  - Queue Name
  - Current Work Item Count - work to do
- 

## NotificationProgramStopped

The system generates this notification when a program in Media Store stops. Before stopping, the program can be in running mode.

### Additional data

- Program ID
  - Program Name
  - Schedule ID
  - Schedule Name
  - Queue Name
  - Processed Work Item Count - work done
  - Current Work Item Count - work left to do
- 

## NotificationProgramScheduleChanged

The system generates this notification when you change the schedule for a program that is running.

### Additional data

- Program ID

- Program Name
- Old Schedule ID
- Old Schedule Name
- New Schedule ID
- New Schedule Name
- Queue Name

---

## Simple Messaging Media Store alarms

---

### AlarmMediaDirectorLinkDown

The system generates this alarm when Simple Messaging Media Store cannot connect with Media Director.

#### Severity

Major

#### Additional data

- Media Director URL
- Media Director Name

### Resolving AlarmMediaDirectorLinkDown

#### Procedure

1. Resolve the pending alarms for Media Director.
2. Check the configuration of Media Director.  
For more information, see [Configuring Media Director](#) on page 103.
3. Verify if the service for Media Director is running.

### AlarmDatabaseConnectionDown

The system generates this alarm when Simple Messaging Media Store cannot connect with a database that you have configured for Media Store.

The system resolves this alarm only when Simple Messaging Media Store successfully connects with the database configured for Media Store.

#### Note:

Even after this alarm is cleared, the system does not automatically move this alarm in the **Resolve** node. You must perform another successful action on the database to move that alarm in the **Resolve** node.

### **Severity**

Major

### **Additional data**

- Database Server Name

## **Resolving AlarmDatabaseConnectionDown**

### **Procedure**

1. In the configuration of Simple Messaging Media Store, check the configuration of the Media Store database.
2. Test the connection to the Media Store database.

---

## **Simple Messaging Media Store notifications**

---

### **NotificationServiceStarted**

The system generates this notification when the service for an application starts.

---

### **NotificationServiceStopping**

The system generates this notification when the service for an application is about to stop.

---

### **NotificationQueueAdded**

The system generates this notification when you add a new queue to Simple Messaging Media Store using Control Panel interface.

#### **Additional data**

- Queue ID
- Queue Name

---

### **NotificationQueueRemoved**

The system generates this notification when you remove a queue from Simple Messaging Media Store using Control Panel interface.

#### **Additional data**

- Queue ID

- Queue Name

---

## AOL Messenger Gateway alarms

---

### AlarmSMMSConnectionFailed

The system generates this alarm when the AOL Messenger gateway cannot connect with Simple Messaging Media Store.

#### Severity

Major

#### Alarm description

The connection to the Simple Messaging Store has failed and cannot be reestablished.

#### Additional data

- Simple Messaging Store URL.

### Resolving AlarmSMMSConnectionFailed

#### Procedure

1. Resolve the pending alarms for the Simple Messaging Media Store.
2. Check the configuration of Simple Messaging Media Store.  
For more information, see [Simple Messaging Media Store](#) on page 96.
3. On the **Summary** tab of Simple Messaging Media Store, check the **Service status** field to determine whether Simple Messaging Media Store is running.

---

## AOL Messenger Gateway notifications

---

### NotificationServiceStarted

The system generates this notification when the service for an application starts.

---

### NotificationServiceStopping

The system generates this notification when the service for an application is about to stop.

---

## NotificationRemoteServiceStarted

The system generates this notification when a remote service in the AOL Messenger gateway starts. Before starting, the remote service can be in stopped mode.

### Additional data

- Remote Service Name

---

## NotificationRemoteServiceStopped

The system generates this notification when a remote service in AOL Messenger gateway stops. Before stopping, the remote service can be in started mode.

### Additional data

- Remote Service Name

---

## Communicator Gateway alarms

---

### AlarmSMMSConnectionFailed

The system generates this alarm when the Microsoft Office Communicator gateway cannot connect with Simple Messaging Media Store.

#### Severity

Major

#### Alarm description

The connection to the Simple Messaging Store has failed and cannot be reestablished.

#### Additional data

- Simple Messaging Store URL.

### Resolving AlarmSMMSConnectionFailed

#### Procedure

1. Resolve the pending alarms for the Simple Messaging Media Store.
2. Check the configuration of Simple Messaging Media Store.

For more information, see [Simple Messaging Media Store](#) on page 96.

3. On the **Summary** tab of Simple Messaging Media Store, check the **Service status** field to determine whether Simple Messaging Media Store is running.

---

## Communicator Gateway notifications

---

### NotificationServiceStarted

The system generates this notification when the service for an application starts.

---

### NotificationServiceStopping

The system generates this notification when the service for an application is about to stop.

---

### NotificationRemoteServiceStarted

The system generates this notification when a remote service in the Communicator gateway starts. Before starting, the remote service can be in stopped mode.

#### Additional data

- Remote Service Name

---

### NotificationRemoteServiceStopped

The system generates this notification when a remote service in the Communicator gateway stops. Before stopping, the remote service can be in started mode.

#### Additional data

- Remote Service Name

---

## MSN Messenger Gateway alarms

---

### AlarmSMMSConnectionFailed

The system generates this alarm when the MSN Messenger gateway cannot connect with Simple Messaging Media Store.

#### Severity

Major

#### Alarm description

The connection to the Simple Messaging Store has failed and cannot be reestablished.

#### Additional data

- Simple Messaging Store URL.

### Resolving AlarmSMMSConnectionFailed

#### Procedure

1. Resolve the pending alarms for the Simple Messaging Media Store.
2. Check the configuration of Simple Messaging Media Store.  
For more information, see [Simple Messaging Media Store](#) on page 96.
3. On the **Summary** tab of Simple Messaging Media Store, check the **Service status** field to determine whether Simple Messaging Media Store is running.

---

## MSN Messenger Gateway notifications

---

### NotificationServiceStarted

The system generates this notification when the service for an application starts.

### NotificationServiceStopping

The system generates this notification when the service for an application is about to stop.



---

## NotificationRemoteServiceStarted

The system generates this notification when a remote service in the MSN Messenger gateway starts. Before starting, the remote service can be in stopped mode.

### Additional data

- Remote Service Name

---

## NotificationRemoteServiceStopped

The system generates this notification when a remote service in the MSN Messenger gateway stops. Before stopping, the remote service can be in started mode.

### Additional data

- Remote Service Name

---

## SMS Gateway alarms

---

### AlarmSMMSConnectionFailed

The system generates this alarm when the SMS gateway cannot connect with Simple Messaging Media Store.

#### Severity

Major

#### Alarm description

The connection to the Simple Messaging Store has failed and cannot be reestablished.

#### Additional data

- Simple Messaging Store URL

### Resolving AlarmSMMSConnectionFailed

#### Procedure

1. Resolve the pending alarms for the Simple Messaging Media Store.
2. Check the configuration of Simple Messaging Media Store.

For more information, see [Simple Messaging Media Store](#) on page 96.

3. On the **Summary** tab of Simple Messaging Media Store, check the **Service status** field to determine whether Simple Messaging Media Store is running.

---

## SMS Gateway notifications

---

### NotificationServiceStarted

The system generates this notification when the service for an application starts.

---

### NotificationServiceStopping

The system generates this notification when the service for an application is about to stop.

---

### NotificationRemoteServiceStarted

The system generates this notification when a remote service in the SMS gateway starts. Before starting, the remote service can be in stopped mode.

#### Additional data

- Remote Service Name

---

### NotificationRemoteServiceStopped

The system generates this notification when a remote service in the SMS gateway stops. Before stopping, the remote service can be in started mode.

#### Additional data

- Remote Service Name

---

## Web Chat Gateway alarms

---

### AlarmSMMSConnectionFailed

The system generates this alarm when the Web Chat gateway cannot connect with Simple Messaging Media Store.

**Severity**

Major

**Alarm description**

The connection to the Simple Messaging Store has failed and cannot be reestablished.

**Additional data**

- Simple Messaging Store URL.

### Resolving AlarmSMMSConnectionFailed

**Procedure**

1. Resolve the pending alarms for the Simple Messaging Media Store.
2. Check the configuration of Simple Messaging Media Store.  
For more information, see [Simple Messaging Media Store](#) on page 96.
3. On the **Summary** tab of Simple Messaging Media Store, check the **Service status** field to determine whether Simple Messaging Media Store is running.

---

## Web Chat Gateway notifications

---

### NotificationServiceStarted

The system generates this notification when the service for an application starts.

### NotificationServiceStopping

The system generates this notification when the service for an application is about to stop.

---

## NotificationRemoteServiceStarted

The system generates this notification when a remote service in the Web Chat gateway starts. Before starting, the remote service can be in stopped mode.

### Additional data

- Remote Service Name

---

## NotificationRemoteServiceStopped

The system generates this notification when a remote service in the Web Chat gateway stops. Before stopping, the remote service can be in started mode.

### Additional data

- Remote Service Name

---

## GTalk Gateway alarms

---

### AlarmSMMSConnectionFailed

The system generates this alarm when the GTalk gateway cannot connect with Simple Messaging Media Store.

#### Severity

Major

#### Alarm description

The connection to the Simple Messaging Store failed and cannot be reestablished.

#### Additional data

- Simple Messaging Store URL.

### Resolving AlarmSMMSConnectionFailed

#### Procedure

1. Resolve the pending alarms for the Simple Messaging Media Store.
2. Check the configuration of Simple Messaging Media Store.

For more information, see [Simple Messaging Media Store](#) on page 96.

3. On the **Summary** tab of Simple Messaging Media Store, check the **Service status** field to determine whether Simple Messaging Media Store is running.

---

## GTalk Gateway notifications

---

### NotificationServiceStarted

The system generates this notification when the service for an application starts.

---

### NotificationServiceStopping

The system generates this notification when the service for an application is about to stop.

---

### NotificationRemoteServiceStarted

The system generates this notification when a remote service in the GTalk gateway starts. Before starting, the remote service can be in stopped mode.

#### Additional data

- Remote Service Name

---

### NotificationRemoteServiceStopped

The system generates this notification when a remote service in the GTalk gateway stops. Before stopping, the remote service can be in started mode.

#### Additional data

- Remote Service Name

---

## Virtual Agent alarms

---

### License Director Link Down alarm

The system generates this alarm when the Virtual Agent cannot connect with License Director.

### **Severity**

Major

### **Alarm description**

The link to the License Manager has failed and cannot be reestablished.

## **Resolving License Director Link Down alarm**

### **Procedure**

1. Resolve the pending alarms for License Director.
2. Check the configuration of License Director.  
For more information, see [Configuring License Director](#) on page 100.
3. On the **Summary** tab of License Director, check the **Service status** field to determine whether License Director service is running.

## **No connection to XML Server alarm**

The system generates this alarm when Virtual Agent cannot connect with the XML Server.

### **Severity**

Major

### **Alarm description**

The connection to XML Server is closed.

## **Resolving No connection to XML Server alarm**

### **Procedure**

1. Resolve the pending alarms for XML Server.
2. Check the configuration of Virtual Agent for XML Server settings.  
For more information, see [Configuring Virtual Agent](#) on page 54 and [Configuring an XML server](#) on page 102.
3. On the **Summary** tab of XML Server, check the **Service status** field to determine whether XML Server is running.

## **All Endpoints Busy alarm**

The system generates this alarm when all Virtual Agents are busy.

### **Severity**

Major

### **Alarm description**

All endpoints configured in the specified group are in use.

## Resolving All Endpoints Busy alarm

### Procedure

Add more endpoints to a specified Virtual Agent group.

## Endpoint Busy High Water Mark Reached alarm

The system generates this alarm when the high percentage of Virtual Agents is busy. You can specify the high water percentage in the **Endpoint busy high water percentage (%)** field, while configuring the Virtual Agent group.

For more information, see [Configuring Virtual Agent](#) on page 54.

### Severity

Minor

### Alarm description

A significant percentage of the endpoints configured in this group are in use.

## Resolving Endpoint Busy High Water Mark Reached alarm

### Procedure

Increase the percentage of endpoints for a Virtual Agent group.

## Unable to start ASVirtualMediaClient alarm

The system generates this alarm when an exception occurred while running a program.

### Severity

Major

### Alarm description

Exception stopped execution.

## Resolving Unable to start ASVirtualMediaClient alarm

### Procedure

Check exception details.

## Virtual Agent without license alarm

The system generates this alarm when the Voice licenses are unavailable for Virtual Agent.

### Severity

Minor

### Alarm description

The Virtual Agent has no Voice license. The voice work item is not retrieved.

## **Resolving Virtual Agent without license alarm**

### **Procedure**

Verify if the Voice licenses are available for Virtual Agent on the WebLM server.

## **DMCC Session Failed alarm**

The Device, Media, and Call Control (DMCC) Worker generates this alarm when the system cannot establish a DMCC session with Communication Manager and the DMCC Service of AES.

### **Severity**

Major

### **Alarm description**

Unable to establish DMCC Session to AES and Avaya Aura® CM for DMCC Worker.

## **Resolving DMCC Session Failed alarm**

### **Procedure**

1. Check the connection to AES.
2. Check the configuration of DMCC to ensure that DMCC service is running on AES.
3. Verify if the DMCC server port used in the configuration of AES is enabled.

## **DMCC Endpoint Monitor Failed alarm**

The DMCC Worker generates this alarm when the system establishes a DMCC Session with Communication Manager and DMCC Service of AES, but the DMCC service of AES rejects to start the DMCC monitors.

### **Severity**

Major

### **Alarm description**

The monitor attempt for the specified station was unsuccessful.

## **Resolving DMCC Endpoint Monitor Failed alarm**

### **Procedure**

Check error details to find a reason for DMCC failure.

## **DMCC Endpoint Registration Failed**

The DMCC Worker generates this alarm when the system starts the DMCC monitors, but the DMCC service of AES rejects registering the terminal.

### **Severity**

Major

### **Alarm description**

The registration attempt for the specified station was unsuccessful.



## Resolving DMCC Endpoint Registration Failed Procedure

Check error details to find the reason for DMCC failure.

## Unable to initialize remoting service alarm

The system generates this alarm when the system cannot initialize the remoting service for the Virtual Agent.

### Severity

Major

### Alarm description

The remoting service cannot be set up.

### Additional data

- Exception data

## Resolving Unable to initialize remoting service alarm

### Procedure

1. Verify if the configuration for a remoting service is correct. For more information, see [Configuring Virtual Agent](#) on page 54.
2. Verify if you have correctly set the permissions for a remoting service.

---

# Virtual Agent notifications

---

## License Manager opened connection

The system generates this notification when the service for Virtual Agent connects with License Director.

## VA maintaining started

The system generates this notification when the maintaining thread for Virtual Agents starts.

## DMCC Session Established

The system generates this notification when a DMCC session correctly establishes with the DMCC service of AES.

## **DMCC Endpoint Registered**

The system generates this notification when the DMCC endpoint successfully registers with the DMCC service of AES.

---

## **DMCC Endpoint Monitored**

The system generates this notification when the DMCC service of AES successfully monitors the DMCC endpoint.

---

## **DMCCGroupAssigned**

The system generates this notification when the Virtual Agent management interface assigns a new DMCC group from the currently administered Virtual Agent groups.

---

## **DMCCGroupUnAssigned**

The system generates this notification when the Virtual Agent management interface removes the assignment of a Virtual Agent group.

---

## **DMCCGroupUpdated**

The system generates this notification when the Virtual Agent management interface updates the contents of the Virtual Agent group.

---

## **Daily Maximum Endpoints Occupied**

The system generates this notification to indicate the maximum number of endpoints that are concurrently busy in a Virtual Agent group. The system adds this notification daily, at the end of each day.

---

## XML Server alarms

---

### TServer Link Down alarm

The system generates this alarm when the XML Server cannot connect with the AES TServer.

The system resolves this alarm when the XML Server successfully connects with the AES TServer.

When the XML Server consecutively fails to connect with the AES TServer, the system updates the *Last Attempt* and *Retry Count* variable in the **Additional data** section of the alarm details.

The system also sends this alarm for an ACS stream error when AES and Communication Manager cannot connect with each other. In the **Additional data** section of the alarm details, the value in the **Last Error Code** variable displays the server in which the error occurred.

#### Severity

Major

#### Alarm description

The specified link to the Avaya AES server has failed and cannot be reestablished.

#### Additional data

- TServer Link Name
- Last Error Code
- Last Error Description
- Last Attempt Date/Time
- Retry Count

### Resolving TServer Link Down alarm

#### Procedure

1. Verify if you have correctly configured the TServer.
2. Verify if the AES server is running.

### TServer Login Failure alarm

The system generates this alarm when the XML Server connects with the specified AES TServer, but the XML Server cannot login to the TServer.

The system resolves this alarm when the XML Server successfully logs into the AES TServer.

When the XML Server consecutively tries to login to the AES TServer and fails, the system updates the *Last Attempt* and *Retry Count* variables in the **Additional data** section of the alarm details.

#### Severity

Major

#### Alarm description

The specified link to the AES server has failed and cannot be reestablished.

### **Additional data**

- TServer Link Name
- Last Attempt Date/Time
- Retry Count

### **Resolving TServer Login Failure alarm**

#### **Procedure**

1. Verify if you have correctly configured the TServer.
2. Verify if the AES server is running.

### **License Director Link Down alarm**

The system generates this alarm when the XML Server cannot connect with License Director.

The system resolves this alarm when the XML Server successfully connects with License Director.

#### **Severity**

Major

#### **Alarm description**

The connection to the License Director has failed and cannot be reestablished.

#### **Additional data**

- License Director IP Address
- License Director Port
- Last Attempt Date/Time
- Retry Count

### **Resolving License Director Link Down alarm**

#### **Procedure**

1. Resolve the pending alarms for License Director.
2. Check the configuration of License Director.

For more information, see [Configuring License Director](#) on page 100.

3. On the **Summary** tab of License Director, check the **Service status** field to determine whether License Director service is running.

### **Name Service Failed alarm**

The system generates this alarm when the XML Server cannot open the Name Service port. The system generates this alarm when you configure a port that another service is using. For example, port 80 that is used by a Web server when active.

#### **Severity**

Major.

**Alarm description**

The Name Service is unavailable.

**Additional data**

- Name Service IP Address
- Name Service Port
- Last Attempt Date/Time
- Last Error
- Retry Count

**Resolving Name Service Failed alarm****Procedure**

Check the configuration of XML Server and ensure that the specified Name Service port is not in use.

For more information, see [Configuring an XML server](#) on page 102.

---

## XML Server notifications

---

### NotificationServiceStarted

The system generates this notification when the service for an application starts.

---

### NotificationServiceStopping

The system generates this notification when the service for an application is about to stop.

---

### TServer Link Up

The system generates this notification when the XML Server connects to the AES server and is ready for use.

**Additional data**

- TServer Link Name

# Appendix C: Configuration Files

---

## Configuring Control Panel through .ini file

### About this task

Using this procedure, you can configure control panel through .ini file.

### Procedure

1. In the Windows explorer, navigate to the `\Avaya Aura CC Elite Multichannel\Desktop\CC Elite Multichannel Control Panel` directory.
2. Open the `ASGUIHost.ini` file for editing.

Use the definitions described in the [ASGUIHost.ini file parameter descriptions](#) on page 374 table to define your configuration data.

 **Note:**

Do not change section names or parameter names.

---

## ASGUIHost.ini file parameter descriptions

Name	Description
<b>General</b>	
<b>Language</b>	The language used on the application interface. The only option currently available is English.
<b>Server Instance ID</b>	A unique identifier for the server application that is created automatically when it runs for the first time.
<b>Minimize to System Tray</b>	With this value, you can minimize Call Center Elite Multichannel Control Panel to the system tray as opposed to the taskbar when the application is minimized. True=enabled, False=disabled. The system tray is the area on the right side of the taskbar on the Windows interface that is used to display the status of the functions, such as speaker volume and modem transmission.

*Table continues...*

Name	Description
<b>Window Title</b>	The text that displays on the application title bar. The default is: Call Center Elite Multichannel Control Panel
<b>Window Icon</b>	The name and file path to the icon that displays on the application title bar. If left blank, Call Center Elite Multichannel Control Panel automatically uses the default icon located in the application current working folder. In this case: AMC.ico
<b>Product ID</b>	A number that identifies this application. Do not change the default value.
<b>Enable Options Menu</b>	A value that either enables or disables the <b>Options</b> menu item in the <b>Tools</b> menu.
<b>Enable Slide Tool Window</b>	A value that either enables or disables sliding the tool windows.
<b>Error Logging</b>	
<b>Error Log Level</b>	<p>The value that determines what level of error detail is saved in the error log:</p> <ul style="list-style-type: none"> <li>• 0=No error logging takes place</li> <li>• 1=Logs fatal, major, minor and trace information</li> <li>• 2=Logs fatal, major and minor errors</li> <li>• 4=Logs fatal and major errors</li> <li>• 8=Logs fatal errors only.</li> </ul> <p>There is also another error log level, which enables you to create log files that do not overwrite each other every time the maximum log file size limit is reached. This logging level is designed for diagnostic purposes only and can be achieved by adding 128 to one of the mentioned logging level values.</p> <p>For example, if you specify Error Log Level=129, new error log files are created for this application that contain fatal, major, minor, and trace information.</p>
<b>Error Log File Path</b>	The directory path for saving error log files. By default, this parameter is left blank, which automatically sets the path to the application current working folder that is the similar to the application executable.
<b>Error Log File Extension</b>	The extension of error log files for this application. Extension refers to part of the file name, usually the name of the application, and the file type extension, for example .log. The application automatically precedes the default extension with the day of the

*Table continues...*

Name	Description
	week, for example, Mon, Tue, when it creates its error logs.
<b>Maximum Error Log File Size KB</b>	<p>The maximum amount of information, in KB, that is stored in an error log file before it is archived and a new file is created. The default is 1000. You can set minimum 100.</p> <p> <b>Note:</b></p> <p>The archive stores only one log file. If a second error log reaches the specified maximum size, it overrides the previously archived file. If, the diagnostic testing error log level is selected in <b>Error Log Level</b>, a new file with a new name is created every time the maximum log file size limit is reached. This <b>Error Log Level</b> is achieved by adding 128 to any one of the other error log values.</p>
<b>Error Log Mode</b>	<p>A value that indicate the logging mode for Control Panel.</p> <p>Following are the logging modes:</p> <ul style="list-style-type: none"> <li>1: Enables Classic Logging</li> <li>2: Enables TTrace Logging</li> <li>3: Enables both the logging modes</li> </ul> <p>Default value is: 3.</p>
<b>Error Log TTrace Host</b>	The host name of the TTrace server.
<b>Error Log TTrace Port</b>	The port number to access the TTrace server.
<b>Error Log use old Log Format</b>	A value that instructs the system to store the log either in the new Avaya Common Logging format or the old logging format.
<b>License Director</b>	
<b>Primary License Director IP</b>	The IP address of the primary License Director through which this application request and release licenses.
<b>Primary License Director Port</b>	The port number of the primary License Director. The default is 29095.
<b>Secondary License Director IP</b>	The IP address of the secondary License Director IP through which this application request and release licenses.
<b>Secondary License Director Port</b>	The port number of the secondary License Director. The default is 29095.
<b>Connect License Director</b>	Reserved for future use. Leave set to False.

*Table continues...*



Name	Description
<b>Enable Debug Trace</b>	With this setting, you can debug Call Center Elite Multichannel Control Panel using tools like DebugView. True=enabled, False=disabled.
<b>Window Layout</b>	
<b>Left Position</b>	The distance, in pixels, of the application from the left side of the screen at startup. The distance is automatically saved in the configuration after adjusting within the application.
<b>Top Position</b>	The distance, in pixels, of the application from the top of the screen at startup. The distance is automatically saved in the configuration after adjusting within the application.
<b>Window Width</b>	The width, in pixels, of the application interface. The width is automatically saved in the configuration after adjusting within the application.
<b>Window Height</b>	The height, in pixels, of the application interface. The height is automatically saved in the configuration after adjusting within the application.
<b>Maximized</b>	If set <code>True</code> , the size of the application interface starts in maximized mode. If set <code>False</code> , the size of the application interface starts in normal mode.
<b>Layout File Folder</b>	The file path to the XML file that stores data about the layout of the windows in your version of Call Center Elite Multichannel Desktop. The size and positioning of each window, for example, whether it is docked in a fixed position, floating, or displayed as a tabbed document, is recorded in a file named <code>ASGUIHostLayout_username.xml</code> . If this parameter is blank, by default, Desktop locates the file in the same folder where the application executable is present.
<b>Plug In Assembly List</b>	
<p>This section lists all the loadable generic plug-ins. Each entry has the format "Friendly name=Plug-in section name". The plug-in section name points to the section in the file that contains configuration data for that plug-in. For example:</p> <pre> Application Management Console Section = Application Management Console License Director Manager Section = License Director Manager Media Director Manager Section = Media Director Manager MultiMedia Database Manager Section = MultiMedia Database Manager </pre>	

*Table continues...*

## Configuration Files

Name	Description
Email Control Panel Section = Email Control Panel Simple Messaging Control Panel Section = Simple Messaging Control Panel Voice Control Panel Section = Voice Control Panel XML Server Manager Section = XML Server Manager Preview Contact Control Panel Section = Preview Contact Control Panel Simple Messaging Gateway Manager Section = Simple Messaging Gateway Manager Virtual Agent Control Panel Section = Virtual Agent Control Panel Virtual Agent Outbound Worker Section = Virtual Agent Outbound Worker Manager Virtual Agent Web Service Worker Manager Section = Virtual Agent Web Service Worker Manager Save Close Section = Save Close Contact Database Management Section = Contact Database Management RSS Reader Section = RSS Reader Html Editor Provider Section = Html Editor Provider Templates Management Section = Templates Management Alarm And Notification Viewer Section = Alarm And Notification Viewer Database Deployment Utility Plugin Section = Database Deployment Utility Plugin Communication Manager Administration Plugin Section = CMAdminPlugin ASTaskDirectorManagement Plugin Section = ASTaskDirectorManagement Plugin Section ReportingTaskWorkerAdmin Plugin Section = ReportingTaskWorkerAdmin Plugin Section TaskAccess Plugin Section = TaskAccess Plugin Section DMCC Worker Control Panel Section = DMCC Worker Control Panel Voice Portal Express Plugin Section = Voice Portal Plugin CallRecordingControlPanel Section = CallRecordingControlPanel	
<b>DMCC Worker Control Panel</b>	
<b>Assembly File Name</b>	The name of the plug-in file to be loaded. If the plug-in is not located in the default file path, which is the same folder as the host application, you must also specify the file path.  For this plug-in, use:  ASDMCCWorkerManagementPlugin.dll
<b>ASTaskDirectorManagement Plugin Section</b>	
<b>Assembly File Name</b>	The name of the plug-in file to be loaded. If the plug-in is not located in the default file path, which is the

*Table continues...*

Name	Description
	<p>same folder as the host application, you must also specify the file path.</p> <p>For this plug-in, use:</p> <p>ASTaskDirectorManagementPlugin.dll</p>
<b>ReportingTaskWorkerAdmin Plugin Section</b>	
<b>Assembly File Name</b>	<p>The name of the plug-in file to be loaded. If the plug-in is not located in the default file path, which is the same folder as the host application, you must also specify the file path.</p> <p>For this plug-in, use:</p> <p>ReportingTaskWorkerAdminPlugin.dll</p>
<b>TaskAccess Plugin Section</b>	
<b>Assembly File Name</b>	<p>The name of the plug-in file to be loaded. If the plug-in is not located in the default file path which is the same folder as the host application, you must also specify the file path.</p> <p>For this plug-in, use:</p> <p>TaskAccessPlugin.dll</p>
<b>Alarm And Notification Viewer</b>	
<b>Assembly File Name</b>	<p>The name of the plug-in file to be loaded. If the plug-in is not located in the default file path, which is the same folder as the host application, you must also specify the file path.</p> <p>For this plug-in, use:</p> <p>ASAlarmAndNotificationViewerPlugin.dll</p>
<b>Templates Management</b>	
<b>Assembly File Name</b>	<p>The name of the plug-in file to be loaded. If the plug-in is not located in the default file path, which is the same folder as the host application, you must also specify the file path.</p> <p>For this plug-in, use:</p> <p>ASTemplateManagementPlugin.dll</p>
<b>Html Editor Provider</b>	
<b>Assembly File Name</b>	<p>The name of the plug-in file to be loaded. If the plug-in is not located in the default file path, which is the same folder as the host application, you must also specify the file path.</p> <p>For this plug-in, use:</p>

*Table continues...*

Name	Description
	ASGUIHHtmlEditorProviderPlugin.dll
<b>Contact Database Management</b>	
<b>Assembly File Name</b>	<p>The name of the plug-in file to be loaded. If the plug-in is not located in the default file path, which is the same folder as the host application, you must also specify the file path.</p> <p>For this plug-in, use: ASContactDatabaseManagementPlugin.dll</p>
<b>Application Management Console</b>	
<b>Assembly File Name</b>	<p>The name of the plug-in file to be loaded. If the plug-in is not located in the default file path, which is the same folder as the host application, you must also specify the file path.</p> <p>For this plug-in, use: ASApplicationManagementConsolePlugin.dll</p>
<b>Multicast IP</b>	<p>The IP address that the system uses for multicasting between applications. When an application starts, it joins this multicast address and receives packet information from the Application Management Director.</p> <p>The default is 239.29.9.67.</p>
<b>Multicast Port</b>	<p>The port number that the system uses for multicasting between applications. The default is 29075.</p>
<b>Enable Multicast</b>	<p>A setting that determines if multicasting is enabled or not. True=enabled, False=disabled.</p>
<b>Application Management Director URL List</b>	<p>A list of URLs for the Application Management Directors set up in your contact center. Items are separated by commas and follow the format: gtcp://192.168.10.201:29074/ ApplicationManagementDirector.rem.</p>
<b>RSS Reader</b>	
<b>Assembly File Name</b>	<p>The name of the plug-in file to be loaded. If the plug-in is not located in the default file path, which is the same folder as the host application, you must also specify the file path.</p> <p>For this plug-in, use: ASRSSReader.dll</p>
<b>License Director Manager</b>	
<b>Assembly File Name</b>	<p>The name of the plug-in file to be loaded. If the plug-in is not located in the default file path, which is the</p>

Table continues...

Name	Description
	<p>same folder as the host application, you must also specify the file path.</p> <p>For this plug-in, use: ASLicenseDirectorManagementPlugin.dll</p>
<b>Media Director Manager</b>	
<b>Assembly File Name</b>	<p>The name of the plug-in file to be loaded. If the plug-in is not located in the default file path, which is the same folder as the host application, you must also specify the file path.</p> <p>For this plug-in, use: ASMediaDirectorManagementPlugin.dll</p>
<b>Multimedia Database Manager</b>	
<b>Assembly File Name</b>	<p>The name of the plug-in file to be loaded. If the plug-in is not located in the default file path, which is the same folder as the host application, you must also specify the file path.</p> <p>For this plug-in, use: ASMultimediaDatabaseManagementPlugin.dll</p>
<b>Email Control Panel</b>	
<b>Assembly File Name</b>	<p>The name of the plug-in file to be loaded. If the plug-in is not located in the default file path which is the same folder as the host application, you must also specify the file path.</p> <p>For this plug-in, use: ASEmailManagementPlugin.dll</p>
<b>Simple Messaging Control Panel</b>	
<b>Assembly File Name</b>	<p>The name of the plug-in file to be loaded. If the plug-in is not located in the default file path which is the same folder as the host application, you must also specify the file path.</p> <p>For this plug-in, use: ASSimpleMessagingManagementPlugin.dll</p>
<b>Voice Control Panel</b>	
<b>Assembly File Name</b>	<p>The name of the plug-in file to be loaded. If the plug-in is not located in the default file path, which is the same folder as the host application, you must also specify the file path. For this plug-in, use: ASVoiceManagementPlugin.dll</p>
<b>Display Call From/To</b>	
<b>XML Server Manager</b>	

*Table continues...*

Name	Description
<b>Assembly File Name</b>	<p>The name of the plug-in file to be loaded. If the plug-in is not located in the default file path, which is the same folder as the host application, you must also specify the file path.</p> <p>For this plug-in, use: ASXMLServerManagementPlugin.dll</p>
<b>Preview Contact Control Panel</b>	
<b>Assembly File Name</b>	<p>The name of the plug-in file to be loaded. If the plug-in is not located in the default file path, which is the same folder as the host application, you must also specify the file path.</p> <p>For this plug-in, use: ASPreviewContactManagementPlugin.dll</p>
<b>Simple Messaging Gateway Manager</b>	
<b>Assembly File Name</b>	<p>The name of the plug-in file to be loaded. If the plug-in is not located in the default file path, which is the same folder as the host application, you must also specify the file path.</p> <p>For this plug-in, use: ASSMGatewayManagementPlugin.dll</p>
<b>Virtual Agent Control Panel</b>	
<b>Assembly File Name</b>	<p>The name of the plug-in file to be loaded. If the plug-in is not located in the default file path, which is the same folder as the host application, you must also specify the file path.</p> <p>For this plug-in, use: ASVirtualAgentManagementPlugin.dll</p>
<b>Virtual Agent Web Service Worker Manager</b>	
<b>Assembly File Name</b>	<p>The name of the plug-in file to be loaded. If the plug-in is not located in the default file path, which is the same folder as the host application, you must also specify the file path.</p> <p>For this plug-in, use: ASVAWSWorkerManagementObject.dll</p>
<b>Virtual Agent Outbound Worker Manager</b>	
<b>Assembly File Name</b>	<p>The name of the plug-in file to be loaded. If the plug-in is not located in the default file path, which is the same folder as the host application, you must also specify the file path.</p> <p>For this plug-in, use: ASOutboundWorkerManagementPlugin.dll</p>

*Table continues...*

Name	Description
<b>Save Close</b>	
<b>Assembly File Name</b>	The name of the plug-in file to be loaded. If the plug-in is not located in the default file path, which is the same folder as the host application, you must also specify the file path.  For this plug-in, use: <code>ASSaveClosePlugin.dll</code>
<b>Database Deployment Utility Plugin</b>	
<b>Assembly File Name</b>	The name of the plug-in file to be loaded. If the plug-in is not located in the default file path, which is the same folder as the host application, you must also specify the file path.  For this plug-in, use: <code>ASCCEDBDeploymentUtilityPlugin.dll</code>
<b>CMAdminPlugin</b>	
<b>Assembly File Name</b>	The name of the plug-in file to be loaded. If the plug-in is not located in the default file path, which is the same folder as the host application, you must also specify the file path.  For this plug-in, use: <code>CMAdminPlugin.dll</code>
<b>Voice Portal Plugin</b>	
<b>Assembly File Name</b>	The name of the plug-in file to be loaded. If the plug-in is not located in the default file path, which is the same folder as the host application, you must also specify the file path.  For this plug-in, use: <code>Voice Portal Editor.dll</code>
<b>CallRecordingControlPanel</b>	
<b>Assembly File Name</b>	The name of the plug-in file to be loaded. If the plug-in is not located in the default file path, which is the same folder as the host application, you must also specify the file path.  For this plug-in, use: <code>CallRecordingControlPanel.dll</code>

---

## Configuring License Director through .ini file

### About this task

Using this procedure, you can configure license director through .ini file.

## Procedure

1. In the Windows explorer, navigate the `\Avaya Aura CC Elite Multichannel\Server\License Director` directory.
2. Open the `ASLicenseDirector.ini` file for editing.

Use the definitions described in the [ASLicenseDirector.ini file parameter descriptions](#) on page 384 table to define your configuration data.

**\* Note:**

Do not change section names or parameter names.

## ASLicenseDirector.ini file parameter descriptions

Name	Description
<b>General</b>	
<b>Server Instance ID</b>	A unique identifier for the server application, which is created automatically when it runs for the first time.
<b>Client Connections IP</b>	The local IP address to which the client connects.
<b>Client Connections Port</b>	The IP port number to which the client connects. Default is 29095.
<b>XML Transfer Log</b>	If the License Director has to be set to log data for the XML Transfer Server component for debugging purposes, set this parameter to <code>True</code> .  Default is <code>False</code> .
<b>Master Server Management Object URL</b>	This parameter is configured through Control Panel. For more information, see <a href="#">Configuring License Director</a> on page 100.
<b>WebLM Server URL</b>	The URL of the WebLM Server
<b>WebLM Renew Interval</b>	Renew time in seconds.  Default is 30 seconds
<b>Error Logging</b>	See <a href="#">Error Logging</a> on page 339.
<b>Application Management Service</b>	See <a href="#">Application Management Service common configurable components</a> on page 413.

## Configuring XML Server through .ini file

### About this task

Using this procedure, you can configure XML server through .ini file.



## Procedure

1. In the Windows explorer, navigate to the `\Avaya Aura CC Elite Multichannel\Server\XML Server` directory.
2. Open the `AXMLServer.ini` file for editing.

Use the definitions described in the [AXMLServer.ini file parameter descriptions](#) on page 385 table to define your configuration data.

**\* Note:**

Do not change section names or parameter names.

---

## AXMLServer.ini file parameter descriptions

Name	Description
<b>General</b>	
<b>Server Instance ID</b>	A unique identifier for the server application, which is created automatically when it runs for the first time.
<b>Application Management Service</b>	See <a href="#">Application Management Service common configurable components</a> on page 413.
<b>XML Name Service</b>	See <a href="#">Edit XML Server field descriptions</a> on page 102.
<b>License Director</b>	See <a href="#">Edit XML Server field descriptions</a> on page 102.
<b>Error Logging</b>	See <a href="#">Error Logging</a> on page 339.
<b>Telephony Server 1</b>	See <a href="#">Add Telephony Server field descriptions</a> on page 43.

---

## Configuring Media Director through .ini file

### About this task

Using this procedure, you can configure Media Director through .ini file.

### Procedure

1. In the Windows explorer, navigate the `\Avaya Aura CC Elite Multichannel\Server\Media Director` directory.
2. Open the `ASMediaDirector.ini` file for editing.

Use the definitions described in the [ASMediaDirector.ini file parameter descriptions](#) on page 386 table to define your configuration data.

**\* Note:**

Do not change section names or parameter names.

## ASMediaDirector.ini file parameter descriptions

Name	Description
<b>General</b>	
<b>Primary License Director IP</b>	The IP address of the primary License Director server.
<b>Primary License Director Port</b>	The port number to access the primary License Director server.
<b>Secondary License Director IP</b>	The IP address of the secondary License Director server.
<b>Secondary License Director Port</b>	The port number to access the secondary License Director server.
<b>Enable Telephony Trace Logging</b>	With this setting, you can log trace information for XML Client telephony operations. True=enabled, False=disabled.
<b>Enable Debug Trace</b>	With this setting, you can debug Agent using tools such as, DebugView. True=enabled, False=disabled.
<b>Process Interval Milliseconds</b>	How regularly, in milliseconds, Media Director processes media store work items. Media Director processes work items fast if the value is small, but consumes more system resource on the running machine. The valid value range is between 100 to 3000. The default value is 500.
<b>Telephony Operation Delay Milliseconds</b>	The number of milliseconds between each telephony operation that Media Director sends to the Telephony Server. For example, if the value is set 100 and Media Director requires to make 20 phantom calls to deliver a set of work items, it pauses for 100 milliseconds before making next call. This setting reduces peak pressure on XML Server and the Telephony Server. If the value is small, the load gets higher on both servers. The valid value is between 0 to 5000. If the value is assigned as 0, there is no delay. The default value is 100.
<b>Server Instance ID</b>	A unique identifier for the server application, which is created automatically when it runs for the first time.
<b>Error Logging</b>	See <a href="#">Error Logging</a> on page 339.
<b>Clients</b>	

*Table continues...*

Name	Description
<b>Maximum Client Connections</b>	The maximum number of inbound client connections that can be active anytime. If this parameter is 0, there is no limit to the number of supported client connections.
<b>Sponsor Audit Interval Seconds</b>	The time interval, in seconds, the KeepAlive method must be called to keep the client connection alive.
<b>Media Stores</b>	
<b>Sponsor Audit Interval Seconds</b>	The time interval, in seconds, the KeepAlive method must be called to keep the media store connection alive.
<b>Queues</b>	
<b>Queue Type</b>	The queue that Media Director uses to distribute calls to available agents. 0=Switch, 1=InternalMI (reserved, currently not supported).
<b>Primary XML Server IP</b>	The IP address of the primary XML server.
<b>Primary XML Server Port</b>	The port number to access the primary XML server.
<b>Secondary XML Server IP</b>	The IP address of the secondary XML server.
<b>Secondary XML Server Port</b>	The port number to access the secondary XML server.
<b>Primary Link Name</b>	The link to connect to the primary XML server.
<b>Secondary Link Name</b>	The link to connect to the secondary XML server.
<b>Phantom Station Busy Interval Minutes</b>	<p>The length of time, in minutes, a station remains busy on a phantom call before the Media Director reuses the station to make another phantom call.</p> <p>The server does this if all stations are busy and the first call in the list exceeds the stated time. When all stations are busy, it indicates that there are no available stations that the server can use to deliver a new incoming work item.</p> <p>After the stated time, the stations can still be flagged as busy if there is a fault in the server fault or there are too many agents exceeding the expected average talk time.</p>
<b>Snapshot Phantom Station Interval Minutes</b>	How regularly, in minutes, Media Director snapshots or checks the phantom stations to verify if there are phantom calls.
<b>Recycle Phantom Call Interval Minutes.</b>	The length of time, in minutes, a phantom call remains in a queue to a VDN waiting to be answered before the call is cleared and redialled. The default value is 60. To disable phantom call recycling, set the value to 0.

*Table continues...*

Name	Description
<b>Maximum Time To Answer Seconds</b>	The length of time, in seconds, a phantom call rings unanswered on an agent voice station before the phantom call is dropped and sent to another available agent logged into the VDN. This value must not be less than 60 seconds and must be used as a secondary measure to Redirect on No Answer (RONA). To disable this feature, set the value to 0.
<b>Maximum Time In Agent Queue Seconds</b>	The length of time, in seconds, a phantom call remains in the agent queue in undelivered state. The default value is 4 minutes. To disable this feature, set the value to 0.
<b>Queue 1</b>	See <a href="#">Add Queue field descriptions</a> on page 132.
<b>Queue 2</b>	The parameters in [Queue 1] are repeated for each queue that you want to configure. There is no limit for the number of queues provided the queues are listed in order.
<b>Application Management Service</b>	See <a href="#">Application Management Service common configurable components</a> on page 413.

---

## Configuring Virtual Agent through .ini file

### About this task

Using this procedure, you can configure Virtual Agent through .ini file.

### Procedure

1. In the Windows explorer, navigate the `\Avaya Aura CC Elite Multichannel\Server\Virtual Agent` directory.
2. Open the `ASVirtualAgent.ini` file for editing.

Use the definitions described in the [ASVirtualAgent.ini file parameter descriptions](#) on page 389 table to define your configuration data.

 **Note:**

Do not change section names or parameter names.

## ASVirtualAgent.ini file parameter descriptions

Name	Description
<b>Service Plug In Host</b>	See <a href="#">Service Plug-in Host common configurable components</a> on page 422.
<b>Error Logging</b>	See <a href="#">Error Logging</a> on page 339.
<b>Plug In Assembly List</b> This section lists all loadable generic plug-ins. Each entry has the format <code>Friendly name=Plug-in section name</code> . The plug-in section name points to the section in the file that contains configuration data for that plug-in.	
<b>Virtual Agent Section</b>	Virtual Agent
<b>Outbound Worker Section</b>	Outbound Worker
<b>Virtual Agent Web Service Worker Section</b>	Virtual Agent Web Service Worker
<b>DMCC Worker Section</b>	DMCC Worker
<b>Server Identifier</b>	See <a href="#">Server Identifier common configurable components</a> on page 421.
<b>Application Management Service</b>	See <a href="#">Application Management Service common configurable components</a> on page 413.
<b>Client Connections</b>	See <a href="#">Client connections common configurable components</a> on page 414.
<b>License Director</b>	See <a href="#">Configuring Virtual Agent</a> on page 54.
<b>Virtual Agent</b>	
<b>Assembly File Name</b>	The name of the plug-in file to be loaded. If the plug-in is not located in the default file path, which is the same folder as the host application, also specify the file path.  For this plug-in, use: <code>ASVirtualAgent.dll</code>
<b>Plugin ID</b>	A globally unique identifier (GUID) that identifies this plug-in.
<b>Get Outbound Programs Interval Minutes</b>	How often, in minutes, Virtual Agent polls media stores for a list of outbound programs being used by their queues. The minimum value is 5 minutes .
<b>Enable Retrieving Voice Work Item</b>	Set this parameter to true to enable retrieval of Voice work items.
<b>Trace Settings</b>	
<b>Outbound Worker</b>	See <a href="#">Configuring Virtual Agent</a> on page 54.
<b>Media Director</b>	See <a href="#">Configuring Virtual Agent</a> on page 54.

*Table continues...*

Name	Description
XML Server	See <a href="#">Configuring XML Server for Virtual Agent</a> on page 55.
Virtual Agent Group A	See <a href="#">Configuring a Virtual Agent group</a> on page 57.

## Configuring Email Media Store through .ini file

### About this task

Using this procedure, you can configure Email Media Store (EMS) through .ini file.

### Procedure

1. In the Windows explorer, navigate the `\Avaya Aura CC Elite Multichannel\Server\Media Stores\Email Media Store` directory.
2. Open the `ASEmailMediaStore.ini` file for editing.

Use the definitions described in the [ASEmailMediaStore.ini file parameter descriptions](#) on page 390 table to define your configuration data.

 **Note:**

Do not change section names or parameter names.

## ASEmailMediaStore.ini file parameter descriptions

Name	Description
Service Plug In Host	See <a href="#">Service Plug-in Host common configurable components</a> on page 422.
Error Logging	See <a href="#">Error Logging</a> on page 339.
Server Identifier	See <a href="#">Server Identifier common configurable components</a> on page 421.
License Director	See <a href="#">Configuring License Director</a> on page 100.
Application Management Service	See <a href="#">Application Management Service common configurable components</a> on page 413.
Client Connections	See <a href="#">Client connections common configurable components</a> on page 414.
Media Store	
Media Store Name	A unique name for this media store. The media store passes this name to the Media Director.

*Table continues...*

Name	Description
<b>Media Store URL</b>	The URL used by remoting clients to connect to this media store. The URL must use the following format: gtcp://FullyQualifiedComputerName:29097/EmailQueueManager.rem.
<b>Queue Progress Update Interval Seconds</b>	How often, in seconds, the media store fires the QueueProgressUpdate event. This event communicates information about the status of queue and how many work items in the queue are in the established, queued, or pending state. The minimum is 10 seconds, the maximum is 3600.
<b>Queue Synchronization Interval Seconds</b>	
<b>Enable Log Loaded Configuration</b>	If set <code>True</code> , this parameter creates log files that record what email queues have loaded, and what database and Media Director the EMS is connected to.
<b>Media Director</b>	See <a href="#">Edit Email Media Store field descriptions</a> on page 135
<b>Database</b>	See <a href="#">Edit Email Media Store field descriptions</a> on page 135
<b>AS Contact Database</b>	See <a href="#">Edit Email Media Store field descriptions</a> on page 135
<b>Auto Reply Email Rules</b>  With this optional section, you can prevent out-of-office replies queuing to the media store. If the text specified in one of the rules matches, which displays in an incoming email Subject field, the email is discarded. You can set up as many rules as you require.	
<b>Rule n</b>	The text that displays in any part of the Subject field and cause the email to be discarded. Usually, the text is set up by default in the company email system.  The rule must use regular expression to increase your control over the accuracy of the match. For example, to discard an email which contains "Auto-reply" at beginning of the subject, use the rule: Rule 1 = ^Auto-reply  However, for a regular expression, you can use a normal string of text. For example, if you want to discard an email which contains "Out of Office" in any part of the subject, use the rule: Rule 1 = Out of Office
<b>Error In Sending Email Rules .</b>	

*Table continues...*

Name	Description
<p>With this optional section, you can forward emails with sent errors to an administrator, configured for the email queue that received the email. Each rule consists of two parts separated by a comma. If the text before the comma matches that which displays in an incoming email's From field, and the text after the comma matches that which displays in the Subject field, the email is forwarded. You can set up as many rules as you require</p>	
<p><b>Rule n</b></p>	<p>The two pieces of text that appears in any part of the From and Subject fields and cause the email to be forwarded. For example: Rule 1=System Administrator, Undeliverable</p> <p>In most cases, the text is that which is set up by default in the company email system.</p> <p> <b>Note:</b></p> <p>If you have programming expertise, you can use regular expression to increase your control over the accuracy of the match. For example: Rule 1=System Administrator, ^Undeliverable.</p> <p>Currently there are two hard-coded rules that work by default:</p> <p>Rule 10=System Administrator, ^Undeliverable</p> <p>If the <b>From</b> field contains “System Administrator” and the <b>Subject</b> field starts with “Undeliverable”, the email is forwarded.</p> <p>Rule 20=postmaster@, (delivery).*(failure)</p> <p>If the <b>From</b> field contains “postmaster@” and the <b>Subject</b> field contains “delivery” and “failure”, the email is forwarded.</p>
<p><b>Template</b></p>	
<p><b>Template Information File</b></p>	
<p><b>Templates Path</b></p>	
<p><b>Plug In Assembly List</b></p> <p>This section lists all loadable generic plug-ins. Each entry has the format <code>Friendly name=Plug-in section name</code>. The plug-in section name points to the section in the file that contains configuration data for that plug-in.</p>	
<p><b>Master</b></p>	<p>Master</p>
<p><b>POP3 Receiver</b></p>	<p>POP3 Receiver</p>

*Table continues...*



Name	Description
<b>Pre Processors</b>	Pre Processors
<b>Post Processors</b>	Post Processors
<b>SMTP Sender</b>	SMTP Sender
<b>IDS Media Store Plugin</b>	IDS Media Store Plugin
<b>Master</b>	
<b>Plugin ID</b>	A globally unique identifier (GUID) that identifies this plug-in.
<b>Enable Error Logging</b>	With this setting, you can write plug-in specific error information to the application error log files. True=enabled, False=disabled.
<b>Assembly File Name</b>	The name of the plug-in file to be loaded. If the plug-in is not located in the default file path, which is the same folder as the host application, also specify the file path.  For this plug-in, use <code>ASEmailMediaStore.Master.dll</code> .
<b>POP3 Receiver</b>	
<b>Plugin ID</b>	A globally unique identifier (GUID) that identifies this plug-in.
<b>Enable Error Logging</b>	With this setting, you can write plug-in specific error information to the application error log files. True=enabled, False=disabled.
<b>Assembly File Name</b>	The name of the plug-in file to be loaded. If the plug-in is not located in the default file path (the same folder as the host application), also specify the file path.  For this plug-in, use <code>ASEmailMediaStore.POP3Receiver.dll</code> .
<b>Pre Processors</b>	
<b>Plugin ID</b>	A globally unique identifier (GUID) that identifies this plug-in.
<b>Enable Error Logging</b>	With this setting, you can write plug-in specific error information to the application error log files. True=enabled, False=disabled.
<b>Assembly File Name</b>	The name of the plug-in file to be loaded. If the plug-in is not located in the default file path, which is the same folder as the host application, also specify the file path.  For this plug-in, use <code>ASEmailMediaStore.PreProcessors.dll</code> .

*Table continues...*

Name	Description
<b>Preprocessors</b>	<p>A list of components that is applied to an incoming email to determine how it should be handled. Do not change the default values:</p> <p>A ,                      ASEmailMediaStore.PreProcessorContactID.dll   B ,                      ASEmailMediaStore.PreProcessorLoopEmail.dll   C ,                      ASEmailMediaStore.PreProcessorUnsupportedEmail.dll   D ,                      ASEmailMediaStore.PreProcessorAutoReply.dll   E ,                      ASEmailMediaStore.PreProcessorErrorInSending.dll   F ,                      ASEmailMediaStore.PreProcessorBinaryEmail.dll   G ,                      ASEmailMediaStore.PreProcessorREResponse.dll   H ,                      ASEmailMediaStore.PreProcessorLastAgentRouting.dll   I ,                      ASEmailMediaStore.PreProcessorValidateContact.dll   J ,                      ASEmailMediaStore.PreProcessorDefault.dll</p>
<b>Pre Processors</b>	
<b>Plugin ID</b>	A globally unique identifier (GUID) that identifies this plug-in.
<b>Enable Error Logging</b>	A setting that allows you to write plug-in specific error information to the application's error log files. True=enabled, False=disabled.
<b>Assembly File Name</b>	<p>The name of the plug-in file to be loaded. If the plug-in is not located in the default file path, which is the same folder as the host application, also specify the file path.</p> <p>For this plug-in, use                      ASEmailMediaStore.PostProcessors.dll.</p>
<b>Postprocessors</b>	<p>A list of components that is applied to an outgoing email to determine how it should be handled. Do not change the default values:</p> <p>A ,                      ASEmailMediaStore.PostProcessorAutomaticBcc.dll   B ,                      ASEmailMediaStore.PostProcessorAutoFooterText.dll</p>

*Table continues...*

Name	Description
<b>SMTP Sender</b>	
<b>Plugin ID</b>	A globally unique identifier (GUID) that identifies this plug-in.
<b>Enable Error Logging</b>	With this setting, you can write plug-in specific error information to the application error log files. True=enabled, False=disabled.
<b>Assembly File Name</b>	The name of the plug-in file to be loaded. If the plug-in is not located in the default file path, which is the same folder as the host application, also specify the file path.  For this plug-in, use <code>ASEmailMediaStore.SMTPSender.dll</code> .
<b>IDS Media Store Plugin</b>	
<b>Plugin ID</b>	An ID automatically created by the plug-in when it first runs. Leave blank.
<b>Enable Error Logging</b>	With this setting, you can write plug-in specific error information to the application error log files. True=enabled, False=disabled.
<b>Assembly File Name</b>	The name of the plug-in file to be loaded. If the plug-in is not located in the default file path, which is the same folder as the media store application, also specify the file path.  For this plug-in, use <code>ASIDSMediaStorePlugin.dll</code>
<b>Server Instance Auto Connect Type</b>	If this value is same as the Server Instance Type specified within Interaction Data Server - Multimedia configuration, a connection with the Interaction Data Server - Multimedia is automatically established when this application starts up. Typically, you leave the default value, which is the well-known GUID of Interaction Data Server - Multimedia.   <b>Note:</b>  The automatic connection also relies on multicasting being enabled and the Multicast IP and Multicast Port being the same as those specified within Interaction Data Server - Multimedia configuration.
<b>Enable Trace</b>	With this setting, you can send application error information to the debug window. True=enabled, False=disabled.
<b>Enable Multicast</b>	

*Table continues...*

Name	Description
<b>Local Address</b>	If you leave this parameter blank, the local address of machine is automatically used to establish a connection with Interaction Data Server - Multimedia. If the machine has more than one network card, you can specify the one you want to use.
<b>Multicast IP</b>	The IP address that is used for multicasting between applications. The default is 239.29.9.67.
<b>Multicast Port</b>	The port number that is used for multicasting between applications. The default is 29078.
<b>IDS Multimedia Connections List</b>	
<b>Receive Buffer Length</b>	The maximum number of events that can be saved in the IDS Media Store Plug-in internal queue. If the connection between the plug-in and the Interaction Data Server - Multimedia is working, the queue is usually empty. If the connection is lost, events sent to the plug-in are retained until the connection is reestablished.  Default is 20000.

---

## Configuring Preview Contact Media Store through .ini file

### About this task

To configure Preview Contact Media Store:

### Procedure

1. In the Windows explorer, navigate to the `\Avaya Aura® CC Elite Multichannel \Server\Media Stores\Preview Contact Media Store` directory.
2. Open the `ASPreviewContactMediaStore.ini` file for editing.

Use the definitions described in the *ASPreviewContactMediaStore.ini file parameter descriptions* table to define your configuration data.

 **Note:**

Do not change section names or parameter names.

## ASPreviewContactMediaStore.ini file parameter descriptions

Name	Description
<b>General</b>	
<b>Media Store Name</b>	A unique name for this media store. The media store passes this name to the Media Director.
<b>Media Store URL</b>	The URL used by remoting clients to connect to this media store. The URL must use the following format: gtcp://FullyQualifiedComputerName:29098/PreviewContact.rem.
<b>QueueProgressUpdate Event Fire Interval Seconds</b>	How often, in seconds, Preview Contact Media Store fires the QueueProgressUpdate event.  Default is 10 seconds.
<b>Polling Program Schedule Interval Seconds</b>	
<b>Server Identifier</b>	See <a href="#">Server Identifier common configurable components</a> on page 421.
<b>Media Director</b>	See <a href="#">Configuring Preview Contact Media Store</a> on page 211
<b>Seconds Before Work Item Expires In Media Director Queue</b>	The duration, in seconds, Media Director holds work items from this media store. If a queued work item exceeds this interval, the work item is removed from the queue and the media store is notified to resend. If set to 0, work items never expires.
<b>Database</b>	See <a href="#">Configuring Preview Contact Media Store</a> on page 211
<b>Error Logging</b>	See <a href="#">Configuring Preview Contact Media Store</a> on page 211
<b>Application Management Service</b>	See <a href="#">Application Management Service common configurable components</a> on page 413.
<b>Plug In Assembly List</b>	
	This section lists all loadable generic plug-ins. Each entry has the format Friendly name=Plug-in section name. The plug-in section name points to the section in the file that contains configuration data for that plug-in. For example: IDS Media Store Plugin = IDS Media Store Plugin ;Microsoft Dynamics CRM Svc Plugin = Microsoft Dynamics CRM Svc Plugin. To enable the Microsoft Dynamics CRM Svc Plugin, remove the semicolon.
<b>IDS Media Store Plugin</b>	See <a href="#">IDS Media Store Plugin common configurable components</a> on page 418

*Table continues...*

Name	Description
<p><b>Microsoft Dynamics CRM Svc Plugin</b></p> <p>With the following plug-in, you can deliver Microsoft Dynamics CRM activities such as task, email, fax, letter, phone call, campaign response, appointment, or service to a public Microsoft Dynamics CRM queue, which Call Center Elite Multichannel Desktop can collect and distribute to call center agents. For more information about how to integrate Microsoft Dynamics CRM, see <i>Avaya Aura® Call Center Elite Multichannel Desktop User Guide</i>.</p>	
<p><b>Assembly File Name</b></p>	<p>The name of the plug-in file to be loaded. If the plug-in is not located in the default file path, which is the same folder as the host application, specify the file path.</p>
<p><b>Enable Error Logging</b></p>	<p>With this setting, you can write plug-in specific error information to the application error log files. True=enabled, False=disabled.</p>
<p><b>Microsoft Dynamics CRM Login User Name</b></p>	<p>The user name for logging into Microsoft Dynamics CRM Webservices.</p>
<p><b>Microsoft Dynamics CRM Login User Password</b></p>	<p>The password associated with the mentioned user name.</p>
<p><b>Microsoft Dynamics CRM Domain Name</b></p>	<p>The domain name of the CRM system.</p>
<p><b>Microsoft Dynamics CRM Web Service URL</b></p>	<p>The URL of the Microsoft Dynamics CRM CrmService. The default is: <a href="http://YourMSCRMServer/mscrmservices/2007/crmService.asmx">http://YourMSCRMServer/mscrmservices/2007/crmService.asmx</a>.</p>
<p><b>Microsoft Dynamics CRM Web Service Reconnect Interval</b></p>	<p>When the connection to the Microsoft Dynamics CRM Web Service has failed, this value determines, how often, in seconds, MS CRM Svc Plug-in waits before attempting to reconnect it. The default is 300.</p>
<p><b>Microsoft Dynamics CRM Organization Name</b></p>	<p>The organization name of the CRM system.</p>
<p><b>Microsoft Dynamics CRM Public Queues Workflowed Via CCE</b></p>	<p>The name of the public queue that the MS CRM Svc plug-in checks for new activities and the name of the Call Center Elite Multichannel program ID MS CRM Svc plug-in uses. The parameter takes the format Microsoft Dynamics CRM Public Queues Workflowed Via CCE=MSCRMPublicQueueName:CCEPreviewContactProgramId</p> <p>If you want to workflow Microsoft Dynamics CRM activities through more than two public queues, separate the values with a comma.</p>

Table continues...

Name	Description
	For example, Microsoft Dynamics CRM Public Queues Workflowed Via CCE=MSCRMPublicQueueName:CCEPreviewContactProgramId, MSCRMPublicQueueName:CCEPreviewContactProgramId.
<b>Microsoft Dynamics CRM Public Queues Check Interval</b>	How often, in seconds, the MS CRM Svc plug-in checks Microsoft Dynamics CRM public queues for new activities to distribute to call center agents. The default is 300.
<b>Service Restart Synchronization Wait Interval</b>	<p>When Microsoft Dynamics CRM work items are already created but not yet delivered to agents, Preview Contact Media Store has to restart. This parameter determines the time, in seconds, the MS CRM Svc plug-in waits for the media store to tell the total number of remaining items in the ASMediaStore Database. After this interval, the plug-in start checking the Microsoft Dynamics CRM public queue again for activities. The plug-in ignores any activities for which Microsoft Dynamics CRM work items already exist. The default is 300.</p> <p> <b>Note:</b></p> <p>The number of work items that can queue inside Media Director is larger than the number of Microsoft Dynamics CRM work items that can remain in the ASMediaStore Database when Preview Contact Media Store shuts down. The preferable setting is 100 or more.</p>

## Configuring Voice Media Store through .ini file

### About this task

To configure Voice Media Store:

### Procedure

1. In the Windows explorer, navigate to the `\Avaya Aura® CC Elite Multichannel \Server\Media Stores\Voice Media Store` directory.
2. Open the `ASVoiceMediaStore.ini` file for editing.

Use the definitions described in the *ASVoiceMediaStore.ini file parameter descriptions* table to define your configuration data.

**\* Note:**

Do not change section names or parameter names.

## ASVoiceMediaStore.ini file parameter descriptions

Name	Description
<b>Service Plug In Host</b>	See <a href="#">Service Plug-in Host common configurable components</a> on page 422.
<b>Error Logging</b>	See <a href="#">Edit Voice Media Store field descriptions</a> on page 115.
<b>Plug In Assembly List</b> This section lists all loadable generic plug-ins. Each entry has the format <code>Friendly name=Plug-in section name</code> . The plug-in section name points to the section in the file that contains configuration data for that plug-in. For example: Voice Media Store Plug In = Voice Media Store IDS Media Store Plug In = IDS Media Store Plug In.	
<b>Voice Media Store</b>	
<b>Assembly File Name</b>	The name of the plug-in file to be loaded. If the plug-in is not located in the default file path, which is the same folder as the host application, you must also specify the file path.  For this plug-in, use: <code>ASVoiceMediaStore.dll</code>
<b>Media Store URL</b>	The URL used by remoting clients to connect to this media store. The URL must use the following format: <code>gtcp://FullyQualifiedComputerName:29072/Voice.rem.</code>
<b>IDS Media Store Plugin</b>	See <a href="#">IDS Media Store Plugin common configurable components</a> on page 418.
<b>Server Identifier</b>	See <a href="#">Server Identifier common configurable components</a> on page 421.
<b>Application Management Service</b>	See <a href="#">Application Management Service common configurable components</a> on page 413.
<b>Client Connections</b>	See <a href="#">Client connections common configurable components</a> on page 414.
<b>Media Director</b>	See <a href="#">Edit Voice Media Store field descriptions</a> on page 115.
<b>Database</b>	See <a href="#">Edit Voice Media Store field descriptions</a> on page 115.

*Table continues...*



Name	Description
XML Server	See <a href="#">Voice Media Store</a> on page 85.
VDN Group1	See <a href="#">Configuring VDN Groups</a> on page 87.
License Director	See <a href="#">License Director common configurable components</a> on page 419.

## Configuring Simple Messaging Media Store through .ini file

### About this task

To configure Simple Messaging Media Store:

### Procedure

1. In the Windows explorer, navigate to the \Avaya Aura® CC Elite Multichannel \Server\Media Stores\Simple Messaging Media Store directory.
2. Open the `ASSimpleMessagingMediaStore.ini` file for editing.

Use the definitions described in the *ASSimpleMessagingMediaStore.ini file parameter descriptions* table to define your configuration data.

**\* Note:**

Do not change section names or parameter names.

## ASSimpleMessagingMediaStore.ini file parameter descriptions

Name	Description
Startup	
Version	The version of the configuration file. The version information includes values such as major version, minor version, build number, and revision number.
Error Logging	See <a href="#">Error Logging</a> on page 339.
Server Identifier	See <a href="#">Server Identifier common configurable components</a> on page 421.
Globalization Default Culture	The locale that the Simple Messaging Media Store uses when it sends system messages to the agent. If you use the 'en' locale, the messages appear in English. Similarly, 'fr' defaults to French, 'de' to German, 'it' to Italian, 'es' to Spanish, 'es-CO' to

*Table continues...*

Name	Description
	<p>Spanish Colombian, 'pt' to Portuguese (Brazilian), 'ru' to Russian, 'ko' to Korean, 'ja' to Japanese, 'zh-CHT' to Traditional Chinese, and 'zh-CHS' to Simplified Chinese.</p> <p> <b>Note:</b></p> <p>This remaining part of this section contains a list of custom cultures you want to set up for use by Simple Messaging Media Store queues. You can create the custom cultures as per your requirement. Each culture has its own section of configuration details, therefore, the specified culture name must match the section heading.</p>
<b>Culture 1.</b>	<p>A name for the custom culture to be used by one or more Simple Messaging Media Store queues. You can start the custom culture name with the standard .net culture name, for example, 'fr', and end it with something meaningful. In the following example, we have used a further language identifier as the suffix: Culture 1=fr-CA.</p>
<b>fr-CA</b>	
<b>Custom Language</b>	<p>The custom language resource identifier for your custom culture. The identifier has the format xx-XX-xx. You can find the identifier from the custom language resource files, which follow the format, <code>ASResource.&lt;custom culture id&gt;.resx</code>. If your resource file is <code>ASResource.fr-CA-CCEM.resx</code>, you would use <code>Custom Language=fr-CA-CCEM</code>.</p>
<b>Media Director</b>	<p>See <a href="#">Simple Messaging Media Store</a> on page 96.</p>
<b>Database</b>	<p>See <a href="#">Simple Messaging Media Store</a> on page 96.</p>
<b>Simple Messaging Media Store</b>	
<b>Administrator</b>	<p>The email address of the administrator whom the customers must contact. This address is added to Message for Contact Administrator progress message via the %1 placeholder.</p>
<b>Media Store Name</b>	<p>A unique name for the media store. This is the name that the media store passes to Media Director.</p>
<b>Simple Messaging Media Store Remote Factory URI</b>	<p>The URI (Uniform Resource Identifier) of the remote communication object factory on the Simple Messaging Media Store. In this case, the URI is <code>SMMSRemoteFactory.rem</code>.</p>
<b>Media Client Service URL</b>	<p>The URL used by remoting clients to connect to the media store. The URL must use the following format:</p>

*Table continues...*

Name	Description
	channeltype:// fullyqualifiedcomputername:port/uri. If the entry is empty, a default URL is automatically created: gtcp:// fullyqualifiedlocalcomputername:29085/MediaClientSvc.rem.
<b>Simple Messaging Master Plugin URL</b>	The URL for connecting Simple Messaging Plug-in to Simple Messaging Media Store. The URL must use the following format: channeltype:// fullyqualifiedcomputername:port/uri.  If the entry is empty, a default URL is automatically created: gtcp:// fullyqualifiedlocalcomputername:29085/SMMSMasterPlugin.rem
<b>Seconds to Reconnect to Media Director</b>	The time, in seconds, for which the media store waits before trying to reconnect to Media Director after it fails the first time.
<b>Seconds to Keep Simple Messaging Object Alive</b>	The time, in seconds, that indicates how regularly the gateway instructs the Simple Messaging Media Store to keep the message communication object, ASSimpleMessageObj alive.
<b>Seconds to Keep Work Item Alive</b>	The time, in seconds, that indicates how regularly the client application instructs the Simple Messaging Media Store to keep the conversation request work item alive.
<b>Seconds Before Work Item Expires in Media Director Queue</b>	The time, in seconds, for which Media Director holds work items from this media store. If a queued work item exceeds this interval, it is removed from the queue and the media store is notified so it can be resent. If set to 0, work items never expires.
<b>Minutes to Check AutoText Version</b>	The time, in minutes, that indicates how frequently the Simple Messaging Media Store checks the database to see if information in every specified AutoText group (see each gateway queue below) has changed. If the version number of the AutoText group has changed, signifying an update, the updated information is sent to Call Center Elite Multichannel Desktop for the agent to use.
<b>Seconds to Update Queue Progress</b>	The time, in seconds, that indicates how frequently the media store communicates information about the queue's status and how many work items in the queue are in the established, queued or pending state. The minimum is 10 seconds, the maximum is 3600.

*Table continues...*

Name	Description
<b>Autorestart If No Queued Items</b>	If a critical parameter for this media store is changed using Call Center Elite Multichannel Control Panel and Autorestart and No Queued Items is set to True, the media store restarts (update) immediately when there are no queued or delivered items in the Media Director. If set to False, you must restart the media store manually to activate critical parameter changes.
<b>Queues for Media Gateway</b>	A list of queues that you want to set up within Simple Messaging Media Store to receive simple message conversation requests from Call Center Elite Multichannel media gateways. You can create the queues as per the requirement. Each queue has its own section of configuration details, therefore, the specified queue name must match the section heading.
<b>Queue 1</b>	A user-defined name for a media gateway queue. For example: Queue 1=Sales
<b>Application Management Service</b>	See <a href="#">Application Management Service common configurable components</a> on page 413.
<b>Plugin Assembly List</b>	This list of all loadable generic plug-ins. Each entry has the format "Friendly name=Plug-in section name". The plug-in section name points to (and is the same as) the section in the file that contains configuration data for that plug-in. For example: Master Plugin = Master Plugin IDS Plugin = IDS Media Store Plugin.
<b>Master Plugin</b>	This mandatory plug-in that acts as a communication channel for all other plug-ins. For example, IDS Media Store Plugin.
<b>Plugin ID</b>	An ID that is automatically created by the plug-in when the plug-in runs for the first time. Leave blank.
<b>Enable Error Logging</b>	A setting that allows you to write plug-in specific error information to the application's error log files. True=enabled, False=disabled.
<b>Assembly Log Name</b>	The name used for error logging to indicate the specific assembly. For this plug-in, use: Simple Messaging Master Plugin.
<b>Assembly File Name</b>	The name of the plug-in file to be loaded. If the plug-in is not located in the default file path (the same folder as the host application), also specify the file path.

*Table continues...*

Name	Description
	For this plug-in, use: ASSimpleMessagingMasterPlugin.dll.
<b>IDS Media Store Plugin</b>	See <a href="#">IDS Media Store Plugin common configurable components</a> on page 418.
<b>AS Contact Database</b>	See <a href="#">Simple Messaging Media Store</a> on page 96.
<b>Sales</b>	
<b>Queue Status</b>	See <a href="#">Simple Messaging Media Store</a> on page 96.
<b>Queue Privacy</b>	See <a href="#">Simple Messaging Media Store</a> on page 96.
<b>Media Director Queue</b>	See <a href="#">Simple Messaging Media Store</a> on page 96.
<b>Program ID</b>	See <a href="#">Simple Messaging Media Store</a> on page 96.
<b>Request Validation Function</b>	See <a href="#">Simple Messaging Media Store</a> on page 96.
<b>Culture</b>	<p>See <a href="#">Simple Messaging Media Store</a> on page 96.</p> <p>What language is used to send progress messages to your customers is controlled by the locales defined within your simple messaging applications. Those applications are given a locale priority ranking. If a culture is not defined in the highest priority application, the locale is sought from the next application in the rank.</p> <p>The order of precedence is:</p> <ul style="list-style-type: none"> <li>• The culture defined within the web chat browser (only if running Web Chat Gateway).</li> <li>• The culture defined within the gateway configuration.</li> <li>• The culture defined within the Simple Messaging Media Store configuration for the specific queue.</li> <li>• The culture defined within Simple Messaging Media Store's configuration for the media store itself.</li> </ul> <p><b>* Note:</b></p> <ul style="list-style-type: none"> <li>• The media store always uses this locale to send system messages to the agent.</li> <li>• The culture is defined within the operating system of the system running Simple Messaging Media Store.</li> </ul>
<b>Seconds Before Offline Interaction Expires</b>	See <a href="#">Simple Messaging Media Store</a> on page 96.
<b>Offline Interaction Autoclose</b>	See <a href="#">Simple Messaging Media Store</a> on page 96.
<b>Suppress Going Backwards Progress Messages</b>	See <a href="#">Simple Messaging Media Store</a> on page 96.

*Table continues...*

Name	Description
<p><b>Number of Next Schedules to Display</b></p>	<p>If a customer makes contact outside queue hours, the value you enter here controls how many upcoming open-hour schedules are presented to the customer. For example, if you enter 3, the open and close times for the next three schedules are displayed, along with the out-of-hours progress message.</p> <p><b>* Note:</b></p> <p>The system displays more schedules if the number of Days to Display Next Schedules includes more schedules.</p> <p>Default is 7.</p>
<p><b>Days to Display Next Schedules</b></p>	<p>If a customer makes contact outside queue hours, the value you enter here controls how many days of open-hour schedules are presented to the customer. For example, if you enter 5, the open and close times for all schedules that run over the next five days are displayed.</p> <p><b>* Note:</b></p> <p>The system displays more schedules if the Number of Next Schedules to Display specifies more than there are within Days to Display Next Schedules.</p> <p>Default is 7.</p>

## Configuring AOL-ICQ Instant Messenger Gateway through .ini file

### About this task

To configure AOL-ICQ Instant Messenger Gateway:

### Procedure

1. In the Windows explorer, navigate to the `\Avaya Aura® CC Elite Multichannel \Server\Media Gateways\AOL-ICQ Instant Messenger Gateway` directory.
2. Open the `ASAIMGateway.ini` file for editing.

Use the definitions described in the *ASAIMGateway.ini file parameter descriptions* table to define your configuration data.

**\* Note:**

Do not change section names or parameter names.

---

## ASAIMGateway.ini file parameter descriptions

Name	Description
Startup	
Version	The version of this configuration file. Version information is made up of the following values: Major and minor version, build number, and revision number.
Server Identifier	See <a href="#">Server Identifier common configurable components</a> on page 421.
Error Logging	See <a href="#">Error Logging</a> on page 339.
Gateway	See <a href="#">Configuring an AOL-ICQ Instant Messenger Gateway</a> on page 175.
Simple Messaging Media Store	See <a href="#">Simple Messaging Media Store common configurable components</a> on page 422.
Remote Services	See <a href="#">Configuring an AOL-ICQ Instant Messenger Gateway</a> on page 175.
Culture	See <a href="#">Configuring an AOL-ICQ Instant Messenger Gateway</a> on page 175.
Progress Messages	See <a href="#">Gateway Progress Messages common configurable components</a> on page 417.
Application Management Service	See <a href="#">Application Management Service common configurable components</a> on page 413.

---

## Configuring MSN Instant Messenger through .ini file

### About this task

To configure MSN Instant Messenger:

### Procedure

1. In the Windows explorer, navigate to the `\Avaya Aura® CC Elite Multichannel \Server\Media Gateways\MSN Messenger Gateway` directory.
2. Open the `ASMSnMessengerGateway.ini` file for editing.

Use the definitions described in the *ASMSnMessengerGateway.ini file parameter descriptions* table to define your configuration data.

**\* Note:**

Do not change section names or parameter names.

---

## ASMSnMessengerGateway.ini file parameter descriptions

Name	Description
<b>Version</b>	The version of this configuration file. Version information is made up of the following values: Major and minor version, build number, and revision number.
	See <a href="#">Server Identifier common configurable components</a> on page 421.
	See <a href="#">Error Logging</a> on page 339.
	See <a href="#">Configuring an MSN Messenger Gateway</a> on page 178.
	See <a href="#">Simple Messaging Media Store common configurable components</a> on page 422.
	See <a href="#">Configuring an MSN Messenger Gateway</a> on page 178.
	See <a href="#">Configuring an MSN Messenger Gateway</a> on page 178.
	See <a href="#">Gateway Progress Messages common configurable components</a> on page 417.
	See <a href="#">Application Management Service common configurable components</a> on page 413.
	See <a href="#">Configuring an MSN Messenger Gateway</a> on page 178.

---

## Configuring Short Message Service Gateway through .ini file

### About this task

To configure Short Message Service Gateway:

### Procedure

1. In the Windows explorer, navigate to the `\Avaya Aura® CC Elite Multichannel \Server\Media Gateways\SMS Gateway` directory.
2. Open the `ASSmsGateway.ini` file for editing.

Use the definitions described in the *ASSmsGateway.ini file parameter descriptions* table to define your configuration data.



**\* Note:**

Do not change section names or parameter names.

## ASSmsGateway.ini file parameter descriptions

Name	Description
Startup	
Version	The version of this configuration file. Version information is made up of the following values: Major and minor version, build number, and revision number.
Server Identifier	See <a href="#">Server Identifier common configurable components</a> on page 421.
Error Logging	See <a href="#">Error Logging</a> on page 339.
Gateway	See <a href="#">Configuring Short Message Service Gateway</a> on page 181.
Simple Messaging Media Store	See <a href="#">Simple Messaging Media Store common configurable components</a> on page 422.
Remote Services	See <a href="#">Configuring Short Message Service Gateway</a> on page 181.
Culture	See <a href="#">Configuring Short Message Service Gateway</a> on page 181.
Progress Messages	See <a href="#">Gateway Progress Messages common configurable components</a> on page 417.
Application Management Service	See <a href="#">Application Management Service common configurable components</a> on page 413.

## Configuring Web Chat Gateway through .ini file

### About this task

To configure Web Chat Gateway:

### Procedure

1. In the Windows explorer, navigate to the `\Avaya Aura® CC Elite Multichannel \Server\Media Gateways\Web Chat Gateway` directory.
2. Open the `ASWebChatGateway.ini` file for editing.

Use the definitions described in the *ASWebChatGateway.ini file parameter descriptions* table to define your configuration data.

**\* Note:**

Do not change section names or parameter names.

## ASWebChatGateway.ini file parameter descriptions

Name	Description
Startup	
Version	The version of this configuration file. Version information is made up of the following values: Major and minor version, build number, and revision number.
Server Identifier	See <a href="#">Server Identifier common configurable components</a> on page 421.
Error Logging	See <a href="#">Error Logging</a> on page 339.
Gateway	See <a href="#">Configuring the Web Chat Gateway</a> on page 166.
Simple Messaging Media Store	See <a href="#">Simple Messaging Media Store common configurable components</a> on page 422.
Remote Services	See <a href="#">Configuring the Web Chat Gateway</a> on page 166.
Culture	See <a href="#">Configuring the Web Chat Gateway</a> on page 166.
Progress Messages	See <a href="#">Gateway Progress Messages common configurable components</a> on page 417.
Application Management Service	See <a href="#">Application Management Service common configurable components</a> on page 413.

## Configuring Communicator Gateway through .ini file

### About this task

To configure Communicator Gateway:

### Procedure

1. In the Windows explorer, navigate to the `\Avaya Aura® CC Elite Multichannel \Server\Media Gateways\Communicator Gateway` directory.
2. Open the `ASCommunicatorGateway.ini` file for editing.

Use the definitions described in the *ASCommunicatorGateway.ini file parameter descriptions* table to define your configuration data.

**\* Note:**

Do not change section names or parameter names.

## ASCommunicatorGateway.ini file parameter descriptions

Name	Description
Startup	
Version	The version of this configuration file. Version information is made up of the following values: Major and minor version, build number, and revision number.
Server Identifier	See <a href="#">Server Identifier common configurable components</a> on page 421.
Error Logging	See <a href="#">Error Logging</a> on page 339.
Gateway	See <a href="#">Configuring a Communicator Gateway</a> on page 185.
Simple Messaging Media Store	See <a href="#">Simple Messaging Media Store common configurable components</a> on page 422.
Remote Services	See <a href="#">Configuring a Communicator Gateway</a> on page 185.
Culture	See <a href="#">Configuring a Communicator Gateway</a> on page 185.
Progress Messages	See <a href="#">Gateway Progress Messages common configurable components</a> on page 417.
Application Management Service	See <a href="#">Application Management Service common configurable components</a> on page 413.

## Configuring GTalk Gateway through .ini file

### About this task

To configure GTalk Gateway:

### Procedure

1. In the Windows explorer, navigate to the `\Avaya Aura CC Elite Multichannel \Server\Media Gateways\XMPP Gateway` directory.
2. Open the `ASXmppGateway.ini` file for editing.

Use the definitions described in the *ASXmppGateway.ini file parameter descriptions* to define your configuration data.

**\* Note:**

Do not change section names or parameter names.

## ASXmppGateway.ini file parameter descriptions

Name	Description
<b>Version</b>	The version of this configuration file. Version information is made up of the following values: Major and minor version, build number, and revision number.
<b>Server Identifier</b>	See <a href="#">Server Identifier common configurable components</a> on page 421.
<b>Error Logging</b>	See <a href="#">Error Logging</a> on page 339.
<b>Gateway</b>	See <a href="#">Configuring an XMPP or a GTalk Gateway</a> on page 192.
<b>Simple Messaging Media Store</b>	See <a href="#">Simple Messaging Media Store common configurable components</a> on page 422.
<b>Remote Services</b>	See <a href="#">Configuring an XMPP or a GTalk Gateway</a> on page 192.
<b>Culture</b>	See <a href="#">Configuring an XMPP or a GTalk Gateway</a> on page 192.
<b>Progress Messages</b>	See <a href="#">Gateway Progress Messages common configurable components</a> on page 417.
<b>Application Management Service</b>	See <a href="#">Application Management Service common configurable components</a> on page 413.

# Appendix D: Common Configurable Components

---

## Application Management Service common configurable components

Name	Description
<b>Multicast IP</b>	The IP address that is used for multicasting between applications. When an application starts, the application joins this multicast address and receives packet information from the Application Management Director. The default is 239.29.9.67.
<b>Multicast Port</b>	The port number that is used for multicasting between applications. The default is 29075.
<b>Enable Multicast</b>	A value that determines if multicasting is used to locate the Application Management Director.
<b>Application Management Director URL List</b>	If multicasting is disabled, the URLs are used to find the Application Management Directors set up in your contact center. Items are separated by commas and follow the format: IP address:port number, IP address:port number.
<b>Management Object URL</b>	The URL used by Call Center Elite Multichannel Control Panel to connect to the remoting management object. The URL must use the following format:  channeltype://fullyqualifiedcomputername:port/url.  If the entry is empty, a default URL is automatically created.

## Client connections common configurable components

Name	Description
<b>IP Address</b>	The local IP address for accepting incoming client connections.
<b>IP Port</b>	The local IP port for accepting incoming client connections.
<b>Allow Multicast</b>	A value that determines whether multicasting of the connection information is enabled or not. True=enabled, False=disabled.
<b>Enable Trace</b>	A value that determines if information is logged to the log file. True=enabled, False=disabled.
<b>Broadcast Interval In Seconds</b>	How often, in seconds, is the connection information multicasted.
<b>Multicast IP</b>	The IP address that is used for multicasting the connection information. The default is 239.29.9.67.
<b>Multicast Port</b>	The port number that is used for multicasting the connection information.
<b>Receive Buffer Length</b>	The buffer size for incoming messages. The default is 20000.

## Contact database common configurable components

Name	Description
<b>Server name</b>	The name of the server on which the database is located.
<b>Database name</b>	The name of the database. This is automatically named ASContact when the database script is run.
<b>User name</b>	The user name required to gain access to the database. This is automatically named ASContact when the database script is run.
<b>Password</b>	The password associated with the user name. The default password is CCEUser0 before encryption. For more information, see <i>Installing Avaya Aura® Call Center Elite Multichannel</i> .
<b>Connection string</b>	An ADO connection string built from the previous four parameters and used for database connectivity. This string is empty until the service is run the first time, at which point a default connection string with the following format is automatically created: Data

*Table continues...*

Name	Description
	<p>Source=LocalComputerName;Initial Catalog=ASContact;User ID=ASContact;Password=CCEUser0;</p> <p>If you modify any of the four database parameters, the change is automatically viewed in the connection string. When you save the changes, the entire string is encrypted automatically into the configuration file.</p> <p> <b>Note:</b></p> <p>If you modify the connection string through the configuration file of media store and add additional 'non-standard' elements, you can view the string in Call Center Elite Multichannel Control Panel but you cannot edit it. If you try to edit the string, it automatically reverts to its default structure and values.</p>

## Error Logging common configurable components

Name	Description
Level	<p>The value that determines what level of error detail is saved in the error log:</p> <ul style="list-style-type: none"> <li>• 0=No error logging takes place.</li> <li>• 1=Logs fatal, major, minor and trace information.</li> <li>• 2=Logs fatal, major and minor errors.</li> <li>• 4=Logs fatal and major errors.</li> <li>• 8=Logs fatal errors only.</li> </ul> <p>Moreover, there is another error log level available. This error log enables you to create log files that do not override each other when the maximum log file size limit is reached. This logging level is designed for diagnostic purposes only and can be achieved by adding 128 to one of the logging level values mentioned above. For example, if you type 129 in the text box, new error log files are created for this application that contain fatal, major, minor and trace information.</p>
Path	<p>The directory path for saving error log files. By default, this parameter is blank, which automatically sets the path to the application current working</p>

*Table continues...*

Name	Description
	folder, which is the same folder as the application executable.
<b>Size (KB)</b>	<p>The maximum amount of information, in KB, that is stored in an error log file before the error log is archived and a new file is created. The default is 1000. The minimum value that you can set is 100.</p> <p> <b>Note:</b></p> <p>The archive stores only one log file. If a second error log reaches the specified maximum size, it overrides the previously archived file. If the diagnostic testing error log level is selected in Level, a new file with a new name is created when the maximum log file size limit exceeds. The level is achieved by adding 128 to any one of the other error log values.</p>
<b>Extension</b>	The extension of error log files for this application. Extension refers to part of the file name, usually the name of the application and the file type extension, such as .log. The application automatically precedes the default extension with the day of the week such as, Mon, Tue, when the application creates the error logs.

## Gateway Details common configurable components

Name	Description
<b>Server instance friendly name</b>	Any name you want to display for this application within Call Center Elite Multichannel Control Panel.
<b>Gateway name</b>	A unique name used by Simple Messaging Media Store to identify this instance of Web Chat Gateway.
<b>Culture</b>	The locale used by the gateway to define character sets, date and time formats, currency formats etc. If you use an 'en' locale, the Language parameter defaults to English, likewise 'fr' defaults to French, 'de' to German, 'it' to Italian, 'es' to Spanish, 'es-CO' to Spanish Colombian, 'pt' to Portuguese (Brazilian), 'ru' to Russian, 'ko' to Korean, 'ja' to Japanese, 'zh-CHT' to Traditional Chinese, and 'zh-CHS' Simplified Chinese. This does not affect the language of the work item conversation.

*Table continues...*



Name	Description
<b>Seconds to reconnect to Simple Messaging Media Store</b>	How often, in seconds, Web Chat gateway attempts to reconnect to the Simple Messaging Media Store. The default value is 60 seconds.
<b>Minutes to close idle session</b>	The acceptable length of time, in minutes, a conversation can be idle before it is closed. The default value is 3 minutes.
<b>Request validation function</b>	The type of customer ID validation. This value represents a stored function in the SQL Server database. Values are IsMatchExactAddress or IsMatchOnEmailAddress. If no validation is specified or the specified validation does not exist on the SQL Server, IsMatchExactAddress is automatically used.

---

## Gateway Proxy Settings for common configurable components

If you enable authorization for the Web Chat Gateway, select the Basic option for MSN Messenger Gateway, AOL-ICQ Instant Messenger Gateway and Short Message Service Gateway, and Integrated for Web Chat Gateway.

**\* Note:**

Web Chat Gateway cannot connect to the remote service using proxy server if authorization is disabled on the gateway and required on the proxy.

---

## Gateway Progress Messages common configurable components

This section contains information about customizing the messages sent from Web Chat Gateway to users. You can use any of the languages supported by Call Center Elite Multichannel.

Name	Description
<b>Message for SMMS Server Offline</b>	The message sent when Simple Messaging Media Store is not available. For example: Message for SMMS Server Offline=Sorry, the service is temporarily offline due to a technical problem. Please try again later.
<b>Message for Generic Problem Starting Session</b>	The message sent when there is a problem starting the conversation. For example: Message for Generic

*Table continues...*

Name	Description
	Problem Starting Session=A technical problem prevents us starting a conversation now. Please try again later.

## IDS Media Store Plugin common configurable components

Name	Description
<b>Plugin ID</b>	An ID automatically created by the plug-in when it first runs. Leave blank.
<b>Assembly File Name</b>	The name of the plug-in file to be loaded. If the plug-in is not located in the default file path (the same folder as the media store application), also specify the file path. For this plug-in, use: ASIDSMediaStorePlugin.dll
<b>Server Instance Auto Connect Type</b>	If this value is the same as the Server Instance Type specified within Interaction Data Server - Multimedia's configuration, a connection with the Interaction Data Server - Multimedia is automatically established when this application starts up. Typically, you would leave the default value, which is the well-known GUID of Interaction Data Server - Multimedia.   <b>Note:</b> The automatic connection also relies on multicasting being enabled and the Multicast IP and Multicast Port being the same as those specified within Interaction Data Server - Multimedia configuration.
<b>Local Address</b>	If you leave this parameter blank, the machine's local address is automatically used to establish a connection with Interaction Data Server - Multimedia. If the machine has more than one network card, you can specify the one you want to use.
<b>Multicast Group Address</b>	The IP address that is used for multicasting between applications. The default is 239.29.9.67.
<b>Multicast Group Port</b>	The port number that is used for multicasting between applications. The default is 29078.
<b>Receive Buffer Length</b>	The maximum number of events that can be saved in the IDS Media Store Plug-in's internal queue. If the connection between the plug-in and the Interaction Data Server - Multimedia is working, the queue is usually empty. If the connection is lost, events sent

*Table continues...*

Name	Description
	to the plug-in are retained until the connection is re-established. The default is 20000.
<b>Enable Trace</b>	A setting that allows you to send application error information to the debug window. True=enabled, False=disabled.
<b>Enable Error Logging</b>	A setting that allows you to write plug-in specific error information to the application's error log files. True=enabled, False=disabled.

---

## Media Director common configurable components

Name	Description
<b>Media Director</b>	<p>A drop-down list box that allows you to easily select a running Media Director for the media store to connect to. Once selected, the service's details automatically appear in the URL, IP, Port, Channel type and URI fields. To view the Media Director details inside Call Center Elite Multichannel Control Panel, click the Media Director link.</p> <p>The URL must follow the following format:</p> <pre>channeltype:// fullyqualifiedcomputername:port/uri.</pre> <p>If the entry is empty, a default URL is automatically created:</p> <pre>gtcp://fullyqualifiedlocalcomputername: 29087/RemoteFactory.rem</pre>

---

## License Director common configurable components

Name	Description
<b>Primary IP</b>	The IP address of the primary License Director through which this application request and release licenses.
<b>Primary port</b>	The port number of the primary License Director. The default is 29095.

*Table continues...*

Name	Description
Secondary IP	The IP address of the secondary License Director through which this application request and release licenses.
Secondary port	The port number of the secondary License Director. The default is 29095.

---

## Media Store common configurable components

Name	Description
Media Store	<p>A drop-down list box that allows you to easily select a running Simple Messaging Media Store for the gateway to connect to. Once selected, the service's details automatically appear in the URL, IP, Port, Channel type and URI fields. To view the Media Store details inside Call Center Elite Multichannel Control Panel, click the Media Store link.</p> <p>The URL must follow the following format:</p> <pre>channeltype:// fullyqualifiedcomputername:port/uri.</pre> <p>If the entry is empty, a default URL is automatically created:</p> <pre>gtcp://fullyqualifiedlocalcomputername: 29085/SMMSRemoteFactory.rem.</pre>

---

## Media Store Database common configurable components

Name	Description
Server name	The name of the server on which the database is located.
Database name	The name of the database. This is automatically named ASMediaStore when the database script is run.
User name	The user name required to gain access to the database. This is automatically named ASMediaStore when the database script is run.

*Table continues...*

Name	Description
Password	The password associated with the above user name. By default this is CCEUser0 before encryption. For more information, see <i>Installing Avaya Aura® Call Center Elite Multichannel</i> .
Connection string	<p>An ADO connection string built from the previous four parameters and used for database connectivity. This string is empty until the service is run the first time, at which point a default connection string with the following format is automatically created: Data Source=LocalComputerName;Initial Catalog=ASMediaStore;UserID=ASMediaStore;Password=CCEUser0;</p> <p>If you modify any of the four database parameters, the change is automatically viewed in the connection string. When you save (commit) the changes, the entire string is automatically encrypted into the configuration file.</p> <p><b>* Note:</b></p> <p>If you modify the connection string through the configuration file of media store and add additional 'non-standard' elements, you can view the string in Control Panel but you cannot edit it. If you try to edit the string, it automatically reverts to its default structure and values.</p>

---

## Server Identifier common configurable components

Name	Description
Server Instance Friendly Name	Any name you want to display for this application within Call Center Elite Multichannel Control Panel. If you leave this parameter blank, the application node text automatically takes the format <application name>@<server name>.
Server Instance ID	A unique identifier for the server application, which is created automatically when it runs for the first time.
Server Instance Type	An ID used by other applications to determine what type of component they are communicating with.

## Service Plug-in Host common configurable components

Name	Description
<b>Service Display Name</b>	The text that displays for this service under the Name column of the Microsoft Windows Services screen.
<b>Service Command Line</b>	Leave this parameter blank. By default, Service Host Plug-in takes its configuration data from the same working folder that contains the application executable.
<b>Service Description</b>	The text that displays for this service under the Description column of the Microsoft Windows Services screen.
<b>Service Startup State</b>	A value that determines the state of the service when it is installed. 0=Disabled, 1=Manual, 2=Automatic.

## Simple Messaging Media Store common configurable components

Name	Description
<b>Simple Messaging Media Store URL</b>	The URL for connecting to the Simple Messaging Media Store. If this parameter is empty, the next three parameters are used to form the URL.
<b>Simple Messaging Media Store IP</b>	The IP address of the Simple Messaging Media Store.
<b>Simple Messaging Media Store Port</b>	The port number of the Simple Messaging Media Store. The default value is 29085.
<b>Simple Messaging Media Store Remote Factory URI</b>	The URI (Uniform Resource Identifier) of the remote communication object factory on the Simple Messaging Media Store. In this case, the URI is <code>SMMSRemoteFactory.rem</code> .

## XML Server common configurable components

Name	Description
<b>Primary IP</b>	The IP address of the primary XML Server.

*Table continues...*

Name	Description
<b>Primary port</b>	The IP port number of the primary XML Server. By connecting to this port, clients get a list of currently configured XML interfaces (IP address/port number combinations) they can connect to for service. The naming service default port is 29096.
<b>Secondary IP</b>	The IP address of the secondary XML Server.
<b>Secondary port</b>	The IP port number of the secondary XML Server.
<b>Primary link</b>	The name of the primary link this application uses to connect to the Telephony Server and switch.
<b>Secondary link</b>	The name of the secondary link this application uses to connect to the Telephony Server and switch.

# Index

## A

Abandoned Call Assistant .....	90
ACS database .....	265
adding user .....	273
add schedule .....	<a href="#">105</a> , <a href="#">122</a> , <a href="#">149</a> , <a href="#">199</a>
administration .....	291
Advanced .....	256
AgentID .....	<a href="#">108</a> , <a href="#">125</a> , <a href="#">151</a> , <a href="#">202</a>
AgentName .....	<a href="#">108</a> , <a href="#">125</a> , <a href="#">151</a> , <a href="#">202</a>
agents .....	<a href="#">32</a> , <a href="#">243</a>
Allow VDN Override .....	256
Application Management Service .....	<a href="#">21</a> , <a href="#">41</a> , <a href="#">102</a>
Application Name /z .....	<a href="#">280</a>
applications .....	<a href="#">34</a>
architecture .....	<a href="#">62</a>
ASContact .....	<a href="#">233</a>
ASContact Contacts table .....	<a href="#">222</a>
ASContact database .....	<a href="#">229</a> , <a href="#">235</a> , <a href="#">236</a>
ASContact Database .....	<a href="#">222</a> , <a href="#">225</a> , <a href="#">228</a> , <a href="#">236</a>
ASMediaStore Database .....	<a href="#">21</a>
ASMediaStore database .....	<a href="#">110</a> , <a href="#">114</a> , <a href="#">127</a> , <a href="#">131</a> , <a href="#">153</a> , <a href="#">157</a> , <a href="#">204</a> , <a href="#">208</a> , <a href="#">215</a>
AS Script Master file .....	<a href="#">279</a>
assigning user .....	<a href="#">274</a>
assign schedule .....	<a href="#">114</a> , <a href="#">131</a> , <a href="#">157</a> , <a href="#">208</a>
AssociatedData .....	<a href="#">225</a>
Attendant Vectoring .....	<a href="#">256</a>
Auto Shrink .....	<a href="#">28</a>
AutoText group .....	<a href="#">107</a> , <a href="#">124</a> , <a href="#">150</a> , <a href="#">201</a>
AutoText Plug-in .....	<a href="#">108</a> , <a href="#">125</a> , <a href="#">151</a> , <a href="#">202</a>
Avaya Communication Manager Algorithms .....	<a href="#">45</a>

## B

backup .....	<a href="#">97</a> , <a href="#">266</a>
Break .....	<a href="#">108</a> , <a href="#">125</a> , <a href="#">151</a> , <a href="#">202</a>
BuildPhoneLookUp .....	<a href="#">222</a> , <a href="#">232</a>

## C

CCE Queue Data report .....	<a href="#">332</a>
client .....	<a href="#">263</a>
client connections .....	<a href="#">308</a>
Client Connections .....	<a href="#">267</a>
CM Admin	
managing services	
edit medial store	
application management service .....	<a href="#">413</a>
client connections .....	<a href="#">414</a>
contact database .....	<a href="#">414</a>
gateway details .....	<a href="#">416</a>
gateway proxy settings .....	<a href="#">417</a>

IDS media store plug-in .....	<a href="#">418</a>
license director .....	<a href="#">419</a>
media director .....	<a href="#">419</a>
media store .....	<a href="#">420</a>
media store database .....	<a href="#">420</a>
server identifier .....	<a href="#">421</a>
service plug-in host .....	<a href="#">422</a>
simple messaging media store .....	<a href="#">422</a>
XML server .....	<a href="#">422</a>
troubleshooting .....	<a href="#">333</a>
column display .....	<a href="#">236</a>
ColumnTypeld .....	<a href="#">236</a>
Command Processing /d .....	<a href="#">280</a>
Communicator Gateway .....	<a href="#">70</a>
COMPUTERNAME .....	<a href="#">286</a>
concurrent .....	<a href="#">35</a>
configuration .....	<a href="#">41</a> , <a href="#">263</a>
Configuration .....	<a href="#">283</a>
Configuration Client .....	<a href="#">75</a> , <a href="#">287</a>
Configuration Filter /a .....	<a href="#">280</a>
configuration manager .....	<a href="#">267</a>
Configuration Server Manager .....	<a href="#">267</a>
configure .....	<a href="#">243</a> , <a href="#">339</a>
configure file groups .....	<a href="#">27</a>
configure tmp database .....	<a href="#">27</a>
configuring .....	<a href="#">55</a>
configuring Interaction Data Server - View .....	<a href="#">303</a>
configuring services .....	<a href="#">53</a> , <a href="#">100</a> , <a href="#">102</a>
contact gateway .....	<a href="#">220</a>
Contact groups .....	<a href="#">234</a>
contact overview .....	<a href="#">219</a>
Contacts .....	<a href="#">235</a>
Contacts_GW .....	<a href="#">228</a> , <a href="#">231</a>
Context menu .....	<a href="#">249</a> , <a href="#">256</a> , <a href="#">260</a>
control panel .....	<a href="#">23</a> , <a href="#">374</a>
conversation and customer .....	<a href="#">320</a>
COR .....	<a href="#">256</a>
create program .....	<a href="#">114</a> , <a href="#">131</a> , <a href="#">157</a> , <a href="#">208</a>
CreateUpperPhoneLookUp .....	<a href="#">231</a>
CWD .....	<a href="#">286</a>

## D

database .....	<a href="#">39</a> , <a href="#">263</a> , <a href="#">273</a>
database configuration .....	<a href="#">226</a>
Database Management .....	<a href="#">233</a>
DATE .....	<a href="#">286</a>
default file group .....	<a href="#">29</a>
delete databases .....	<a href="#">97</a> , <a href="#">266</a>
DeleteExtraData .....	<a href="#">66</a>
deploy .....	<a href="#">189</a>
deployment .....	<a href="#">23</a>
Deployment .....	<a href="#">23</a>



Description ..... [260](#)  
 desktop ..... [263](#)  
 developing client applications ..... [308](#)  
 Directory ..... [234](#)  
 Dump working set (/DWS) ..... [280](#)

**E**

email ..... [60](#)  
 Email Media Store ..... [75](#), [134](#), [215](#)  
 enumeration values ..... [322](#)  
 Environment ..... [108](#), [125](#), [151](#), [202](#)  
 error ..... [41](#)  
 error logging ..... [337](#), [339](#)  
     classic logging ..... [335](#)  
     custom log level ..... [337](#)  
     logging levels ..... [336](#)  
     ttrace config ..... [338](#)  
     ttrace console ..... [338](#)  
     ttrace log2zip ..... [339](#)  
     ttrace server ..... [337](#)  
 error messages ..... [36](#)  
 Extension ..... [256](#)  
 external server ..... [227](#)

**F**

File Name /f ..... [280](#)  
 FindContactsFromAddress ..... [227](#), [231](#)  
 FindUpdatedPhoneColumns ..... [231](#)  
 format ..... [282](#)  
 FormatPhoneLookUp ..... [231](#)

**G**

gateway view ..... [228](#)  
 General ..... [233](#), [249](#), [256](#), [260](#)  
 GetExtraData ..... [65](#)  
 GetMSPermissionsForContact ..... [223](#)  
 GetQueueData ..... [67](#)  
 GetWorkItemProperties ..... [67](#)  
 groups ..... [220](#)

**H**

historical reporting data ..... [318](#)  
 History Plug-in ..... [90](#)

**I**

ICQ Instant Messenger messages ..... [70](#)  
 identification and searches ..... [227](#)  
 Include /i ..... [280](#)  
 Include file errors /j ..... [280](#)  
 Initialize ..... [64](#)  
 InteractionData ..... [108](#), [125](#), [151](#), [202](#)

InteractionID ..... [64](#)  
 InvokeRef ..... [65](#)  
 IPADDRESS ..... [286](#)  
 IsMatch ..... [232](#)

**K**

Key ..... [65–67](#)

**L**

language support ..... [264](#)  
 license administration ..... [38](#)  
 license director ..... [34](#), [36–38](#)  
 License Director ..... [35](#), [100](#)  
 licensing ..... [36](#), [41](#), [46](#)  
 List view ..... [249](#), [256](#), [260](#)  
 LoggedInUser ..... [108](#), [125](#), [151](#), [202](#)  
 Logging State /t ..... [280](#)  
 LongDate ..... [108](#), [125](#), [151](#), [202](#)  
 LongTime ..... [108](#), [125](#), [151](#), [202](#)

**M**

MachineName ..... [108](#), [125](#), [151](#), [202](#)  
 Mailbox Check Interval ..... [75](#)  
 MaintainPhoneLookUp ..... [231](#), [232](#)  
 management ..... [25](#)  
 Management ..... [23](#)  
 management plug-in ..... [23](#)  
 manage templates ..... [77](#)  
 managing databases ..... [23](#), [25](#)  
 managing services  
     AOL\_ICQ instant messenger gateway  
         configure ..... [166](#)  
 Measured ..... [256](#)  
 media director ..... [44](#), [103](#)  
 Media Director ..... [75](#), [84](#)  
 Media Proxy ..... [75](#)  
 media store database ..... [213](#)  
 MediastoreEntityId ..... [223](#)  
 media store permissions ..... [223](#)  
 Meet me Conferencing ..... [256](#)  
 message ..... [41](#)  
 miscellaneous capabilities ..... [320](#)  
 MSN Messenger Gateway ..... [70](#)  
 Multimedia ..... [298](#)  
 multimedia CMS plug-in ..... [323](#)  
 multimedia work items ..... [217](#)

**N**

Name ..... [256](#)  
 NextRecordSetIndex ..... [65](#), [67](#)  
 Number ..... [260](#)

## Index

### O

operation .....	<a href="#">278</a>
outbound .....	<a href="#">52, 61</a>
outbound programs .....	<a href="#">217</a>
outbound work items .....	<a href="#">60</a>
Overall rating .....	<a href="#">226</a>
overview .....	<a href="#">41</a>

### P

Password Encryption .....	<a href="#">280</a>
Permissions .....	<a href="#">238</a>
PermissionsRank .....	<a href="#">223</a>
phonelookup .....	<a href="#">222</a>
PhoneLookUp .....	<a href="#">222, 231</a>
PreferredAgentID .....	<a href="#">65</a>
PreferredAgentOnly .....	<a href="#">65</a>
Preview Contact Media Store .....	<a href="#">84, 215</a>
Primary Server	
Name /s	
Port /p .....	<a href="#">280</a>
ProgramData .....	<a href="#">108, 125, 151, 202</a>
ProgramId .....	<a href="#">223</a>

### Q

quotation marks .....	<a href="#">287</a>
-----------------------	---------------------

### R

rating .....	<a href="#">226</a>
real .....	<a href="#">50</a>
real-life example .....	<a href="#">277</a>
real time reporting data for clients .....	<a href="#">311</a>
reports from Avaya CMS .....	<a href="#">322</a>
repository .....	<a href="#">34</a>
restore .....	<a href="#">97, 266</a>
retrieve .....	<a href="#">189</a>
routing .....	<a href="#">39</a>
rules for use .....	<a href="#">288</a>

### S

Save method .....	<a href="#">288</a>
search capability .....	<a href="#">221</a>
Search target fields .....	<a href="#">235</a>
secondary file group .....	<a href="#">29</a>
Secondary Server	
Name /s2	
Port /p2 .....	<a href="#">280</a>
server .....	<a href="#">263</a>
Server .....	<a href="#">267</a>
ServerInstanceId .....	<a href="#">223</a>
ServerInstanceType .....	<a href="#">223</a>
servers distribution .....	<a href="#">37</a>

SetCustomerData .....	<a href="#">64</a>
SetExtraData .....	<a href="#">66</a>
ShortDate .....	<a href="#">108, 125, 151, 202</a>
Short Message Service Gateway .....	<a href="#">70</a>
ShortTime .....	<a href="#">108, 125, 151, 202</a>
simple messaging .....	<a href="#">217</a>
Simple Messaging Media Store .....	<a href="#">215</a>
Skill	
Number .....	
Name .....	
Extension .....	
Type .....	<a href="#">249</a>
Skill1 .....	<a href="#">256</a>
Skill2 .....	<a href="#">256</a>
Skill3 .....	<a href="#">256</a>
skills .....	<a href="#">32, 243</a>
Smart Dial .....	<a href="#">234</a>
SMS .....	<a href="#">61</a>
start, configure, and monitor services .....	<a href="#">30</a>
Start/End .....	<a href="#">260</a>
start a service .....	<a href="#">30</a>
start control panel .....	<a href="#">31</a>
station .....	<a href="#">39</a>
StationDN .....	<a href="#">108, 125, 151, 202</a>
StationName .....	<a href="#">108, 125, 151, 202</a>
stations .....	<a href="#">32, 243</a>
Summary .....	<a href="#">233, 235</a>
support .....	<a href="#">20</a>
SuspendDuration .....	<a href="#">65</a>
SuspendReason .....	<a href="#">65</a>
SuspendWorkItem .....	<a href="#">65</a>
SwitchId .....	<a href="#">228</a>

### T

template .....	<a href="#">77</a>
The Multimedia Environment .....	<a href="#">71</a>
TIME .....	<a href="#">286</a>
Time Frames .....	<a href="#">260</a>
TN .....	<a href="#">256</a>
token .....	<a href="#">287</a>
Token value /e NEWTOKEN .....	<a href="#">280</a>
Topic .....	<a href="#">65–67</a>
training .....	<a href="#">19</a>
troubleshooting	
CM Admin .....	<a href="#">333</a>
ttrace logging .....	<a href="#">337</a>
turn off .....	<a href="#">28</a>

### U

UCID .....	<a href="#">64–67</a>
UniversalTime .....	<a href="#">108, 125, 151, 202</a>
user configuration .....	<a href="#">274, 276</a>
USERNAME .....	<a href="#">286</a>
Use time adjustment for time location .....	<a href="#">260</a>

**V**

ValidateContactForProgram .....	<a href="#">223</a>
Value .....	<a href="#">66</a>
VDN .....	<a href="#">39</a>
VDNs .....	<a href="#">32</a> , <a href="#">243</a>
Vector .....	<a href="#">256</a>
videos .....	<a href="#">19</a>
virtual agent .....	<a href="#">53</a> , <a href="#">59</a> , <a href="#">60</a> , <a href="#">62</a>
Virtual Agent .....	<a href="#">50</a> , <a href="#">52</a>
virtual agent workers .....	<a href="#">59</a>
voice media store .....	<a href="#">115</a>
Voice Media Store .....	<a href="#">85</a> , <a href="#">90</a>
voice portal .....	<a href="#">62</a>

**W**

Web Chat ASP .....	<a href="#">169</a>
Web Chat Gateway .....	<a href="#">70</a> , <a href="#">166</a>
WebLM .....	<a href="#">38</a>
WebLM mode .....	<a href="#">36</a>
web service .....	<a href="#">59</a> , <a href="#">60</a> , <a href="#">62</a>
web service method .....	<a href="#">64</a>
web service methods .....	<a href="#">64</a> – <a href="#">67</a>
TestConnectivity .....	<a href="#">67</a>
WINDIR .....	<a href="#">286</a>
WINSYSDIR .....	<a href="#">286</a>
WINTMPDIR .....	<a href="#">286</a>
work code .....	<a href="#">107</a> , <a href="#">124</a> , <a href="#">150</a> , <a href="#">201</a>
worker plug-in .....	<a href="#">62</a>
worker plug-ins .....	<a href="#">50</a> , <a href="#">52</a>
WorkItem .....	<a href="#">64</a>

**X**

XML Client .....	<a href="#">39</a>
XML protocol .....	<a href="#">39</a>
XML server .....	<a href="#">39</a> , <a href="#">41</a> , <a href="#">55</a> , <a href="#">102</a>
XML Server .....	<a href="#">50</a>
XML service .....	<a href="#">39</a>
XMPP Gateway .....	<a href="#">70</a>