



AVAYA IP Office DECT R4 Installation

Release 11.0
Issue 8c
September 2018

Contents

Chapter 1: DECT R4 Hardware	7
What's New.....	9
Base Stations.....	9
Base Station Types.....	9
IP Base Stations.....	11
Digital Base Stations.....	12
Base Station Details.....	13
Aerials.....	15
IP DECT Digital Gateway (IPBL).....	17
IP DECT Gateway Status Lamps.....	18
Phones.....	19
3720.....	20
3725.....	21
3730.....	22
3735.....	23
3740.....	24
3745.....	25
3749.....	26
Chargers.....	27
Avaya In-Building Wireless Server	28
AIWS1.....	28
AIWS2.....	30
Reset /Restart Switch.....	34
Chapter 2: Site Survey and Planning	35
Factors to Consider.....	37
Handover.....	38
Base Station Synchronization.....	39
Advanced Scenario: Separated Locations.....	39
Performing a Survey.....	40
Site Survey Mode.....	40
Chapter 3: Provisioned Installation	42
IP Office Installation Requirements.....	43
Information.....	43
Parts Required.....	43
Tools Required.....	43
IP Base Station Installation Requirements.....	43
Information.....	43
Parts Required.....	43
Phone Subscription Requirements.....	44

Information.....	44
Tools.....	45
Unpacking the DECT Software.....	45
Device Management.....	46
Configuring IP Office	47
Configuring Security Settings.....	47
Creating IP DECT Lines.....	50
Enabling Subscription.....	51
Adding Licenses.....	53
Configuring a Source Number.....	54
Master Base Station Setup.....	55
Defaulting the Base Station.....	55
Accessing the Base Station Configuration.....	56
Setting the Base Station IP Address.....	57
Configuring a Virtual Local Area Network (VLAN).....	58
Updating the Base Station Software.....	60
Selecting Administration Mode.....	62
Selecting Master Mode.....	63
Setting the DECT Password.....	64
Setting the Time Zone.....	65
Enabling Provisioning.....	65
Enabling HTTPS and Security Certificates in the Web Interface.....	66
Adding Radio Connections.....	68
Phonebook Integration.....	68
Performing an RFP Scan.....	69
Entering the PARI.....	70
Configuring Air Sync.....	70
IP Slave Base Station Setup.....	72
Defaulting the Base Station.....	72
Accessing the Base Station Configuration.....	73
Setting the Base Station IP Address.....	74
Updating the Base Station Software.....	75
Setting a Base Station to Slave Mode.....	77
Registering the Slave Base Station.....	79
Base Station Mounting.....	80
Mounting a Base Station using a Wallmount.....	80
Mounting a Base Station on a Column/Pillar.....	82
Subscribing Phones	82
Preconfigured Phone Subscription.....	83
Auto-Create Phone Subscription.....	83
Allowing Subscription.....	84
Manually Creating Extensions.....	85
Subscribing a Phone.....	87

Upgrading Phones.....	90
Displaying Subscribed Users.....	95
Unsubscribing Phones.....	96
Disabling Subscription.....	96
Chapter 4: DECT Resilience.....	98
Configuring Base Station Mirroring.....	98
Configuring the IP Office.....	99
Configuring the Mirrored Base Stations.....	99
Activating the Master Base Station.....	100
Configuring Switch Resilience.....	100
Provisioned Base Station Configuration.....	101
Non-Provisioned Base Station Configuration.....	102
IP Office Configuration for Switch Resilience.....	103
IP Office Line Configuration for DECT Resilience.....	103
Viewing and Controlling Resilience.....	104
Chapter 5: IP DECT Gateway Installation.....	105
IP DECT Gateway Installation Summary.....	105
Digital Base Station Power Consumption.....	106
Installing the Digital Base Stations.....	107
Mounting.....	107
Chapter 6: IP Office User Features.....	110
Idle Display.....	110
Status Indicators.....	111
Call Services.....	112
In Call Options.....	114
Call Waiting Options.....	116
Chapter 7: Device Management.....	117
Starting AIWS Device Manager.....	117
Loading Parameter Definition Files.....	118
Loading Phone Templates into Device Manager.....	120
Applying Templates to Phones.....	122
Editing Templates.....	123
Upgrading Phone Software.....	125
Installing Windows Device Manager to Upgrade Phones.....	125
Starting Windows Device Manager.....	128
Upgrading Phone Software.....	128
Chapter 8: AIWS Installation.....	131
Pre-Requisites.....	131
Parts Required.....	131
Information.....	131
Tools.....	132
Installing an AIWS1	132
Image Installation Mode.....	133

Removing the AIWS Cover.....	134
Connecting the RTC Battery.....	136
Connecting Cables to an AIWS.....	136
Accessing the AIWS Interface.....	137
Running the Setup Wizard.....	138
Enabling Base Station/AIWS Connection.....	144
Upgrading the AIWS Firmware.....	146
Switching Off the AIWS.....	152
Mounting the AIWS on a Wall.....	152
Replacing the AIWS Cover.....	153
Installing an AIWS2	154
Browsing to the AIWS2.....	154
Running the Setup Wizard.....	155
Enabling Base Station/AIWS Connection.....	161
Upgrading the AIWS Firmware.....	163
Chapter 9: Non-Provisioned Installation.....	165
IP Office Installation Requirements.....	165
Information.....	165
Parts Required.....	166
Tools Required.....	166
IP Base Station Installation Requirements.....	166
Information.....	166
Parts Required.....	166
Tools.....	167
Phone Subscription Requirements.....	167
Information.....	167
Tools.....	167
Unpacking the DECT Software.....	168
IP DECT Line Setup.....	169
Adding Licenses.....	170
Reserving Licenses.....	171
Configuring the Master Base Station.....	171
Pre-Requisites.....	172
Information.....	172
Parts Required.....	172
Tools.....	173
Defaulting the Base Station.....	173
Accessing the Base Station Configuration.....	174
Updating the Base Station Firmware.....	175
Setting the Base Station IP Address.....	177
Configuring a Virtual Local Area Network (VLAN).....	178
Setting the Time Source.....	180
QoS/ToS Settings.....	181

- Setting the Base Station as the Master..... 181
- Enabling Supplementary Services..... 183
- Setting the PBX Switch Mode..... 183
- Configuring IP Trunks 184
- Entering the Radio Settings..... 185
- Performing an RFP Scan..... 186
- Entering the PARI..... 186
- Entering the SARI/PARK..... 187
- Configuring Air Sync..... 187
- Integrating the IP Office Directory 189
- Resetting a Master Base Station..... 190
- Checking Master Base Station Radio..... 190
- Configuring IP Slave Base Stations 191
 - Pre-Requisites..... 192
 - Defaulting the Base Station..... 193
 - Accessing Base Station Configuration..... 194
 - Updating Base Station Firmware..... 195
 - Setting a Base Station IP Address..... 197
 - Setting a Base Station to Slave Mode..... 198
 - Resetting a Base Station..... 200
- Checking a Base Station Signaling Status..... 200
 - Master Base Station..... 200
 - Slave Base Station..... 201
- Mounting a Base Station 201
 - Mounting a Base Station using a Wallmount..... 201
 - Mounting a Base Station on a Column/Pillar..... 203
- Phone Subscription..... 203
 - Pre-Requisites..... 204
 - Allowing Subscription..... 204
 - Creating User Entries..... 206
 - Subscribing a Phone..... 208
 - Completing Anonymous Login..... 211
 - Disabling Subscription..... 211

Chapter 1: DECT R4 Hardware

Avaya DECT R4 is a Digital Enhanced Cordless Telecommunications system connecting multiple base stations using an IP LAN to provide an IP based cordless telephony and messaging system. This installation manual covers the installation of DECT R4 systems using the firmware supported by IP Office Release 110.0.

This document is a basic manual covering the most common install scenarios for DECT R4 with an IP Office system. For more advanced options and complex install scenarios refer to the full set of Avaya DECT R4 manual.

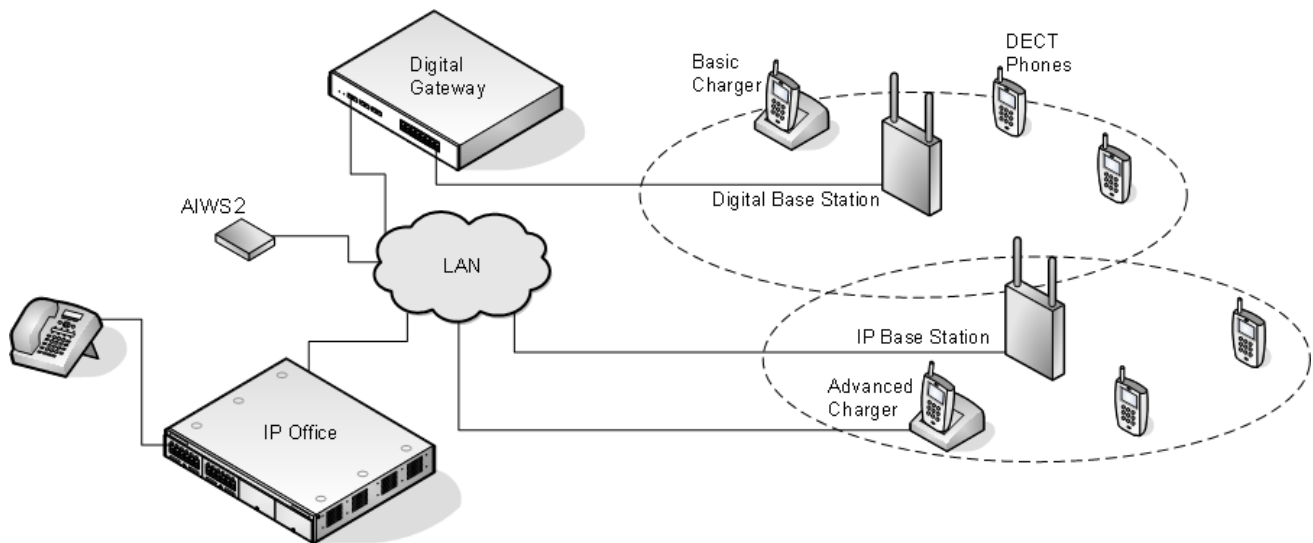

Hardware and Capacity:

- **IP Base Stations:** Up to 256 base stations (1 master + 255 slaves) are supported.

- **Standard [IP DECT Base Station \(IPBS\)](#)** on page 9

Standard stations have eight channels used for speech and messaging, and one channel which is reserved for broadcast messages. During installation one is configured as the master base station, to which the other base stations synchronize as slave base stations. Each base station can host up to 8 simultaneous phone conversations in its coverage area.

- **Compact Base Stations:**

Compact base stations are identical to standard base stations but only supports up to 4 simultaneous calls.

- **Digital Base Stations**

You can connect digital base stations to the DECT system using an IP DECT Gateway . These base stations are physically similar to the IPBS1 base stations, using the same casings and mounting brackets, but connect directly to an IP DECT Gateway using traditional 4-wire telephone cabling. Digital base stations are available in variants with internal and external aerials. There is no digital variant of the Compact Base Station base station.

- **Phones**

Up to 750 DECT phones are supported (384 on IP500 V2 systems). The Avaya 3700 Series phones supported are the **3720, 3725, 3730, 3735, 3740** and **3749**. See [Phones](#) on page 19. Other DECT phones, including the 3701 and 3711, are supported but only for basic telephony and only using the DECT GAP and DECT CAP standards.

- **Chargers**

A number of different types of charger exist for 3700 Series phones. See [Chargers](#) on page 27. Some of the chargers are advanced chargers which allow the phone docked with the charger to be accessed using the Device Manager application (browser access via the AIWS unit and charger LAN port or WinPDM application via the USB port).

- **IP Office**

DECT R4 is supported on IP Office systems running IP Office 5.0 and later software. This manual is for systems running IP Office Release 11.0 in any mode other than IP Office Basic Edition mode.

- **Licenses**

Each phone subscribed via the DECT R4 systems requires an **Avaya IP Endpoint** license in the IP Office configuration.

- **Configuration Tools**

- The tools and applications for DECT R4 are included as part of the IP Office Manager user and administration DVD. This includes the appropriate base station and phone firmware for their operation with the IP Office release.

- **Note:**

While the configuration tools are included in a .zip archive on the User and Administration DVD, the IP-DECT firmware needs to manually be installed. IP DECT firmware is also downloadable on the Avaya IP Office support site.

- **AIWS**

This unit allows SMS messaging between handsets. It also allows wireless software upgrades and configuration of the handsets (without an AIWS, handsets can only be upgraded and configured when in an advanced charger). For IP Office Release 5 this unit provides directory integration between the IP Office and the DECT R4 system. For IP Office Release 6 directory integration can be done by the master base station but without SMS support. If both SMS and directory integration are required then an AIWS unit must be used. See [Avaya In-Building Wireless Server \(AIWS\)](#) on page 28.

- **IP DECT Digital Gateway**

The IP DECT Gateway allows Digital base stations to be connected to the DECT system (see [Digital Base Stations](#) on page 12). An IPBL is intended to be used only if Digital base stations

will be deployed in an IP-DECT system. Up to 16 RFPs can be connected to the IPBL. The IPBL has eight channels for each RFP used for speech, message and alarm. The IPBL also has two channels which are reserved for messaging and alarm. Totally the IPBL has 40 speech channels. Up to 16 digital base stations can be connected to a gateway, using traditional 4-wire telephony cabling. The gateway itself connects to the IP Office and other IP based elements of the system via the IP LAN. See [IP DECT Digital Gateway \(IPBL\)](#) on page 17.

What's New

The following changes have been made for DECT R4 support in IP Office Release 11.0:

- **Maximum DECT Extension Capacity Increased on Linux-Based Systems:**

For DECT R4 systems linked to a Linux-based server, the maximum DECT R4 extension capacity has been increased from 384 to 750. The maximum limit on IP500 V2 systems (including Server Edition expansions) remains at 384.

- **Maximum Base Stations Capacity Increased:**

The maximum number of base stations supported in a DECT R4 system connected to IP Office has been increased from 128 to 256.

- **Compact Base Station Capacity Limitations Removed:**

The previous maximum limit of 5 for compact base stations has been removed. Any mix of compact and non-compact base stations is supported up to the overall base station limit above. Note however that base station mirroring between a compact and non-compact base stations is still not supported.

Base Stations

DECT R4 supports several base station variants. They differ in aerial connection, the number of simultaneous calls supported and how they connect to the DECT system. Normally, during installation, one of the base stations is configured as the master base station for the whole DECT R4 system. Remaining base stations are then configured as slave base stations.

The availability of particular base stations variants depends on the country of operation.

Base Station Types

The following types of base station are available for use in a DECT R4 system. They are available as IP and or digital versions. Each base station includes a detachable bracket for wall mounting or column mounting of the base station. The bracket allows the base station to be removed for

maintenance. The same brackets are used for all base station types , allowing for quick interchange of base stations.

- **Internal Aerial Base Stations**

These standard base stations have two internal aerials which cannot be adjusted. The aerials produce a directional pattern of radio coverage. The base station supports up to eight simultaneous calls. This type of base station is available in both IP (IPBS1 and IPBS2) base station and digital base station versions.

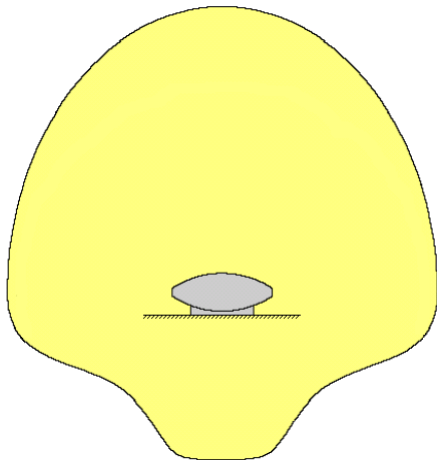

- **Compact Base Station**

This type of base station, available for IPBS1 and IPBS2, is physically similar to other base stations with internal aerials but only supports 4 simultaneous calls. Compact Base Stations are only supported if all other base stations are running firmware version 5.0.11 or later.

- **External Aerial Base Stations**

These base stations have two external aerials. These aerials produce an even pattern of radio coverage. The base station supports up to eight simultaneous calls. The aerials can be disconnected and replaced by a various other types of aerials if different radio coverage patterns and range is required. This type of base station is available in both IP (IPBS1 and

IPBS2) base station and digital base station versions. Note that the placement of the aerial connectors differs between IPBS1 and IPBS2.

This type of base station is not supported in North America.

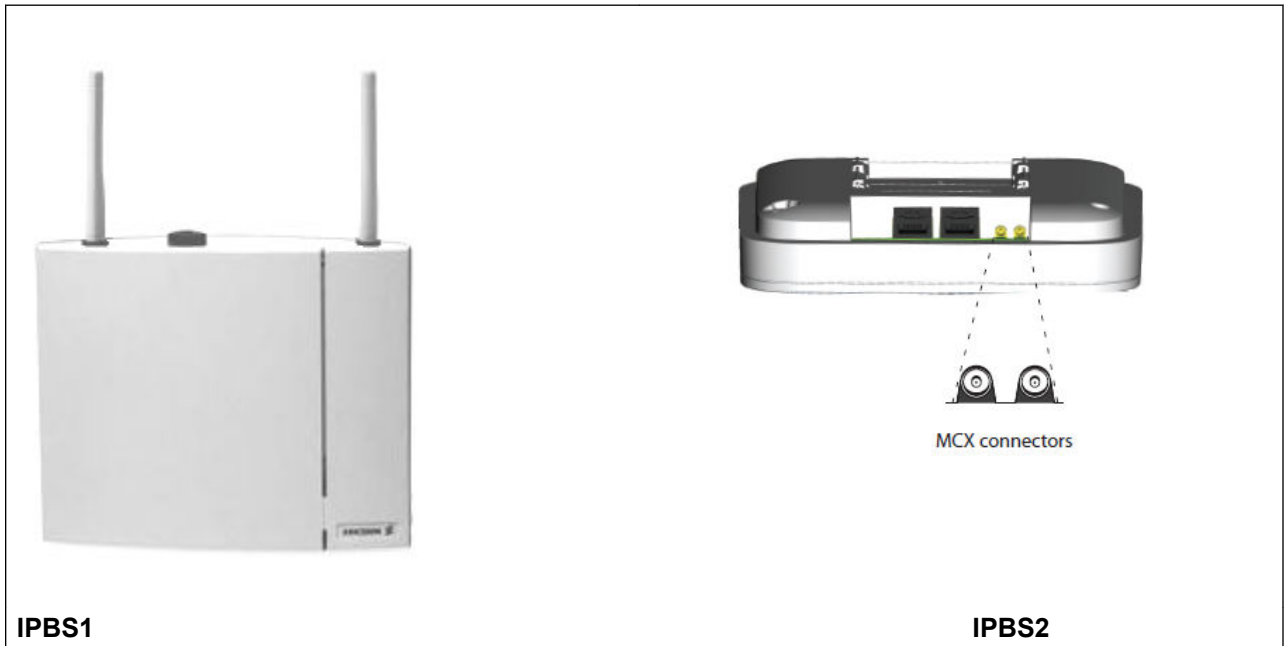

IPBS1

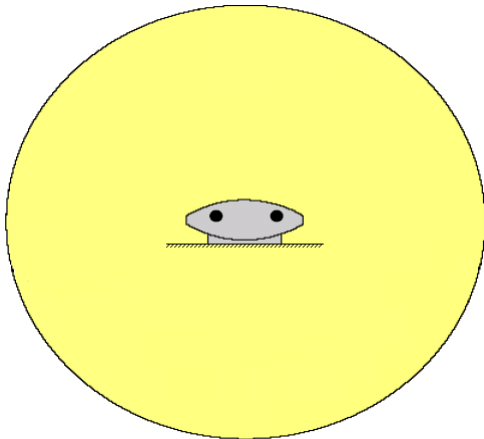

IP Base Stations

IP base stations are supplied with a mounting bracket and a 1.2 metre (4 foot) LAN cable. Power the base station using IEEE 802.3af Power over Ethernet (PoE). Alternatively, the base station might use an external power supply (Optional regional dependant part from Avaya) provided that an outlet socket exists within 8 metres (26 feet) cable distance.

The original IPBS1 versions of these base stations have been replaced by IPBS2 versions. The two types are functionally the same and can be mixed in the same installation. Avaya will continue to offer the same versions of the IPBS2 as were offered for the IPBS1

! Important:

For DECT firmware 10.0 and higher, supported with IP Office Release 10.0 and higher, IPBS1 base stations are only supported as slave radio base stations . IPBS1 base stations are no longer supported in other roles, for example as master base stations. For systems being upgraded, any existing IPBS1 base station being used such other roles must first be replaced in that role with an IPBS2 or IPBL1.

The IPBS2 products are fully interoperable with IPBS1 products and the IP DECT Gateway solution.

Digital Base Stations

You can connect digital base stations to the DECT system using an IP DECT Gateway . These base stations are physically similar to the IPBS1 base stations, using the same casings and mounting brackets, but connect directly to an IP DECT Gateway using traditional 4-wire telephone cabling.

Digital base stations are available in variants with internal and external aerials. There is no digital variant of the Compact Base Station base station.

- Digital Base Station with internal antennas for European Union, Switzerland, Iceland, Liechtenstein, Norway and Russia.
- Digital Base Station with external antennas for European Union, Switzerland, Iceland, Norway and Russia.
- Digital Base Station with internal antennas for US and Canada.

Digital base stations can be powered either direct from the IP DECT Gateway or using separate power adapters for each base station. The number of base stations that the IP DECT Gateway can power depends on the cable distance to each base station and the type of cable used. A table indicating the base station power consumption can be found under [Digital Base Station Power Consumption](#) on page 106. You can use the table to calculate whether the IP DECT Gateway can directly power the digital base stations. In cases where the IP DECT Gateway cannot directly power all the digital base stations, some of the base stations will need a separate power connection.

Base Station Details

Feature	Details	
DECT Frequencies	Brazil	1910-1920 MHz frequencies.
	Latin America	1910-1930 MHz frequencies.
	North America	1920-1930 MHz frequencies.
	Rest of World	1880-1900 MHz frequencies.
Physical	Dimensions (Height x Width x Depth)	165 x 200 x 56 mm (including mounting bracket). Add 95mm height for external aerials.
	Weight	450g
	Material	ABS moulded plastic
	Colour	Beige
	External connectors	2 x RJ45, 1 x RJ12
Power (IP Base Stations)	Input	Power over Ethernet IEEE 802.3af or local power supply
	Operating voltage	21 to 56 V dc.
	Power consumption	Typical 4W, maximum 5W.
	Power over Ethernet	PoE Class 2 (7W).
Network (IP Base Stations)	Ethernet:	10/100baseT
	Voice over IP	H.323 XMobile incl. QSig/DSS1.
	Voice Encoding	G.711 A-law / Mu-law (64kbps) G.723.1 (5.3 kbps) G.729A and AB (16 kbps) Note: Avaya recommends against using Audio codec G.723.1 for mixed installations containing both IPBS1 and IPBS2. 
Radio	RF output power EU	Between 23 dBm and 28 dBm (with internal antenna) Between 20 dBm and 25 dBm (with external antenna)
	RF output power US	Between 17 dBm and 21,6 dBm (with internal antenna)

Table continues...

Feature	Details	
Environmental	Operating temperature	-10°C to +55°C
	Storage temperature	-40°C to +70°C
	Relative operating humidity	15 to 90%, non condensing
	Relative storage humidity	5 to 95%, non condensing
	Immunity to electromagnetic fields	3V/m (EN61000-4-3)
	Immunity to ESD	4 kV contact discharge and 8 kV air discharge (EN61000-4-2)

Base Station Status Lamps

IPBS1 Base Stations

Each IPBS1 base station has two LED lamps.

LED	Color	Description
LED 2 - Activity	Off	Idle, no calls in progress.
	Green	Calls in progress.
	Green Flashing	Maximum calls in progress.
	Amber*	Air synchronization insufficient and calls in progress.
	Amber Flashing*	Air synchronization insufficient and no calls in progress.
	Amber Slow Flashing*	Air synchronization insufficient and maximum calls in progress.
	Red Flashing	No air synchronization. Searching for synchronization signal.
	Red Fast Flashing	Download of RFP software in progress.
LED 1 - Status This is the lower LED on the bottom edge of the base station.	Green	Operational
	Amber	TFTP Mode (<i>not used</i>).
	Amber Fast Flashing	Firmware download in progress.
	Alternating Red/Green	No Ethernet connection.
<p>Note:</p> <p> * All amber statuses are warnings that Air synchronization, although still adequate, is fading and might be lost. A flashing red indicates lost Air synchronization.</p>		

IPBS2 Base Stations

IPBS2 base stations have one LED to indicate status.

LED	Description
Blue On	Idle, no calls in progress.
Blue Fast Flash	Starting up or searching for air synchronization.
Blue On - Regular Blink	Calls in progress.
Blue On - Red Blink	Maximum calls in progress.
Blue Slow Flash	Firmware download in progress.
Yellow Fast Flash	IPBS2 is in mini firmware mode.
Yellow On	TFTP Mode (<i>not used</i>).
Red Fast Flash	No Ethernet connection.
Red On	Hardware error.
Blue On - Yellow Blink	The IPBS2 is in deployment mode and has air synchronization.
Red On - Yellow Blink	The IPBS2 is in deployment mode and has no air synchronization.
Blue Slow Flash/Yellow Flash	The IPBS2 is in deployment mode and does not have adequate air synchronization.
Green	Reset button depressed.

Digital Base Station

Digital base stations have two LED lamps.

LED	Color	Description
LED 2 - Activity	Off	Idle, no calls in progress.
	Green	Calls in progress.
	Green Flashing	Maximum calls in progress.
	Amber	Base station OK but not operational (self-test, no communication with IP DECT Gateway).
	Amber Flashing	Software download in progress.
LED 1 - Status This is the lower LED on the bottom edge of the base station.	Green	Operational
	—	—
	—	—

Aerials

The following aerials can be used to replace the supplied aerials on a base station with external aerials. These aerials have leads to allow for optimal positioning.

*** Note:**

These optional aerials are not supported in North America.

• **Omni-Directional Single Aerial**

A pair of these aerials can be used to approximately double the base station radio coverage, ie. up to 600 metres (2000 feet) omni-directional coverage.



• **Directional Dual Aerial**

This aerial gives directional coverage up to 750 metres (2500 feet). Only one aerial unit is required for connection to the base station.

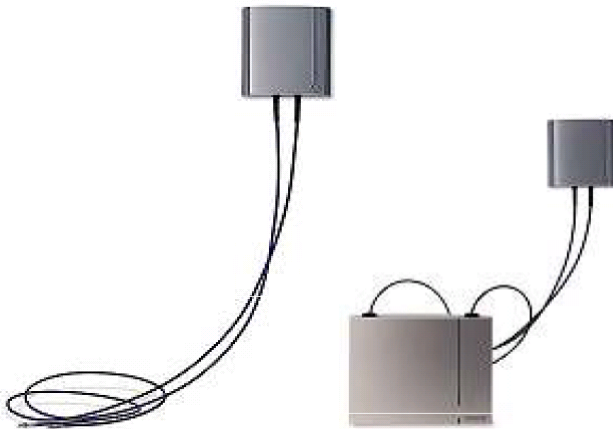

• **Directional Single Antenna**

A pair of these aerials can be used to give directional coverage up to 1000 metres (3300 feet). They must be mounted facing the same direction and approximately 1 metre (3 feet) apart. To achieve maximum coverage, the aerial should be mounted between 4 to 8 metres (13 to 26 feet) above area being covered.

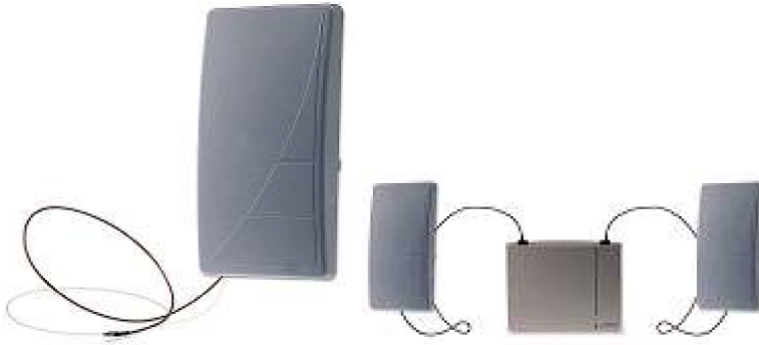

IP DECT Digital Gateway (IPBL)

The IP DECT Gateway allows digital base stations to be connected to the DECT system. Up to 16 digital base stations can be connected to a gateway, using traditional 4-wire telephony cabling. The gateway itself connects to the IP Office and other IP based elements of the system via the IP LAN.

Though the gateway does not support telephone calls without digital base stations connected, it can be configured to act as the master base station for the whole DECT system. It is possible for the gateway to act as a master even in a system that has a mix of IP and digital base stations.



The IP DECT GATEWAY provides the following features:

- Up to 16 digital base stations can be connected to an single IP DECT Gateway.
- Up to 8 IP DECT Gateway units are supported per IP Office.
- Synchronization of attached digital base stations via UPN cables (including automatic cable delay measurement).
- Over-the air synchronization master for IP base stations. Master sync or backup sync functionality can reside in the gateway appliance. It cannot be slave sync.
- Seamless roaming and handover, also with IP base station on same site.
- The IP DECT Gateway can act as the master base station for the DECT system. This does not affect the count of actual base stations (IP and or digital) allowed.
- Remote configuration and software upgrade of IP DECT Gateway appliance (web-based).
- Remote automatic update of digital base stations connected to the IP DECT Gateway.

- Configuration option for reuse of Avaya UPN repeaters. This means a configuration option for each base station port to disable the automatic cable delay measurement and allow to manually set a cable delay value for that specific port.
- Remote power feeding of digital base stations via UPN ports. The maximum cable length between the IP DECT Gateway and each digital base station should not exceed 1500 meters. The length and type of cable used affects the power consumption of the base station. If the total power capacity of the IP DECT Gateway is exceeded, additional digital base stations will require their own power support connection.

Note: The IP DECT Gateway does not support call handover when the digital base station used for that call is reset or unplugged. This means that calls lost on one digital base station will not transfer to another digital base station.

IP DECT Gateway Status Lamps

IP DECT Gateway Status Lamp

This LED is located at the left-hand end of the front panel of the IP DECT Gateway.

LED	Description
Off	No power.
Green slow flash	Reset switch pressed.
Green fast flash	Firmware update in progress or config cleared after reset.
Green on	OK.
Red on	Error.
Amber on	TFTP mode.

Base Station Port Lamps

Each base station port has a left-hand and right-hand LED. These are used as follows:

Left-hand LED		Right-hand LED	
LED	Description	LED	Description
Off	No link to base station.	Off	No calls in progress.
On	Linked and base station operational.	On	Calls in progress.
Flashing	Linked but base station not operational.	Flashing	Maximum calls in progress.

LAN Port Lamps

Each LAN port has a left-hand and right-hand LED. These are used as follows:

Left-hand LED		Right-hand LED	
LED	Description	LED	Description
Off	No link or Ethernet connection.	Off	No connection or 10Mbps connection.
On	No network activity.	On	100Mbps connection
Flashing	Network activity.	—	—

Phones

The following Avaya 3700 Series phones are supported by DECT R4:

- [3720](#) on page 20
- [3725](#) on page 21
- [3730](#) on page 22
- [3735](#) on page 23
- [3740](#) on page 24
- [3745](#) on page 25
- [3749](#) on page 26

3720

Avaya 3720	Features		
	<ul style="list-style-type: none"> • High quality voice DECT phone, GAP/CAP compliant. • Easy access to PBX services. • Voicemail including message icon. • Manual and automatic keypad lock. • Local directory: 250 entries. • Central directory from the IP Office. 		
	Dimensions	133 x 53 x 24mm	
	Weight	115g	
	Battery Type	600 mAh, Lithium 3.7V. Charge time 4 hours.	
	Speech Time	> 16 hours.	
	Standby Time	> 160 hours.	

- For systems installed using IP Office provisioning, the language used is set by the IP Office system or user language setting.
- An additional language file can be uploaded to a phone.

3725

Avaya 3725	Features	
	<ul style="list-style-type: none"> • As per 3720 plus: • Site Survey tool. • Cleanable, IP 44. • Option: Bluetooth. • 19 Languages Czech, Danish, Dutch, English, Finnish, French, German, Greek, Hungarian, Italian, Norwegian, Polish, Portuguese (Brazilian), Portuguese, Russian, Slovakian, Spanish, Swedish and Turkish. • SMS Message length up to 160 characters. 30 received/sent messages. Requires AIWS. 	
	Dimensions	134 x 53 x 26mm
	Weight	130g
	BatteryType	930 mAh, Li-Pol 3.7V. Charge time 4 hours.
	Speech Time	> 20 hours (13h with Bluetooth option)
	Standby Time	> 120 hours.

- For systems installed using IP Office provisioning, the language used is set by the IP Office system or user language setting.
- An additional language file can be uploaded to a phone.

3730

Avaya 3730	Features	
	<ul style="list-style-type: none"> • High quality voice DECT phone, GAP/CAP compliant • Easy access to PBX services • Voicemail including message icon. • Manual and automatic keypad lock • Local directory: 250 entries. • Central directory from the IP Office. • Call list with the 25 last calls • Vibrator • Loudspeaker/hands free • Central Management and software download • Headset socket (3.5mm). • 19 Languages Czech, Danish, Dutch, English, Finnish, French, German, Greek, Hungarian, Italian, Norwegian, Polish, Portuguese (Brazilian), Portuguese, Russian, Slovakian, Spanish, Swedish and Turkish. • Color display (1.8", 128 x 160 pixels). 	
	Dimensions	136 x 53 x 21mm
	Weight	115g
	Battery Type	600 mAh, Lithium 3.7V. Charge time 4 hours.
	Speech Time	> 16 hours.
	Standby Time	> 160 hours.

- For systems installed using IP Office provisioning, the language used is set by the IP Office system or user language setting.
- An additional language file can be uploaded to a phone.

3735

The 3735 is available in two versions, one with support for integrated alarm button functions and one without alarm button support.

Avaya 3735	Features		
 <p>The image shows a black Avaya 3735 mobile phone. The screen displays the time 07:30 and the word 'Messaging'. Below the screen is a navigation pad with a central circular button and four surrounding buttons. At the bottom is a standard 12-key numeric keypad.</p>	<p>As per the 3730 plus:</p> <ul style="list-style-type: none"> • Alarm button • Cleanable, IP44 • Option: Bluetooth for headset • Color display (2", 240 x 320 pixels). • SMS <p>Message length up to 160 characters. 30 received/sent messages. Requires AIWS.</p>		
	Dimensions	136 x 53 x 21mm	
	Weight	130g	
	Battery Type	920 mAh, Li-Pol 3.7V. Charge time 4 hours.	
	Speech Time	> 20 hours (13 hours with Bluetooth option).	
	Standby Time	> 120 hours.	

- For systems installed using IP Office provisioning, the language used is set by the IP Office system or user language setting.
- An additional language file can be uploaded to a phone.

3740

Avaya 3740	Features		
	<ul style="list-style-type: none"> • High quality voice DECT phone, GAP/CAP compliant • Easy access to PBX services • Voicemail including message icon. • Manual and automatic keypad lock • Local directory: 250 entries. • Central directory from the IP Office. • Call list with the 25 last calls • Vibrator • Loudspeaker/hands free (full-duplex) • Central Management and software download • Headset socket (IP65 plug). • 19 Languages Czech, Danish, Dutch, English, Finnish, French, German, Greek, Hungarian, Italian, Norwegian, Polish, Portuguese (Brazilian), Portuguese, Russian, Slovakian, Spanish, Swedish and Turkish. • Ruggedized. • IP65 Classified. • Wide temperature range: -10C to 55C. • Monochrome display (128 x 160 pixels). • SMS Message length up to 160 characters. 30 received/sent messages. Requires AIWS. • GAP compatible. 		
	<table border="1"> <tr> <td data-bbox="657 1438 893 1480">Dimensions</td> <td data-bbox="893 1438 1481 1480">143 x 59 x 29mm</td> </tr> </table>	Dimensions	143 x 59 x 29mm
	Dimensions	143 x 59 x 29mm	
	<table border="1"> <tr> <td data-bbox="657 1480 893 1522">Weight</td> <td data-bbox="893 1480 1481 1522">180g</td> </tr> </table>	Weight	180g
	Weight	180g	
	<table border="1"> <tr> <td data-bbox="657 1522 893 1564">Battery Type</td> <td data-bbox="893 1522 1481 1564">920 mAh, Li-Ion 3.7V. Charge time 4 hours.</td> </tr> </table>	Battery Type	920 mAh, Li-Ion 3.7V. Charge time 4 hours.
Battery Type	920 mAh, Li-Ion 3.7V. Charge time 4 hours.		
<table border="1"> <tr> <td data-bbox="657 1564 893 1606">Speech Time</td> <td data-bbox="893 1564 1481 1606">> 18 hours.</td> </tr> </table>	Speech Time	> 18 hours.	
Speech Time	> 18 hours.		
<table border="1"> <tr> <td data-bbox="657 1606 893 1652">Standby Time</td> <td data-bbox="893 1606 1481 1652">> 150 hours.</td> </tr> </table>	Standby Time	> 150 hours.	
Standby Time	> 150 hours.		

- For systems installed using IP Office provisioning, the language used is set by the IP Office system or user language setting.
- An additional language file can be uploaded to a phone.

3745

Avaya 3740	Features		
	<ul style="list-style-type: none"> • High quality voice DECT phone, GAP/CAP compliant • Easy access to PBX services • Voicemail including message icon. • Manual and automatic keypad lock • Local directory: 250 entries. • Central directory from the IP Office. • Call list with the 25 last calls • Vibrator • Loudspeaker/hands free (full-duplex) • Central Management and software download • Headset socket (IP65 plug). • 19 Languages Czech, Danish, Dutch, English, Finnish, French, German, Greek, Hungarian, Italian, Norwegian, Polish, Portuguese (Brazilian), Portuguese, Russian, Slovakian, Spanish, Swedish and Turkish. • Ruggedized. • IP65 Classified. • Wide temperature range: -10C to +55C. • Colour display (128 x 160 pixels). • SMS Message length up to 160 characters. 30 received/sent messages. Requires AIWS. • GAP compatible. 		
	<table border="1"> <tr> <td data-bbox="657 1438 893 1480">Dimensions</td> <td data-bbox="893 1438 1474 1480">143 x 59 x 29mm</td> </tr> </table>	Dimensions	143 x 59 x 29mm
	Dimensions	143 x 59 x 29mm	
	<table border="1"> <tr> <td data-bbox="657 1480 893 1522">Weight</td> <td data-bbox="893 1480 1474 1522">180g</td> </tr> </table>	Weight	180g
	Weight	180g	
	<table border="1"> <tr> <td data-bbox="657 1522 893 1564">Battery Type</td> <td data-bbox="893 1522 1474 1564">920 mAh, Li-Ion 3.7V. Charge time 4 hours.</td> </tr> </table>	Battery Type	920 mAh, Li-Ion 3.7V. Charge time 4 hours.
Battery Type	920 mAh, Li-Ion 3.7V. Charge time 4 hours.		
<table border="1"> <tr> <td data-bbox="657 1564 893 1606">Speech Time</td> <td data-bbox="893 1564 1474 1606">> 12 hours with Bluetooth, 10 hours without..</td> </tr> </table>	Speech Time	> 12 hours with Bluetooth, 10 hours without..	
Speech Time	> 12 hours with Bluetooth, 10 hours without..		
<table border="1"> <tr> <td data-bbox="657 1606 893 1650">Standby Time</td> <td data-bbox="893 1606 1474 1650">> 90 hours.</td> </tr> </table>	Standby Time	> 90 hours.	
Standby Time	> 90 hours.		

- For systems installed using IP Office provisioning, the language used is set by the IP Office system or user language setting.
- An additional language file can be uploaded to a phone.

3749

Avaya 3749	Features			
	<ul style="list-style-type: none"> • High quality voice DECT phone, GAP/CAP compliant • Easy access to PBX services • Voicemail including message icon. • Manual and automatic keypad lock • Local directory: 250 entries. • Central directory from the IP Office. • Call list with the 25 last calls • Vibrator • Option: Bluetooth. • Loudspeaker/hands free (half-duplex) • Central Management and software download • Headset socket (IP65 plug). • 19 Languages Czech, Danish, Dutch, English, Finnish, French, German, Greek, Hungarian, Italian, Norwegian, Polish, Portuguese (Brazilian), Portuguese, Russian, Slovakian, Spanish, Swedish and Turkish. • Ruggedized. • IP65 Classified. • Intrinsically Safe. Conforms to ATEX/IECEX • Wide temperature range: -10C to +40C. • Colour display (128 x 160 pixels). • SMS Message length up to 160 characters. 30 received/sent messages. Requires AIWS. • GAP compatible. 			
	<table border="1"> <tr> <td>Dimensions</td> <td>143 x 59 x 29mm</td> </tr> </table>	Dimensions	143 x 59 x 29mm	
	Dimensions	143 x 59 x 29mm		
	<table border="1"> <tr> <td>Weight</td> <td>180g</td> </tr> </table>	Weight	180g	
	Weight	180g		
<table border="1"> <tr> <td>Battery Type</td> <td>920 mAh, Li-Ion 3.7V. Charge time 4 hours.</td> </tr> </table>	Battery Type	920 mAh, Li-Ion 3.7V. Charge time 4 hours.		
Battery Type	920 mAh, Li-Ion 3.7V. Charge time 4 hours.			
<table border="1"> <tr> <td>Speech Time</td> <td>> 12 hours with Bluetooth, 10 hours without..</td> </tr> </table>	Speech Time	> 12 hours with Bluetooth, 10 hours without..		
Speech Time	> 12 hours with Bluetooth, 10 hours without..			
<table border="1"> <tr> <td>Standby Time</td> <td>> 90 hours.</td> </tr> </table>	Standby Time	> 90 hours.		
Standby Time	> 90 hours.			

- Due to the power restrictions for intrinsically safe handset operation, the display brightness is lower, the loudspeaker and ringer volumes are lower and the audible ringer and vibrating

alert cannot be activated simultaneously. An additional language file can be uploaded to a phone.

- For systems installed using IP Office provisioning, the language used is set by the IP Office system or user language setting.
- An additional language file can be uploaded to a phone.

Chargers

A number of different types of charger exist for 3700 Series phones. Note that chargers are not necessarily interchangeable between different phone models.

- **Basic Chargers**

These are simple single-phone charger for charging only.



- **Advanced Chargers**

These are single-phone chargers with USB and LAN sockets. These allow the phone docked with the charger to be accessed using the Device Manager application (browser access via the AIWS unit and charger LAN port or WinPDM PC application access via the USB port).



- **Rack Chargers**

These are 6 phone advanced chargers.



- **Battery Chargers**

These chargers allows the charging of up to 6 batteries separate from the phones.



Avaya In-Building Wireless Server

The AIWS (*Avaya In-Building Wireless Server*) unit allows SMS messaging between handsets. It also allows wireless software upgrades and configuration of the handsets. Without an AIWS, handsets can only be upgraded and configured when in an advanced charger or a rack charger.

For IP Office Release 5 this unit also provides directory integration between the IP Office and the DECT R4 system.

For IP Office Release 6 and later, directory integration is done by the master base station when the AIWS is not present. However, an AIWS is still required for both functions if SMS is needed.

The unit is managed by means of a web browser and requires a fixed IP address.

For IP Office 8.0, the AIWS2 is supported. The AIWS2 is the application server for the DECT R4 system that has replaced the AIWS1 design.

AIWS1

In this release of IP Office, this design of AIWS has now been replaced by the AIWS2.

Table 1: AIWS1



Several variants of the server are available. There is no upgrade available between variants.

Feature\AIWS2 Variant	Basic	Standard	Enterprise	OAP
Feature\AIWS2 Variant	Basic	Standard	Enterprise	OAP
Central Phonebook	Yes	—	Yes	Yes
Corporate Directory Access	Yes (TFTP only)	Yes (TFTP and LDAP)	—	—
SMS Support	Yes	Yes	Yes	Yes
Basic Web Messaging	Yes	Yes	Yes	Yes
Netpage Web Messaging	—	Yes	—	—
Over-the-Air Handset Software Upload	—	Yes	Yes	—
Over-the-Air Handset Configuration Upload	Yes	Yes	Yes	—
Handset Software Upload via Advanced/Rack Charger	—	Yes	Yes	—

Table continues...

Feature\AIWS2 Variant	Basic	Standard	Enterprise	OAP
handset Configuration Upload via Advanced/Rack Charger	—	Yes	Yes	—
Virtual SIM Card	—	Yes	Yes	—
AIWS as Protocol Converter	—	—	—	Yes

AIWS1 Status Lamp

Colour	State	Description
Green	On	Running
	On	Failsafe or Network setup mode
Orange	Flashing (1 second on/off)	Image installation mode
	Fast flash (100ms on/off)	Starting
	Intermittent flash (100ms on/1 second off)	Restart
	Slow flash (2 seconds on/3 seconds off)	Halted (auto restart after 10 minutes)
	Wink (5 seconds on/100ms off)	Unlicensed
	Wink (5 seconds on/100ms off)	Unlicensed
Red	On	Low voltage
	Intermittent flash (100ms on/1 second off)	License error
	Flashing (1 second on/off)	Watch dog reset
	Slow flash (2 seconds on/3 seconds off)	Shutdown
	Very slow flash (3 seconds on/3 seconds off)	Memory error
	Wink (5 seconds on/100ms off)	Network error/Module key error

AIWS2

IP Office 8.0, supports the AIWS2. The AIWS2 is an application server for the system. It can run applications such as SMS messaging, centralized phonebook, and corporate directory access. The AIWS2 supports centralized device management, including firmware and configuration upgrades over the air.

The AIWS2 has replaced the AIWS1



- Wall mounting brackets are included with the unit. Various other mounting kits are available.
- Built-in power supply: The AIWS is supplied with a number of power leads suitable for most locales.
- For installation and maintenance, this server is managed by a PC using Windows Internet Explorer (7.0 or above) and Sun's Java Runtime Environment.

Several variants of the server are available. There is no upgrade available between variants.

Feature\AIWS2 Variant	Basic	Basic+	Standard	OAP
NTP Server	Yes	Yes	Yes	Yes
Central Phonebook	Yes	Yes	Yes	Yes
Corporate Directory Access (TFTP from IP Office)	Yes	Yes	Yes	—
SMS Support	Yes	Yes	Yes	Yes
Basic Web Messaging	Yes	Yes	Yes	Yes
Netpage Web Messaging	—	Yes[1]	Yes	—
Over-the-Air Handset Software Upload	—	Yes[1]	Yes[2]	—

Table continues...

Feature\AIWS2 Variant	Basic	Basic+	Standard	OAP
Over-the-Air Handset Configuration Upload	—	Yes[1]	Yes[2]	—
Handset Software Upload via Advanced/Rack Charger	—	Yes[1]	Yes[2]	—
Handset Configuration Upload via Advanced/Rack Charger	—	Yes[1]	Yes[2]	—
Virtual SIM Card	—	Yes[1]	Yes[2]	—
AIWS as Protocol Converter	—	—	—	Yes

1. Up to 32 handsets.
2. Up to 120 handsets.

AIWS2 Hardware

Front Panel



1. Power LED

Indicates the status of the power supply to the unit. See [AIWS2 Status Lamps](#) on page 33.

2. Status LED

Indicates the status of the unit.

3. Mode Switch and LED

Pressing this switch twice will put the unit into mass storage mode. The unit will automatically return to normal operation after 10 minutes. While in mass storage mode, the LED in the switch flashes. Mass storage mode is used to allow a Windows PC to download the suitable drivers for USB cable connection to the Management port.

4. Restart Switch**5. SD Card Slot**

Not used for IP Office operation.

6. USB Ports

Not used for IP Office operation.

7. Management Port

This port can be used for a USB connection to a PC in order to do unit configuration. Installation of the drivers for this requires the unit to be put into mass storage mode using the Mode Switch (see above). The address used for this port is 192.5.36.229.

Rear Panel**1. LAN 1**

This is the LAN port which should be used for connection to the same LAN as the DECT system and IP Office.

2. LAN 2

Not used.

3. Power Connectors

The unit supports a number of different methods for power connection. If using the C10 port, a number of power cables are supplied with the unit.

AIWS2 Status Lamps**Status LED**

Colour	State	Description
Blue	On	OK. AIWS operational.
	Fast Flash	Starting up or shutting down.
Red	Fast flash	Error or fault.
	Slow flash	Warning
Yellow	Double blink	Waiting for automatic startup.

Power LED

Colour	State	Description
Blue	On	Power OK.
Red	Fast flash	Shutting down due to low voltage.
	Slow flash	Low voltage.

Mode LED

This LED is incorporated into the Mode button on the front of the unit.

Colour	State	Description
Blue	Slow flash	Mass storage mode.

Reset /Restart Switch

The base stations (all types), IP DECT Gateway and AIWS2 all include a reset switch. To press it requires a fine point. How long the switch is depressed affects the type of reset.

Action	Duration	Effect
Short press	Less than 1 second	Restart
Medium press	Approximately 3 seconds	Restart in TFTP mode. This mode is intended for development only.
Long press	Approximately 10 seconds	Factory reset. All configuration parameters will be set to default values.

Chapter 2: Site Survey and Planning

Avaya cannot give precise recommendations for a site survey as every site will vary. However, a site survey is a prerequisite to installation in all cases. The correct and effective placement of base stations will prevent problems and maximize coverage. Most issues with any DECT system will arise from the number and positioning of the base stations.

The basic aim is to ensure:

- Base station coverage in all areas of expected DECT phone usage.
- Sufficient number of base stations covering each area for the number of expected simultaneous users (up to 8 per base station) in that area.
- Sufficient overlap between areas of base station coverage to allow for call handover when DECT phone users are moving.
- Where possible, synchronization of each base station with more than one other base station.

The diagram below indicates the basic measures for coverage between a base station and a DECT phone.

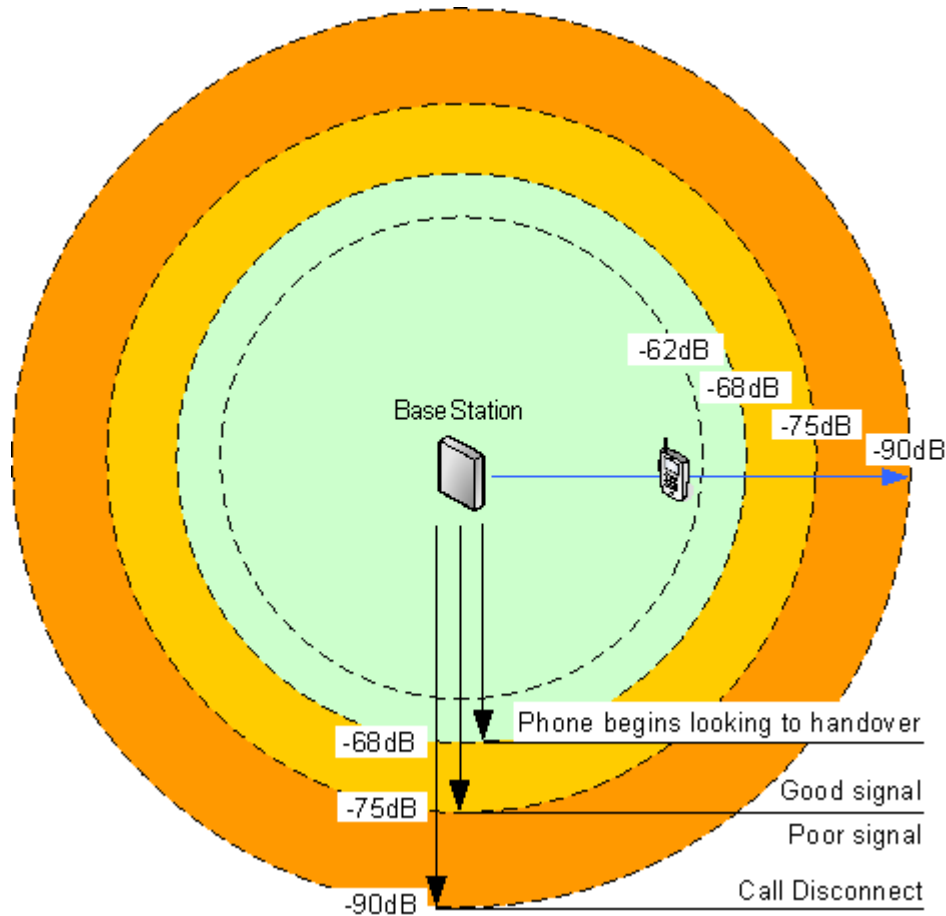

Signal	Description
-40dB	Strong signal typically seen when a phone is close to the base station.
-62dB	Minimum signal strength at which a base station will accept a phone wanting to handover from another base station.
-68dB	Signal strength below which the phone will begin looking for a base station to which it can handover.
-75dB	At this signal strength, the increased error rate will become apparent in the speech.
-90dB	At this signal strength calls are likely to disconnect. This is also the limit for one base station to synchronize with another.

Though this section focuses mainly on the measure of signal strength, the DECT signalling employs a number of methods to overcome a poor signal. The other key factor that affects signalling is the error rate. While decreasing signal strength and increasing error rate are usually related, there may be some scenarios where a higher than expected error rate occurs.

Factors to Consider

In ideal open field conditions, the range between a phone and a standard base station can be up to 600 metres (2000 feet). However, in real conditions with obstacles absorbing signal strength and reflected signals giving increased error rates, the range is more realistically between 30 metres (100 feet) indoors and 300 metres (1000 feet) outdoors.

In practice, no rules or guarantees can be specified for base station coverage. Coverage is affected by too many factors that are unique to each site. The following is a guide to those factors that can affect coverage which you should consider and look for during any site survey.

- **Obvious causes of signal problems**

- Metal surfaces.
- Concrete thickness greater than 1 metre (3 feet).

- **Beware of**

- **Windows with Reflective Film or Specialized Glass.**

These produce increased signal reflection and reduced signal pass-through.

- **Wire Meshes and Grills with Apertures of Less than 4cm (1.5 inches).**

These block signals as effectively as continuous metal sheet.

- **Fire Doors**

These block the signals. In multi-occupancy building such as hotels, the high number of fire-doors may be a problem.

- **Stair Wells**

In modern office buildings, stair wells frequently combine concrete building supports, fire doors and the intervening floor material, making them a special problem.

- **Screened Rooms**

Typically found in offices involved with TV, video and radio production, but also possible in computer centers.

- **Empty Sites**

Do not perform a survey on a site that is not yet occupied. The survey results will differ from those of the same site once occupied by the customer business. Similarly the survey should be performed during normal business hours in order to assess the areas of usage and the effect of equipment being operated and moved.

- **Be aware of**

- **Signal Direction**

The signal from a base station does not propagate evenly in all directions. The signal typically propagates strongest in the horizontal plane. However the ability for a base station to serve callers located on floors above or below it should not be ignored. This may allow coverage to be extended to areas not frequently used and so not meriting a dedicated local base station.

- Other Radio Signals

The ability to receive normal broadcast radio signals in an area is not an indication that DECT signaling will be received and vice versa.

- Rack Chargers

A rack charger (6 phones) immediately creates an area where a single base station (8 calls) would be near maximum capacity. Look to provide overlapping base station support to areas where rack chargers will be located.

Handover

Once a phone is connected on a call through a particular base station, it will normally maintain connection with that base station even if the phone moves into an area with a stronger signal from another base station. However, when the signal to the phone drops below -68dB, the phone will begin looking for another base station with a better signal to which it can handover (this is often referred to as "roaming"). If the other base station signal is -62dB or higher, the phone will handover to that base station if it has free capacity.

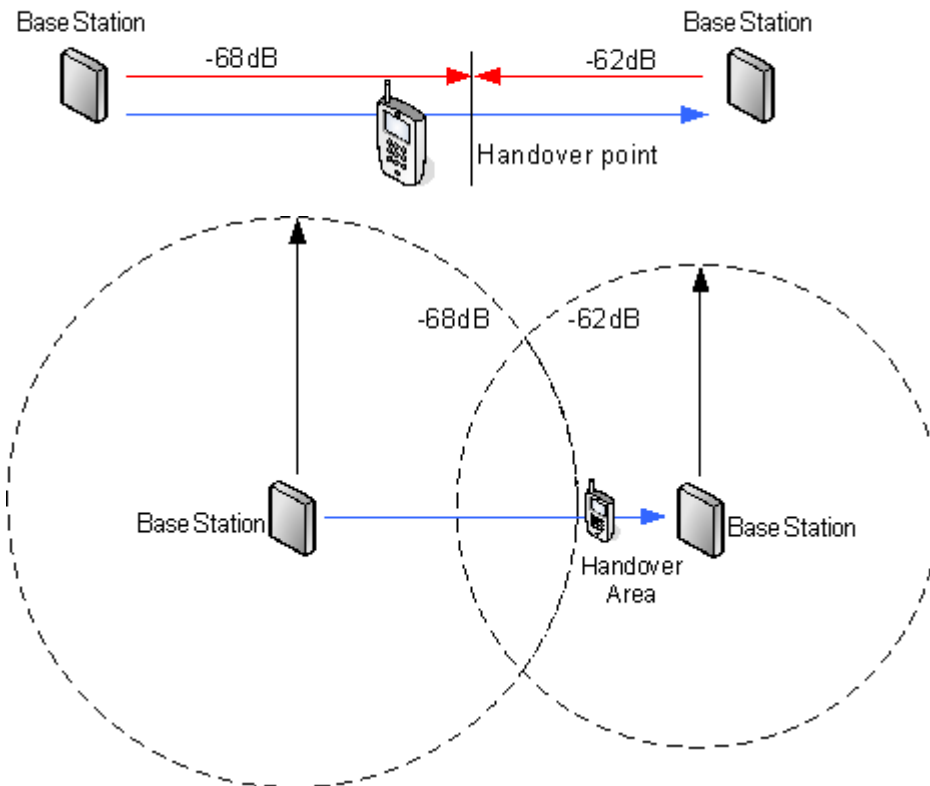

Base Station Synchronization

Base stations in the DECT R4 system need to be synchronized with each other. This can be done with a signal as low as -90dB between base stations.

One base station is assigned as the 'air sync master', typically the master base station. Each other base station can sync directly with it or indirectly via a synchronization chain. However, it is preferable that the number of synchronization 'hops' between any particular base station and its air sync master base station is kept as low as possible. To help achieve this it is recommended that the air sync master is placed centrally within the set of base stations.

Where possible, each base station should be placed within synchronization range of more than one base station, which allows the base stations to maintain synchronization should one base station fail or be switched off for maintenance. The process of synchronizing by the shortest route to the air sync master when in synchronization range of multiple base stations is automatic.

For more information, see [Configuring Air Sync](#) on page 70.

Advanced Scenario: Separated Locations

In most scenarios, the master base station (Standard or Compact) is also used as the air sync master for all the other slave base stations and that is the scenario documented in this manual. However, in scenarios where you have base stations in separate locations that are not within synchronization range of each other, it is permissible to assign separate air sync masters in each location. However, there must be absolutely no overlap (<-90dB) between the separate groups of base stations. Any overlap will cause frequent loss of synchronization.

Having separate locations, each with its own synchronization, is done through the settings on the **DECT | Air Sync** tab of each base station. For each location, set the same **Sync Region** number for all the base stations at that location, using a different number for each location. In addition, use the **Sync Mode** drop-down menu to configure one of the base stations in each location as the **Master** base station.

 **Note:**

In deployments in mixed systems with IP Base Stations and IP-DECT Gateways, the IP-DECT Gateways need to be physically interconnected for the purpose of radio synchronization. When configuring an IP-DECT Gateway as an air sync master, use sync region 0. All other base stations should be configured as sync slaves. Systems with IPBS in sync regions that have only IPBS should use non-zero sync region number(s) and be configured with at least one sync master with the remaining IPBSs configured as sync slaves.

Performing a Survey

- While performing a survey you will require the following information:

- **Building Layout**

Accurate building plans are an essential aid to both the site survey and also for later fault analysis. Ensure that you have an accurate plan of the customer premises, including the locations of mains power outlets and network connection points.

- **The area of coverage required**

Which areas within the plans the customer expects to be covered. Do they expect coverage outside the building and or in buildings separate from the main building.

- **The number of simultaneous users within different areas**

Each base station can support up to 8 simultaneous calls (4 for a Compact Base Station).

- Perform the survey during normal business hours. The movement of large items of machinery, such as lifts and shutter doors, will then be observable during the survey.
- Ensure that you have read this documentation and understand the requirements of both phone handover and base station synchronization.
- As the survey occurs, note whether additional network connection points are required and check for main power outlets. Consider the use of Power over Ethernet, if possible, in order to simplify base station installation.

Site Survey Mode

About this task

The following method is used to put a subscribed phone into site survey mode.

Procedure

1. Go to the **Call Time** menu (**Menu | Calls | Call Time**).
2. Activate the **Admin** menu by pressing ► * ◀ ◀ * ◀.
3. In **Admin** menu, select **DECT Info**.
4. Select **Link**. The phone will display information about the base station.



- **C7 S10**

This is the DECT signal carrier and slot.

- **ss**

This is the signal strength. This is the main value that should be recorded and accessed as you perform the survey.

Signal	Description
-40dB	Strong signal typically seen when a phone is close to the base station.
-62dB	Minimum signal strength at which a base station will accept a phone wanting to handover from another base station.
-68dB	Signal strength below which the phone will begin looking for a base station to which it can handover.
-75dB	At this signal strength, the increased error rate will become apparent in the speech.
-90dB	At this signal strength calls are likely to disconnect. This is also the limit for one base station to synchronize with another.

- **Error rate / Q2 Error rate**

These are the error (corrupted) frames per second on the signals from and to the base station.

- **PARI**

The PARI of the DECT system.

- **Bear:**

The current power output of the phone.

- **Pwr** = on hook
- **LU** = off hook, Low power
- **US** = off hook, Normal power
- **EU** = off hook, High power

Chapter 3: Provisioned Installation

A provisioned installation is the recommended method for both installation simplicity and handset feature support. Use Provisioned Installation for all deployments of systems comprised of only Avaya 3700 Series phones.

- **When to Use IP Office Provisioning**

IP Office provisioning simplifies installation and maintenance and provides 3700 Series phones with additional IP Office specific features (see [IP Office User Features](#) on page 110). Avaya recommends this installation method for new installations whenever possible.

- Provisioned installation in pre-configured or auto-create modes should be used for all installations with just 3700 Series phones.
- Provisioned installation in pre-configured mode should be used for all installations with a mix of 3700 Series phones and other DECT phones.
- Provisioned installation should not be used for installations without 3700 Series phones. For information on installations without 3700 Series phones see [Non-Provisioned Installation](#) on page 165.

For more information on provisioned installations, refer to the following sections:

1. [Unpacking the DECT Software](#) on page 45.
2. [Configuring IP Office](#) on page 47.
3. [Configuring the Master Base Station](#) on page 55.
4. [Configuring IP Slave Base Stations](#) on page 72.
5. [Mounting Base Stations](#) on page 80.
6. [Subscribing Phones](#) on page 82.

 **Note:**

The installation process and screen captures used in this document are for example only. Other methods and order of installed devices can be used once you become familiar with the installation process. For example, installing all of the slave base stations before installing the master base station.

IP Office Installation Requirements

- It is assumed that you are familiar with installation and configuration of IP Office systems.

Information

- Service user name and password for IP Office configuration access.
- Service user name and password for IP Office security settings access.
- IP Office IP address.
- Avaya IP Endpoint licenses.

Parts Required

- IP Office Release 10.1 software DVD or image of the IP Office Release 10.1 admin software.

Tools Required

- Programming PC with IP Office Manager application installed. You must have administrator rights on this PC to change its IP address settings unless it is functioning as a DHCP client.
- Software for zip file extraction.

IP Base Station Installation Requirements

Information

- DECT R4 SARI.
- Base Station IP Addresses.
- Detailed plans from the site survey indicating the intended base station locations, LAN sockets and if necessary power supply outlets.

Parts Required

- Base station

Includes:

- Base station.
- Two 3.5mm screws and two 6mm wall plugs suitable for wall mounting onto a solid wall (brick or similar).
- 1.2 metre (4 foot) LAN cable. If this is replaced with a longer cable the replacement should be a CAT5 Ethernet LAN cable.

! **Important:**

For DECT firmware 10.0 and higher, supported with IP Office Release 10.0 and higher, IPBS1 base stations are only supported as slave radio base stations . IPBS1 base stations are no longer supported in other roles, for example as master base stations. For systems being upgraded, any existing IPBS1 base station being used such other roles must first be replaced in that role with an IPBS2 or IPBL1.

- If using Power over Ethernet:
 - The base station supports Power over Ethernet, IEEE 802.3af, class 2.
- If not using Power over Ethernet:
 - Base station power supply unit.

Required if not using Power over Ethernet to power the base station. Note that the base station power supply units include an 8 metre (26 feet) cable from the PSU to the base station. Check that you have the correct type of power supply unit for the locale.

- BSX-0013: Europe (except United Kingdom).
- BSX-0014: United Kingdom.
- BSX-0015: USA/Canada.
- BSX-0016: Australia.
- Mains power outlet socket.
- LAN Socket.

Phone Subscription Requirements

Information

- Service user name and password for IP Office configuration.
- User names and extension numbers for the DECT phones.
- Phone IPEI numbers if using pre-configured installation mode.

Tools

- **IP Office Manager.**
- **Device Manager**

The software installed on each handset may need to be upgraded to match that supplied with the DECT R4 software. This is done using the Windows Device Manager software to upgrade phones via an advanced charger or using AIWS Device Manager to upgrade phones over the air.

- Web browser (Internet Explorer or Firefox are supported).

Unpacking the DECT Software

About this task

Before beginning installation of DECT R4, in addition to having IP Office Manager installed, unpack the DECT R4 software onto your programming PC.

DECT R4 is supported on a range of Avaya systems. However, for IP Office operation, only firmware specifically documented as having been tested and supported with IP Office should be used. Details of supported firmware will be included in IP Office Technical Bulletins and Technical Tips.

Procedure

1. On the programming PC, create a folder with a name indicating its purpose, for example **c:\IP_DECT_R4**.
2. Within the IP Office Administrator Application software (ie. the software from which IP Office Manager is installed), locate the folder **IPDECT**.

The folder contains a file `DECT R4.zip`. This is the file containing software for DECT R4. The file `IPDECT.zip` contains software for the previously supported IP DECT product and not for DECT R4

3. Copy the `DECT R4.zip` file to the folder created on the programming PC.
4. Using WinZip or a similar tool, extract the contents of the zip file into the folder, maintaining the directory structure of the zip files.

The set of files should appear similar to the following.

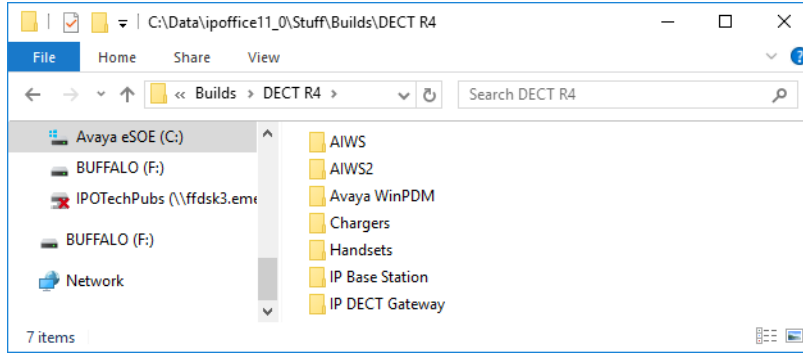

5. Check the software versions as follows:

- Open the `IP Base Station` folder. There are separate sub-folders for **IPBS1** and **IPBS2** base stations. Open each and note the software level shown as part of the `.bin` file filenames, there are separate files for the base station boot file and firmware file. All of the base stations in the installed system should run the same version of software.
- Open the `Handsets` folder and note the software level shown as part of the `.pkg` file filenames. The handsets in the system should be running this level of software or higher.
- Open the `IP DECT Gateway` folder and note the software level shown as part of the `.bin` filenames. These versions should be of the same level as the IP Base Stations. The IP DECT Gateway software versioning is in sync with the IP Base Station software versioning.

Device Management

During installation (provisioned or non-provisioned) it may be necessary to upgrade the software being used by the 3700 Series phones. This is done in one of two ways:

- **Windows Device Manager**

The Windows device manager application can be used to upgrade the software of phones placed in an advanced charger and connected to the PC via USB or LAN. If using this method, install the Windows Device Manager software and load the parameter definition files supplied with the DECT R4 software.

- **AIWS Device Management**

The AIWS device includes an integrated version of device manager that can be used to perform over the air upgrades. This method is only recommended for the maintenance of an existing system. For upgrades during the installation of a new system, Avaya recommends using Windows Device Manager.

For more information see [Upgrading Phone Software](#) on page 93

Configuring IP Office

The IP Office needs to be configured to allow communication between the IP Office and the DECT R4 system.

The IP Office configuration for a provisioned installation consists of the following procedures:

1. [Configuring Security Settings](#) on page 47
2. [Configuring the IP DECT Line](#) on page 50
3. [Enabling Subscription](#) on page 51
4. [Manually Creating Extensions](#) on page 85
5. [Adding Endpoint Licenses](#) on page 53
6. [Configuring a Source Number](#) on page 54

Configuring Security Settings

About this task

The provisioning connection between the IP Office control unit and the master base station uses the HTTP/HTTPS service configured in the IP Office system security settings.

- Important It is important to note that for new systems and system where the security settings have been defaulted:
- The IPDECTService service user used for provisioning is disabled by default.
- The TFTP Directory Read function used by handsets to display the IP Office system directory is off by default.

Procedure

1. In the IP Office Manager **View** menu, select **Advanced** .
2. Select **File | Advanced | Security Settings**.
3. From the discovery menu select the IP Office and click **OK**.
4. Enter the systems user name and password for the security service user login. They will be different from the name and password used for IP Office configuration access.
5. Select  **Services**.

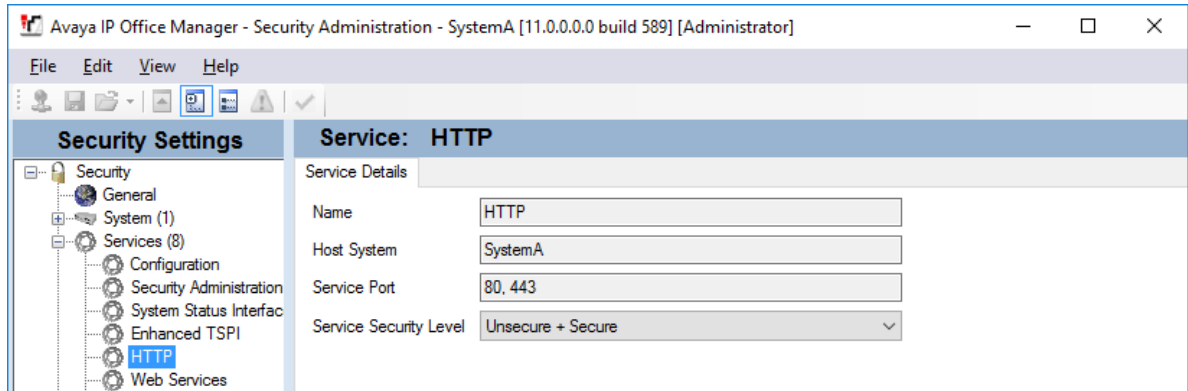

6. Select the **HTTP** service.
 - a. If the service is not present then the system has not been upgraded to run IP Office Release 8.0 software.
 - b. The HTTP service affects all HTTP connections provided by the IP Office system. Changing its setting will affect applications other than just the DECT R4. The only option that can be changed is the **Service Security Level**. The default is **Secure + Unsecure**, meaning both http and https can be used between the base station and IP Office.

- **Unsecure Only**

HTTP port 80 available and used for phone files, embedded file manager, system file upgrade, one-X Portal directory services, DECT R4 provisioning, IP Office Video Softphone provisioning.

- **Secure + Unsecure**

This mode (the default) allows both unsecure HTTP (see above) and secure HTTPS (see below) connections.

- **Secure, Low**

HTTPS port 443 available and used for DECT R4 provisioning, IP Office Video Softphone provisioning. This option allows secure access to that service using TLS, and demands weak (for example DES_40 + MD5) encryption and authentication or higher. The service's unsecured TCP port is disabled.

- **Secure, Medium**

This option allows secure access to that service using TLS, and demands moderate (for example DES_56 + SHA-1) encryption and authentication or higher. The service's unsecured TCP port is disabled.

- **Secure, High**

This option allows secure access to that service using TLS and demands strong (for example 3DES + SHA-1) encryption and authentication, or higher. In addition, a certificate is required from the client (usually IP Office Manager). For further details of security certificates see the IP Office Security Mode section in the IP Office Manager manual.

- Select **Rights Groups**. The list of groups should contain one called **IPDECT Group**. Select that group. If the group is not present in the list, click on the **new** entry icon to create the group.
7. Select the **HTTP** tab. Check that the option **DECT R4 Provisioning** and **Directory Read** are selected. Check that no other options are selected on any other tab.

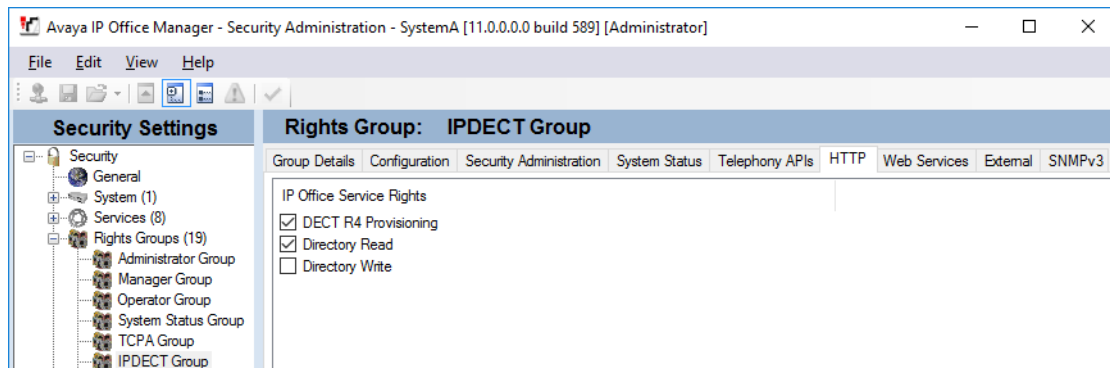

8. Select **Service Users**.
- Select the Service User **IPDectService**.

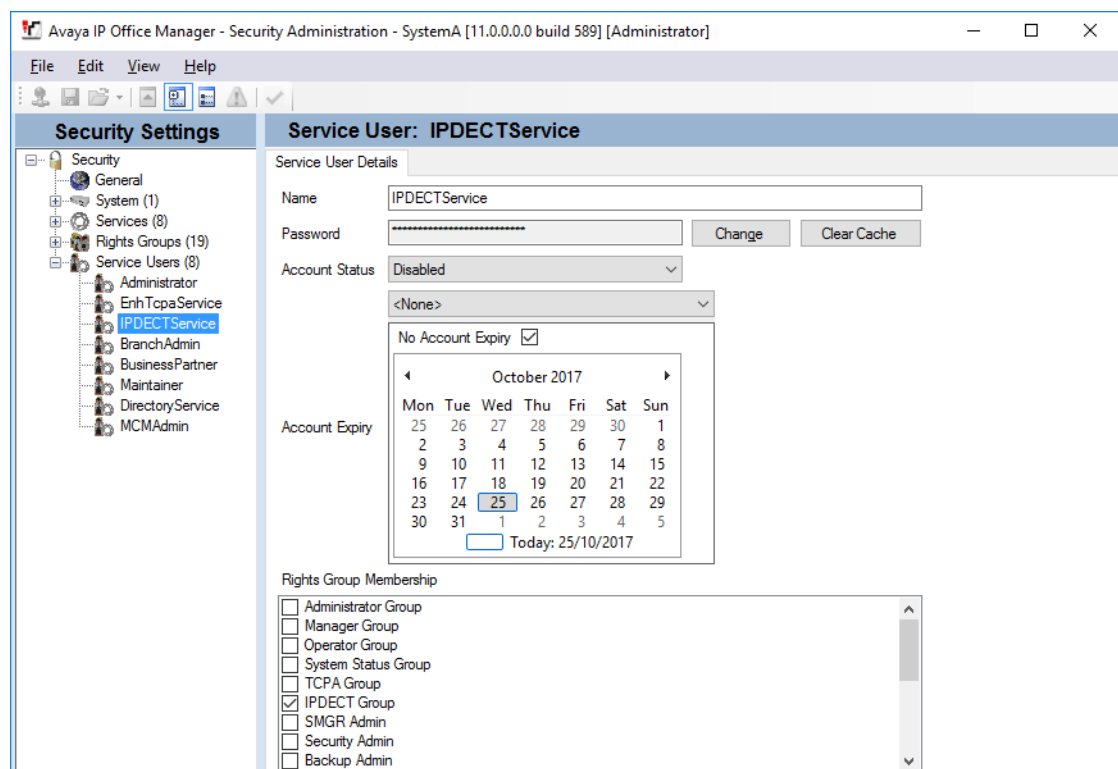

- In the **Rights Group Membership** list check that the user is set as a member of the **IPDECT Group**.
- Leave the **Account Status** as **Enabled** and the **Account Expiry** as **<None>**.

- d. Click on the  icon to save any changes you have made to the security settings.

*** Note:**

Avaya recommends changing the default password.

Creating IP DECT Lines



About this task

Use the following procedure to create an IP DECT line for traffic between the IP Office and the DECT R4 system. The line is configured with the IP address that will be assigned to the master base station. The IP Office configuration only requires a single IP DECT line.

*** Note:**

Adding or removing a line from the IP Office configuration requires the IP Office system to reboot. This will end all calls and services in progress.

Procedure

1. Using IP Office Manager, retrieve the configuration from the IP Office system.
2. Click on  **Line**. The list of existing lines is shown.
3. Click on the  icon and select **IP DECT Line**. The settings for an IP DECT line are displayed. If the option is greyed out then the configuration already contains an IP DECT line.
4. On the **Line** tab there are no adjustable settings. Once the system is installed and operational, this tab lists the DECT extensions.

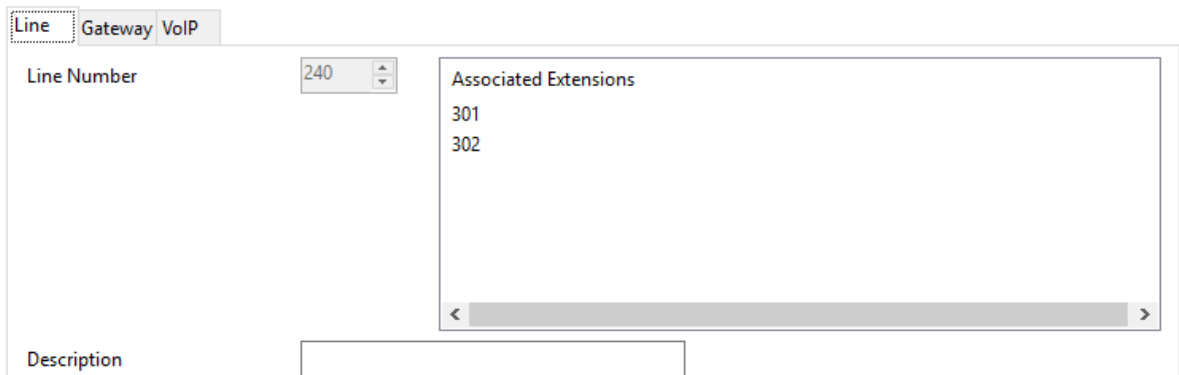

5. Select the **VoIP** tab. This table is used to set details of the master base station.

Line Gateway **VoIP**

Gateway IP Address 192 . 168 . 0 . 226

Standby IP Address 0 . 0 . 0 . 0

Codec Selection Custom

Unused

G.723.1 6K3 MP-MLQ

Selected

G.711 ULAW 64K
G.711 ALAW 64K
G.729(a) 8K CS-ACELP

TDM->IP Gain Default

IP->TDM Gain Default

VoIP Silence Suppression

Allow Direct Media Path

6. Set the **Gateway IP Address** to match the IP address that will be assigned to the master base station.
7. Set the **Codec Selection** to Custom and remove G.723 from the list of selected codecs.
8. Select the **Gateway** tab
9. Enter the **SARI/PARK** and **Authentication Code** into the appropriate fields. These values are used during the phone subscription process.

*** Note:**

To uniquely identify a single system (e.g. to generate a PARK code) one SARI certificate (Secondary Access Rights Identifier) is required per DECT installation to identify the system.

Enabling Subscription

About this task

The IP DECT line settings control how the DECT handsets subscribe. For information on subscribing phone handsets, see [Phone Subscription](#) on page 203

Procedure

1. The **Line** tab will list any DECT extensions already subscribed.

Provisioned Installation

Line Gateway VoIP

Line Number: 240

Associated Extensions:
301
302

Description:

2. Select the **Gateway** tab.

Line Gateway VoIP

Auto-Create Extension
 Auto-Create User

Enable DHCP Support

Boot File:

ADMM MAC Address:

VLAN ID:

Base Station Address List

--	--

Enable Provisioning

SARI/PARK:

Subscriptions:

Authentication Code:

Enable Resiliency

Status Enquiry Period:

Prioritize Primary

Supervision Timeout:

3. Change the Subscriptions mode to either **Auto-Create** or **Preconfigured**.

- **Auto-Create**

If you select this option, extension and user entries are automatically created in the IP Office configuration when the handsets are subscribed. Use this option for anonymous subscription. Ensure that no copies of the configuration are also open in Manager during subscription, as sending such a copy of the configuration back to the IP Office system will replace the subscriptions and require the handsets to be subscribed again.

Following any handset subscription, a new copy of the configuration should always be loaded in IP Office Manager if any other configuration changes are required.

- **Preconfigured**

If you select this option, handset will only be able to subscribe if they match an existing IP DECT extension in the IP Office configuration.

If the IP DECT line subscription setting is set to **Preconfigured**, you must manually add extension and user entries for each handset to the IP Office configuration. To manually add extension and user entries, see [Manually Creating Extensions](#) on page 85

4. Save the configuration back to the IP Office system.

Adding Licenses

About this task

Each IP DECT extension requires an Avaya IP Endpoint license. This applies even if the handset subscribed to the IP DECT R4 system is not an Avaya phone.

Phones without a license will still be able to subscribe and register but will be limited to making emergency calls only (calls that match an IP Office **Dial Emergency** short code). The associated user will be treated as if logged off. If a license becomes available, it will be assigned to any unlicensed DECT handsets first and then to any other unlicensed Avaya IP phone in the order that the phones registered.

- **Avaya IP Endpoint Licenses**

Licenses are added to the IP Office configuration and are based on a serial number unique to the system.

- Licenses are normally automatically assigned to extensions in order of registration. However, existing extensions can be configured to reserve a license. This ensures that they do not become unlicensed when newly added extensions manage to register first following a system reboot.

Reserving Licenses

About this task

Licenses are automatically assigned to extensions in order of registration. However existing extensions can reserve a license in order to ensure they do not become unlicensed when new extensions added to the system manage to register first following a system reboot.

Procedure

1. In IP Office Manager, select **Extension** and then select the DECT extension.
2. Select the **IP DECT** tab. Note, the appearance of this menu will vary depending on whether you are doing a provisioned or non-provisioned installation.

The screenshot shows the configuration page for an IP DECT extension. At the top, there are two tabs: 'Extn' and 'IP DECT', with 'IP DECT' being the active tab. Below the tabs, there are several configuration fields:

- DECT Line ID:** A dropdown menu showing '240 (190.168.42.224)'.
- Message Waiting Lamp Indication Type:** A dropdown menu showing 'On'.
- IPEI:** A text input field containing '0'.
- Use Handset Configuration:** An unchecked checkbox.
- Reserve Licence:** A dropdown menu showing 'Reserve Avaya IP endpoint licence'.

3. The **Reserve Avaya IP endpoint license** setting is used to reserve an existing license for the extension. The option is greyed out if the configuration does not have sufficient unreserved licenses remaining.
4. Repeat the process for any other extensions for which you want to reserve the license.
5. Save the configuration back to the IP Office system.

Configuring a Source Number

About this task

The **Source Number** setting ensures that the DECT system frequency remains correctly configured following a restart of the IP Office control unit. The **Source Number** string is required in the IP Office configuration only when the DECT R4 system frequency is set to either **North America** or **South America**.

Configure the **Source Number** string in IP Office Manager using the following procedure:

Procedure

1. In IP Office Manager, retrieve the IP Office configuration.
2. Navigate to the **NoUser** user.
3. Click the **Source Numbers** tab.
4. Click the **Add** button, enter the required Source Number, and click **OK**.
 - For installations in Europe, enter **IPBS_FR_EU**
 - For installations in North America, enter **IPBS_FR_NA**
 - For installations in South America, **IPBS_FR_SA**

5. Save the configuration back to the IP Office system.

Master Base Station Setup

Note:

If an IP DECT Gateway is being installed, Avaya recommends configuring the IP DECT Gateway as the master base station for the system. For information on installing an IP DECT Gateway, see [IP DECT Gateway Installation](#) on page 105.

Important:

For DECT firmware 10.0 and higher, supported with IP Office Release 10.0 and higher, IPBS1 base stations are only supported as slave radio base stations . IPBS1 base stations are no longer supported in other roles, for example as master base stations. For systems being upgraded, any existing IPBS1 base station being used such other roles must first be replaced in that role with an IPBS2 or IPBL1.

The DECT master base station configuration for a provision installation consists of the following steps:

1. [Defaulting the Base Station](#) on page 55.
2. [Accessing the Base Station Configuration](#) on page 56
3. [Setting the Base Station IP Address](#) on page 57
4. [Configuring the VLAN](#) on page 58
5. [Updating the Base Station Software](#) on page 60
6. [Selecting Administration Mode](#) on page 62
7. [Selecting Master Mode](#) on page 63.
8. [Setting the DECT Password](#) on page 64
9. [Setting the Time Zone](#) on page 65.
10. [Enabling Provisioning](#) on page 65.
11. [Enabling HTTPS and Security Certificates in the Web Interface](#) on page 66.
12. [Adding the Radio Connections](#) on page 68.
13. [Integrating the Phonebook](#) on page 68

Defaulting the Base Station

About this task

This process will default a base station or IP DECT Gateway, erasing its configuration. After the unit restarts it will default to the IP address 192.168.0.1/255.255.255.0.

*** Note:**

The following instructions assume you are installing an IPBS2, which has one LED lamp. The IPBS1 has two LED lamps. For more information on the base station LEDs and what their statuses indicate, see [Base Station Status Lamps](#) on page 14.

Procedure

1. With only the power supply connected, switch the base station on.
The LED on the base station flashes red if no Ethernet is detected.
2. Wait approximately five seconds.
3. Press and hold the **Reset** button on the base station for approximately 10 seconds..
The LED on the base station will change to a quick flash, then the LED will go out, and then the LED returns to a slower flash.
4. Release the Reset button and wait for the base station to reset.
The LED should turn back on to solid amber.
5. Quickly press the **Reset** button once.
The base station reboots with default settings. The default IP is 192.168.0.1, with DHCP on, but not active. If you wish to activate DHCP reset the base station again.

*** Note:**

Avaya recommends disabling the DHCP on the base station and configuring the system with static IP addresses. For information on disabling DHCP on the base station, see [Set the Base Station IP Address](#) on page 57.

Accessing the Base Station Configuration

Procedure

Depending on whether DHCP is being used or not:

- a. Connect the base station to the network or PC using the LAN cable.
- b. If connected directly to the base station, change your programming PC's network address to 192.168.0.200 with subnet mask 255.255.255.0.
- c. If both your PC and the base station are connected to a LAN network with DHCP server, ensure your PC is set to act as a DHCP client or has a fixed address that is valid on the network.
- d. Start your web browser and enter the http:// or https:// followed by the IP address of the base station. The default IP address is 192.168.0.1. If a security certificate warning is displayed, select to continue to this website.
- e. The base station responds with its login menu.



IP-DECT Base Station

Select login

- f. Select **System administration**. Enter the default user name (**admin**) and password (**changeme**) and click **Login**.
- g. A summary of the current logins is displayed. Click **OK**.
- h. The configuration menu for the base station is displayed.

Configuration	Info	Admin	EULA	Logout
General				
LAN	Version IPBS[10.0.5], Bootcode[10.0.5], Hardware[IPBS1-Y4/PD] Serial Number 09AD15300066 MAC Address (LAN) 00-01-3e-01-6f-9c DRAM 32 MB FLASH 8 MB Coder 8 Channels of G.711,G.729,G.723 SNTP Server 192.168.0.214 Time **:*:* **:* Uptime 0d 1h 38m 42s			
Administration				
Backup				
Update				
Diagnostics				
Reset				

- i. Note the software levels shown in the **General | Info** menu. These will determine if the base station software needs to be upgraded.

*** Note:**

Compact Base Stations have advanced menu options hidden by default. To enable or disable Advanced Administration menus, see [Select Administration Mode](#) on page 62 .

Setting the Base Station IP Address

About this task

During initial installation the IP address of a base station defaults to 192.168.0.1. The process below can be used to change the DHCP mode and IP address of a base station.

Procedure

1. From the base station configuration window, in the left-hand column, select **LAN**.
2. Select the **IP** tab.

- a. Enter the required **IP Address** and **Network Mask** for the base station. The other settings are optional.
- b. Click **OK**.

*** Note:**

The menu will prompt you with the message **Reset Required**. Do not click this or reset the base station at this stage.

- c. Select the **DHCP** tab.

- d. Using the **Mode** drop-down, select **Disabled**.
- e. Click **OK**.
- f. Select **Reset** and then select the **Reset** tab.
- g. Click **OK**.
- h. Depending on your base station, wait for the LED to return to solid blue or solid green.
- i. Log in again using the new IP address.

Configuring a Virtual Local Area Network (VLAN)

Both the IPBS1 and IPBS2 support VLAN capability. Note that the VLAN ID must be the same as the ID configured in the IPBS/IPBL, otherwise access to the IPBS/IPBL will not be possible.

On systems that do not support VLAN tagging (IEEE 802.1q), proceed to [Update the Base Station Software](#) on page 60. Note that VLAN configuration requires the **Advanced Administration** menu mode to be enabled.

Note: If "VLAN = 0", the Quality of Service (QoS) is inactive according to 802.1q. You should also avoid "VLAN = 1" as it is often used as a default VLAN setting.

Configuring a VLAN

About this task

Use the following procedure to configure a VLAN ID on a systems comprised of switches and endpoints that support VLAN tagging (IEEE 802.1q).

Procedure

1. Under the **Configuration** menu, navigate to **LAN** and then select the **VLAN** tab.

2. In the **ID** field, enter the parameter configured in the IPBS/IPBL.
3. Click **OK**.

Viewing LAN Statistics

About this task

To view statistics of LAN events:

- On the IPBS, select **LAN > Statistics**.
- On the IPBL, select **LAN1 > Statistics**.

Press **Clear** to reset the ethernet statistics counters. You may need to scroll down to view the **Clear** button.

Deactivating LAN Port (IPBL only)

About this task

The IP DECT Gateway (IPBL) has two LAN ports. The LAN2 port is used for administration only. If necessary, you can deactivate that port.

Procedure

1. Select **LAN2 > IP**.

Note: The LAN2 port is for administration only. It is typically the port you want to deactivate.

Configuration	System	Suppl. Serv.	Master	Trunks	Radio	Radio config	PARI	SARI	Air Sync	Logout
General										
LAN										
IP										
LDAP										
DECT										
VoIP										
Unite										
Services										
Administration										
Users										
Device Overview										
DECT Sync										
Traffic										

Active Settings

IP Address: 192.168.1.1

Network Mask: 255.255.255.0

Default Gateway: 172.29.40.254

DNS Server:

Alt. DNS Server:

Check ARP:

Disable:

No IP protocol data will be sent/received via this interface

OK Cancel

2. Select the **Disable** checkbox.
3. Click **OK**.

Updating the Base Station Software

About this task

The base station may need to be upgraded to match the software version supplied for use with the IP Office. The base station software consists of two parts, a firmware file and a boot file. All base stations in a DECT system should use the same version of software.

Procedure

1. Browse into the base station configuration and note the software levels shown by the **Version** line.

Configuration	Info	Admin	EULA	Logout
General				
LAN				
Administration				
Backup				
Update				
Diagnostics				
Reset				

Version IPBS[10.0.5], Bootcode[10.0.5], Hardware[IPBS1-Y4/PD]

Serial Number 09AD15300066

MAC Address (LAN) 00-01-3e-01-6f-9c

DRAM 32 MB

FLASH 8 MB

Coder 8 Channels of G.711,G.729,G.723

Sntp Server 192.168.0.214

Time ** ** ** **

Uptime 0d 1h 38m 42s

2. Check that these match the versions supplied with the IP Office administration software.

Ensure that you are checking against the correct folder for an IPBS1 or IPBS2 base station. If they do not match, you must upgrade the base station.

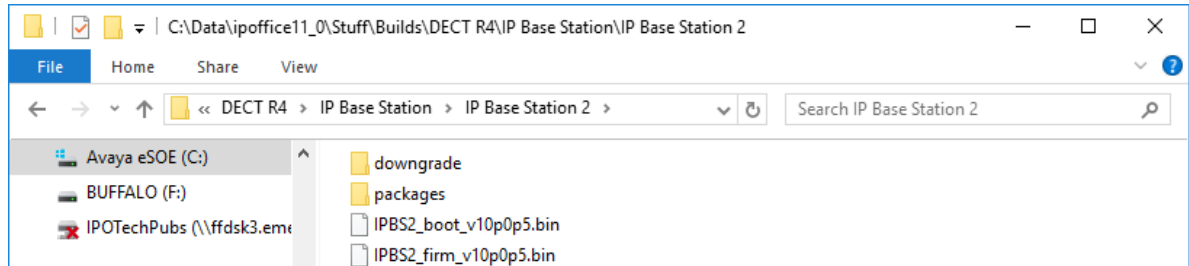

If both software files need to be upgraded, the boot file should be upgraded first.

3. In the left-hand column, under the **Administration** menu, select **Update** and then select the **Boot** tab.

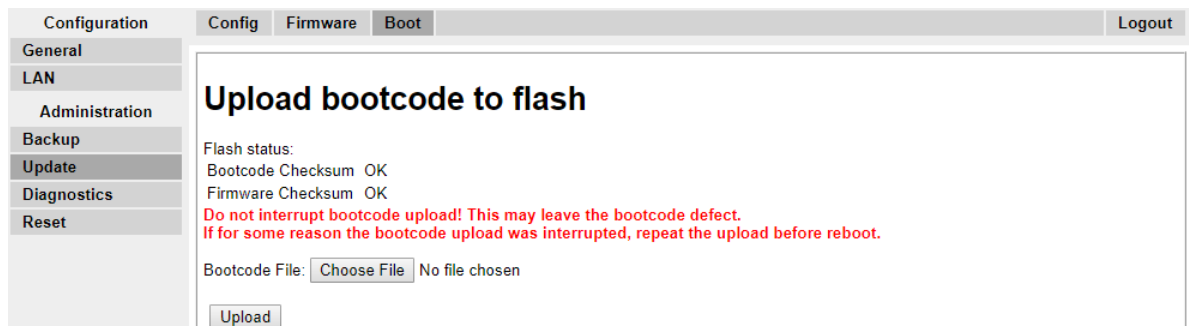

4. Click on the **Browse** button and browse to the **IP Base Station 2** sub-folder of the IP DECT R4 software.
5. Select the appropriate boot file for the upgrade you are performing.
6. Click **OK**.
7. Click on the **Upload** button.

The browser shows the progress of the upload and upgrade. It will indicate when the process has been completed.



8. If necessary, repeat the process to upgrade remaining base stations.
9. To upgrade the base station firmware file, select **Update** and then select the **Firmware** tab.

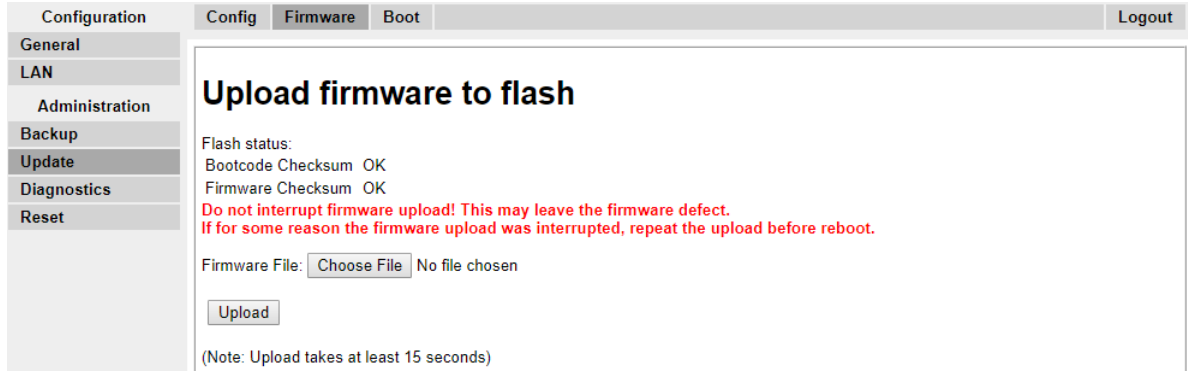

10. Click on the **Browse** button and browse to the **IP Base Station** sub-folder of the IP DECT R4 software you previously extracted onto the programming PC.
11. Select the appropriate firmware file for the upgrade you are performing,
12. Click **OK**.
13. Click on the **Upload** button.

The browser shows the progress of the upload and upgrade. It will indicate when the process has been completed.

14. Click on **Reset**.
15. Log in again. The **General | Info** tab should now list the new firmware.

If necessary, repeat the process for the remaining base stations using the **Update | Firmware** menu.

If necessary, update the base station firmware for base stations that will be connected to an IP DECT Gateway using the **Update | RFPs** menu.

Selecting Administration Mode

About this task

On Standard Base Stations, all base station menus and menu options are visible by default, including numerous settings that are not applicable for IP Office operation. Compact Base Stations have advanced options hidden by default. This option is not supported on an IP DECT Gateway.

To enable or disable the advanced administration mode, use the following procedure.

Procedure

1. Select **General | Admin**.

Configuration	Info	Admin	EULA	Logout
General				
LAN				
Administration				
Backup				
Update				
Diagnostics				
Reset				

Local Admin

Device Name

User Name

Password (A maximum of 15 characters are allowed.)

Confirm Password

Login Banner

Password Policy

Minimum length

Number of character types

Number of previous passwords not allowed

Do not allow repeated characters

Do not allow sequential characters

Administration Mode

Show Advanced Options

OK Cancel

2. Enable or disable the **Show Advanced Options** checkbox as desired.

Administration Mode

Show Advanced Options

3. Click **OK**.

Selecting Master Mode

About this task

You must configure a base station to act as a master base station and configure the master for the type of telephone system it will be operating with.

Procedure

1. Select **DECT** and then select the **Master** tab.

Configuration	System	Suppl. Serv.	Master	Trunks	Radio	Radio config	PARI	SARI	Air Sync	Logout
General										
LAN										
IP										
LDAP										
DECT										

Mode

OK Cancel

2. Change the **Mode** to **Active** and click **OK**. A warning is displayed if the DECT password has not been set. For information on setting the DECT password, see [Set the DECT Password](#) on page 64.
3. Select the **Reset** in the configuration column.
4. Reset the base station.
5. Select **DECT** and then select the **Master** tab again.

Configuration	System	Suppl. Serv.	Master	Trunks	Radio	Radio config	PARI	SARI	Air Sync	Logout
General										
LAN										
IP										
LDAP										
DECT										
VoIP										
Unite										
Services										
Administration										
Users										
Device Overview										
DECT Sync										
Traffic										

Mode: Active

IP-PBX

PBX: IPO

PBX Resiliency:

Protocol: H.323/XMobile

ARS Prefix:

International CPN Prefix:

National CPN Prefix:

OK Cancel

reset required

6. Change the **PBX** setting to **IPO** and click **OK**.
7. Select **Reset** in the configuration column.
8. Reset the base station.

Setting the DECT Password

About this task

The DECT system name and password are used by other base stations to connect to the master. The name also appears in other menus and on phone displays.

Procedure

1. Select **DECT** and then select the **System** tab.

Configuration	System	Suppl. Serv.	Master	Trunks	Radio	Radio config	PARI	SARI	Air Sync	Logout
General										
LAN										
IP										
LDAP										
DECT										
VoIP										
Unite										
Services										
Administration										
Users										
Device Overview										
DECT Sync										
Traffic										
Backup										
Update										
Diagnostics										
Reset										

System Name: IPBS2

Password:

Confirm Password:

Subscriptions: With System AC

Authentication Code: 50428950

Default Language: English

Frequency: 1880-1900 MHz (Europe)

Enabled Carriers: 9 8 7 6 5 4 3 2 1 0

Early Encryption:

Coder: G729A Frame (ms) 30 Exclusive SC

Secure RTP Key Exchange: No encryption

OK Cancel

reset required

2. Enter and confirm the password you want to use.

3. The **Subscriptions** and **Authentication Code** fields should not be adjusted. These will be set by the IP Office once the base station is in provisioning mode.
4. Check that the DECT **Frequency** field is set correctly for your location.
5. Click **OK**.

Setting the Time Zone

About this task

During a provisioned installation, Network Time Protocol (NTP) settings are all greyed out as the IP Office is automatically set as the time server. If you do not set the time zone prior to provisioning, the time and date on all the sets will be incorrect.

Procedure

1. Select **General** and then select the **NTP** tab.

Configuration	Info	Admin	NTP	Kerberos Server	Certificates	EULA	Logout
General							
LAN							
IP							
LDAP							
DECT							
VoIP							
Unite							
Services							
Administration							
Users							
Device Overview							

	Active Settings
Time Server	192.168.0.50
Alt. Time Server	
Interval [min]	60
Timezone	Europe - Central European Time (UTC+1)
String	CET-1CEST-2,M3.5.0/2,M10.5.0/3
Current Server	192.168.0.50 -> 192.168.0.50
Last Sync	

OK Cancel

2. Using the **Timezone** drop-down menu, select the appropriate time zone for your area.
3. Click **OK**.

Enabling Provisioning

About this task

You can now configure the master base station for IP Office provisioning. Once you have enabled provisioning, several fields of the base station configuration will be set by the IP Office system. Other fields are greyed out and or automatically set to the values required for IP Office operation.

Before enabling IP Office provisioning, ensure that you configure the time zone. Otherwise, the time and date on all sets will be incorrect, as the IP Office is automatically set as the time server.

Procedure

1. Select **Services** and then select the **Provisioning** tab. This tab is only available when the base station's **Master** setting is **Active** and the **PBX** setting is set to **IPO** (see [Select Master Mode](#) on page 63).

Configuration	Update	Logging	HTTP	HTTP Client	SNMP	Provisioning	Phonebook	Logout
General								
LAN								
IP								
LDAP								
DECT								
VoIP								
Unite								
Services								
Administration								
Users								
Device Overview								
DECT Sync								
Traffic								
Backup								
Update								
Diagnostics								
Reset								

Current view	Primary ▾
Enable	<input checked="" type="checkbox"/>
Use HTTPS	<input checked="" type="checkbox"/>
PBX IP Address	<input type="text" value="192.168.0.210"/>
General HTTP settings	
Base directory	<input type="text" value="/system/ipdect/"/>
User Name	<input type="text" value="IPDECTService"/>
Password	<input type="password" value="*****"/>
Update service sub directory and file name	
Command File	<input type="text" value="update_service"/>
Provisioning sub directory and file name	
System data	<input type="text" value="system_data"/>
User data	<input "="" type="text" value="extension_data?id="/>
Status	Inactive
<input type="button" value="OK"/> <input type="button" value="Cancel"/>	

2. Select the **Enable** option.
3. The IP Office security settings control whether HTTPS is supported between the IP Office control unit and the master base station (by default it is supported). To configure the IP DECT to use both self-signed certificates and approved certificates from a trusted location, enable the **Use HTTPS** checkbox and refer to [Security Settings](#) on page 47.
4. Set the **PBX IP Address** to match the IP Office system on which the IP DECT line was configured.
5. In the User Name and Password fields, set the details to match the IP Office system's service user configured for IP DECT. See [Security Settings](#) on page 47.
6. Click **OK**.
7. Reset the base station.
8. Select the **Services | Provisioning** tab again. The Status should have changed to **Connected**. If not, a user name/password mismatch may have caused the IP Office service user account to become disabled, check the settings and re-enable the user.
9. Select **DECT | SARI**. The value of the SARI entered into the IP Office configuration should now also be visible in the base station configuration.
10. Select **DECT | System**.

Enabling HTTPS and Security Certificates in the Web Interface

About this task

Depending on your site configuration, you may need to enable provisioning in the device configuration so that the IP DECT allows both self-signed certificates and approved certificates

from a trusted location. You can also configure this option in IP Office Manager. See [Enabling HTTPS and Security Certificates in IP Office Manager](#) on page 47.

Procedure

1. Begin by enabling the advanced view in the Web Interface. Refer to [Select Administration Mode](#) on page 62.
2. Ensure that HTTPS provisioning is enabled.
3. Save the configuration and reset the device.
4. Select **General | Certificates** and wait to see the certificate from IP Office appear in the **Not trusted** list.

Subject	Issuer	Not before	Not after	Download
<input type="checkbox"/> 00-01-3e-12-86-81	00-01-3e-12-86-81	01.01.2000	31.12.2049	PEM DER

5. Under **Rejected Certificates**, select the desired certificate from the **Not trusted** list and press the **Trust** button.

The certificate should now appear in the **Trust List** section. No reset is required.

Adding Radio Connections

About this task

Each base station has a radio interface that must connect with the master base station. That includes the master base station’s own radio interface.

Procedure

1. Select **Device Overview** and then select the **Radios** tab.

2. The list shows those base stations the master can detect. Click **Add**.
3. On the popup window that appears, click **OK**.
4. Wait for the **Radios** tab to refresh. Note that this can take a couple of minutes.

Phonebook Integration

About this task

In a provisioned installation, the phonebook settings are automatically set by the IP Office system. However, use of the IP Office users, groups and directory as part of the DECT phone directory still

needs to be enabled if required. If not enabled, the Central Phonebook functions on the DECT phones will not work.

For DECT systems using an AIWS, central phone book provisioning is done via the AIWS. (see [Enable Base Station AIWS Connection](#) on page 161).

Procedure

1. Select **Services**.
2. Select **Phonebook**.
3. Select **Enable**.

The screenshot shows a web-based configuration interface. On the left is a vertical sidebar with the following menu items: Configuration, Provisioning, Phonebook, and Logout. The main content area is titled 'Phonebook' and contains the following settings:

- An 'Enable' checkbox.
- A 'General Settings' section with:
 - 'Search Direction Numbers' set to 'Right to left' (dropdown menu).
 - 'Phonebook Number' set to '999999' (text input field).
- A 'TFTP Settings' section with:
 - 'Server IP Address' set to '192.168.0.210' (text input field).
- 'OK' and 'Cancel' buttons at the bottom.

4. Click **OK**.

Performing an RFP Scan

About this task

The following processes are only required if the DECT system is operating in the same area as other DECT systems.

The Primary Access Rights Identifier (PARI) is a part of the IPBS broadcast identity, which uniquely identifies each DECT system. This PARI is automatically assigned to each master in the system. However, if more than one DECT system operates within the same coverage area, each system need to have a unique PARI assigned in order to differentiate the systems.

To see the occupied system IDs of other Avaya IP-DECT systems within the coverage area, perform an RFP scan using the following procedure:

Procedure

1. Select **Diagnostics**
2. Select **RFP Scan**
3. Click **Start Scanning**

*** Note:**

Executing an RFP scan will terminate all calls on the IPBS.

Entering the PARI

About this task

The following processes are only required if the DECT system is operating in the same area as other DECT systems. Following a RFP scan, ensure that the master base station has a unique Primary Access Rights Identifier (PARI) to identify it and the DECT system.

Procedure

1. In the left-hand panel select **DECT**. Select the **PARI** tab.

The screenshot shows a configuration window with a left-hand navigation pane and a main content area. The left-hand pane has a 'Configuration' header and several sub-items: 'General', 'LAN', 'IP', 'LDAP', and 'DECT'. The 'DECT' item is highlighted. The main content area has a horizontal tab bar with 'System', 'Suppl. Serv.', 'Master', 'Trunks', 'Radio', 'Radio config', 'PARI', 'SARI', 'Air Sync', and 'Logout'. The 'PARI' tab is selected. Below the tab bar is a form with a 'System ID' label and a text input field containing the number '30'. Below the input field are two buttons: 'OK' and 'Cancel'.

2. Enter a value between 1 and 35. This value must be unique from any other DECT R4 master base station in the area.
3. Click **OK**.

Configuring Air Sync

About this task

The following process is only required if the DECT system is operating in the same area as other DECT systems or the position of the master base station means it cannot be used as the air synchron master for all the other base stations.

Base stations in the DECT R4 system need to be synchronized with each other. This can be done with a signal as low as -90dB between base stations.

One base station is assigned as the 'air sync master', typically the master base station. Each other base station can sync directly with it or indirectly via a synchronization chain. However, it is preferable that the number of synchronization 'hops' between any particular base station and its air sync master base station is kept as low as possible. To help achieve this it is recommended that the air sync master is placed centrally within the set of base stations.

Where possible, each base station should be placed within synchronization range of more than one base station, which allows the base stations to maintain synchronization should one base station fail or be switched off for maintenance. The process of synchronizing by the shortest route to the air sync master when in synchronization range of multiple base stations is automatic.

Procedure

1. In the left-hand panel, select **DECT**. Select the **Air Sync** tab.

Configuration	System	Suppl. Serv.	Master	Trunks	Radio	Radio config	PARI	SARI	Air Sync	Logout
General										
LAN										
IP										
LDAP										
DECT										
VoIP										
Unite										
Services										
Administration										
Users										
Device Overview										

Sync Mode:

Reference RFPI:

Alternative reference RFPI:

Sync Region:

Action at reference sync failure:

Resynchronize on command

Resynchronize every day at

Resynchronize every at

2. Set the **Sync Mode** to **Master**.
3. Click **OK**.

Advanced Scenario: Separated Locations

In most scenarios, the master base station (Standard or Compact) is also used as the air sync master for all the other slave base stations and that is the scenario documented in this manual. However, in scenarios where you have base stations in separate locations that are not within synchronization range of each other, it is permissible to assign separate air sync masters in each location. However, there must be absolutely no overlap (<-90dB) between the separate groups of base stations. Any overlap will cause frequent loss of synchronization.

Having separate locations, each with its own synchronization, is done through the settings on the **DECT | Air Sync** tab of each base station. For each location, set the same **Sync Region** number for all the base stations at that location, using a different number for each location. In addition, use the **Sync Mode** drop-down menu to configure one of the base stations in each location as the **Master** base station.

* Note:

In deployments in mixed systems with IP Base Stations and IP-DECT Gateways, the IP-DECT Gateways need to be physically interconnected for the purpose of radio synchronization. When configuring an IP-DECT Gateway as an air sync master, use sync region 0. All other base stations should be configured as sync slaves. Systems with IPBS in sync regions that have only IPBS should use non-zero sync region number(s) and be configured with at least one sync master with the remaining IPBSs configured as sync slaves.

Configuring Air Sync in Separated Locations Procedure

1. For each base station in the system, configure a **Sync Region** number under the **DECT | Air Sync** tab in the Device Manager and click **OK**.

All the base stations in a single region should contain the same **Sync Region** number, but each Sync Region must have its own unique number. By default, **Sync Region = 0**, which means that no region is defined.

- For each new Sync Region created, configure one base station as the **Master** using the **Sync Mode** drop-down menu and click **OK**.

You must configure at least one master base station per region.

The screenshot shows a configuration window with a sidebar on the left containing menu items: Configuration, System, Suppl. Serv., Master, Trunks, Radio, Radio config, PARI, SARI, Air Sync, and Logout. The 'Master' tab is active. The main area contains the following fields and options:

- Sync Mode:** A dropdown menu set to 'Master'.
- Reference RFPI:** An empty text input field.
- Alternative reference RFPI:** An empty text input field.
- Sync Region:** A text input field containing the number '1'.
- Action at reference sync failure:** Three radio button options:
 - Resynchronize on command
 - Resynchronize every day at 00:00
 - Resynchronize every Sunday at 00:00

At the bottom of the window are 'OK' and 'Cancel' buttons.

IP Slave Base Station Setup

Once you have completed the setup of the DECT master base station, proceed to configure the slave base stations for the system.

The slave base station configuration for a provision installation consists of the following steps:

- [Defaulting the Base Station](#) on page 72
- [Accessing the Base Station Configuration](#) on page 73
- [Setting the Base Station IP Address](#) on page 74
- [Updating the Base Station Software](#) on page 75
- [Set the Base Station to Slave Mode](#) on page 191
- [Registering the Slave Base Station](#) on page 79

Defaulting the Base Station

About this task

This process will default a base station or IP DECT Gateway, erasing its configuration. After the unit restarts it will default to the IP address 192.168.0.1/255.255.255.0.

*** Note:**

The following instructions assume you are installing an IPBS2, which has one LED lamp. The IPBS1 has two LED lamps. For more information on the base station LEDs and what their statuses indicate, see [Base Station Status Lamps](#) on page 14.

Procedure

1. With only the power supply connected, switch the base station on.
The LED on the base station flashes red if no Ethernet is detected.
2. Wait approximately five seconds.
3. Press and hold the **Reset** button on the base station for approximately 10 seconds..
The LED on the base station will change to a quick flash, then the LED will go out, and then the LED returns to a slower flash.
4. Release the Reset button and wait for the base station to reset.
The LED should turn back on to solid amber.
5. Quickly press the **Reset** button once.
The base station reboots with default settings. The default IP is 192.168.0.1, with DHCP on, but not active. If you wish to activate DHCP reset the base station again.

*** Note:**

Avaya recommends disabling the DHCP on the base station and configuring the system with static IP addresses. For information on disabling DHCP on the base station, see [Set the Base Station IP Address](#) on page 57.

Accessing the Base Station Configuration

Procedure

Depending on whether DHCP is being used or not:

- a. Connect the base station to the network or PC using the LAN cable.
- b. If connected directly to the base station, change your programming PC's network address to 192.168.0.200 with subnet mask 255.255.255.0.
- c. If both your PC and the base station are connected to a LAN network with DHCP server, ensure your PC is set to act as a DHCP client or has a fixed address that is valid on the network.
- d. Start your web browser and enter the http:// or https:// followed by the IP address of the base station. The default IP address is 192.168.0.1. If a security certificate warning is displayed, select to continue to this website.
- e. The base station responds with its login menu.



IP-DECT Base Station

Select login System Administration ▾

- f. Select **System administration**. Enter the default user name (**admin**) and password (**changeme**) and click **Login**.
- g. A summary of the current logins is displayed. Click **OK**.
- h. The configuration menu for the base station is displayed.

Configuration	Info	Admin	EULA	Logout
General				
LAN				
Administration				
Backup				
Update				
Diagnostics				
Reset				
	Version	IPBS[10.0.5], Bootcode[10.0.5], Hardware[IPBS1-Y4/PD]		
	Serial Number	09AD15300066		
	MAC Address (LAN)	00-01-3e-01-6f-9c		
	DRAM	32 MB		
	FLASH	8 MB		
	Coder	8 Channels of G.711,G.729,G.723		
	SNTP Server	192.168.0.214		
	Time	**** **..**		
	Uptime	0d 1h 38m 42s		

- i. Note the software levels shown in the **General | Info** menu. These will determine if the base station software needs to be upgraded.

*** Note:**

Compact Base Stations have advanced menu options hidden by default. To enable or disable Advanced Administration menus, see [Select Administration Mode](#) on page 62 .

Setting the Base Station IP Address

About this task

During initial installation the IP address of a base station defaults to 192.168.0.1. The process below can be used to change the DHCP mode and IP address of a base station.

Procedure

1. From the base station configuration window, in the left-hand column, select **LAN**.
2. Select the **IP** tab.

Configuration	DHCP	IP	802.1X	LLDP	Logout
General					
LAN					
Administration					
Backup					
Update					
Diagnostics					
Reset					

	Active Settings
IP Address	192.168.0.226
Network Mask	255.255.255.0
Default Gateway	192.168.0.1
DNS Server	
Alt. DNS Server	
Check ARP	<input type="checkbox"/>

- a. Enter the required **IP Address** and **Network Mask** for the base station. The other settings are optional.
- b. Click **OK**.

*** Note:**

The menu will prompt you with the message **Reset Required**. Do not click this or reset the base station at this stage.

- c. Select the **DHCP** tab.

Configuration	DHCP	IP	802.1X	LLDP	Logout
General					
LAN					
Administration					
Backup					

Mode disabled Currently - disabled

- d. Using the **Mode** drop-down, select **Disabled**.
- e. Click **OK**.
- f. Select **Reset** and then select the **Reset** tab.
- g. Click **OK**.
- h. Depending on your base station, wait for the LED to return to solid blue or solid green.
- i. Log in again using the new IP address.

Updating the Base Station Software

About this task

The base station may need to be upgraded to match the software version supplied for use with the IP Office. The base station software consists of two parts, a firmware file and a boot file. All base stations in a DECT system should use the same version of software.

Procedure

1. Browse into the base station configuration and note the software levels shown by the **Version** line.

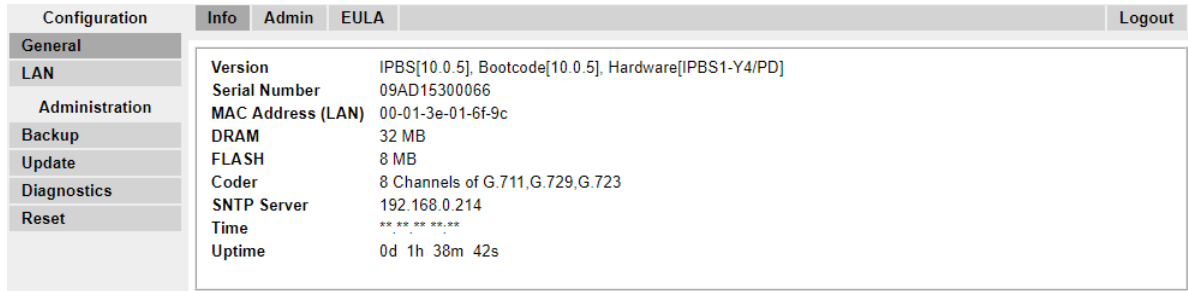

2. Check that these match the versions supplied with the IP Office administration software.

Ensure that you are checking against the correct folder for an IPBS1 or IPBS2 base station. If they do not match, you must upgrade the base station.

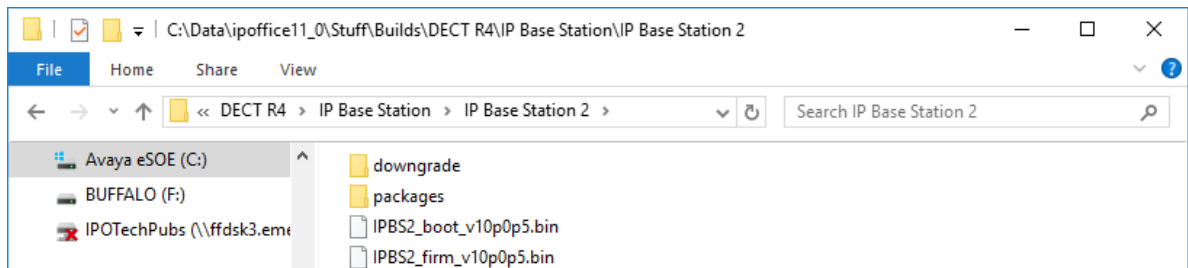

If both software files need to be upgraded, the boot file should be upgraded first.

3. In the left-hand column, under the **Administration** menu, select **Update** and then select the **Boot** tab.



4. Click on the **Browse** button and browse to the **IP Base Station 2** sub-folder of the IP DECT R4 software.
5. Select the appropriate boot file for the upgrade you are performing.
6. Click **OK**.
7. Click on the **Upload** button.

The browser shows the progress of the upload and upgrade. It will indicate when the process has been completed.



8. If necessary, repeat the process to upgrade remaining base stations.
9. To upgrade the base station firmware file, select **Update** and then select the **Firmware** tab.

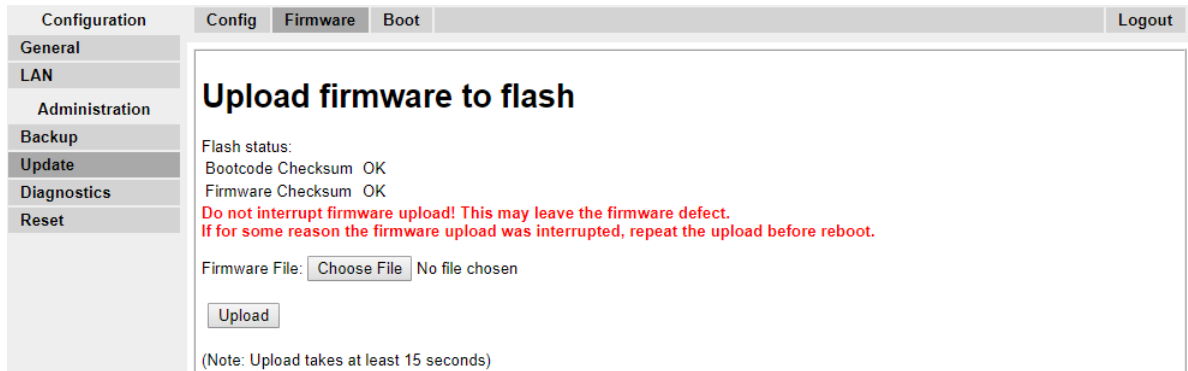

10. Click on the **Browse** button and browse to the **IP Base Station** sub-folder of the IP DECT R4 software you previously extracted onto the programming PC.
11. Select the appropriate firmware file for the upgrade you are performing,
12. Click **OK**.
13. Click on the **Upload** button.

The browser shows the progress of the upload and upgrade. It will indicate when the process has been completed.

14. Click on **Reset**.
15. Log in again. The **General | Info** tab should now list the new firmware.

If necessary, repeat the process for the remaining base stations using the **Update | Firmware** menu.

If necessary, update the base station firmware for base stations that will be connected to an IP DECT Gateway using the **Update | RFPs** menu.

Setting a Base Station to Slave Mode

About this task

There can be only one master base station in the IP Office DECT R4 system. In this process we check that the base station is not set to act as a master and then configure its radio settings to access the master base station.

Procedure

1. In the left-hand column, select **DECT**. Select the **Master** tab.

Configuration | System | Suppl. Serv. | **Master** | Trunks | Radio | Radio config | PARI | SARI | Air Sync | Logout

General | LAN | IP | LDAP | DECT

Mode: Off

OK Cancel

2. Check that the **Mode** is set to **Off**.
3. Click **OK**.
4. Select the **Radio** tab.

Configuration | System | Suppl. Serv. | Master | Trunks | **Radio** | Radio config | PARI | SARI | Air Sync | Logout

General | LAN | IP | LDAP | DECT | VoIP | Unite | Services | Administration | Users | Device Overview | DECT Sync | Traffic | Backup | Update | Diagnostics | Reset

Disable

Master

Name: IPBS2

Password:

Master IP Address: 192.168.0.227

Alt. Master IP Address: 192.168.0.226

Status: Connected to Master 192.168.0.227

Max RTP Streams

Number of Streams:

Received Configuration

SARI: 31100243777703

RFPI: 9014AC1008

Subscriptions: Disable

Authentication Code

Default Language: English

Frequency: 1920-1930 MHz (North America)

Enabled Carriers: 23 24 25 26 27 (all checked)

Early Encryption: disabled

ICE: enabled

Coder: 20 ms

Secure RTP Key Exchange: No encryption

OK Cancel

5. Set the following details:

- **Name**

Set this to match the **System Name** set on the master base station's **DECT | System** tab.

- **Password**

Set this to match the **Password** set on the master base station's **DECT | System** tab.

- **Master IP Address**

Enter the IP address of the master base station set on its **LAN | IP** tab.

- Click **OK**.

- Select the **Air Sync** tab.

Configuration	System	Suppl. Serv.	Master	Trunks	Radio	Radio config	PARI	SARI	Air Sync	Logout
General										
LAN										
IP										
LDAP										
DECT										
VoIP										
Unite										
Services										

Sync Mode

Sync RFPI

Alternative sync RFPI

Sync Region

- Set the **Sync Mode** to **Slave**.
- Click **OK**.

Registering the Slave Base Station

About this task

The slave base station needs to register and be synchronized with the master base station. Use the master base station configuration to register the slave base station.

* Note:

The following instructions assume you are installing an IPBS2, which has one LED lamp. The IPBS1 has two LED lamps. For more information on the base station LEDs and what their statuses indicate, see [Base Station Status Lamps](#) on page 14.

Procedure

1. Login to the master base station.
2. Select **Device Overview** and then select the **Radios** tab.

Configuration	Radios	Logout
General		
LAN		
IP		
LDAP		
DECT		
VoIP		
Unite		
Services		

Static Registrations

Name ↑	RFPI	IP Address	Sync	Region	Device Name	Version	Connected Time
IPBS2-12-86-81	9014AC1008	192.168.0.227	Master OK	0	IPBS2 [-/2017-10-26T08:36:56]	[10.0.5/10.0.5/IPBS2-C4/1A]	0d 0h 14m 29s

Radios: 1, Registrations: 1

Uninitialized Registrations

Name ↑	IP Address	Device Name	Version	Connected Time
IPBS-01-6f-9c	192.168.0.226	IP-DECT Base Station	[10.0.5/10.0.5/IPBS1-Y4/PD]	0d 0h 0m 26s Add

The new slave base station is shown as an unregistered device.

3. Click on **Add**.
4. On the popup menu that appears, click **OK**.

The slave base station will be listed as a registered device.

Configuration		Radios							Logout
General	Static Registrations								
LAN									
IP	Name	RFPI	IP Address	Sync	Region	Device Name	Version	Connected Time	
LDAP	IPBS2-12-86-81	9014AC1008	192.168.0.227	Master OK	0	IPBS2 [-/2017-10-26T08:36:56]	[10.0.5/10.0.5/IPBS2-C4/1A]	0d 0h 14m 29s	
DECT	IPBS-01-6f-9c	192.168.0.226	192.168.0.226	Slave OK	0	IP-DECT Base Station	[10.0.5/10.0.5/IPBS1-Y4/PD]	0d 0h 2m 25s	
VoIP	Radios: 2, Registrations: 2								

*** Note:**

It may take up to two minutes for the slave base station to synchronize with the master base station. During this time the LED will fast flash blue and the status shows as **Not in sync**. Once it is in sync, the LED changes to blue with a yellow flash and the status changes to **OK**.

Base Station Mounting

The base station can now be powered down and mounted in its intended operating position. The removable bracket on the back of the base stations can be used for either wall mounting using two screws suitable for the surface or for mounting on columns using two metal bands.

Mounting a Base Station using a Wallmount

About this task

Remove the mounting bracket from the base station. Use it as a template for marking the screw fixing holes. Note the diagram below indicating the required clearance for attaching the base station onto the mounting bracket.

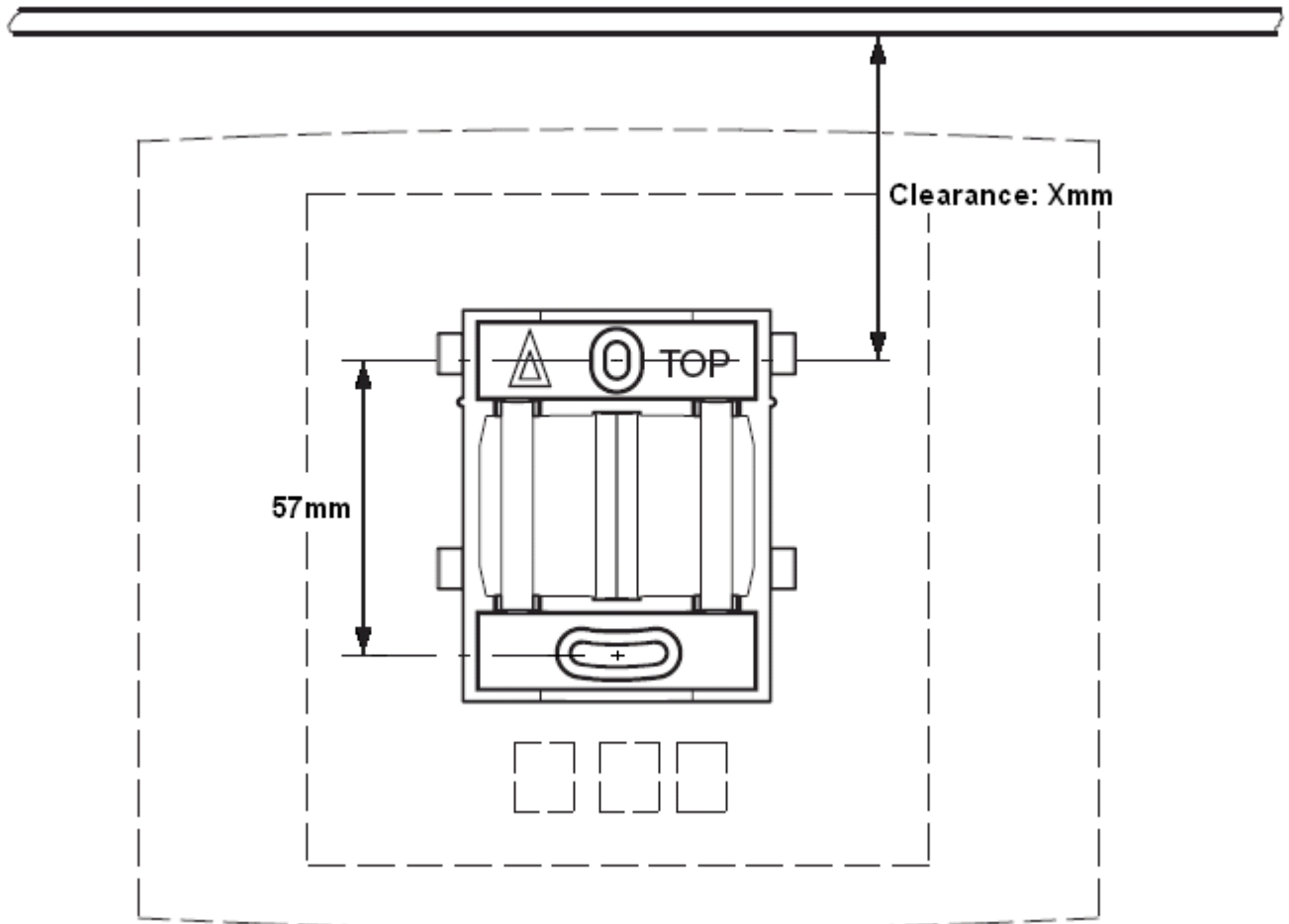

Procedure

1. Hold the mounting bracket with its flat side against the wall with the text 'TOP' upwards and mark the two holes. Observe the minimum distance between the top screw hole and the ceiling. This depends on the base station type as follows:

Base Station Type	Internal Aerials	External Aerials
IPBS1 or Digital Base Station	65mm	160mm
IPBS2	100mm	195mm

2. Drill the two holes using a 6mm diameter drill and insert the included wall plugs.
3. Position the mounting bracket with its flat side to the wall and fasten it with the two included 3.5mm diameter screws.

Mounting a Base Station on a Column/Pillar

The mounting bracket can be fixed to a pole of 45mm diameter or greater, or a beam of 50mm width minimum by using a strap or flexible metal band less than 30 mm wide. A suitable strap or flexible metal band is not included with the base station.

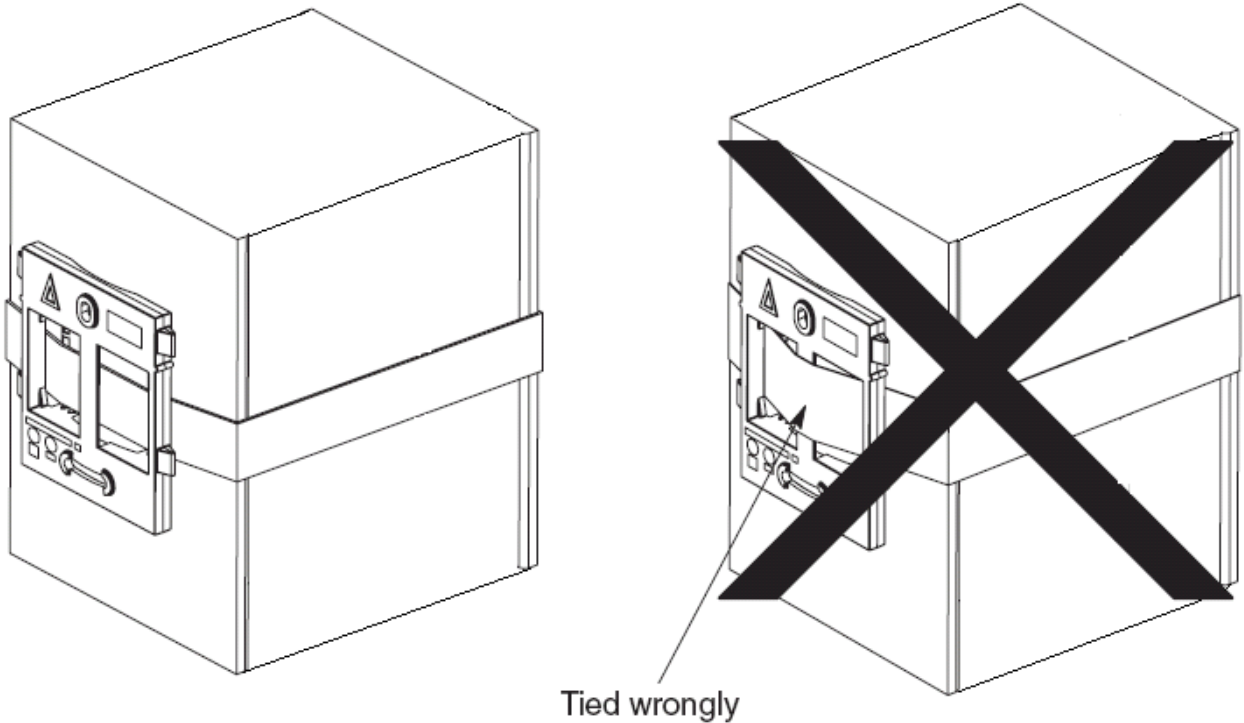

Note: Mounting a wireless base station directly on a steel beam or pillar could result in signal disruptions, such as dead zones or reflections. If it is absolutely necessary to mount the base station on a metallic surface, use spacers to separate the base station from the surface by 20-25 cm.

Subscribing Phones

Once the master base station has been configured and is connected to the IP Office, you can begin phone subscription.

There are two methods of phone subscription; **pre-configured** or **auto-create**.

- The **pre-configured** method requires the DECT users to be pre-configured in the master base station configuration.
- The **auto-create** method does not require users to be pre-configured if the auto-create users checkbox is enabled in the IP-DECT Line, Gateway tab.

In both cases, the IP Office configuration should also contain available Avaya IP Endpoint Licenses. The PARK code and Authentication Code of the DECT R4 system are required during subscription. The values set on the IP DECT line in the IP Office configuration are used.

 **Note:**

This method makes changes to the IP Office system configuration. Ensure that no copies of the configuration are open in Manager during subscription as sending that configuration back to the IP Office system will remove the subscriptions and require the handsets to be resubscribed.

Preconfigured Phone Subscription

About this task

This method is used when the IP Office IP DECT line's **Subscriptions** setting is set to **Preconfigured**. The SARI and Authentication Code set in the IP Office configuration are used. Using this method, entries for the IP DECT extensions and users must first be created in the IP Office configuration. The matching phones can then be subscribed.

Procedure

1. Set the IP DECT line's **Subscriptions** mode to **Preconfigured**.
2. Create an IP DECT extension and user entry for each phone.
3. Subscribe the phones.
4. Disable subscription when all phones have been subscribed.

Auto-Create Phone Subscription

About this task

This method is used when the IP Office IP DECT line's **Subscriptions** setting is set to **Auto-Create**. After successfully subscribing, the phone is assigned a temporary extension number which is the highest existing extension number plus 1.

You can accept this number or assign the desired extension number.

Procedure

1. Set the IP DECT line's **Subscriptions** mode to **Auto-Create**. Ensure that the **Auto-Create User** and **Auto-Create Extension** options are also selected.
2. Subscribe the phone to a temporary extension number.
3. Accept the temporary extension number (*#) or enter an alternate extension number (XXX*LLL#).
XXX is the extension number to use and LLL is the Login Code to assign to the user.
4. Disable subscription when all phones have been subscribed.

Allowing Subscription

Before phones are subscribed, subscription needs to be allowed by both the IP Office and the DECT R4 system.

Enabling IP Office Subscription

Procedure

1. Start IP Office Manager and receive the configuration from the IP Office system.
2. In the left-hand navigation pane, click on **Line** icon.
3. Select the **IP DECT Line**.
4. Select the **Gateway** tab.

The screenshot shows the configuration interface for a Line in the Gateway tab. The interface includes several sections:

- Line** (selected), **Gateway**, **VoIP**
- Auto-Create Extension**
- Auto-Create User**
- Enable DHCP Support**
- Boot File**: ADMM_RFP_1_1_13.tftp
- ADMM MAC Address**: 00 00 00 00 00 00
- VLAN ID**: [Empty field]
- Base Station Address List**: [Empty list area] with **Add...**, **Remove**, and **Edit...** buttons.
- Enable Provisioning**
- SARI/PARK**: 3110024377703
- Subscriptions**: Preconfigured (dropdown)
- Authentication Code**: [Masked with dots]
- Enable Resiliency**
- Status Enquiry Period**: 30 (dropdown)
- Prioritize Primary**
- Supervision Timeout**: 120 (dropdown)

5. Check that the **Auto-Create Extension** and **Auto-Create User** options are selected.
6. Click **OK**.
7. Send the configuration back to the IP Office.

Master Base Station Procedure

1. Access the master base stations configuration.
2. In the left-hand panel select **DECT**. Select the **System** tab.

Configuration	System	Suppl. Serv.	Master	Trunks	Radio	Radio config	PARI	SARI	Air Sync	Logout
General										
LAN										
IP										
LDAP										
DECT										
VoIP										
Unite										
Services										
Administration										
Users										
Device Overview										
DECT Sync										
Traffic										
Backup										
Update										
	System Name	DECT								
	Password	••••••••								
	Confirm Password	••••••••								
	Subscriptions	With System AC								
	Authentication Code	1234								
	Default Language	English								
	Frequency	Europe								
	Enabled Carriers	0 1 2 3 4 5 6 7 8 9								
		<input checked="" type="checkbox"/> <input checked="" type="checkbox"/> <input checked="" type="checkbox"/> <input checked="" type="checkbox"/> <input checked="" type="checkbox"/> <input checked="" type="checkbox"/> <input checked="" type="checkbox"/> <input checked="" type="checkbox"/> <input checked="" type="checkbox"/> <input checked="" type="checkbox"/>								
	Coder	G729A Frame (ms) 60 Exclusive <input type="checkbox"/> SC <input type="checkbox"/>								
	<input type="button" value="OK"/> <input type="button" value="Cancel"/>									

3. Check that the **Subscriptions** field:

- **With System AC**

IP Office provisioning will automatically set this field when the IP DECT line subscription setting is set to **auto-create**.

- **With User AC**

IP Office provisioning will automatically set this field when the IP DECT line subscription setting is set to **Preconfigured**.



- Note the number set in the **Authentication Code** field.
- Click **OK**.

Manually Creating Extensions

About this task

If the IP DECT line subscription setting is set to **Preconfigured**, you must manually add extension and user entries for each handset to the IP Office configuration.

Procedure

1. Click on  **Extension**.
2. Click on the  icon and select **IP DECT Extension**. This option is greyed out until an IP DECT line is added to the configuration.
3. Select the **Extn** tab. Set the **Base Extension** number to a currently unused extension number.

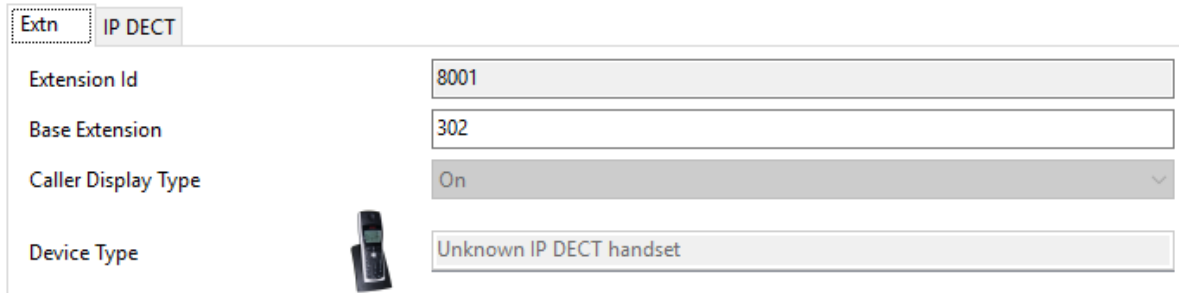

Extn	IP DECT
Extension Id	8001
Base Extension	302
Caller Display Type	On
Device Type	Unknown IP DECT handset

4. Select the **IP DECT** tab.

The appearance of this tab varies depending on whether the IP DECT line has **Enable Provisioning** selected or not. The following example shows this tab when provisioning is enabled.

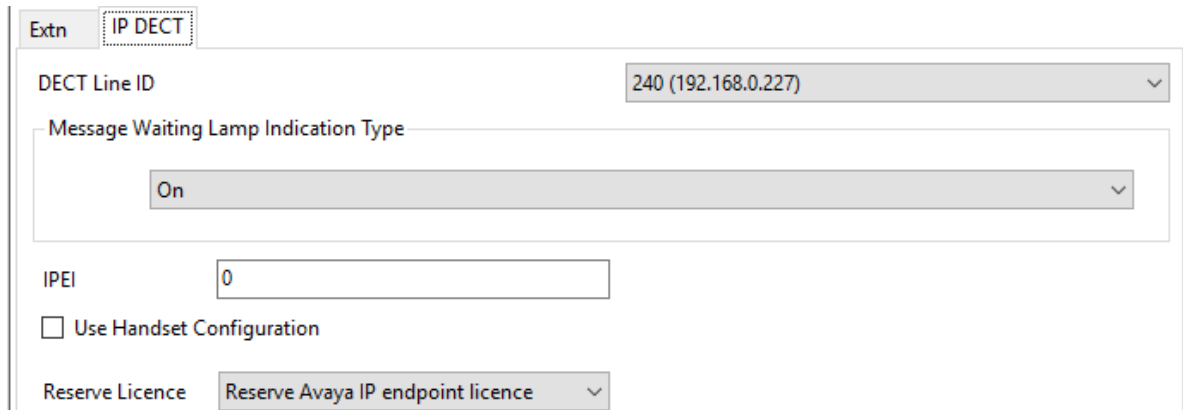

Extn	IP DECT
DECT Line ID	240 (192.168.0.227)
Message Waiting Lamp Indication Type	On
IPEI	0
Use Handset Configuration	<input type="checkbox"/>
Reserve Licence	Reserve Avaya IP endpoint licence

- a. Set the **Message Waiting Lamp Indication Type** to **On**.
- b. Select the Reserved Avaya IP endpoint license option. This option will be greyed out if there are insufficient licenses. If this option is selected, the phone will be licensed before any other Avaya IP endpoints for which this option has not been set.
- c. Set the IPEI to match that of the handset. For new phones the IPEI is shown on the screen. For other phones it can be displayed by selecting **Menu | Settings | Device Info | IPEI/IPDI**. It is also shown on a label under the battery.
 - For 3700 Series phones, the IPEI can be displayed by selecting **Menu | Settings | Device Info | IPEI/IPDI**. It is also printed on a label under the phone's battery.

- If **Use Handset Configuration** is selected, the handset user is able to set the phone language and date/time format. If not selected, those settings will be driven by the system or user locale settings in the IP Office configuration.
- Click **OK**.
- IP Office Manager will prompt whether you want to create an associated user. Select **Yes**.
- The user settings are displayed. Adjust any of these if required and click **OK**.
- Repeat the process to create any other extension and user entries required. Then save the configuration back to the IP Office system.

Subscribing a Phone

The method of subscription is largely the same regardless of whether the IP Office's IP DECT line **Subscriptions** setting is set to **Auto-Create** or **Preconfigured**.

You will need the system SARI code and Authentication Code set in the IP DECT line configuration during the subscription process. You also need to enable subscription, which is only valid for 2 minutes, in the master base station.

3700 Series Phones

About this task

Using the Telephone user interface, perform the following procedure to subscribe the handsets.

- Switch on the phone:
 - **3720**: Select **Menu | Settings | System | Subscribe**.
 - **Others**: Select **Menu | Connections | System | Subscribe**.

Display	Actions
Display	Actions
	<p>Details of the phone's current subscription are displayed. Select Next.</p>

Table continues...



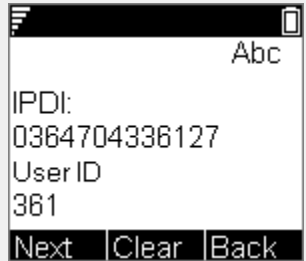

Display	Actions
	<p>The System name is just used by the phone to identify the different subscriptions it may have.</p> <p>Enter any name and select Next.</p>
	<p>The phone will display a list of telephone system types to which it can connect. Scroll the selected option to IP-DECT and select Next.</p>
	<p>The phone now requires the PARK (SARI) and AC (authentication code) of the system to which it should subscribe.</p> <p>Enter the PARK and then scroll to the AC field.</p> <p>Enter the System AC and select Next.</p>
	<p>The Protection on? prompt is displayed.</p> <ul style="list-style-type: none"> • If you select No, the user can delete the subscription from the list of subscriptions known by the phone. • If you select Yes, the user cannot delete the subscription.
	<p>A summary of the subscription details is shown. Check that the values are correct</p>

Table continues...

Display	Actions
	<p>Select OK.</p> <p>The phone broadcast for DECT systems to which it can subscribe.</p>
	<p>When a DECT system is located, the handset will attempt to subscribe to that system.</p>
	<p>The success or failure of the subscription is indicated.</p>

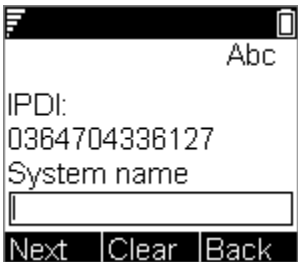
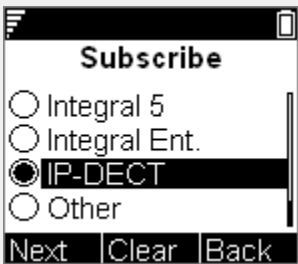
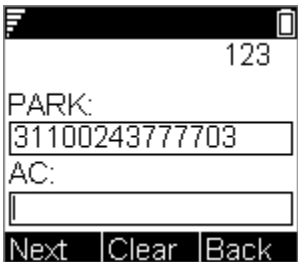
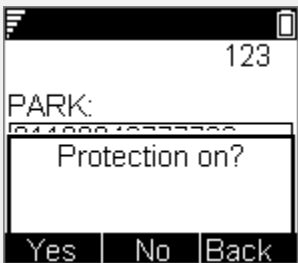
The display shown after successful subscription will depend on whether anonymous subscription is being used or the phone matches an existing extension in the IP Office configuration.

Auto-Create Subscription Mode

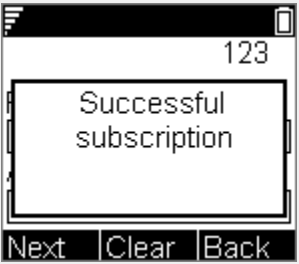
About this task

	<p>If the phone displays Enter New Login, it has been assigned a temporary extension number, shown in brackets. The temporary number is simply the highest existing extension number plus 1.</p> <ul style="list-style-type: none"> To accept the temporary extension number as permanent, dial *# and make the call. To specify a different extension number, dial XXX*LLL# where XXX is the extension number to use and LLL is the Login Code to assign to the user. To accept the temporary extension as permanent but set a login code for the user, dial *LLL# where LLL is the Login Code to assign to the user.
---	--

Preconfigured Subscription Mode

About this task



If the IPEI of the phone matches an existing extension entry in the IP Office configuration, the phone will use the existing settings.

This may occur even when using Auto-Create subscription mode if the phone is an existing extension re-subscribing to the system.

3701/3711 Phones

About this task

This method is only supported if the IP DECT line's **Subscriptions** setting is set to **Preconfigured** and matching configuration entries for the extensions have been created.

Procedure

1. Switch on the phone.
2. Select **Menu | System | Subscription | Subscribe HS**.
3. Select **PABX-PIN**.
4. Enter the authentication code.

Upgrading Phones

About this task

It may be necessary to upgrade to software used by the 3700 Series phones. For new installations it is assumed that the Windows Device Manager and advanced chargers will be used for this.

Installing Windows Device Manager to Upgrade Phones

About this task

Procedure

1. Browse to the location where you unpacked the IP Office software for DECT R4. Locate the *Avaya WinPDM* folder.
2. Double-click on **Setup.exe**.

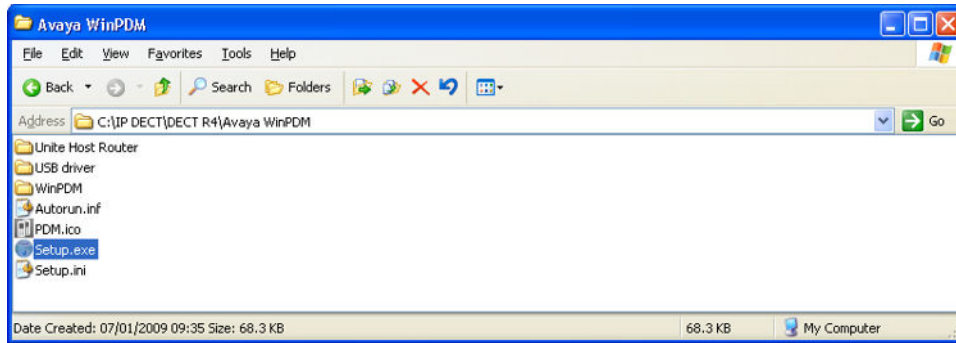

3. Click **Next**.

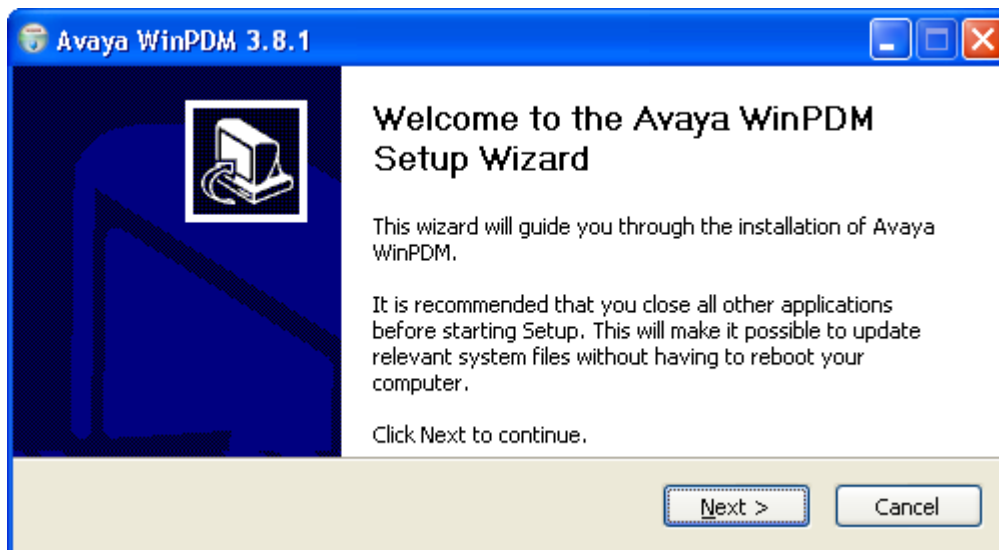

4. Select **Avaya WinPDM** and click **Next**.

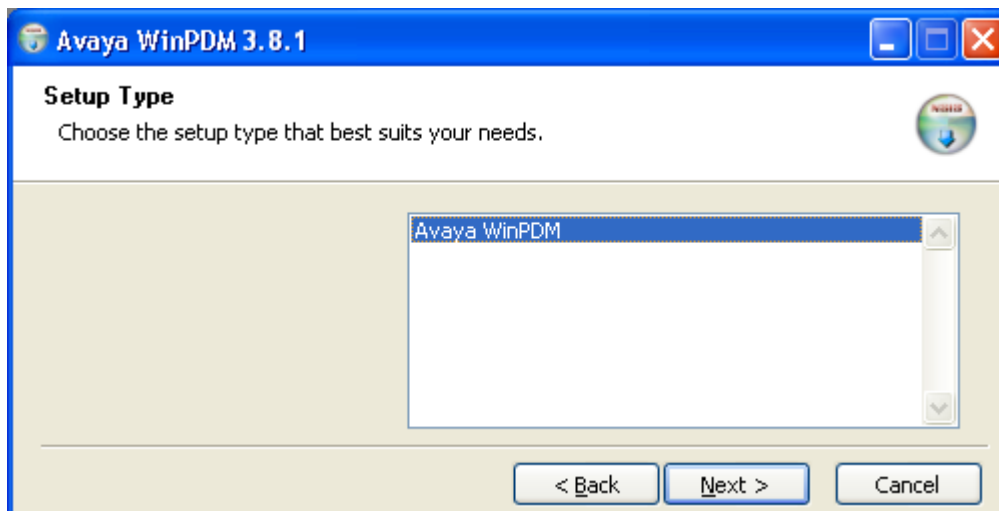

5. Click **Install**.

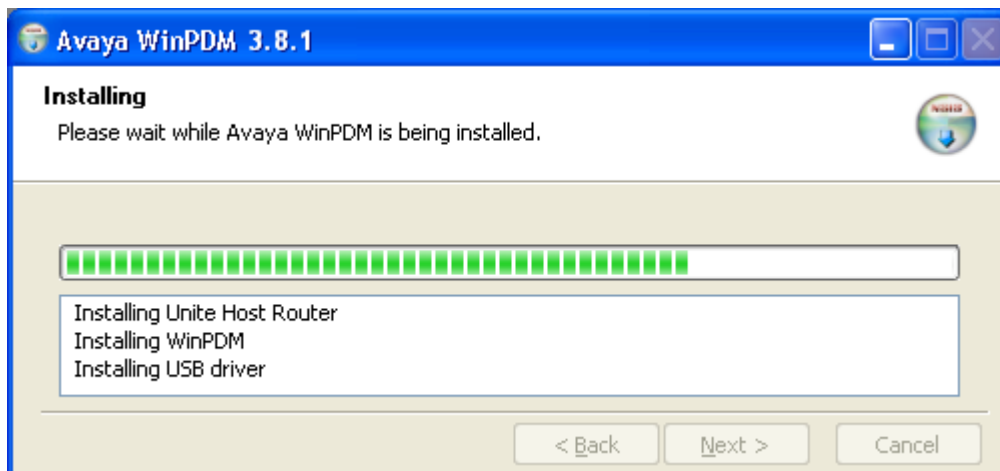
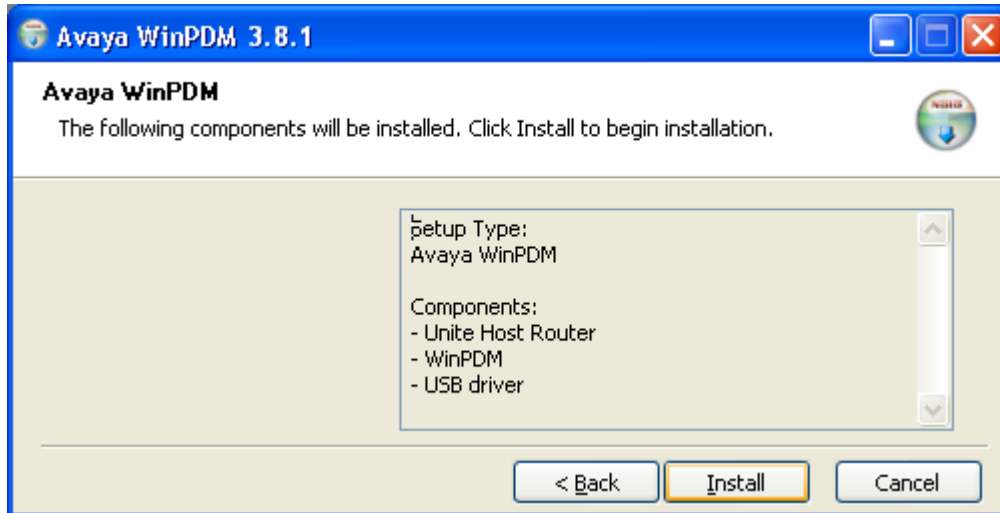

6. When the installation is complete, click on **Finish**.

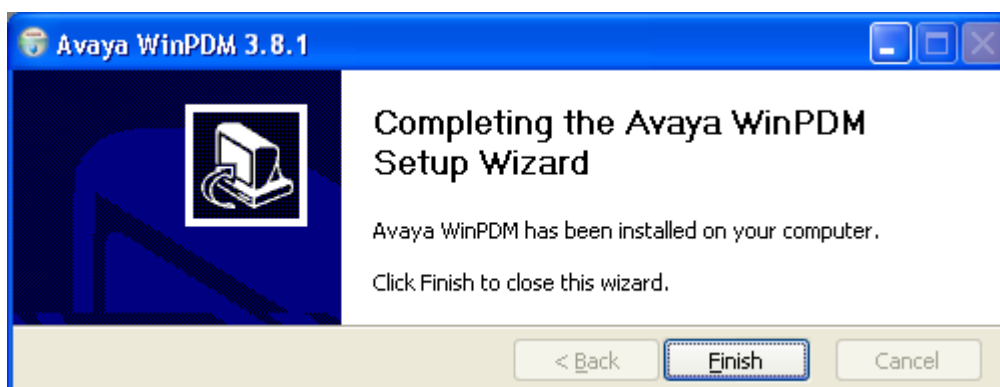

Starting Windows Device Manager Procedure

1. Select **Start | All Programs | Avaya WinPDM**.

2. Click on the **Avaya WinPDM** icon.

- If this is the first time that Avaya WinPDM has been run, you will be asked to create a site. Enter a name for the site that you have been installing and click **OK**.
- If this is the first time that Avaya WinPDM has been run, you will be prompted to import parameter definition files.

Upgrading Phone Software

About this task

DECT R4 is supported on a range of Avaya systems. However, for IP Office operation, only software specifically documented as having been tested and supported with IP Office should be used. Details of supported software for any particular IP Office release is included in the IP Office Technical Bulletin for that release.

Procedure

1. Within the Avaya Device Manager, select the **Devices** tab.

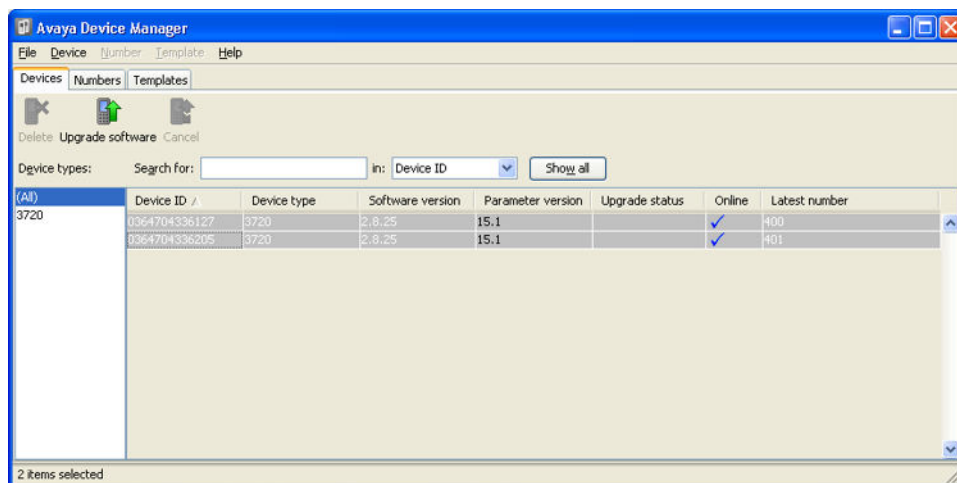

2. The current software version of each phone is shown. Compare this to the software versions available, shown by the version set as part of the .pkg file name included with the DECT R4 software.

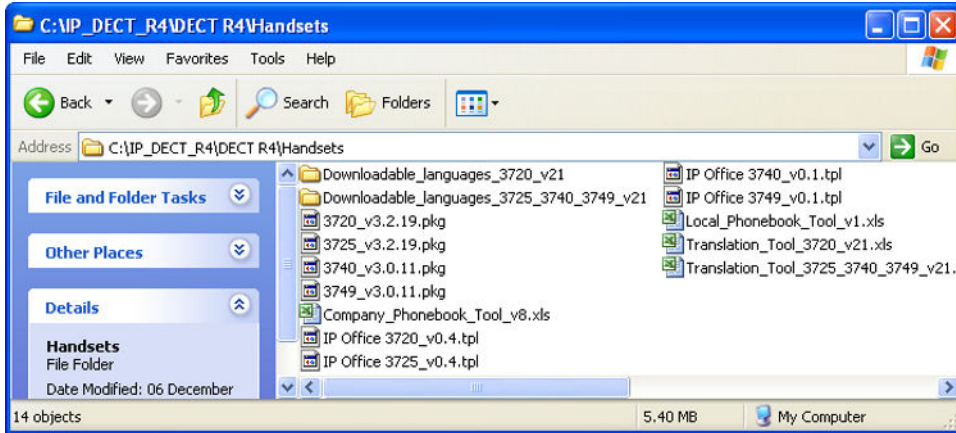

3. In the device manager, select the phones that you want to upgrade.
4. Click **Upgrade Software**. The menu shown will depend on whether you are using the AIWS for an over the air upgrade or WinPDM for an in charger upgrade.

• **AIWS Upgrade Software Menu**

This menu is shown when using the AIWS based device manager to upgrade phones over the air. This method supports a number of additional options but is much slower than upgrading phones in an advanced charger.

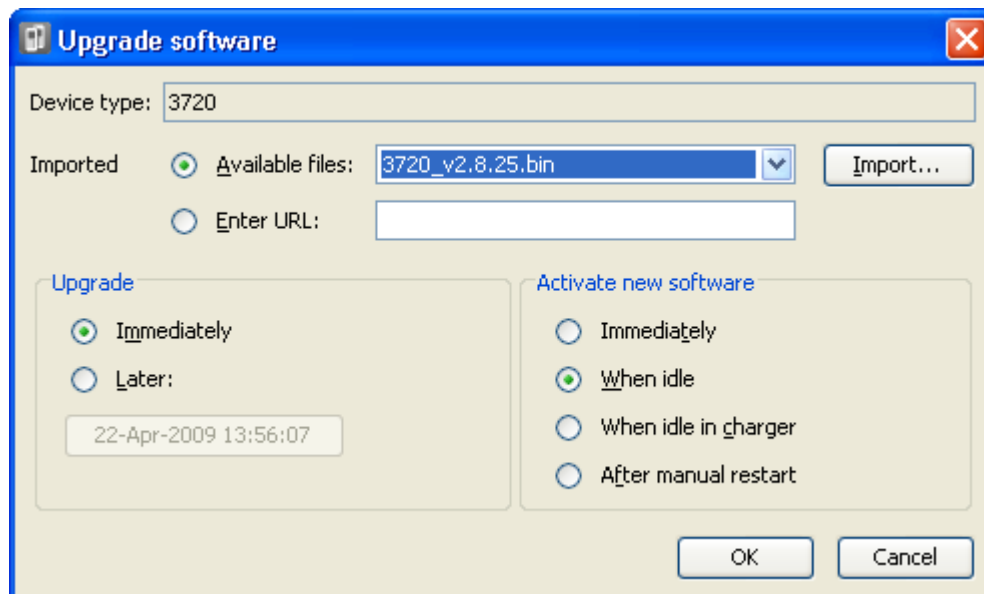

• **Advanced Charger/WinPDM Upgrade Menu**

This menu is shown when using the Windows based device manager to upgrade a phone currently in an advanced charger connected to the PC by USB or LAN. See [Installing Windows Device Manager](#) on page 90.

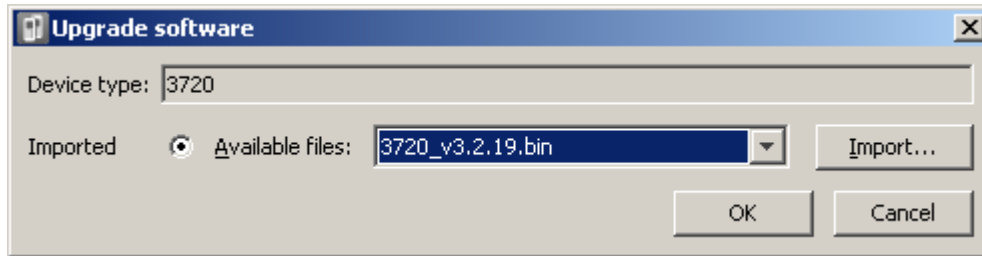

- If you have already imported the parameter definition files for the phones, use the **Available Files** drop-down to select the software bin file for the type of phone being upgraded. Otherwise click on **Import** and browse to the .pkg files for the phone type.
- Select the other upgrade settings required and click **OK**.

The upgrade begins. The following images show a typical upgrade as it is being performed on a 3720 device.

(All)	Device ID /	Device type	Software version	Parameter version	Upgrade status	Online	Latest number
3720	0364704336127	3720	2.8.25	15.1	Downloading	✓	400
	0364704336205	3720	2.8.25	15.1	Downloading	✓	401

(All)	Device ID /	Device type	Software version	Parameter version	Upgrade status	Online	Latest number
3720	0364704336127	3720	2.8.25	15.1	12%	✓	400
	0364704336205	3720	2.8.25	15.1	12%	✓	401

(All)	Device ID /	Device type	Software version	Parameter version	Upgrade status	Online	Latest number
3720	0364704336127	3720	2.8.25	15.1	Complete	✓	400
	0364704336205	3720	2.8.25	15.1	Complete	✓	401

Displaying Subscribed Users

There are a number of ways to display the phones subscribed to the system.

Using the Master Base Station

Procedure

1. Login to the master base station.
2. Select Users and select the Users tab.
3. Click on **show**.

Details of the subscribed phones are shown.

Configuration	Users	Anonymous	Logout														
General	PARK 31100243777703 PARK 3rd pty 2110024755 Master Id 0 <input type="text"/> show		User Administrators Long Name Name User Administrators: 0														
LAN			Users <table border="1"> <thead> <tr> <th>No</th> <th>Display</th> <th>IPEI / IPDI</th> <th>AC</th> <th>Prod</th> <th>SW</th> <th>Registration</th> </tr> </thead> <tbody> <tr> <td>660</td> <td>Extrn660 660</td> <td>036470433620</td> <td>1234</td> <td>3720</td> <td>3.2.19</td> <td>Subscribed</td> </tr> </tbody> </table> Users: 1	No	Display	IPEI / IPDI	AC	Prod	SW	Registration	660	Extrn660 660	036470433620	1234	3720	3.2.19	Subscribed
No	Display	IPEI / IPDI	AC	Prod	SW	Registration											
660	Extrn660 660	036470433620	1234	3720	3.2.19	Subscribed											
DECT																	
Services																	
Administration																	
Users																	
Device Overview																	
Backup																	

Using IP Office System Status

The System Status application lists DECT extensions as a subset of H.323 extensions. It can also be used to force the unsubscription of a phone.

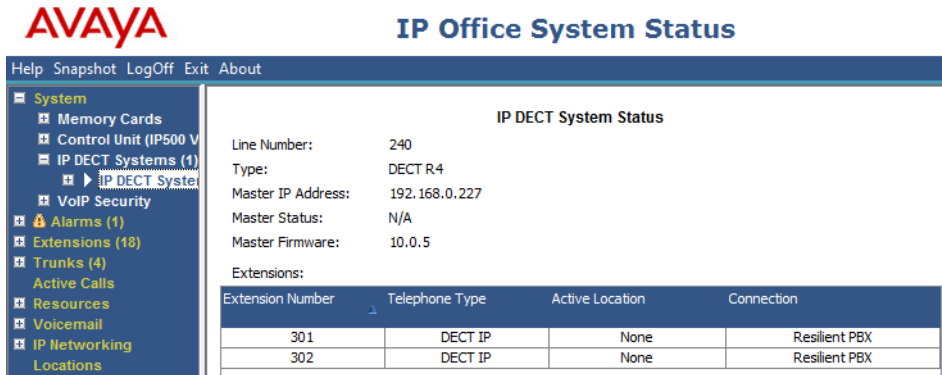

Unsubscribing Phones

DECT phones can subscribe to multiple DECT systems and can then be switched between the systems to which they are currently subscribed.

The Unsubscribe option provided through phone menus does not unsubscribe a phone from the DECT R4 system or IP Office. This option removes details of the subscribed system from the phone. The Unsubscribe function only works for subscriptions where the Protection option was set to **No** during the original subscription.

Resubscribing the phone reinstates the DECT R4 system in the list of systems to which the phone can be subscribed.

To remove a phone from a system that is using IP Office provisioning, the phone's extension entry should be deleted from the IP Office configuration. To remove a phone from a system that is not using IP Office provisioning, the phone's extension entry must be deleted from both the IP Office configuration and the master base station configuration.

Disabling Subscription

About this task

When all DECT phones have been subscribed, Avaya recommends that you disable any further subscriptions. This does not affect re-subscription by extensions that are already configured in the IP Office configuration.

Ensure that no copies of the configuration are open in Manager during subscription, as sending such a copy of the configuration back to the IP Office system will replace the subscriptions and require the handsets to be subscribed again. Following any handset subscription, a new copy of the configuration should always be loaded in IP Office Manager if any other configuration changes are required.

Procedure

1. In IP Office Manager, click on **Line**.
The list of existing lines is shown.
2. Select the **IP DECT Line** previously created.
3. Click on the **Gateway** tab.
4. Change the **Subscriptions** setting to **Disabled**.
5. Click **OK** to save the configuration back to the IP Office system.

Chapter 4: DECT Resilience

From Release 9.1, IP Office Release supports two methods for ensuring continued DECT availability. Both methods can be combined to ensure maximum availability. In both case, it is recommended that normal installation of the system is completed and tested before then adding mirroring and or switch resilience.

- **Master Base Station Mirroring:** It is now possible to configure two base stations to act as 'mirrored' master base stations. One becomes the active master base station whilst the other becomes a standby master base station. If for any reason the active master base station becomes unavailable, the IP Office switches to using the standby master base station to continue DECT operation. Mirroring is not supported between compact and non-compact base stations. However, it is supported between a DECT gateway and non-compact base station.
- **IP Office Switch Resilience:** The IP Office controlling the DECT system can be configured to allow that control to be automatically passed to another IP Office system when it is not available. The SCN line between the two systems can be configured to allow DECT backup for resiliency scenarios in the same was as existing resilience for H.323 IP telephones. If for any reason the primary IP Office system becomes unavailable, DECT control and users are switched to the backup IP Office system.

Related links

[Configuring Base Station Mirroring](#) on page 98

[Configuring Switch Resilience](#) on page 100

[Viewing and Controlling Resilience](#) on page 104

Configuring Base Station Mirroring

To increase resilience of the DECT network, two base stations can be configured to operated as 'mirrored' master base stations. Only one is the active master base station at any time, however the other takes over as the master base station when required.

All the normal requirements for the master base station apply to both the mirrored base stations. That includes the air sync requirements unless air sync is assigned to another base station. See [Configuring Air Sync](#).

Mirroring is not supported between compact and non-compact base stations. However, it is supported between a DECT Gateway and non-compact base station.

Related links

- [DECT Resilience](#) on page 98
- [Configuring the IP Office](#) on page 99
- [Configuring the Mirrored Base Stations](#) on page 99
- [Activating the Master Base Station](#) on page 100

Configuring the IP Office

In the IP Office system, the IP DECT line needs to be configured with the IP addresses of both of the mirrored base stations.

Procedure

1. Using Manager, retrieve the configuration from the system.
2. Click on **Line**. The list of existing lines is shown.
3. Select the IP DECT line and then select the **VoIP** tab.
4. In the **Gateway IP Address** and the **Standby IP Address** fields, enter the IP addresses of the two base stations that will be mirrored.
5. Save the changes.

Related links

- [Configuring Base Station Mirroring](#) on page 98

Configuring the Mirrored Base Stations

Use the following process to the configure the master base station and its mirror.

Before you begin

This process requires access to tabs and fields currently only visible when **Show Advanced Options** is selected.

Procedure

1. Login to the first master base station.
2. Select **DECT** and then select the Master tab.
3. Set the **Mode** to `Mirror`.
4. Set the **Mirror Master IP address** field to the IP address of the other base station.
5. Select the **DECT | Radio** tab.
6. In the **Master IP Address** field, enter the base station's own IP address.
7. In the **Alt. Master IP Address** field, enter the IP address of the other master base station. Click **OK**.

8. Reset the base station.
9. Repeat this process for the other mirrored base station.

Next steps

You can now activate the master base station.

Related links

[Configuring Base Station Mirroring](#) on page 98

Activating the Master Base Station

Only one base station in the mirrored pair acts as the master base station at any time. The initial selection is done through the base station menus of the selected member of the mirrored pair.

Before you begin

This process requires access to tabs and fields currently only visible when **Show Advanced Options** is selected.

Procedure

1. Login to one of the mirrored master base stations.
2. Select **DECT** and then select the **Master** tab.
3. Click **Activate mirror**. That base station is made the currently active master base station in the mirrored pair.

Related links

[Configuring Base Station Mirroring](#) on page 98

Configuring Switch Resilience

For IP Office systems in a multi-site network such as a Small Community Network or Server Edition network, control of the IP Office's DECT system can be transferred to another IP Office system. This failover occurs when the master base station cannot detect its primary IP Office system, that is the IP Office system configured with an IP DECT line to it.

During failover, the specified failover IP Office system takes control and hosts the DECT extensions and users that were previously on the primary IP Office system. However, no changes to the DECT configuration or additional handset subscriptions are allowed.

The failover IP Office system can still host its own DECT R4 system using its own IP DECT line and master base station. When that is the case, it can only support failover from another system up to its maximum capacity of DECT users including its existing native DECT users.

For a provisioned installation:

- The centralized phone book is still supported after failover. However, this does not apply if the phone book is being provided by an AIWS.
- An **R** is displayed on the 3700 Series DECT phones when they are in failover.
- By default DECT control and extensions automatically return to the primary IP Office system when it is available again.

For a non-provisioned installation:

- The centralized phonebook is not supported during failover.
- The handsets do not display any indication that their system is in failover.

Related links

[DECT Resilience](#) on page 98

[Provisioned Base Station Configuration](#) on page 101

[Non-Provisioned Base Station Configuration](#) on page 102

[IP Office Configuration for Switch Resilience](#) on page 103

[IP Office Line Configuration for DECT Resilience](#) on page 103

Provisioned Base Station Configuration

For a provisioned installation, the master base station needs to be configured to accept a provisioning connection from the backup IP Office system.

Before you begin

This process requires access to tabs and fields currently only visible when **Show Advanced Options** is selected.

Procedure

1. Login to the master base station.
2. Select **Services** and then select the **Provisioning** tab.
3. Set the **Current View** to **Redundant**.
4. Select the **Enable** option.
5. The IP Office security settings control whether HTTPS is supported between the master base station (by default it is supported) and the backup IP Office system.
6. Set the **PBX IP Address** to match the backup IP Office system.
7. In the **User Name** and **Password** fields, set the details that match the fallback IP Office system's service user configured for IP DECT.
8. Ensure that the **Base directory** is set to **/system/backupipdect/** instead of **/system/ipdect/**.
9. Click **OK**.

10. Reset the base station.

Next steps

You must now also configure the IP Office system for switch resilience.

Related links

[Configuring Switch Resilience](#) on page 100

Non-Provisioned Base Station Configuration

For non-provisioned systems, the master base station needs to be configured with details of a redundant trunk connection to the fallback IP Office and when to use that trunk.

Before you begin

This process requires access to tabs and fields currently only visible when **Show Advanced Options** is selected.

Procedure

1. Login to the master base station.
2. Select **DECT** and then select the **Master** tab.
3. Enable the **PBX Resiliency** and click **OK**.
4. Select the **Trunks** tab. Options for configuring the redundant trunk to the backup IP Office system are now displayed.
5. In the **Trunk Settings** section, configure how fallback should operate:
 - **Prioritize primary trunk:** If selected, when during fallback the master base station detects that the primary IP Office has returned to normal operation, it returns DECT control to it. If not selected, the fallback IP Office retains control until it is manually returned using SSA.
 - **Status Inquiry Period:** This field set how frequently (in seconds) the master base station should check the status of the primary IP Office. This value and the Status Enquiry Period set in the IP Office system configuration should match.
 - **Supervision Timeout:** This field sets how long after contact is lost (in seconds) before the master base station should fallback to the fallback IP Office system. This option is only supported a provisioned installation.
6. In the **Redundant Trunks** settings, set the port fields to **1720** and the **CS IP Address** to the IP address of the fallback IP Office system.
7. Click **OK**.
8. Reset the base station.

Next steps

You can now configure the IP Office system for switch resilience.

Related links

[Configuring Switch Resilience](#) on page 100

IP Office Configuration for Switch Resilience

For DECT switch resilience, the IP Office is configured as shown below. Only the primary IP Office needs this configuration. However, for provisioned systems, the security service user on the fallback IP Office must be enabled and configured to match the settings entered for the redundant provisioning connection.

Procedure

1. Receive the IP Office configuration.
2. Click on **Line**. The list of existing lines is displayed.
3. Select the **IP DECT Line**.
4. Select the **Gateway** tab.
5. In the **Enable Resiliency** section, select **Enable Resiliency**.
6. Only change the other values if necessary:
 - **Status Enquiry Period**: This field set how frequently (in seconds) the master base station should check the status of the primary IP Office. For a non-provisioned installation, this value should match the Status Inquiry Period set in the master base station.
 - **Prioritize Primary**: If selected, when during fallback the primary IP Office returns to normal operation, DECT control is automatically returned to it. If not selected, the fallback IP Office retains control until it is manually returned using the System Status application.
 - **Supervision Timeout**: This field sets how long after contact is lost (in seconds) before the master base station should fallback to the fallback IP Office system. This option is only accessible here for a provisioned installation. For a non-provisioned installation the value is set through the master base station.
7. Click OK.
8. Save the settings back to the system.

Related links

[Configuring Switch Resilience](#) on page 100

IP Office Line Configuration for DECT Resilience

The IP Office lines between the systems need to be configured to allow switch resilience.

Procedure

1. Select the IP Office line between the primary system and the backup system.
2. In the **SCN Backup Options**, select **Supports Fallback** and **Backs up my IP Dect Phones**.
3. Save the settings back to the system.

Related links

[Configuring Switch Resilience](#) on page 100

Viewing and Controlling Resilience

Using the IP Office System Status Application you can view the status of both an IP Office system and also any DECT systems to which it is connected. This is done by selecting **System | IP DECT Systems**.

Selecting the IP DECT System then displays details of the particular system and extensions being supported by that system. The addresses and status of the mirrored master base stations is indicated. For the extensions, the connect being used is also indicated.

The menu provides a number of controls:

- **Unsubscribe:** Force the selected extension to unsubscribe.
- **Switch to Backup Node:** Force the DECT connection to switch from the primary IP Office to the fallback IP Office.
- **Switch to Primary Node:** Force the DECT connection to switch from the fallback IP Office to the primary IP Office.

Related links

[DECT Resilience](#) on page 98

Chapter 5: IP DECT Gateway Installation

Before installation ensure that you have performed an assessment of the power consumption requirements of the digital base stations. This will determine whether the base stations can be powered directly by the IP DECT Gateway or each will need their own separate power adapters. If powered using separate power adapters, the EPP power wires from the IP DECT Gateway should not also be connected.

IP DECT Gateway Installation Summary

About this task

The configuration process for the IP DECT Gateway is very similar to that for an IP base station. In a new DECT R4 system installation, Avaya recommends that the IP DECT Gateway is installed as the master base station for the system. This does not affect the allowed number of IP and or digital base stations.

The installation of a IP DECT Gateway as a master base station can be done as part of either a provisioned installation or non-provisioned installation. If the IP DECT Gateway is being added to an existing system, it can be added in the same way as for a new slave base station.

A summary of the installation stages is as follows:

Procedure

1. Install in rack.
2. Attach power cable.
3. Connect the unit to the LAN using the LAN1 port.
4. Connect the digital base station cables.
5. Power on the unit.
6. Access and configure the unit in the same way as for a base station. The configuration required will depend on whether the IP DECT Gateway is being used as a master base station for the system.

Note:

If an IP DECT Gateway is being installed, Avaya recommends configuring the IP DECT Gateway as the master base station for the system. To configure the IP DECT gateway as a master base station, see [Master Base Station Setup](#) on page 55.

Digital Base Station Power Consumption

The IP DECT Gateway can be used to power digital base stations via the same cable connection as used for signalling. However, the maximum power provision of the IP DECT Gateway is 15W and the power consumption of each digital base station is dependent on the cable wire size and length. The table below indicates the power consumption and can be used to calculate if the IP DECT Gateway can directly power the digital base stations. In cases where the IP DECT Gateway cannot directly power all the digital base stations, some of the base stations will need a separate power connection.

Cable Length in Meters	0.4mm Wire Diameter		0.5mm Wire Diameter		0.6mm Wire Diameter	
	0 EPP	1 EPP	0 EPP	1 EPP	0 EPP	1 EPP
0	5.0	5.0	5.0	5.0	5.0	5.0
100	5.2	5.1	5.1	5.1	5.1	5.1
200	5.3	5.2	5.2	5.1	5.1	5.1
300	5.6	5.3	5.3	5.2	5.2	5.1
400	5.8	5.5	5.5	5.3	5.3	5.2
500	6.1	5.6	5.6	5.4	5.4	5.2
600	6.5	5.8	5.8	5.5	5.4	5.3
700	7.1	6.0	6.0	5.6	5.5	5.3
800	8.1	6.2	6.2	5.7	5.6	5.4
900	—	6.5	6.5	5.8	5.7	5.4
1000	—	6.9	6.9	5.9	5.8	5.5
1100	—	7.3	7.3	6.1	5.9	5.6
1200	—	8.1	8.1	6.2	6.1	5.6
1300	—	—	—	6.4	6.2	5.7
1400	—	—	—	6.6	6.4	5.8
1500	—	—	—	6.9	6.6	5.8

The following power supply adapters are available to power a base station locally. The maximum length of cable from the adapter to the base station must not exceed 10 meters.

- **For European countries:** Version 130137B.
- **For the United Kingdom:** Version 130136B.
- **For the United States and Canada:** Version 130138A.
- **For Australia:** Version 130139B.

Installing the Digital Base Stations

Apart from the physical connection and power requirements, no configuration is required. The appropriate firmware files are automatically provided to the base stations by the IP DECT Gateway.

Use the following cable pin-out to prepare the cable for connecting the digital base station to the IP DECT Gateway. Remember to allow sufficient cable length to allow for any potential repositioning of the base stations that may be required.

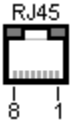
Base Station	Pin	MDI (Crossover)	Wire	Note
	1	Power	White/Orange	On connection if using the IP DECT Gateway for power. Do not connect if powering the digital base station using a separate power supply adapter. Refer to Digital Base Station Power Consumption on page 106.
	2	Power	Orange/White	
	3	Data 1a	White/Green	—
	4	Data 0a	Blue/White	—
	5	Data 0b	White/Blue	—
	6	Data 1b	Green/White	—
	7	Not used	White/Brown	—
	8	Not used	Brown/White	—

Mounting

About this task

The base station can now be powered down and mounted in its intended operating position. The removable bracket on the back of the base stations can be used for either wall mounting using two screws suitable for the surface or for mounting on columns using two metal bands.

Mounting a Base Station using a Wallmount

About this task

Remove the mounting bracket from the base station. Use it as a template for marking the screw fixing holes. Note the diagram below indicating the required clearance for attaching the base station onto the mounting bracket.

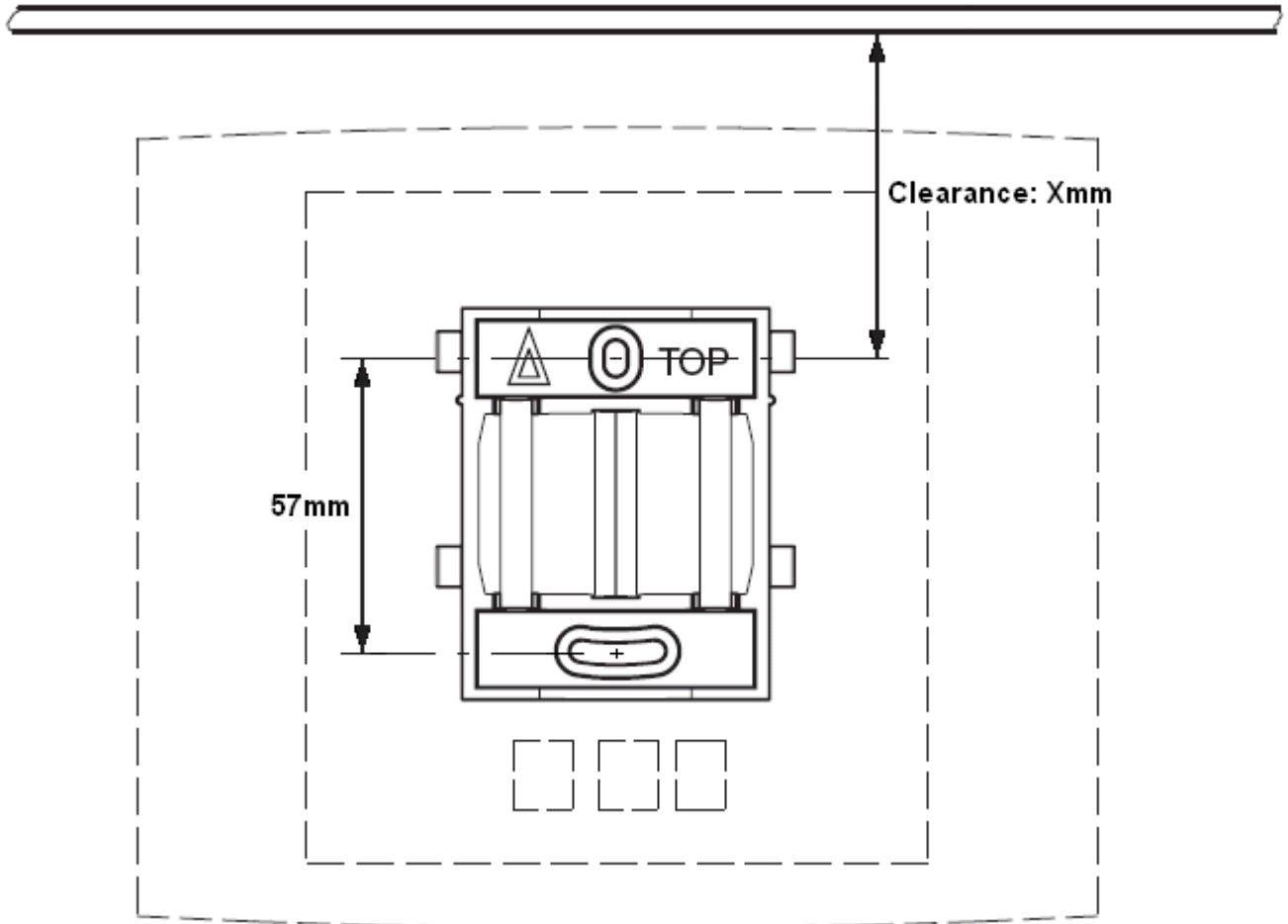

Procedure

1. Hold the mounting bracket with its flat side against the wall with the text 'TOP' upwards and mark the two holes. Observe the minimum distance between the top screw hole and the ceiling. This depends on the base station type as follows:

Base Station Type	Internal Aerials	External Aerials
IPBS1 or Digital Base Station	65mm	160mm
IPBS2	100mm	195mm

2. Drill the two holes using a 6mm diameter drill and insert the included wall plugs.
3. Position the mounting bracket with its flat side to the wall and fasten it with the two included 3.5mm diameter screws.

Mounting a Base Station on a Column/Pillar

The mounting bracket can be fixed to a pole of 45mm diameter or greater, or a beam of 50mm width minimum by using a strap or flexible metal band less than 30 mm wide. A suitable strap or flexible metal band is not included with the base station.

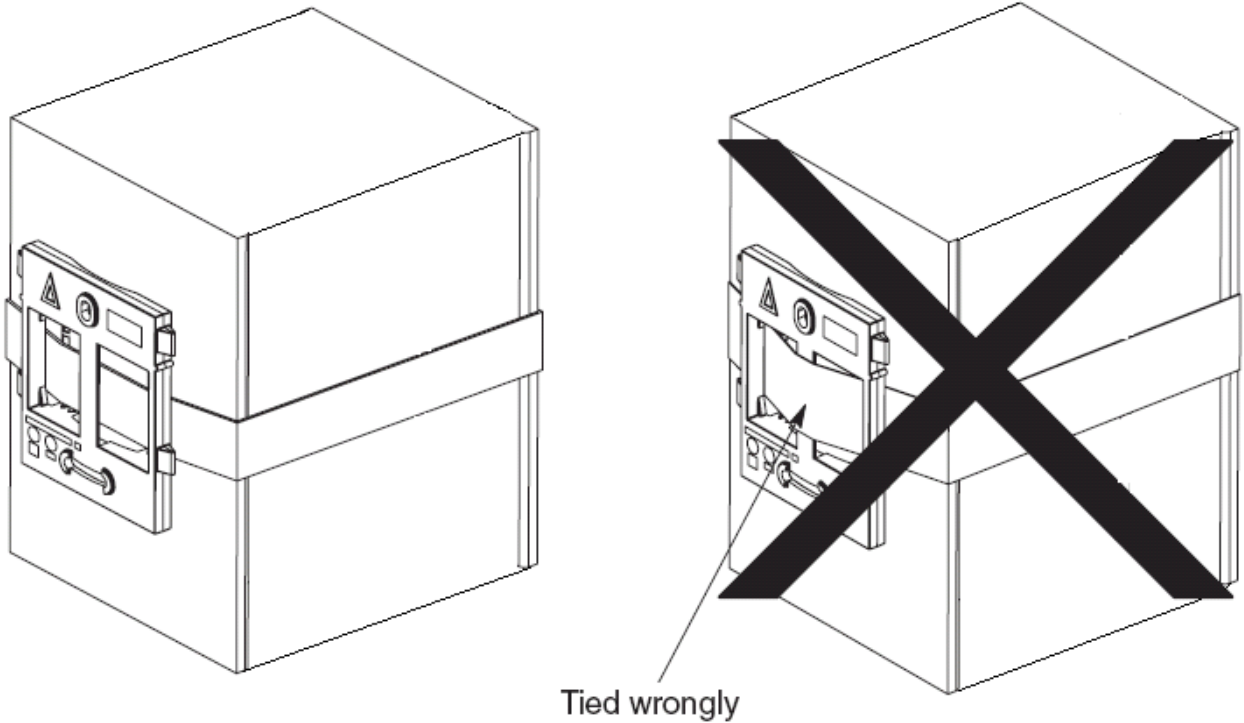

Note: Mounting a wireless base station directly on a steel beam or pillar could result in signal disruptions, such as dead zones or reflections. If it is absolutely necessary to mount the base station on a metallic surface, use spacers to separate the base station from the surface by 20-25 cm.

Chapter 6: IP Office User Features

For systems installed using IP Office provisioning, the IP Office system provides 3700 Series phone users with a range of additional IP Office specific features. These are in addition to the features detailed in the Avaya user guides for those phones.

For information on IP Office user features, see the following sections.

- [Idle Display](#) on page 110
- [Status Indicators](#) on page 111
- [Call Services](#) on page 112
- [In Call Options](#) on page 114
- [Call Waiting Options](#) on page 116

Idle Display

The phone idle display shows a number of information elements. They are, from top down:

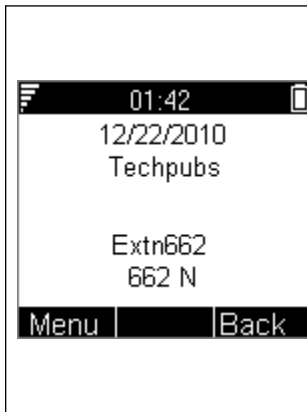

- The signal strength, time and battery charge. The battery charge will flash when below 5%.
- The date from the IP Office system.
- The name of the current subscription.
- The IP Office user name.
- The IP Office extension number and status indicators (see below).
- The soft key labels. The options here relate to the 3 buttons below the screen and change according according to the current phone state.

Status Indicators

The IP Office status indicators are shown after your extension number on the display. There may be more than one indicator shown. The possible status indicators are:

- **B = Barred**

A **B** is shown on your phone's display when the system administrator has set you to outgoing call barred status. You will only be able to make internal calls while this is applied.

- **D = Diverting (Forwarding) Calls**

A **D** is shown after your extension name on the phone's idle display when you have forward unconditional enabled.

- **G = Group Member (In Group)**

A **G** is shown after your extension name on the phone's idle display when have been configured as a member of a hunt group and your membership is enabled. While this is the case, you may receive calls targeted to the hunt group.

- **H = Held Call**

An **H** is shown after your extension name to indicate that you have a held call or calls on the IP Office system.

- **N = No Calls (Do Not Disturb)**

An **N** is shown after your extension name when you have do not disturb enabled.

- **O = Out of Service**

An **O** is shown on your phone's display when any of the groups of which you are enabled as a member is set to night service mode. In that mode calls to that group are diverted to its fallback if set or otherwise to voicemail if available.

- **P = Parked Call**

A **P** is shown after your extension name to indicate that you have a park call or calls.

- **T = Twinned**

A **T** is shown after your extension name on the phone's idle display if it is internally twinned with your deskphone. Calls to you will alert on both phones and can be answered by you at either phone.

- **R = Resilience**

An **R** is shown after your extension name on the phone's idle display your phone is working in resilience mode. This is used when there may have been a problem with the telephone system to which your phone was registered and another IP Office system is currently providing support for your phone. In this mode, some features may not be available and calls may be routed differently.

- **S = System Alarm**

If you are configured as a system administrator, an **S** in the phone's display indicates a system alarm. This is for information only, you are not expected to fix the alarm, just report it. (IP500 V2 only)

Call Services

The following options can be accessed when the phone is idle or the current call is parked or held.

1. Press **Menu**. Scroll the display to **☎ Calls** and press **Select**.
2. Scroll down to **Call services** and press **Select**.
3. The list of available services is displayed. Scroll to the required service and press **Select**.
4. For some functions you may need to enter additional data on the display or select from a list. Do this and press **OK**.
5. The phone sends the appropriate signals to the IP Office.
6. Hang up the call.

The available services are:

- **Call Pickup Any**

Answer the first available call ringing anywhere on the phone system (unless the call is on a private line). Details of the callers and the original call destination will be displayed.

- **Call Pickup**

You can use this option to answer a call ringing at another extension. Select the option and enter the extension number.

- **Call UnPark**

Retrieve a call from the parked state. To do this you need to enter the park slot number assigned to the call when it was parked. You can park a call using the Park Call option and assign it an park slot number at the same time that you or another user can then use to unpark the call.

- **Call Waiting Suspend**

You can use this option to temporarily switch off call waiting. It will remain off until the end of your next call. Use this when you do not want a call interrupted by call waiting tones.

- **Cancel Call Fwd**

You can use this option to switch off all your call forwarding. It does not affect the forwarding numbers, just your use of forwarding. If you have redirected your calls to another phone using follow me on that phone, this option also cancels the follow me feature.

- **Do Not Disturb On**

You can use this option to switch do not disturb on. Calls to you go to your voice mail mailbox if available, otherwise they receive busy. They do not follow any forwarding settings.

A N for no calls is shown on the phone's idle screen when you have do not disturb switched on.

- Some numbers can be configured as do not disturb exceptions. You can do this using the one-X Portal for IP Office application or from the menu of some desk phones (contact your system administrator for details). Those numbers are able to call you and transfer calls to you while you have do not disturb switched on.

- **Do Not Disturb Off**

You can use this option to switch do not disturb off. When off, calls will alert the handset and or follow your forwarding settings.

- **Fwd Unconditional On**

You can use this option to switch immediate call forwarding on. A forwarding number needs to be set for this to work, use the **Fwd number** call service to see and edit your current forwarding number. By default internal and external calls to you are forwarded but hunt group calls are not. However the settings for internal and hunt group calls can be adjusted by your system administrator. To switch off forwarding, use **Cancel All Fwd**.

- **Fwd Busy On**

You can use this option to switch on forwarding of any additional calls when you are already have a call connected. If you have call waiting enabled, it is used for additional calls when you already have a call connected and another one waiting. To switch off forwarding, use **Cancel All Fwd**.

- **Fwd No Answer On**

You can use this option to forward any call that rings the handset without being answered. To switch off forwarding, use **Cancel All Fwd**.

- The default no answer time used to trigger the forward is 15 seconds. However this time can be adjusted by your system administrator if required.
- If you use voicemail, the forward is used first. However if the call is still unanswered, the phone system will still attempt to redirect the call to voice mail. This may not be possible for calls forwarded to external numbers.

- **Fwd Number**

You can use this option to see and set the number to which your calls are forwarded when you select **Fwd Unconditional On**. If your system uses an external dialing prefix, remember to include it if you want to forward calls to an external number. However, note that external forwarding may be restricted by your system administrator. This number is also used for **Fwd Busy On** and **Fwd No Answer On** unless you set a separate **Fwd Busy Number**.

- **Fwd Busy Number**

You can use this option to see and set the number to which your calls are forwarded when you select **Fwd Busy On** and or **Fwd No Answer On**. If your system uses an external dialing prefix, remember to include it if you want to forward calls to an external number. However, note that external forwarding may be restricted by your system administrator. To switch off forwarding, use **Cancel All Fwd**.

- **Follow Me Here On**

If you are a temporary user of the phone, you can use this option to have calls to your desk phone redirected to the handset. Select this option and enter your extension number.

- **Follow Me Here Off**

To end a follow me set using **Follow Me Here On**, select this option and enter your extension number. Calls to that number will no longer be redirected to the handset.

- **Login**

Users with a login code can 'hot desk', that is login at any phone on the system and, when finished making or taking calls, log out. While logged in on a phone, that phone adopts all their user settings and their calls are routed to it. This option can be used in a number of ways.

- The DECT handsets can be configured with no permanently associated user. To use the phone, you need to login using your extension number and login code.
- The DECT handsets can be configured with an associated user. However, you can use log in and log out as a method of security for your phone.
- Other users can use their log in code when they temporarily need to use your handset as their own phone. While they do this you are logged out.
- Note that SMS messaging, provided by the AIWS, always goes to the same original handset even when the associate user hot desks to another handset.

- **Logout**

If you have a login code, you can log out of the phone you are currently using. When you log out, if you are normally associated with another phone, you are automatically logged back in on that phone unless someone else is using it or you are set to forced login. If you are not automatically logged in elsewhere, then while logged out your are treated as being busy to all calls. Instead your calls go to voice mail if available.

In Call Options

During a call, the **More** soft key can be used to access a number of handset and IP Office functions while still remaining connected to the call.

1. During the call, press **More**.
 - If the phone is not currently on the call details screen, you may have to press **Back** to get to that screen before you can press **More**.
2. Select the function required.
3. Some functions may require you to enter some data, for example the destination for a transfer.

The possible functions are:

- **Auto Callback**

If you are making a call to another extension and it has not been answered, setting a callback tells the phone system to ring you when that extension finishes its next call. When you answer the target extension is rung again.

- **Call Park**

You can use this option to park your current call. You can enter a park slot number which is then useable by anyone else on the system to unpark the call.

- If you do not enter a park slot number when parking a call, one is automatically assigned using your extension number plus a digit 0 to 9.
- When you park a call, a **P** is shown on your phone's idle display until the call is unparked or the caller hangs up.
- Parked calls automatically re-ring you if left parked for too long (the default time is 5 minutes).

- **Clear Call**

Use this option to end the current call and answer a held call. This may be useful when trying to transfer a held call and you find yourself connected to the transfer destinations voicemail or busy tone. Similarly you can use it when trying to add another party to a conference if the other party does not answer or does not want to be part of the conference.

- **Clear Call Waiting**

You can use this option to end your current call and automatically answer the waiting call.

- **Conference Add**

You can use this option to start a conference with the current call and any calls you currently have on hold. The conference is automatically assigned a conference number that is shown on the display.

To add another party to the conference, press **R** to put your connection to it on hold and dial the other party. When answered select **More > Conference Add**.

Note: This menu option is *only* available on DECT phones that were configured during a provisioned installation. If you performed a non-provisioned installation, you will require a short code (*47) menu item to invoke the Conference Add feature.

- **Hold Call Waiting**

You can use this option to put your current call on hold and automatically answer the waiting call.

- **Call Record**

You can use this option to switch on call recording if your phone system includes IP Office VoiceMail Pro.

- **Microphone Off**

You can use this option to turn the handset's microphone off. A  icon is displayed on the call details screen. The microphone is automatically re-enabled when you next make or answer a call.

- **Microphone On**

You can use this option to turn the handset's microphone back on if you have turned it off during the call.

Call Waiting Options

By default call waiting is turned on for all users. On the DECT display with a call already connected, another incoming call will cause you to hear a single beep and the phone display will alternate between details of your current call and the waiting call.

You can only have one connected call plus one waiting call. Any further calls will see you as being busy and will either follow your forward on busy settings if set or else go to voicemail if available. If you don't answer the waiting call, it will follow your forward on no answer settings if set or else go to voicemail.

If you end your current call while you have a call waiting, the waiting call will start ringing and can be answered. You can end your current call and automatically answer the waiting call by using the Clear Call Waiting option. You can hold your current call and automatically answer the waiting call by using the Hold Call Waiting option.

Chapter 7: Device Management

This section covers the use of the Device Management application to update the firmware on the phones and to apply customized features templates to the phones.

There are two variants of the device management application that can be used. They look similar and offer the similar features but operate differently:

- **AIWS Device Manager**

This is a version of the device manager application embedded into the AIWS unit. It can be started via browser access to the AIWS unit rather than having to be installed on a particular PC.

- **WinPDM (Windows Portable Device Manager)**

This is a version of the device manager application that can be installed onto a Windows PC.

The use of templates is not supported for systems installed and maintained using IP Office provisioning. With provisioned systems, device management should only be used for updating handset firmware.

Starting AIWS Device Manager

Procedure

1. Enter the IP address of the AIWS into the browser address field.

Alternatively enter `http://Elise-0091921` as the address, replacing the digits with the AIWS unit's Module Key. The Module Key is printed on the AIWS circuit board

2. If a security certificate warning appears, select it to continue.
3. Enter a user name and password. The default values are **admin** and **changeme**.

The AIWS menu is shown:

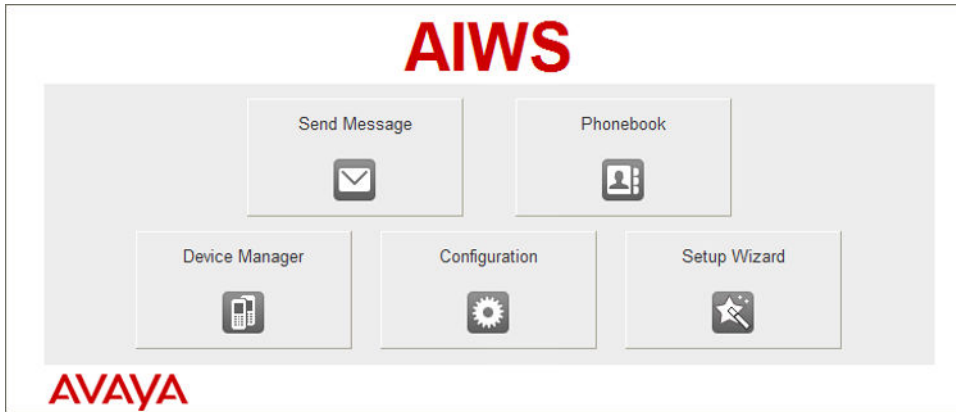

Loading Parameter Definition Files

About this task

The parameter definition files supplied with the DECT R4 software include software files used to update the phone software. These files must be uploaded to WinPDM in order to allow phones to be upgraded.

Procedure

1. Start the AIWS Device Manager or Windows Device Manager.
2. Select **File | File management**.

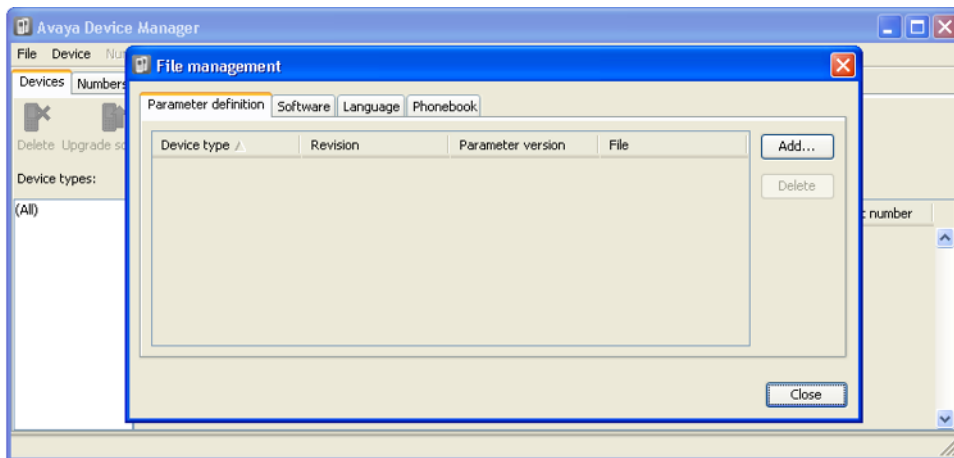

3. Select the **Parameter definition** tab. Click **Add**.
4. Browse to the `Handsets` folder in the software previously unpacked. Select the `.pkg` files in the folder and click **Open**.

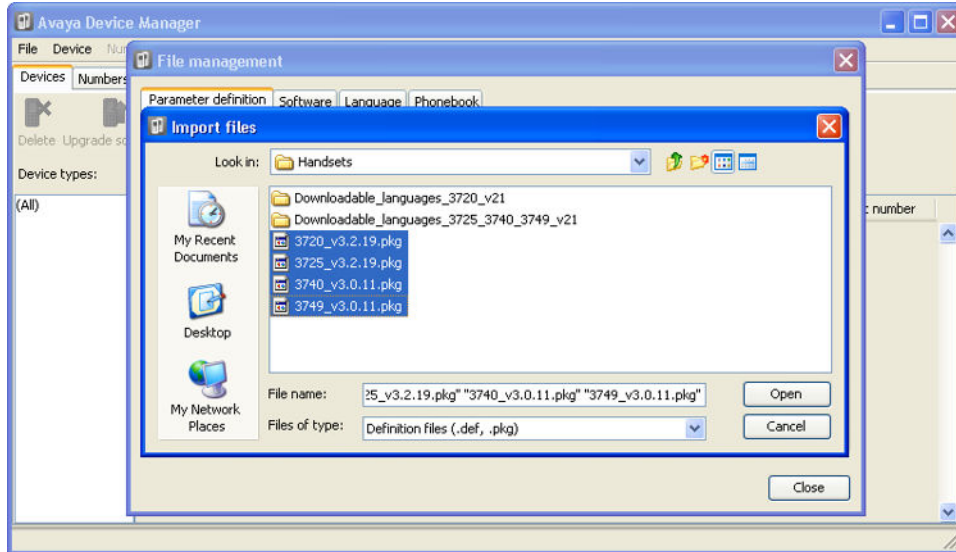

5. Click **Add...**
6. Browse to the **Chargers** folder in the software previously unpacked. Select the **.pkg** files in the folder and click **Open**.

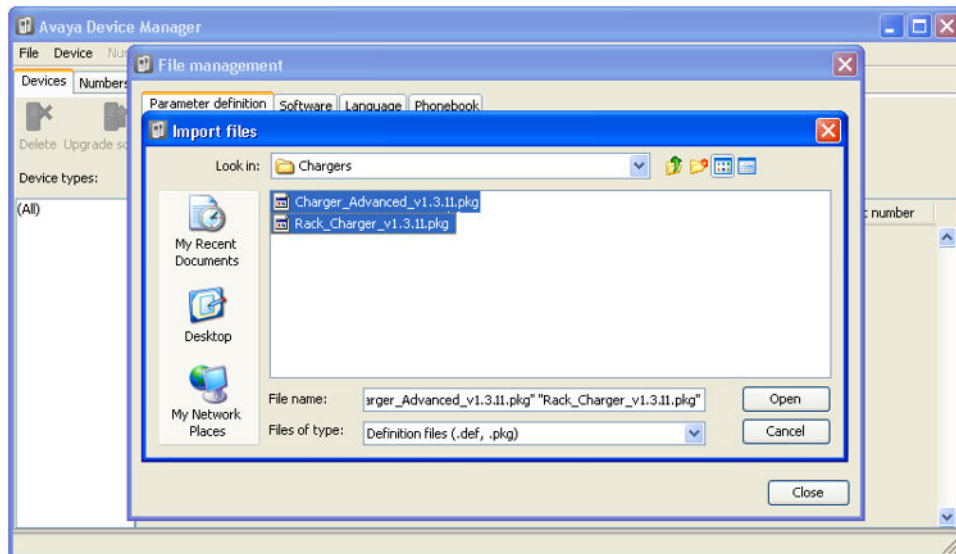

7. The list of parameter definition files should now be complete.

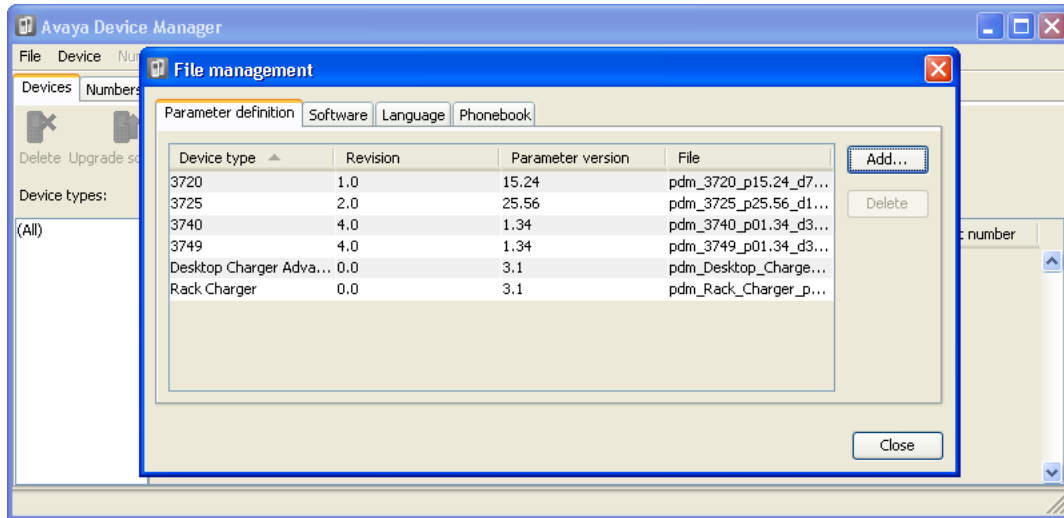

8. Select **Close**.

Loading Phone Templates into Device Manager

About this task

Templates allow you to apply common settings to phones and chargers. The IP Office DECT R4 software set includes default templates for 3700 Series phones that allow those phones to access IP Office functions through the phone menus.

The use of templates is not supported for systems installed and maintained using IP Office provisioning. With provisioned systems, device management should only be used for updating handset firmware.

Procedure

1. Select the **Devices** tab. The phones subscribed to the DECT system should be listed.

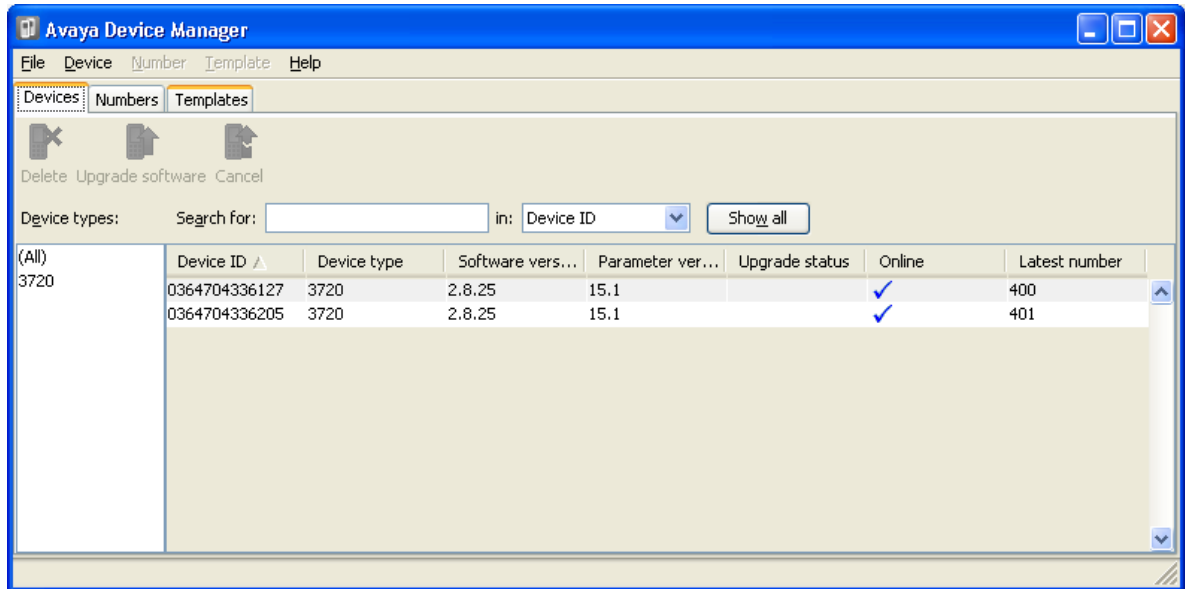

2. Select **File | Import | Templates...**

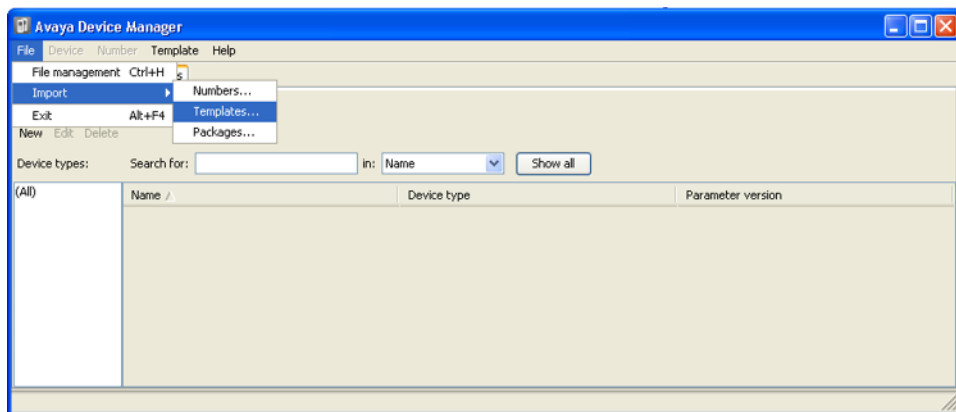

3. Browse to the previously unpacked software and select the **.tpl** template files.

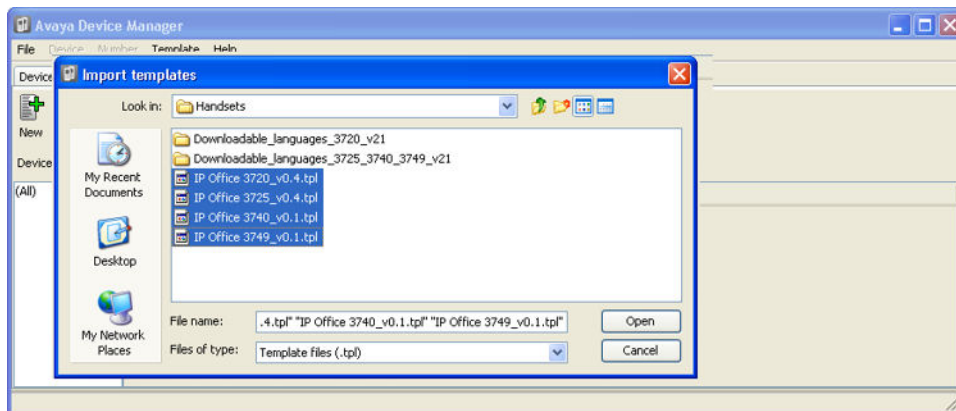

4. Click **Open**. The template files are loaded into Avaya Device Manager.

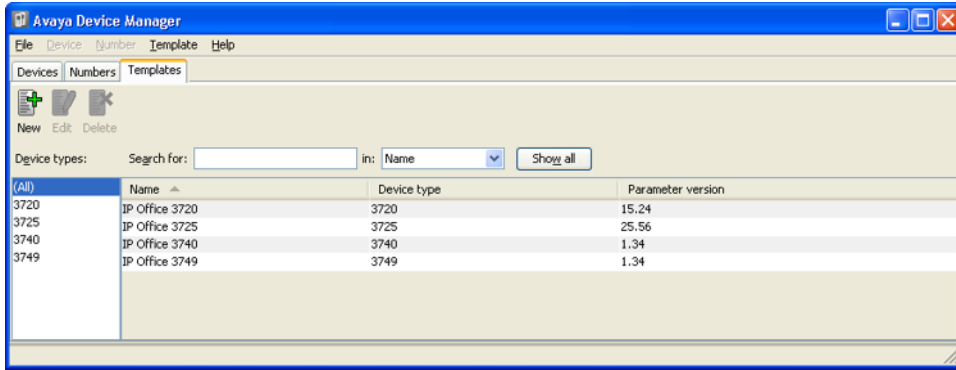

Applying Templates to Phones

About this task

The use of templates is not supported for systems installed and maintained using IP Office provisioning. With provisioned systems, device management should only be used for updating handset firmware.

Procedure

1. Within the Avaya Device Manager, select the **Templates** tab.
2. Right-click on the template and select **Apply to....**

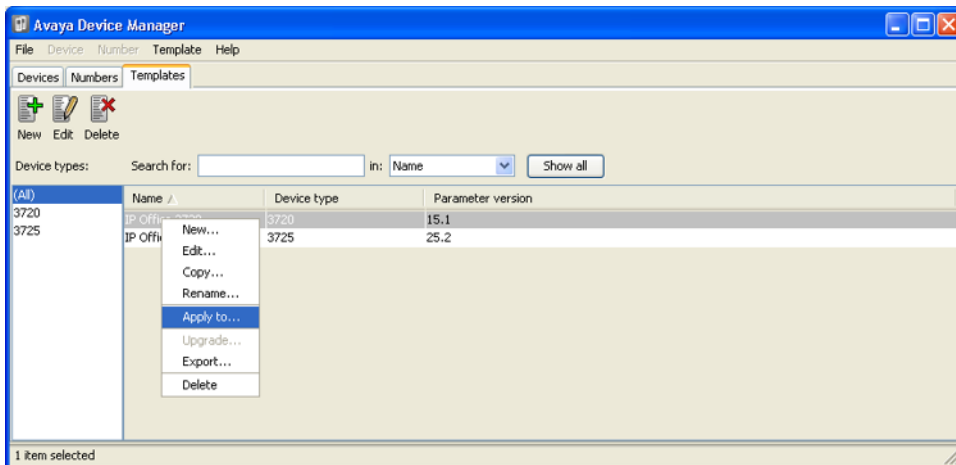

3. Select the phones to which you want the template to be applied. Click **OK**. The phones will begin uploading the template file.

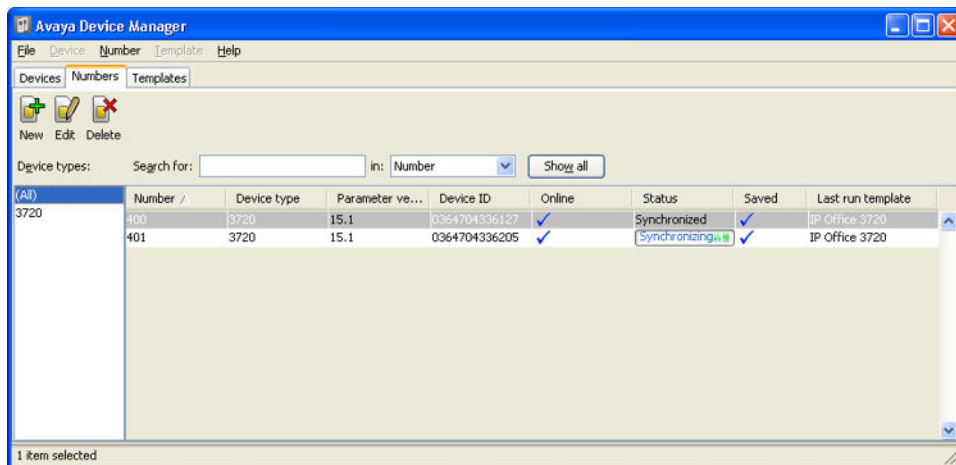
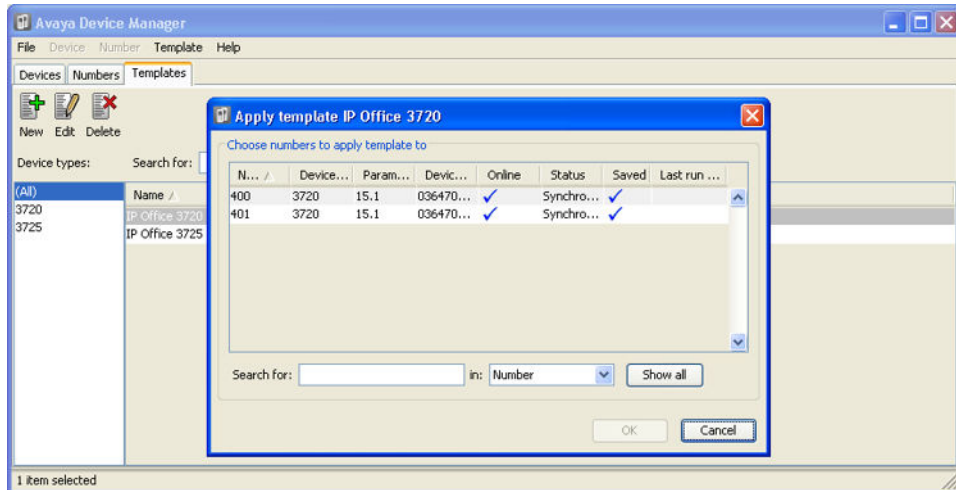

Editing Templates

Procedure

1. Within the Avaya Device Manager, select the **Templates** tab.
2. Right-click on the template and select **Edit**. Alternatively to create a new template, right-click on the template and select **Copy** and enter a new name for the new template.

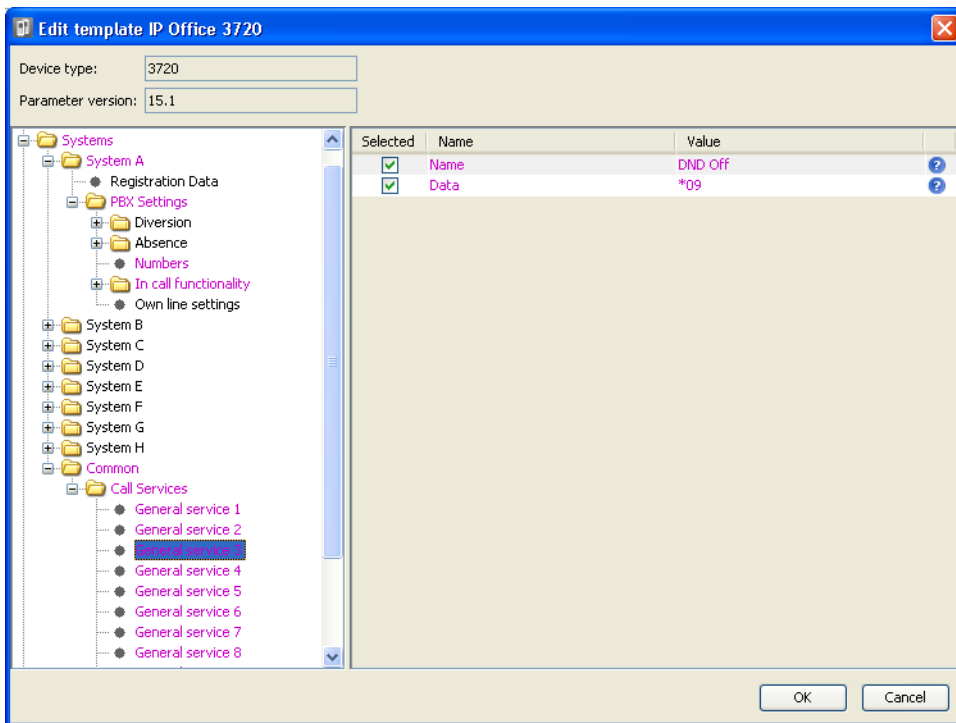
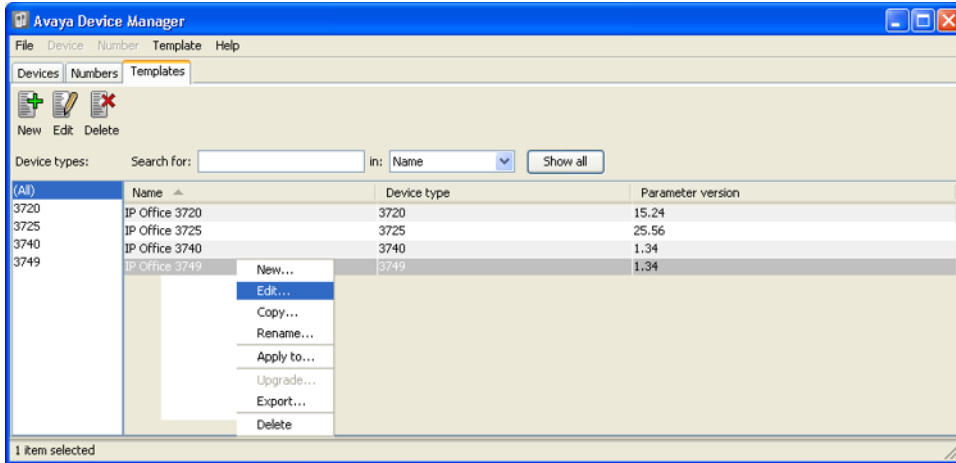

- **Systems | System A | PBX Settings | In call functionality**

Defines the options shown on the **More** menu shown on 3700 Series phones when on a call. This can be used to enter the IP Office short codes for functions such as call park, conference and transfer.

- **Systems | Common | Call Services**

Defines the options shown on the 3700 Series phone Call Services menu. This can be used to enter the IP Office short codes for functions such as call pickup, DND on/off.

- The items shown in pink indicate areas of the template that contains settings selected to be applied to the device when the template is uploaded to the device. Items shown in blue have been changed during this editing session.

- **Black:** Normal
- **Dark Blue:** Parameter has been edited during the current session.
- **Purple:** The parameter is enabled in the template.
- **Red:** Value not valid.
- **Turquoise:** The value differs from the default value
- Each item within the template consists of three parts:
 - **Selected** - If selected, the template value will be applied to devices to which the template is uploaded.
 - **Name** - The non-editable name for the template item.
 - **Value** - The value for the template item. This may be a drop-down list from which selection can be made.
- Click **OK**.

Upgrading Phone Software

About this task

DECT R4 is supported on a range of Avaya systems. However, for IP Office operation, only software specifically documented as having been tested and supported with IP Office should be used. Details of supported software for any particular IP Office release is included in the IP Office Technical Bulletin for that release.

Installing Windows Device Manager to Upgrade Phones

About this task

As an alternative to the Device Manager application integrated into the AIWS unit, a copy of Windows Device Manager can be installed onto a Windows PC (Windows XP or Vista).

Procedure

1. Browse to the location where you unpacked the IP Office software for DECT R4. Locate the `Avaya WinPDM` folder.
2. Double-click on **Setup.exe**.

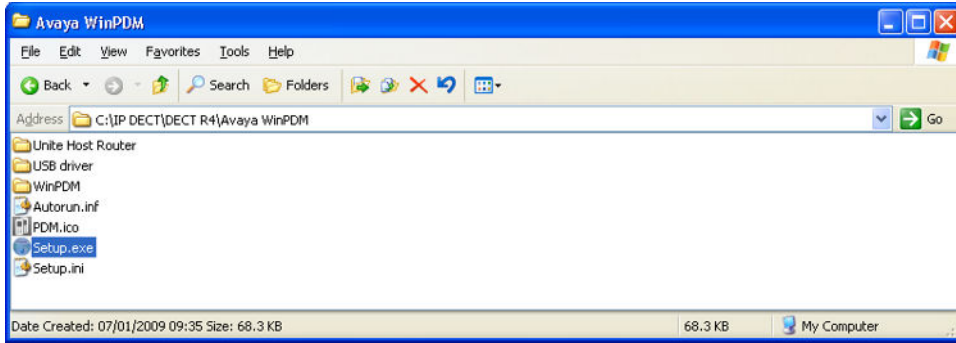

3. Click **Next**.



4. Select **Avaya WinPDM** and click **Next**.

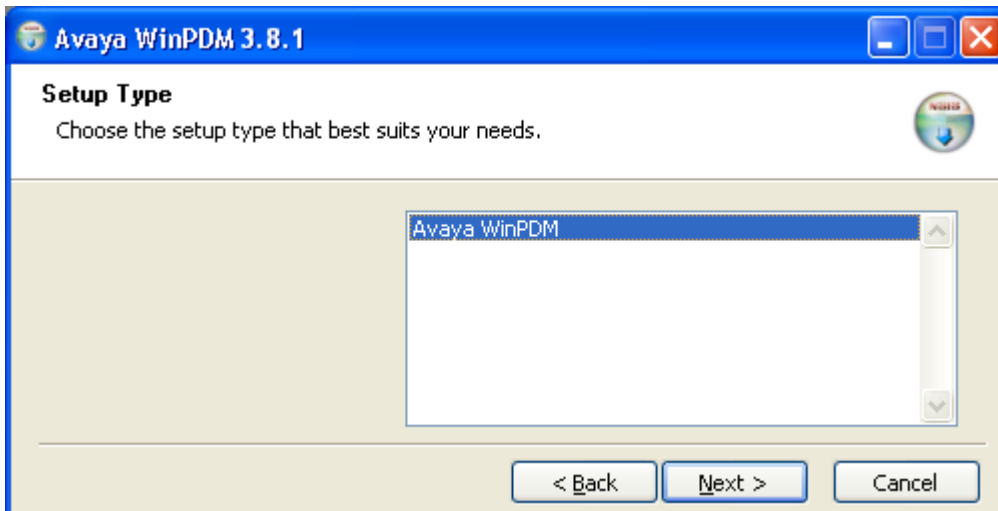

5. Click **Install**.

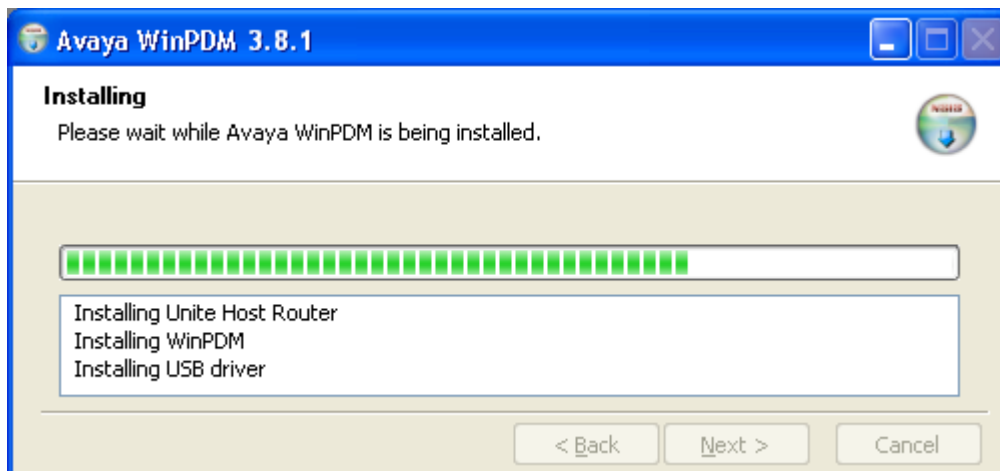
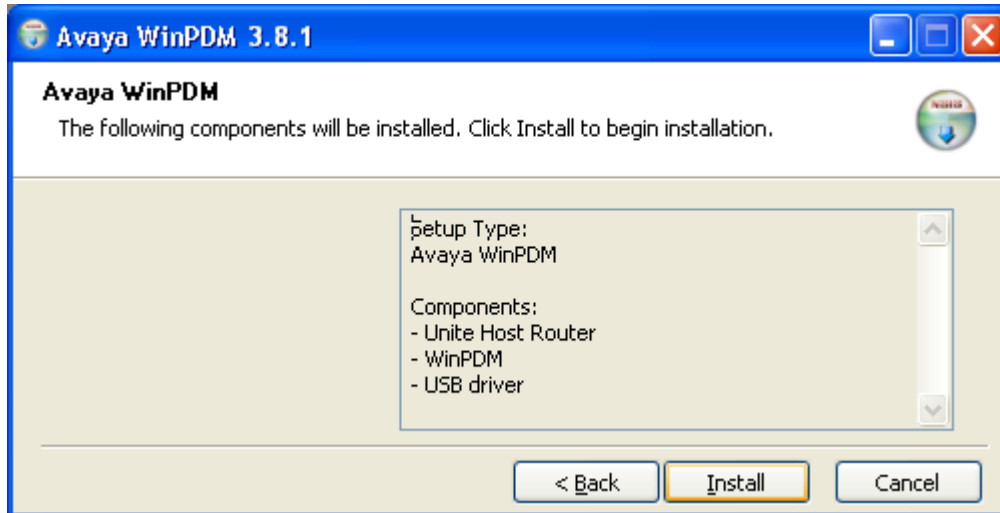

6. When the installation is complete, click on **Finish**.

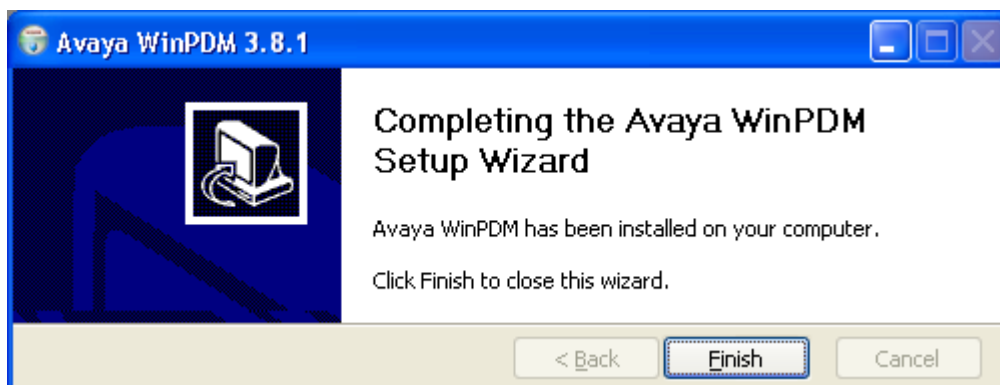

Starting Windows Device Manager

Procedure

1. Select **Start | All Programs | Avaya WinPDM**.
2. Click on the **Avaya WinPDM** icon.
 - If this is the first time that Avaya WinPDM has been run, you will be asked to create a site. Enter a name for the site that you have been installing and click **OK**.
 - If this is the first time that Avaya WinPDM has been run, you will be prompted to import parameter definition files.

Upgrading Phone Software

About this task

DECT R4 is supported on a range of Avaya systems. However, for IP Office operation, only software specifically documented as having been tested and supported with IP Office should be used. Details of supported software for any particular IP Office release is included in the IP Office Technical Bulletin for that release.

Procedure

1. Within the Avaya Device Manager, select the **Devices** tab.

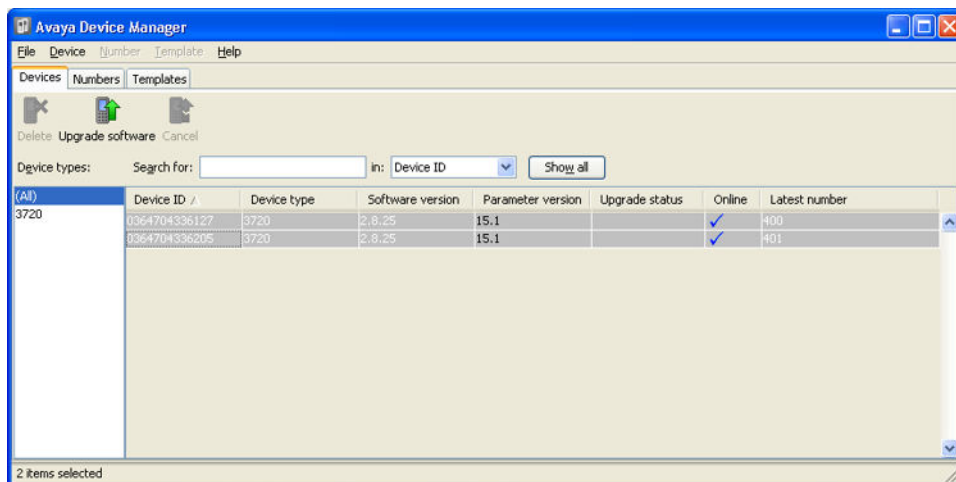

2. The current software version of each phone is shown. Compare this to the software versions available, shown by the version set as part of the .pkg file name included with the DECT R4 software.

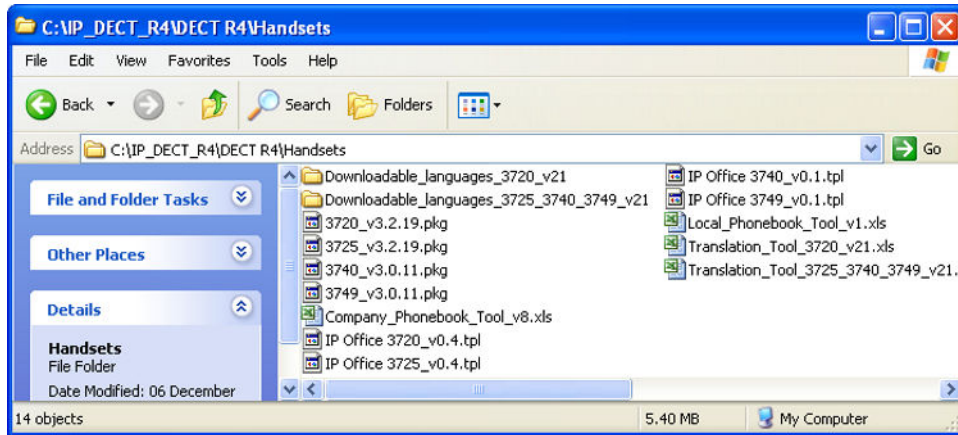

3. In the device manager, select the phones that you want to upgrade.
4. Click **Upgrade Software**. The menu shown will depend on whether you are using the AIWS for an over the air upgrade or WinPDM for an in charger upgrade.

- **AIWS Upgrade Software Menu**

This menu is shown when using the AIWS based device manager to upgrade phones over the air. This method supports a number of additional options but is much slower than upgrading phones in an advanced charger.

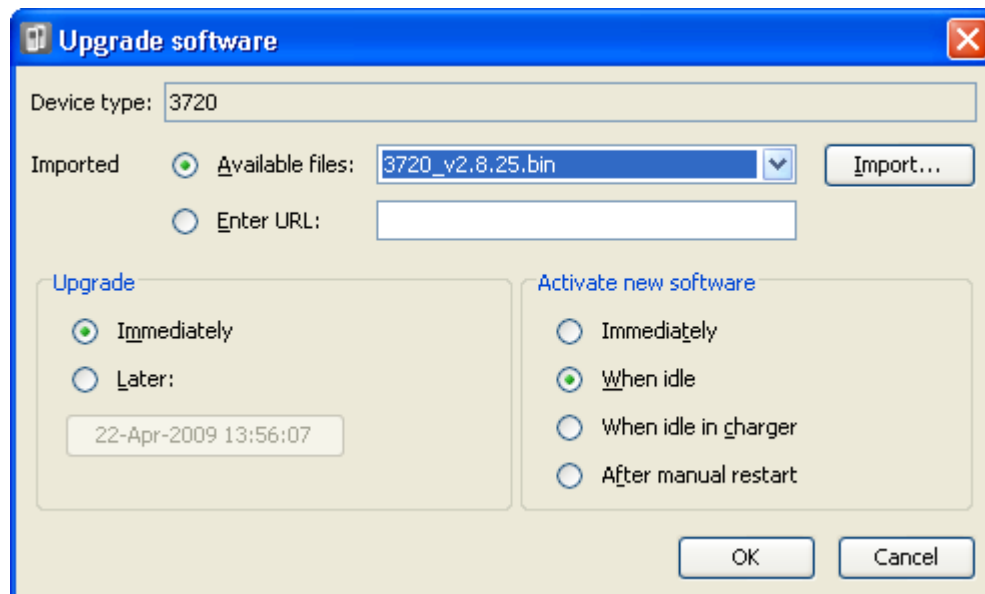

- **Advanced Charger/WinPDM Upgrade Menu**

This menu is shown when using the Windows based device manager to upgrade a phone currently in an advanced charger connected to the PC by USB or LAN. See [Installing Windows Device Manager](#) on page 90.

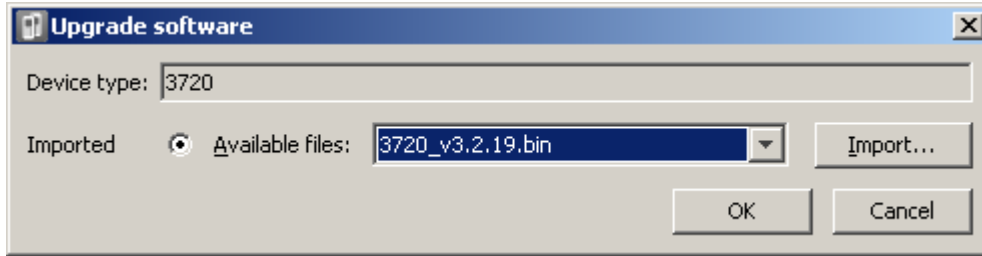

- If you have already imported the parameter definition files for the phones, use the **Available Files** drop-down to select the software bin file for the type of phone being upgraded. Otherwise click on **Import** and browse to the .pkg files for the phone type.
- Select the other upgrade settings required and click **OK**.

The upgrade begins. The following images show a typical upgrade as it is being performed on a 3720 device.

(All)	Device ID /	Device type	Software version	Parameter version	Upgrade status	Online	Latest number
3720	0364704336127	3720	2.8.25	15.1	Downloading	✓	400
	0364704336205	3720	2.8.25	15.1	Downloading	✓	401

(All)	Device ID /	Device type	Software version	Parameter version	Upgrade status	Online	Latest number
3720	0364704336127	3720	2.8.25	15.1	12%	✓	400
	0364704336205	3720	2.8.25	15.1	12%	✓	401

(All)	Device ID /	Device type	Software version	Parameter version	Upgrade status	Online	Latest number
3720	0364704336127	3720	2.8.25	15.1	Complete	✓	400
	0364704336205	3720	2.8.25	15.1	Complete	✓	401

Chapter 8: AIWS Installation

Pre-Requisites

- Master base station installed and connected to the network.
- IP Office connected to the network.
- Phones subscribed.

Parts Required

- AIWS Unit which includes:
 - AIWS Unit
 - AIWS Power Supply unit and selection of IEC60320 C7 power leads (CEE7/16 (Europlug), BS1363, NEMA1-15 and AS/NZS 3112).
 - 1.2 metre (4 foot) LAN cable
If this is replaced with a longer cable the replacement should be a CAT5 Ethernet LAN cable.
 - AIWS License sheet.
 - 3 x 3.5mm Screws and suitable wall plugs for the wall mounting of the AIWS.
 - LAN Socket
 - Mains power outlet socket.

Information

- IP Address for the AIWS.
- Other standard network settings (Default Gateway, DNS, WINS).
- AIWS License Key (this should have been supplied with the AIWS).
- IP Address of the DECT Master base station.
- IP Address of the IP Office.
- Preferred time settings (date format, time format).
- Wall mounting location selected for the AIWS.

- Access information (name and password) for configuring the base stations.

Tools

- Programming PC with DECT R4 software.
- Web browser.
- Pliers and sharp knife for removal of plastic cable cut-outs from AIWS case.
- Drill and drill bits suitable for the selected wall mounting position of the AIWS.
- Screwdrivers for use with the screws selected for AIWS wall mounting.

Installing an AIWS1

About this task

The AIWS (*Avaya In-Building Wireless Server*) unit allows SMS messaging between handsets. It also allows wireless software upgrades and configuration of the handsets. Without an AIWS, handsets can only be upgraded and configured when in an advanced charger or a rack charger.

For IP Office Release 5 this unit also provides directory integration between the IP Office and the DECT R4 system.

For IP Office Release 6 and later, directory integration is done by the master base station when the AIWS is not present. However, an AIWS is still required for both functions if SMS is needed.

The unit is managed by means of a web browser and requires a fixed IP address.

The AIWS installation consists of the following stages:

Procedure

1. [Removing the AIWS Cover](#) on page 134
2. [Connect the RTC Battery](#) on page 136
3. [Connecting LAN and Power Cables.](#) on page 136
4. [Accessing the AIWS Interface](#) on page 137
5. [Running the Setup Wizard](#) on page 138
6. [Enabling the Base Station AIWS Connection](#) on page 144
7. [Upgrading the AIWS Firmware](#) on page 146
8. [Switching Off the AIWS](#) on page 152
9. [Wall Mounting the AIWS](#) on page 152
10. [Replacing the AIWS Cover](#) on page 153

Image Installation Mode

About this task

This is the maintenance process to put an AIWS into Image Installation mode. The maintenance process is used to upload a .img file to the AIWS1 unit.

Procedure

1. Remove the AIWS cover.
2. To set the AIWS to Image Installation mode:
 - a. Looking at the AIWS without the cover, the status LED should be towards the upper right corner.
 - b. Beneath it there should be two rows of small switches, to the right of the round battery.
 - c. The bottom one is of interest, as a way of being sure there should be a mark on the board right next to it saying **SW3**.
 - d. All the switches should be marked with numbers in range 1 to 8, there should also be a mark **.ON**.
 - e. Set only the switch labeled 4 to **ON**, the rest to **OFF**.
 - f. From the browser make a reboot of the AIWS.
 - g. If unable, there is another way: press the small button above and a bit to the left of the round battery on the AIWS circuit board.
 - h. The press does not have to be long, a short one will do.
 - i. There is a 10 minute waiting time when doing so, in addition to the actual shutdown and startup of the AIWS.
 - j. The reboot from the browser does not have this waiting time, so it is preferred.
 - k. Access the AIWS through the web browser. Do not type https in the address bar in image installation mode, as it only works with http.
 - l. Select the image file and upload it.
 - m. Set the AIWS back to normal mode.
 - n. Set the switch labeled 4 back to OFF to be the same as the rest.
 - o. Reboot the AIWS, preferably from the browser again.
 - p. You must reconfigure the AIWS settings. Although the IP address should have not been changed, if having trouble accessing it try:
 - q. Setting the AIWS in network mode by turning the switch labeled 1 to ON
 - r. Reboot the AIWS.
 - s. The status LED should be steady amber (not blinking at all).

- t. Access the AIWS by the reserved IP address **192.5.36.229**.
- u. Enter the desired IP settings.
- v. Set the AIWS into normal mode by turning switch **1** back to **OFF**.
- w. Reboot the AIWS
- x. Access the AIWS using the newly entered LAN settings.

Removing the AIWS Cover

About this task

The AIWS cover can be removed without using any tools.

Procedure

1. On the base of the unit (opposite the rounded end) are two depressible clips. Depress these while lifting the cover.
2. It should be possible to lift the cover off the unit.

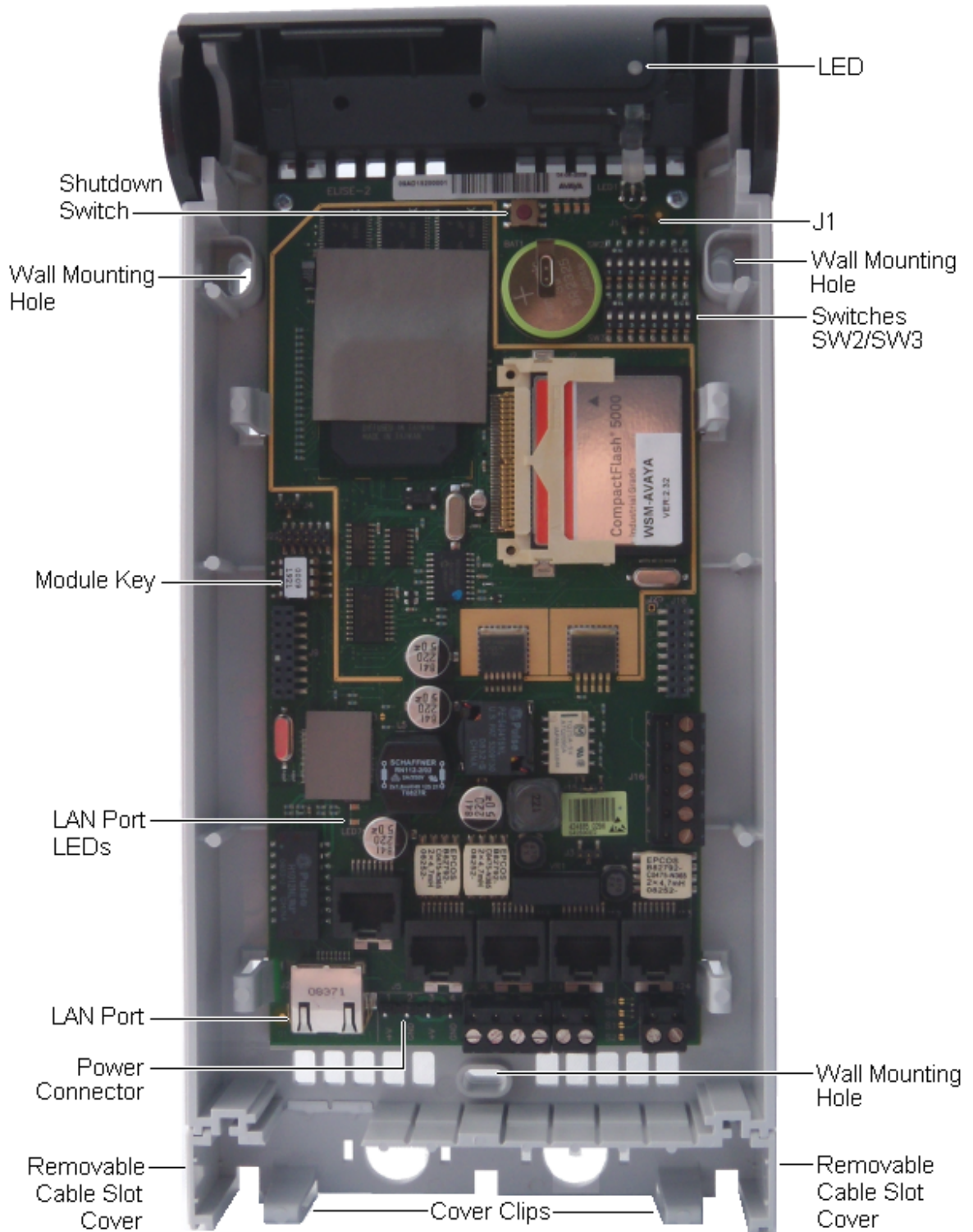

3. With the cover removed, familiarize yourself with the various features labeled above. These will be referred to during other parts of the installation process.

Connecting the RTC Battery

The AIWS circuit board includes a 3V lithium battery which will keep the boards real time clock (RTC) running when power to the AIWS is off. The AIWS is shipped with the battery disconnected. To connect the battery, locate the switch **J1** at the top right of the board. Move the switch jumper to position 2-3.

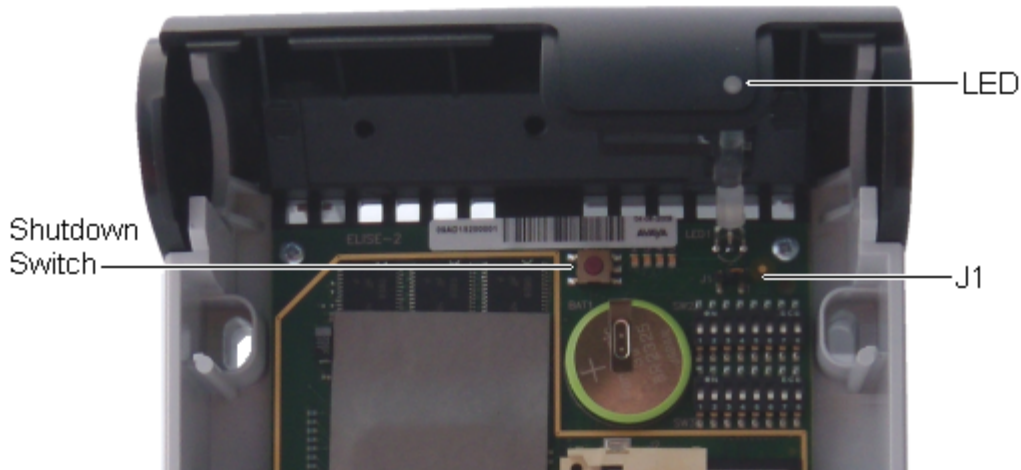

Connecting Cables to an AIWS

Procedure

1. Locate the switch sets **SW2** and **SW3** at the top-right of the AIWS circuit board. Ensure that all the switches are set to **Off**.
2. Locate the LAN port and the J5 power connector. Just below these is a plastic panel. With care remove sufficient parts of the panel to allow cable access to the LAN port and power connector when the AIWS cover is put back.

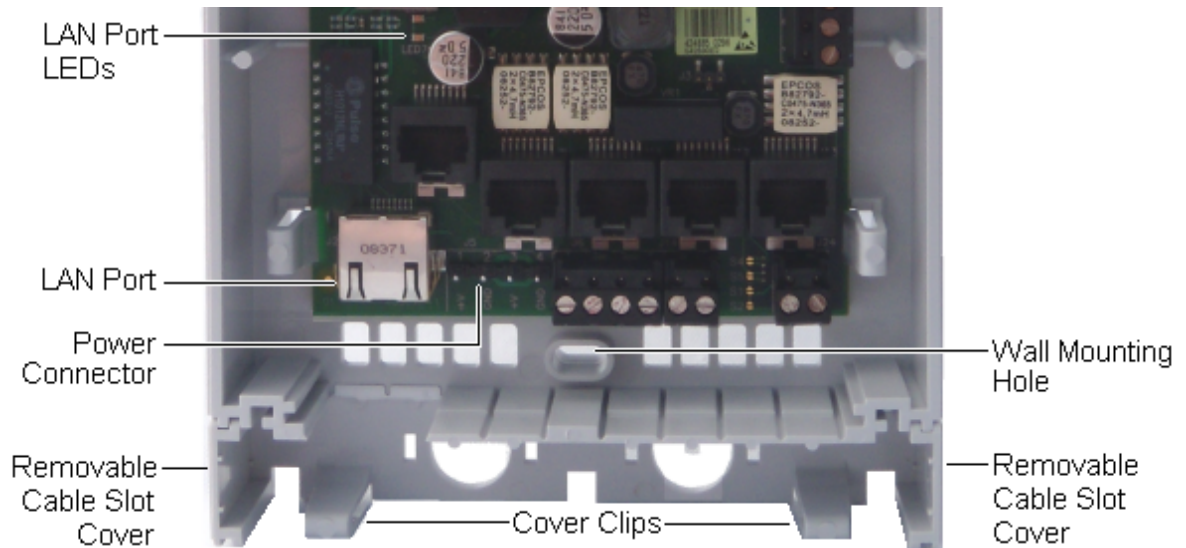

3. Connect the LAN cable from the IP Office to the AIWS.
4. Connect the power supply cable to the J5 power connector next to the AIWS LAN port.
5. Switch on power to the AIWS unit.

Accessing the AIWS Interface

About this task

The AIWS can be accessed using a web browser.

Procedure

1. Enter the IP address of the AIWS into the browser address field.
 Alternatively enter `http://Elise-0091921` as the address, replacing the digits with the AIWS unit's Module Key. The Module Key is printed on the AIWS circuit board.
2. If a security certificate warning appears, select it to continue.
3. Enter a user name and password. The default values are **admin** and **changeme**.

The AIWS menu is shown:

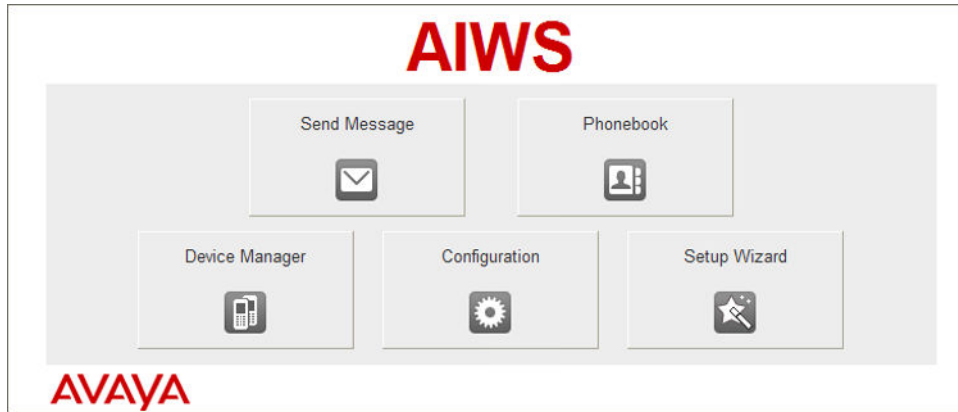

Running the Setup Wizard

About this task

The first time the AIWS is accessed it runs the setup wizard.

Procedure

1. Access the AIWS using your browser.
2. If the unit is defaulted, the setup wizard runs automatically. If the unit already has configuration settings, then from the menu displayed select **Setup Wizard**.

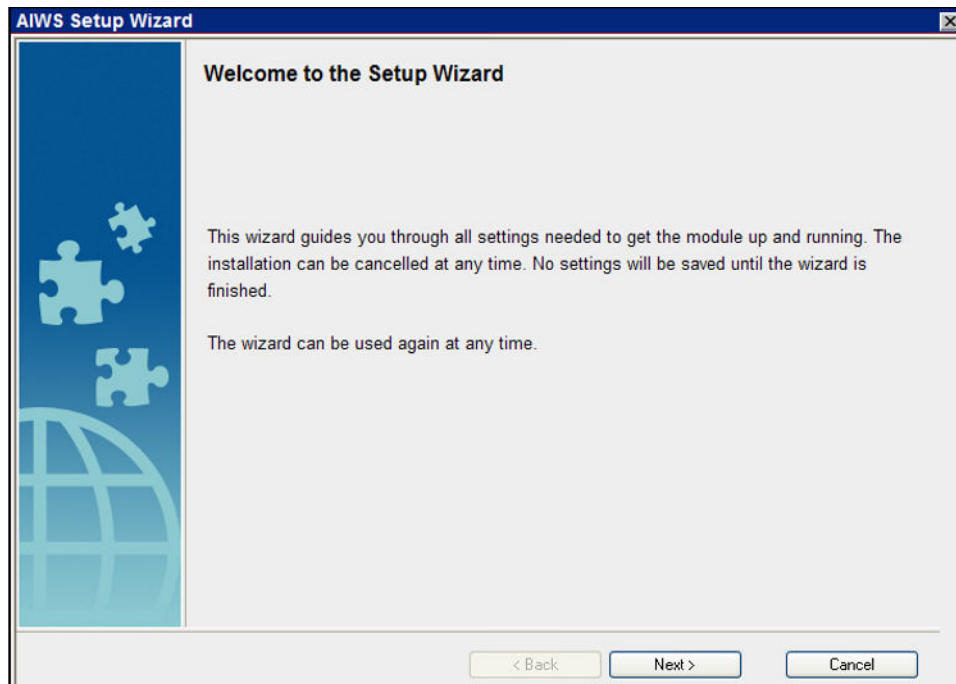

3. Click **Next**.

4. Enter the network address settings for the AIWS unit.

AIWS Setup Wizard

Network Setup

In a system with a DHCP server, the network parameters can be set automatically, otherwise the parameters have to be set manually.

Select how to set the network parameters

Automatically (DHCP)

Manually

Network Parameters

Host Name	<input type="text" value="AIW"/>	?
IP Address	<input type="text" value="192.168.42.211"/>	?
Subnet Mask	<input type="text" value="255.255.255.0"/>	?
Default Gateway	<input type="text" value="192.168.42.1"/>	?
Domain Name	<input type="text" value="example.com"/>	?
DNS Server	<input type="text" value="192.168.42.1"/>	?
WINS Server	<input type="text" value="0.0.0.0"/>	?

< Back Next > Cancel

- Set the network parameters mode to **Manually**.
- **Host Name**
Enter a name to help identify the AIWS on the network.
- **IP Address/Subnet Mask**
Enter the static IP address details that the AIWS should use.
- Set the remaining details to match those being used by other devices on the network.
- Click **Next**.
- Enter the license number supplied with the AIWS unit and click **Next**.

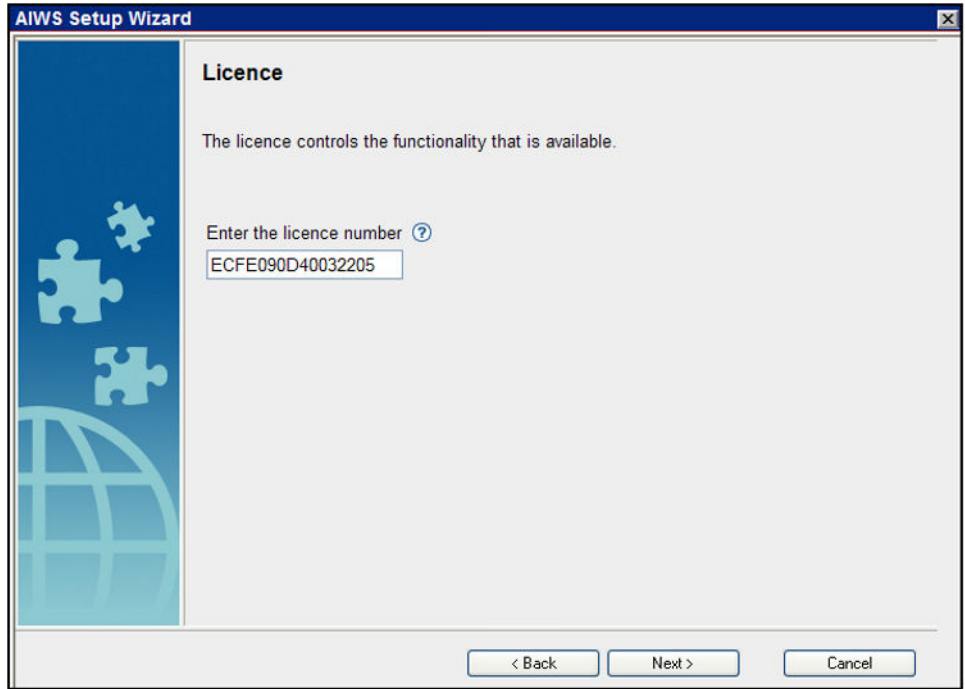

- Enter the IP address of the master base station and click **Next**.

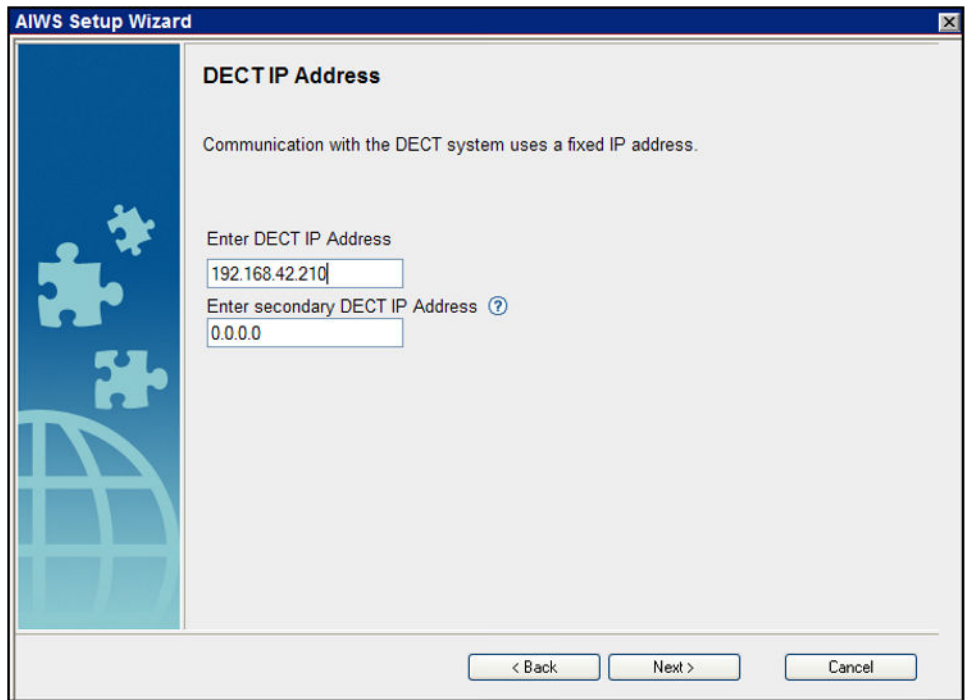

- The **Date and Time** options are displayed. Select **NTP Time Server** and set the **Time Server IP Address** to be the IP address of the IP Office. Adjust the other values to match the customer site.

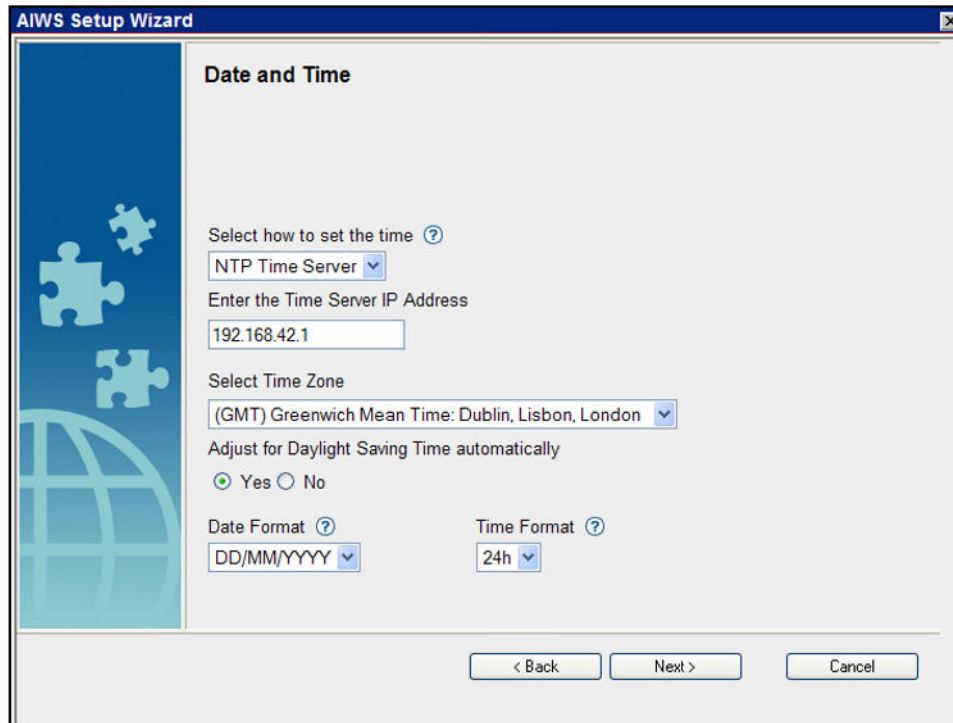

- Click **Next**. The **Phonebook Properties** options are displayed.
- Select **TFTP**, in order to have the AIWS obtain the phone book from the IP Office, and then click **Next**.

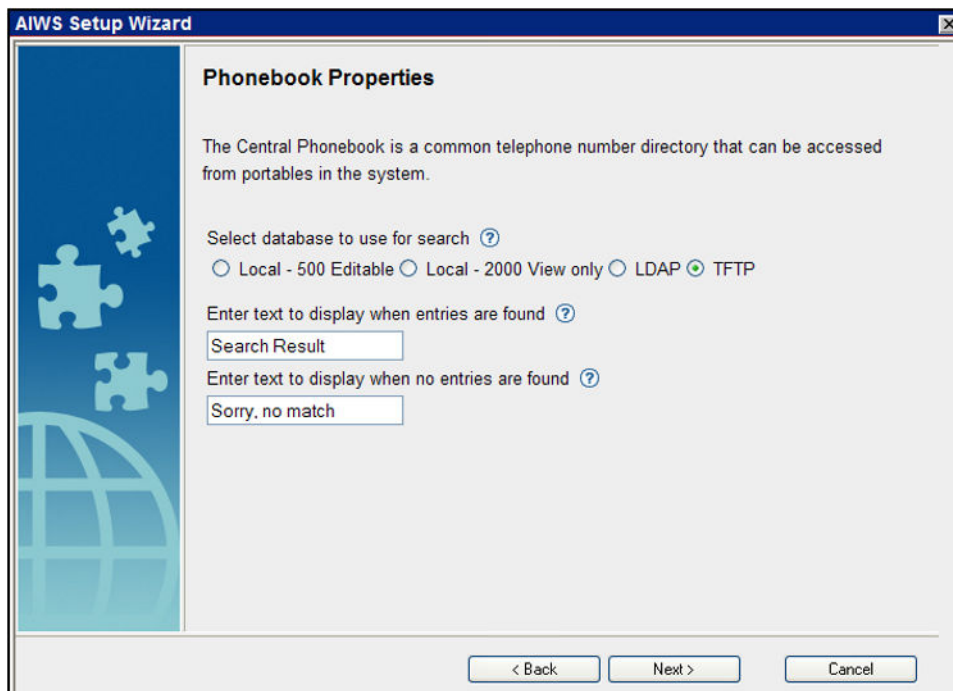

- Set the **TFTP Server IP** to the IP address of the IP Office and click **Next**.

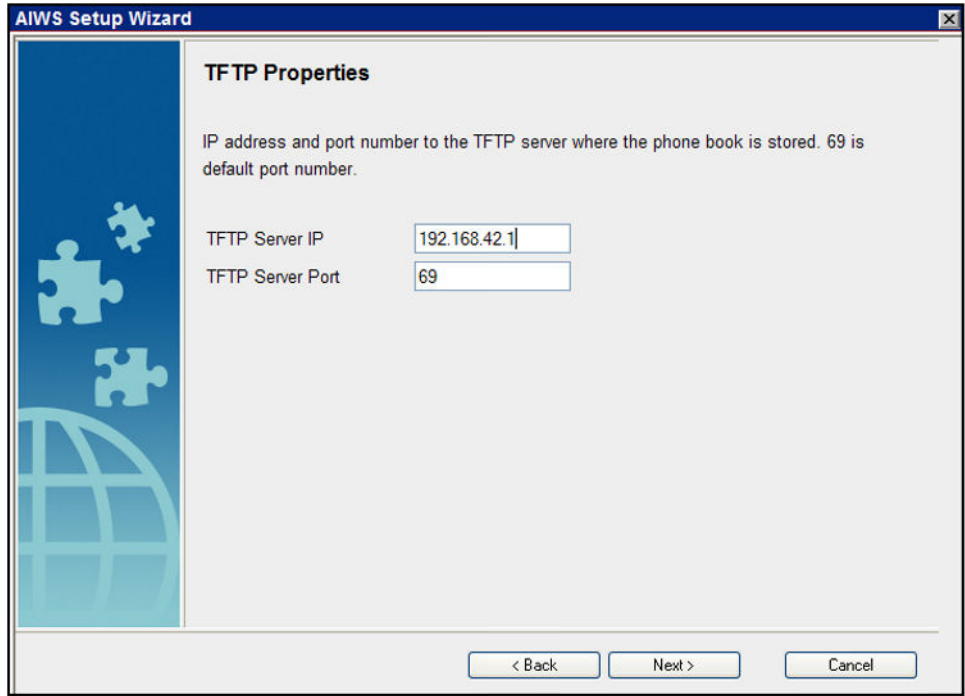

- If necessary, change the default passwords and click **Next**.



- Click **Finish** to save the settings.

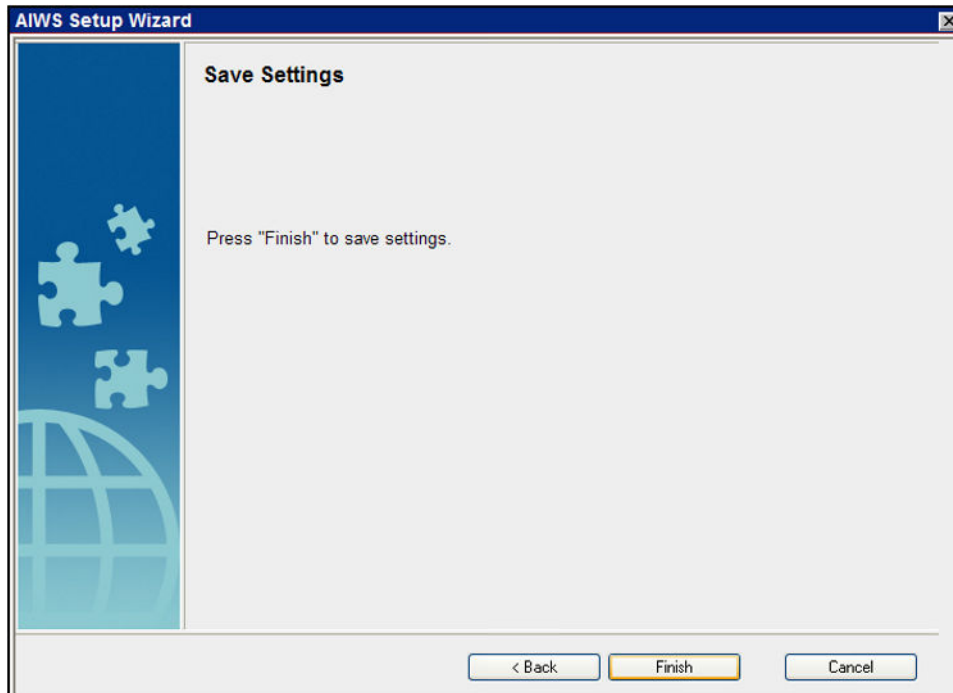

- Click **Restart Now**.

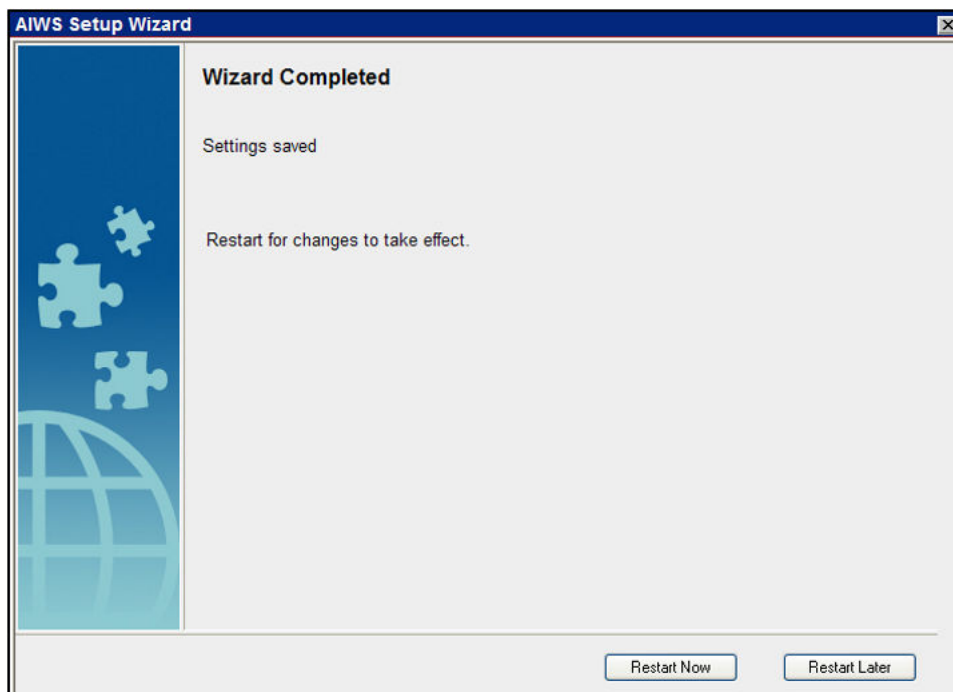

- Close the browser access session. Start a new session using the new IP address.

Enabling Base Station/AIWS Connection

About this task

The IP address of the AIWS needs to be entered into the configuration of the base stations.

Configuring the AIWS DECT Connection (Master Only)

About this task

If the system includes an AIWS, use the following procedure to configure the base station to sync with the AIWS.

If no AIWS is present, proceed to [Phonebook Integration](#) on page 68.

Procedure

1. Select **Services**.
2. Select **Phonebook** and disable the phonebook option.

Configuration	Update	Logging	HTTP	HTTP Client	SNMP	Provisioning	Phonebook	Logout
General								
LAN								
IP								
LDAP								
DECT								
VoIP								
Unite								
Services								
Administration								
Users								
Device Overview								
DECT Sync								
Traffic								

Enable

General Settings

Search Direction Numbers

Phonebook Number

TFTP Settings

Server IP Address

External Directory File

Internal Directory File

Synch. Interval [min]

3. Click **OK**.
4. Select **UNITE**.
5. Select the **Device Management** tab.

Configuration	SMS	Device Management	Service Discovery	Status Log	Logout
General	<div style="border: 1px solid gray; padding: 5px;"> <div style="border: 1px solid gray; padding: 5px;"> <div style="text-align: right; font-weight: bold;">Active Settings</div> IP Address <input type="text" value="0.0.0.0"/> </div> <div style="border: 1px solid gray; padding: 5px; margin-top: 5px;"> <div style="text-align: right; font-weight: bold;">Active Settings</div> Unite IP Address <input type="text"/> Unite Resource Identity <input type="text" value="IPDECT"/> Unite Address <input type="text"/> </div> <div style="margin-top: 5px;"> <input type="button" value="OK"/> <input type="button" value="Cancel"/> </div> </div>				

6. For the **Unite IP Address**, enter the IP address that will be assigned to the AIWS unit when installed in the DECT system.
7. Click **OK** and reset the master base station.

Enabling Status Log (Master and Slave)

Procedure

1. In the left-hand panel, select **UNITE**. Select the **Status Log** tab.

Configuration	SMS	Device Management	Service Discovery	Status Log	Logout
General	<div style="border: 1px solid gray; padding: 5px;"> Unite IP Address <input type="text"/> Unite Resource Identity <input type="text"/> <input type="button" value="OK"/> <input type="button" value="Cancel"/> </div>				
LAN					
IP					
LDAP					
DECT					
VoIP					
Unite					
Services					
Administration					
Users					
Device Overview					
DECT Sync					

2. For the **Unite IP Address**, enter the IP address that will be assigned to the AIWS unit when installed in the DECT system.
3. For the **Unite Resource Identity** enter a unique name to be associated with the base station.
4. Click **OK**.
5. Select the **SMS** tab. Again enter the IP address that will be assigned to the AIWS unit when installed in the DECT system.
6. Click **OK**.

Upgrading the AIWS Firmware

About this task

The AIWS is supplied with a default set of firmware. This must be upgraded to the firmware version provided with the IP Office application software. Only the firmware supplied with the IP Office application software or indicated in IP Office Technical Bulletin should be used with AIWS units on IP Office DECT R4 systems.

- **Important:** This process can take up to 40 minutes.

Procedure

1. Using a browser login to the unit.
2. Click on **Configuration**.



3. Note the software version. Check whether this already matches the firmware detailed as supported by the level of software on the IP Office system.
4. In the browser address bar, change the `/config/start.php` part of the address to `/system`.
5. Click the **Software** button.

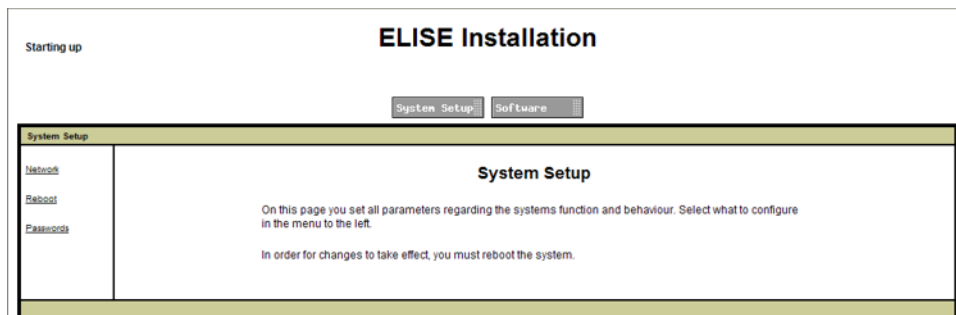

6. In the sidebar, click **Install Image**.

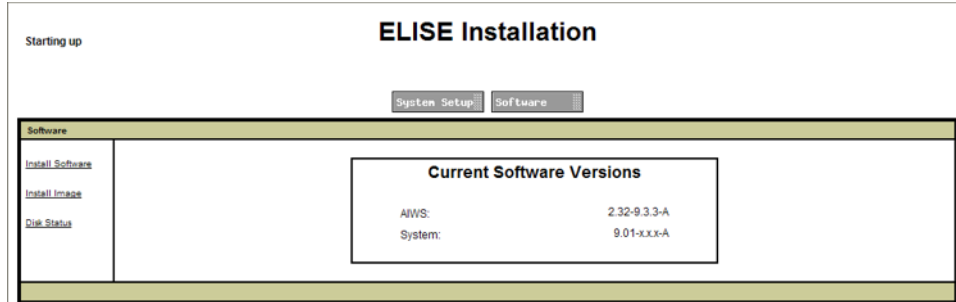

- Click the **Backup parameters** button

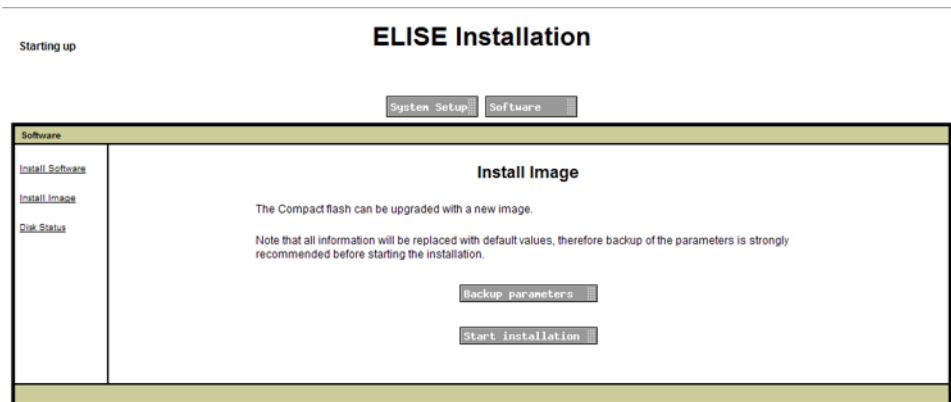

The browser shows a dialog for downloading a file called aiws-backup from the AIWS unit.

- Select the option to save the file and select a save location. Make note of the location as the file needs to be reloaded after the firmware upgrade.
- Click the **Start installation** button. A status and progress window appears:

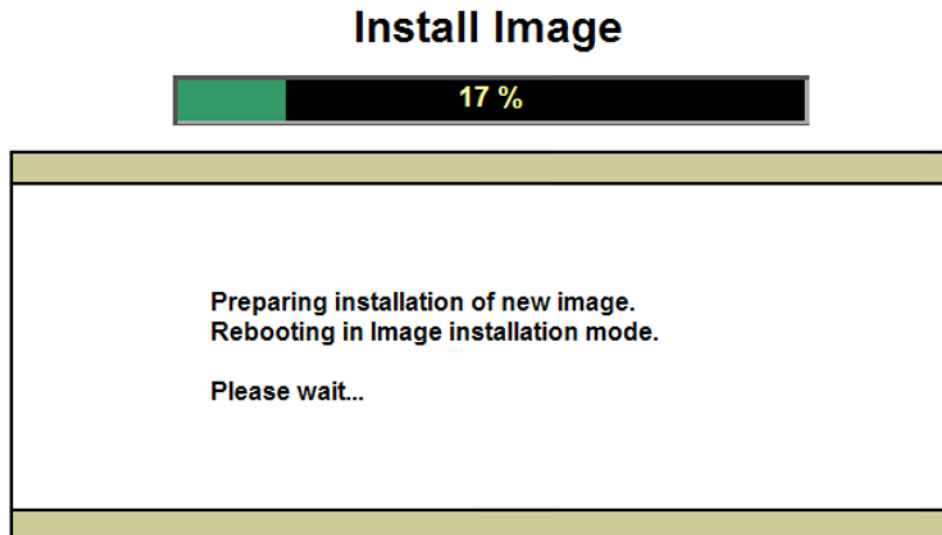

10. After a short delay, the AIWS prompts you for the location of the firmware file for the upload.

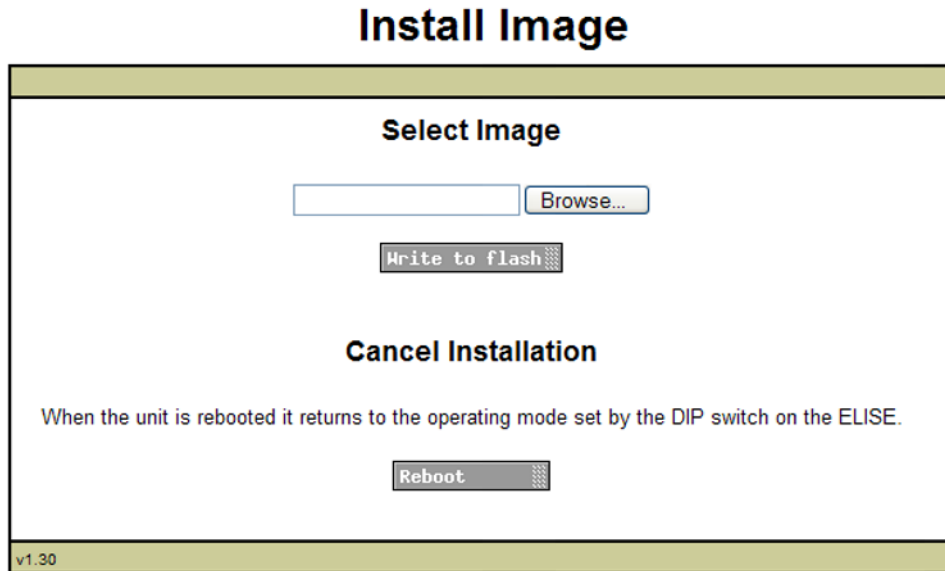

11. Click on **Browse**. Locate the AIWS folder in the software set previously unpacked. Select the .img file.

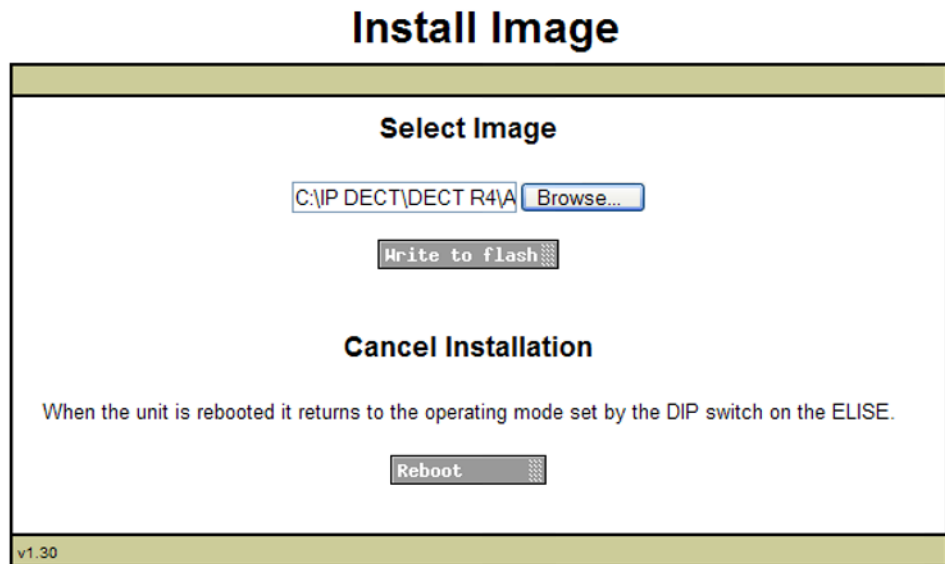

12. Click the **Write to flash** button.

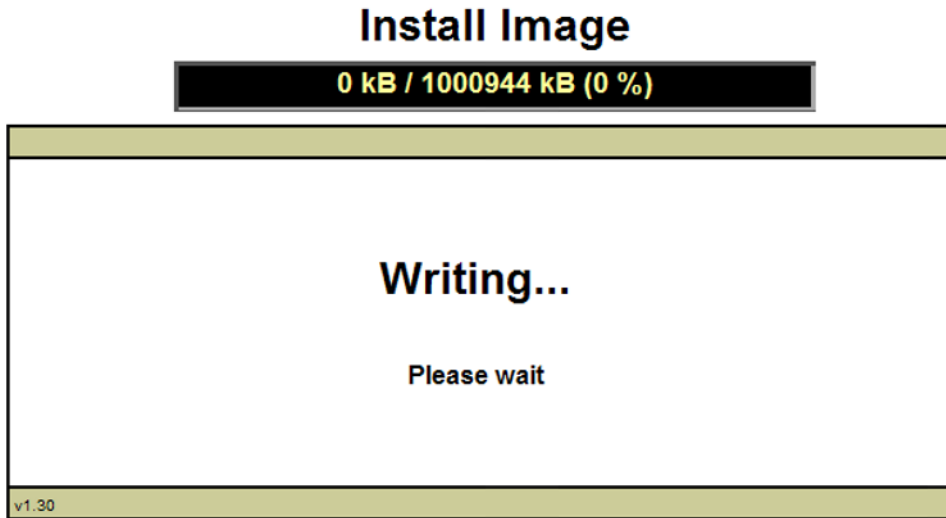

13. Wait for the process to finalize. The process can be time consuming, but must be allowed to complete.

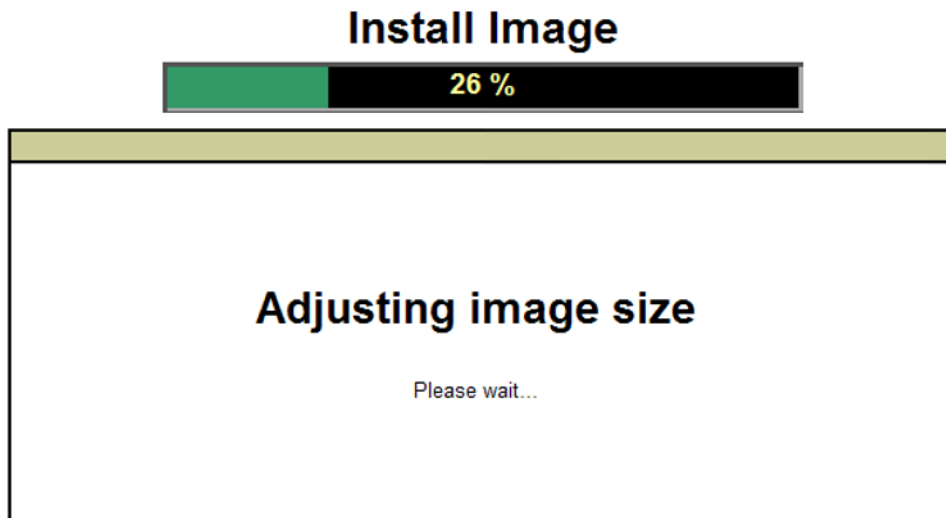

14. If the browser security warning is displayed, select to continue.

Install Image

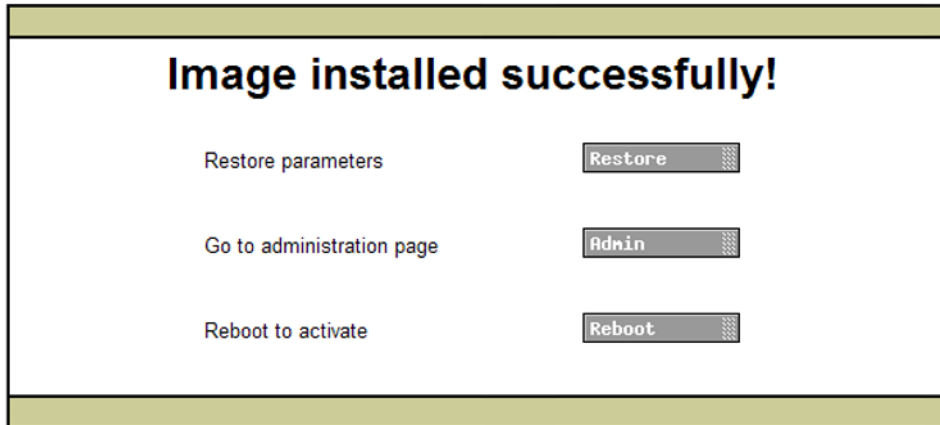

15. Click **Restore**. A separate window opens.
16. Select **Browse**, then locate and select the previously backed up aiws-backup file.

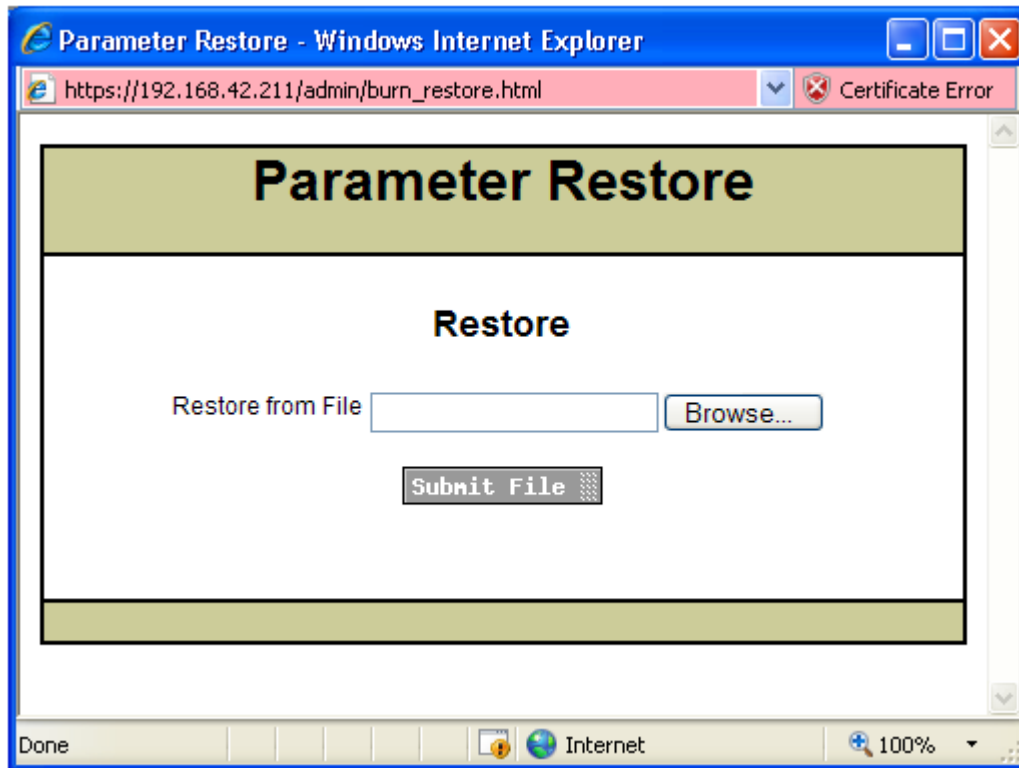

17. Click **Submit file**.

Parameter Restore

Restore

Restore from File

After the parameters are restored, a notification appears.

18. Click **Close**.

Parameters restored!

All parameters except network will take effect immediately.
For network parameters to take effect, the module needs to be restarted

19. Select **Reboot**.

Install Image

Image installed successfully!

Restore parameters	<input type="button" value="Restore"/>
Go to administration page	<input type="button" value="Admin"/>
Reboot to activate	<input type="button" value="Reboot"/>

Switching Off the AIWS

About this task

Having now configured and upgraded the AIWS, it should be switched off and disconnected prior to being wall mounted

Procedure

1. At the top right of the AIWS circuit board, locate the SW4 push button.
2. Press the button until the AIWS lamp starts to flash orange.
3. Remove the power cable. The power must be removed within ten minutes or the AIWS will restart. If the AIWS restarts, wait until the Function Indicator is not indicating starting up (flashing orange) before pressing the SW4 button again.

Mounting the AIWS on a Wall

The AIWS can be wall mounted. To facilitate service after the unit is installed, we recommend a free space of about 150 mm above and 50 mm below the unit.

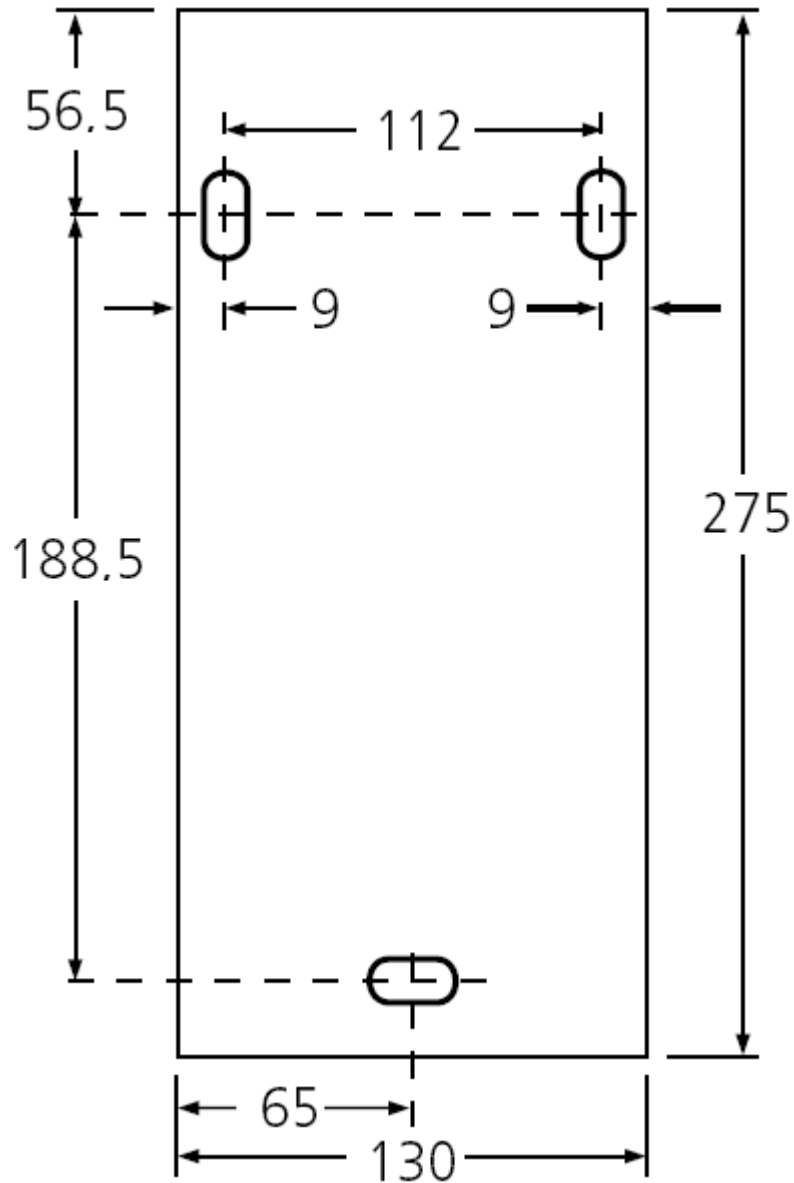

Replacing the AIWS Cover

About this task

The AIWS cover can be clipped back into place without using any tools.

Procedure

1. Check that the AIWS is fully operating (green lamp) and can be browsed from the network.
2. Check that the cables are routed such that they will not be trapped when the cover is replaced.

- Engage the cover with the top edge of the AIWS. Pivot the cover back into position, checking that the various plastic edges are in their original positions.

The cover clips will spring into position.

Installing an AIWS2

Browsing to the AIWS2

By default the AIWS2 will obtain an IP address for the LAN 1 port using DHCP if possible. Using the unit's LAN 1 MAC address, printed on the back of the unit.

Using the Network Connection

Procedure

- Connect the AIWS2 unit to the LAN using the LAN 1 port on the rear of the unit.
- Connect the appropriate power cable to the unit and switch on the power supply.
- The Status LED should change to a fast flashing blue while the unit is starting up.
- When the starting up indication stops, you can attempt to browse to the unit.
- Enter the IP address of the AIWS into the browser address field.
 - Alternatively enter `http://elise-XXXXXXXX` as the address, where **XXXXXXXX** is the module key number printed on the back of the unit. Leading zeros can be omitted.
 - If a security certificate warning appears, select to continue.
 - Enter a user name and password. The default values are **admin** and **changeme**.
 - If this is the first time the AIWS2 has been started, the setup wizard is displayed. Otherwise the AIWS menu is shown.

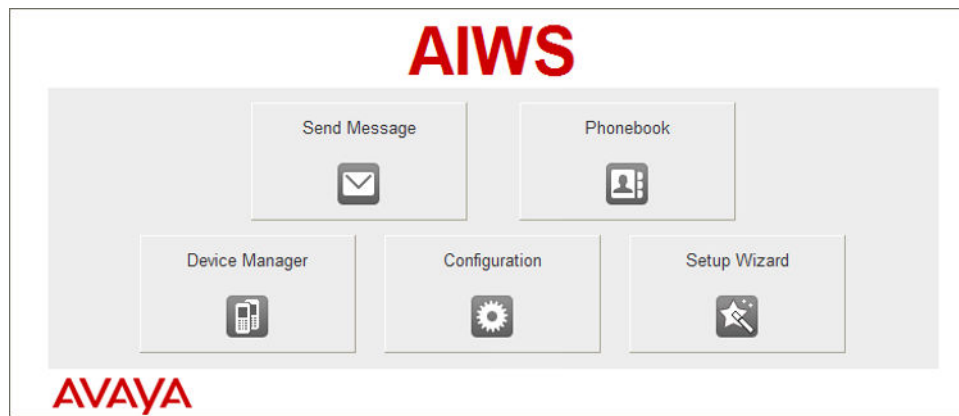

Using the USB Management Connection

The AIWS2 supports connection and administration via a USB cable connected to the **Management** port on the front of the unit. This requires the installation of a device driver that can be obtained from the unit by putting it into its **Mass Storage** mode. Full details for installation and use are provided in the documentation provided with the unit.

Running the Setup Wizard

About this task

The first time the AIWS is accessed it runs the setup wizard.

Procedure

1. Access the AIWS using your browser.
2. If the unit is defaulted, the setup wizard runs automatically. If the unit already has configuration settings, then from the menu displayed select **Setup Wizard**.

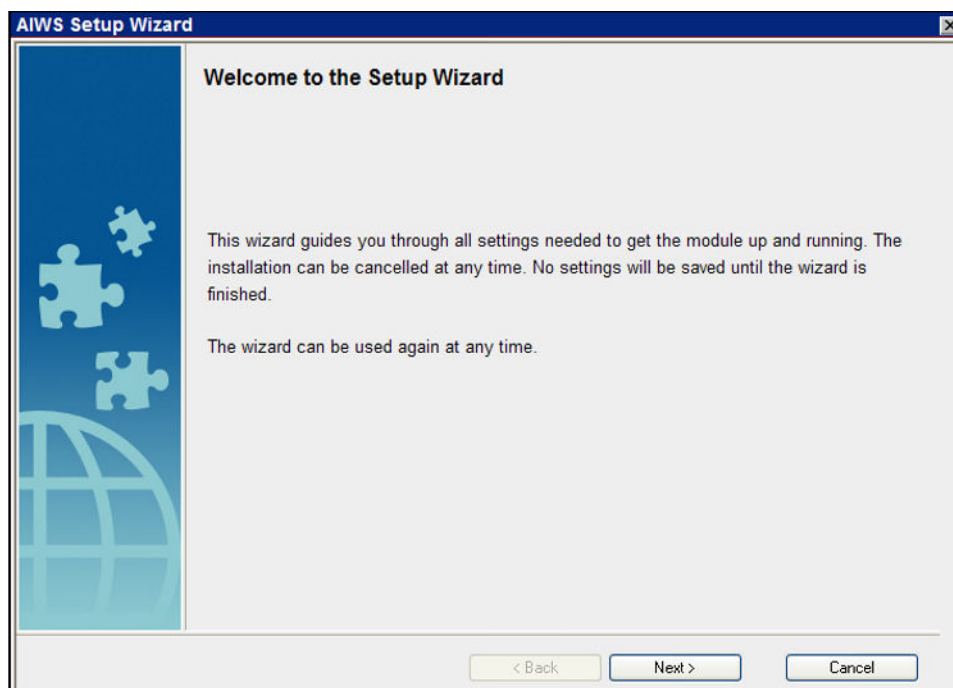

3. Click **Next**.
4. Enter the network address settings for the AIWS unit.

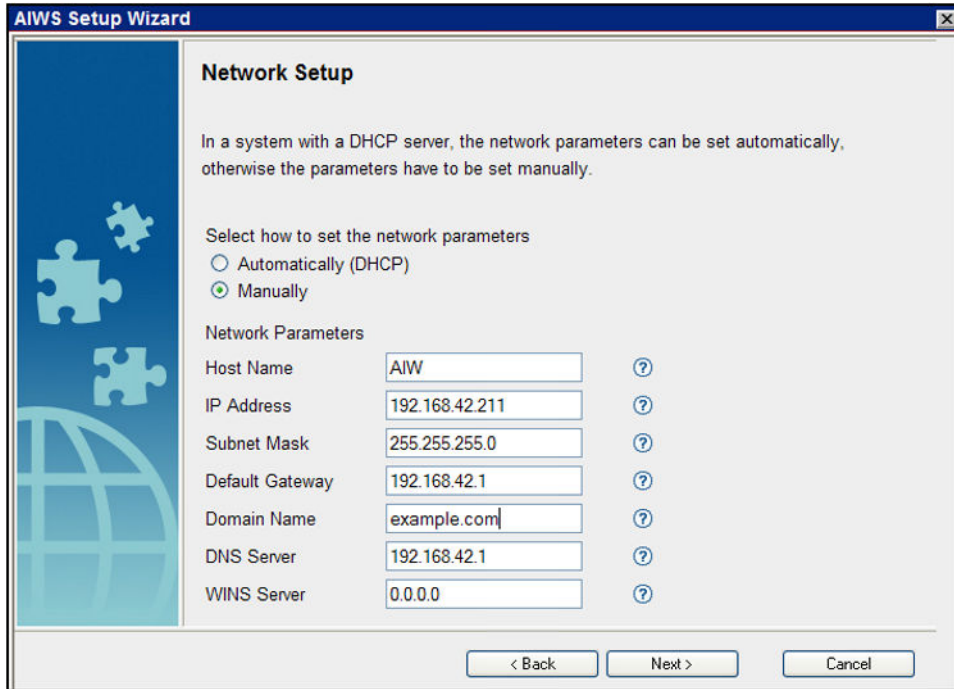

- Set the network parameters mode to **Manually**.
- **Host Name**
Enter a name to help identify the AIWS on the network.
- **IP Address/Subnet Mask**
Enter the static IP address details that the AIWS should use.
- Set the remaining details to match those being used by other devices on the network.
- Click **Next**.
- Enter the license number supplied with the AIWS unit and click **Next**.

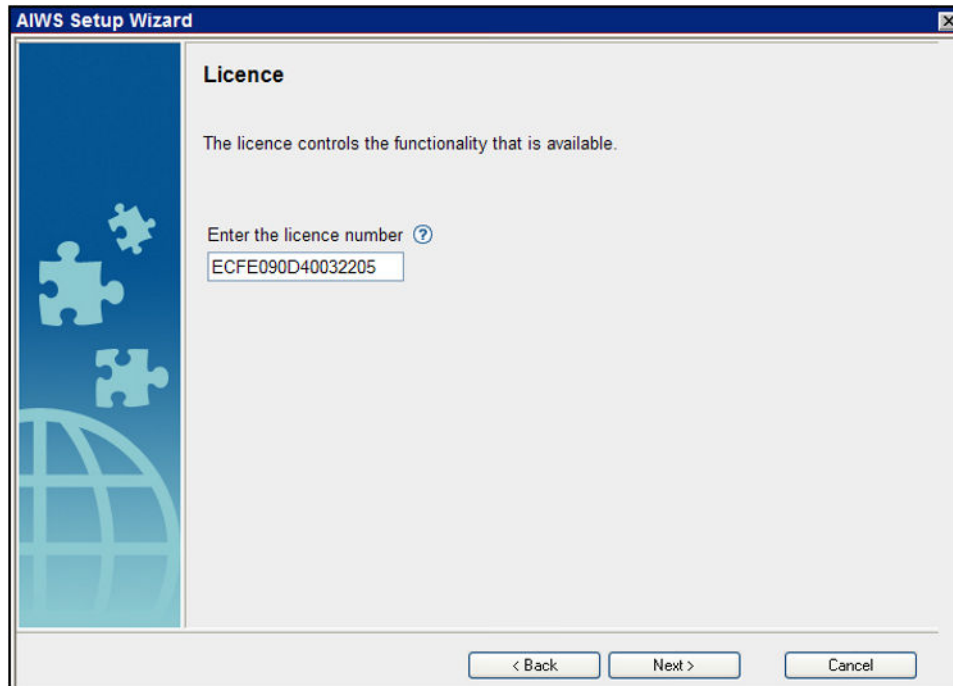

- Enter the IP address of the master base station and click **Next**.

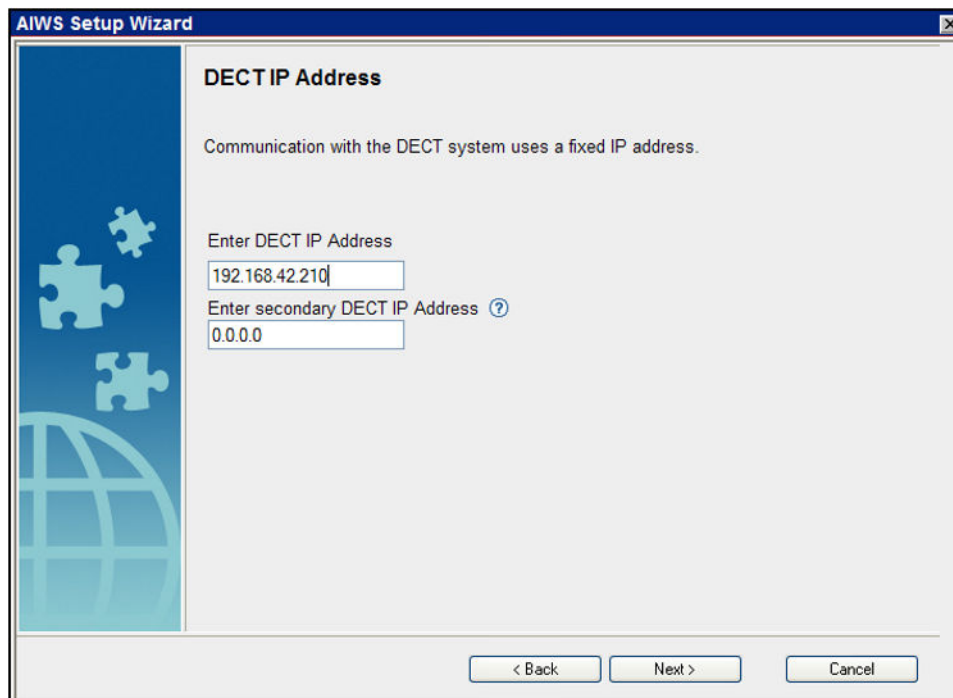

- The **Date and Time** options are displayed. Select **NTP Time Server** and set the **Time Server IP Address** to be the IP address of the IP Office. Adjust the other values to match the customer site.

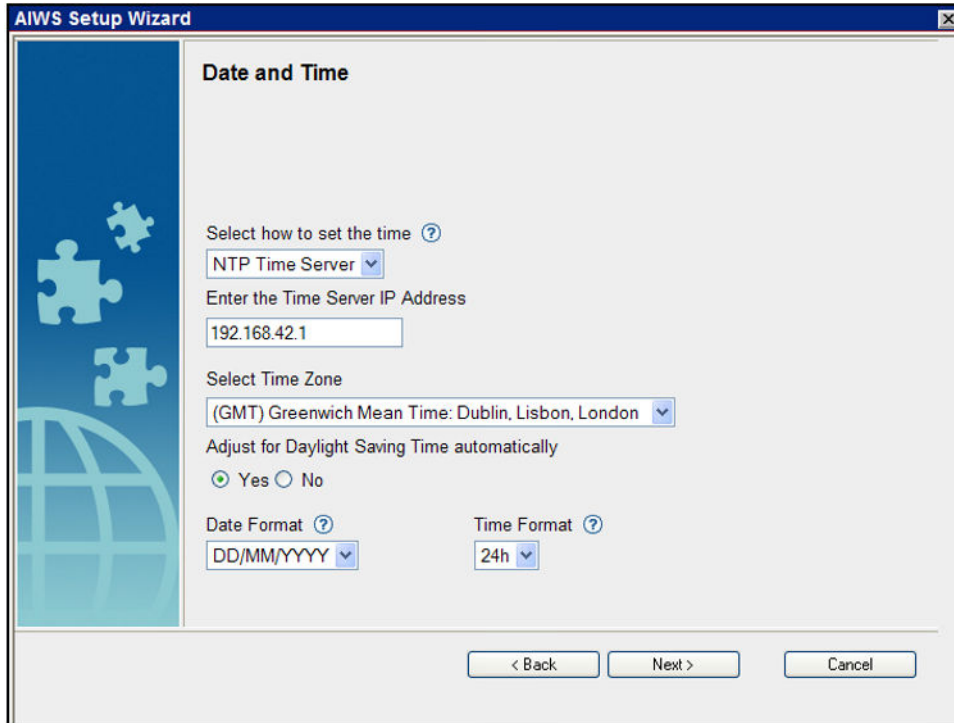

- Click **Next**. The **Phonebook Properties** options are displayed.
- Select **TFTP**, in order to have the AIWS obtain the phone book from the IP Office, and then click **Next**.

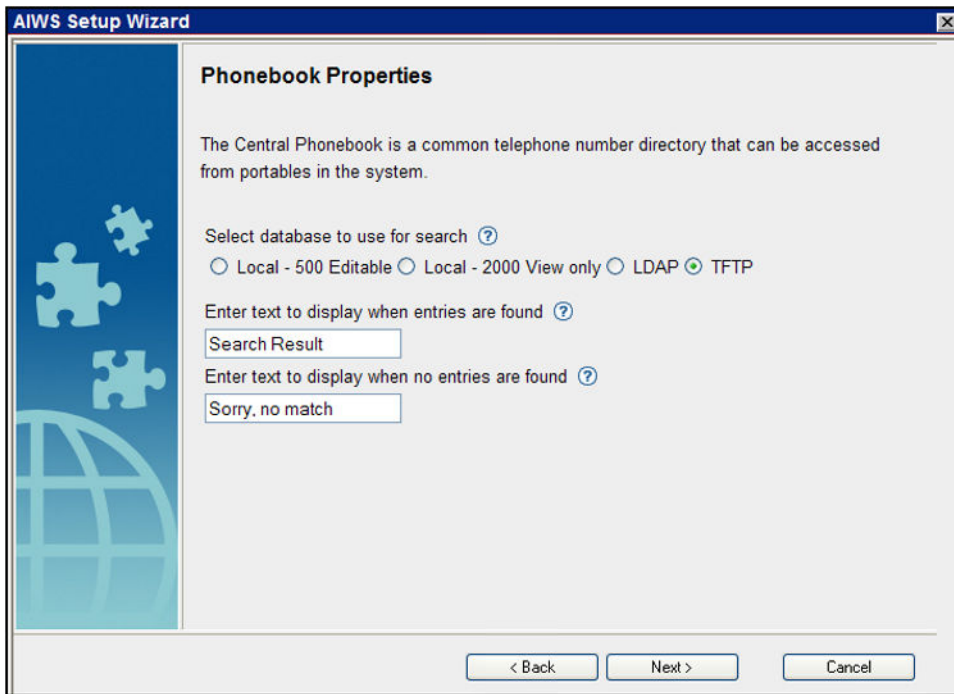

- Set the **TFTP Server IP** to the IP address of the IP Office and click **Next**.

AIWS Setup Wizard

TFTP Properties

IP address and port number to the TFTP server where the phone book is stored. 69 is default port number.

TFTP Server IP:

TFTP Server Port:

< Back Next > Cancel

- If necessary, change the default passwords and click **Next**.

AIWS Setup Wizard

Change Passwords

It is recommended to change default passwords. Leave text fields empty to keep current passwords.

Enter password for sysadmin:

Change Password for: [?](#)

sysadmin	?	<input type="text"/>	Verify Password	<input type="text"/>
admin	?	<input type="text"/>	Verify Password	<input type="text"/>
user	?	<input type="text"/>	Verify Password	<input type="text"/>
ftpuser	?	<input type="text"/>	Verify Password	<input type="text"/>

< Back Next > Cancel

- Click **Finish** to save the settings.

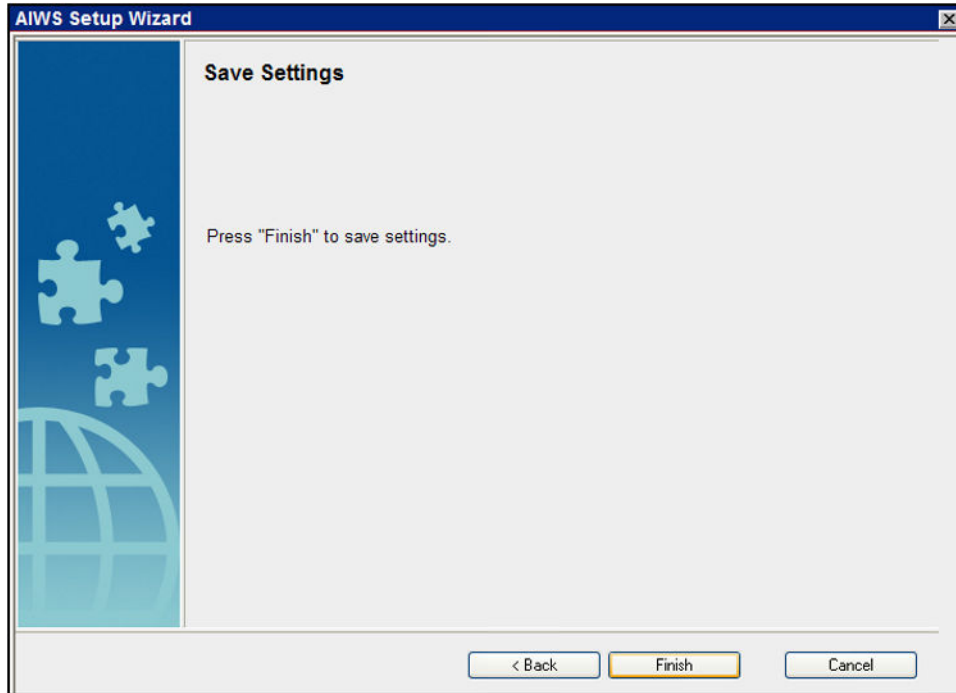

- Click **Restart Now**.

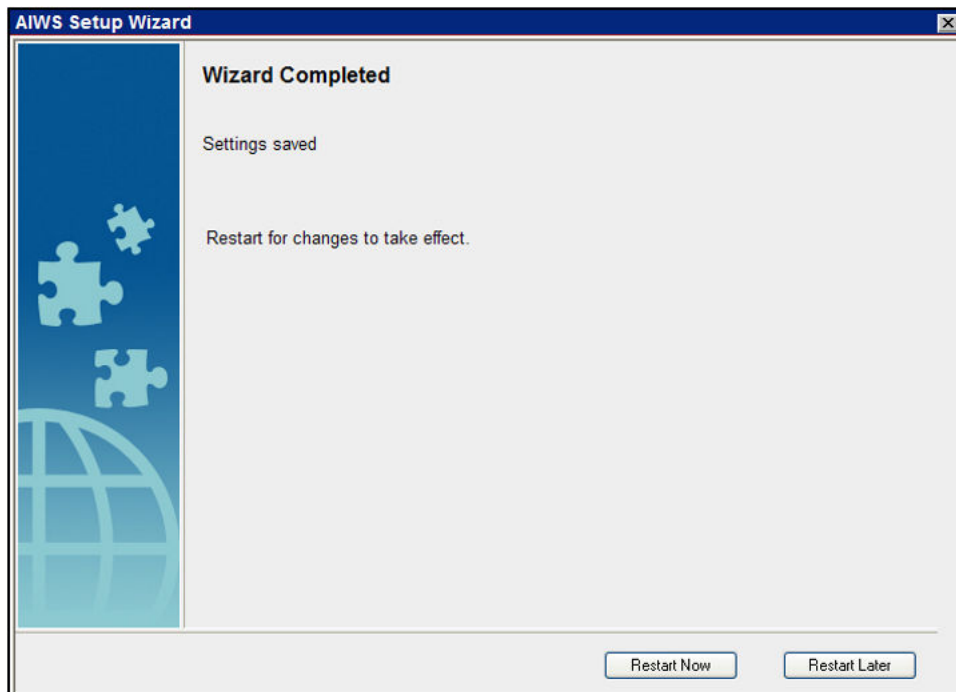

- Close the browser access session. Start a new session using the new IP address.

Enabling Base Station/AIWS Connection

The IP address of the AIWS needs to be entered into the configuration of the base stations.

Configuring the AIWS DECT Connection (Master Only)

About this task

If the system includes an AIWS, use the following procedure to configure the base station to sync with the AIWS.

If no AIWS is present, proceed to [Phonebook Integration](#) on page 68.

Procedure

1. Select **Services**.
2. Select **Phonebook** and disable the phonebook option.

Configuration	Update	Logging	HTTP	HTTP Client	SNMP	Provisioning	Phonebook	Logout
General								
LAN								
IP								
LDAP								
DECT								
VoIP								
Unite								
Services								
Administration								
Users								
Device Overview								
DECT Sync								
Traffic								

Enable

General Settings

Search Direction Numbers

Phonebook Number

TFTP Settings

Server IP Address

External Directory File

Internal Directory File

Synch. Interval [min]

3. Click **OK**.
4. Select **UNITE**.
5. Select the **Device Management** tab.

The screenshot shows a configuration window with a sidebar on the left containing the following menu items: Configuration, SMS, Device Management, Service Discovery, Status Log, and Logout. Under 'Configuration', there is a sub-menu with: General, LAN, IP, LDAP, DECT, VoIP, Unite (highlighted), Services, Administration, Users, Device Overview, and DECT Sync. The main content area is titled 'Active Settings' and contains two sections: 'Portable Devices' with an 'IP Address' field set to '0.0.0.0', and 'IP-DECT Devices' with 'Unite IP Address' (empty), 'Unite Resource Identity' (set to 'IPDECT'), and 'Unite Address' (empty). 'OK' and 'Cancel' buttons are at the bottom.

6. For the **Unite IP Address**, enter the IP address that will be assigned to the AIWS unit when installed in the DECT system.
7. Click **OK** and reset the master base station.

Enabling Status Log (Master and Slave) Procedure

1. In the left-hand panel, select **UNITE**. Select the **Status Log** tab.

The screenshot shows the configuration window with the 'Status Log' tab selected in the top navigation bar. The sidebar on the left has 'Unite' highlighted. The main content area contains 'Unite IP Address' (empty) and 'Unite Resource Identity' (empty) fields, with 'OK' and 'Cancel' buttons at the bottom.

2. For the **Unite IP Address**, enter the IP address that will be assigned to the AIWS unit when installed in the DECT system.
3. For the **Unite Resource Identity** enter a unique name to be associated with the base station.
4. Click **OK**.
5. Select the **SMS** tab. Again enter the IP address that will be assigned to the AIWS unit when installed in the DECT system.
6. Click **OK**.

Upgrading the AIWS Firmware

About this task

The AIWS is supplied with a default set of firmware. This must be upgraded to the firmware version provided with the IP Office application software. Only the firmware supplied with the IP Office application software or indicated in IP Office Technical Bulletin should be used with AIWS units on IP Office DECT R4 systems.

By using a USB memory stick with a Boot software (autoupdate.bin), the module can be upgraded on the field.

Procedure

1. Insert the USB memory stick in the upper USB connector marked 1.
2. Perform a controlled restart via the Restart button, by pressing the button and releasing it within 4 seconds.

The Status LED indicates shutting down with quick flashing blue light. Before starting up again, the Status LED will indicate “waiting” for one minute with flashing yellow light.

3. When the Status LED indicates starting up with quick flashing blue light, press the Mode button within 3 seconds.

The Mode button should indicate boot mode by showing fixed blue light.

Result

The module now detects the memory stick and begins the upgrade process which is indicated by the Status LED with fixed yellow light. The upgrading process takes approximately 7-8 minutes.

After the upgrade process has finished, the module will continue and start up the last used application software. The complete operation may take up to 10 minutes.

To verify a successful upgrade, you can put the USB stick back in your PC and open the file autoupdate.log. In the end of that file, you should see the text “Upgrade finished successfully”.

Note:

If the USB memory stick contains faulty Boot software, the module will start up in Boot Mode.

Upgrading the AIWS2 Software

About this task

Ensure that no Device Manager client is open and that no ftp client is logged in to the module.

The information stored in the database will not be overwritten when new software is installed. Files in the netpage folder in the ftp area that are new or changed are kept when updating.

Procedure

1. Click **Configuration** on the start page.
2. Select **Software > Installation** in the menu on the Configuration page.

*** Note:**

Avaya recommends always performing a backup before installing the new software.

3. Select software (.pkg) to upload. The software will replace the non running software.
4. Select **Switch immediately** if you want to run the new software.
5. Select **Copy current settings** if you want the new software to inherit the settings currently used.

This selection will have no effect if the software type is different than the currently used software. The module will always start up using factory settings if the software type differs.

6. Click the **Start Installation** button.

Switching Software

About this task

If two software versions are installed on the module you can switch between them.

Procedure

1. Click **Configuration** on the start page.
2. Select **Software > Switch** in the menu on the Configuration page.
3. Under **Select settings**, select one of the following:
 - Keep previous settings — means that the settings last used for the software is activated again after the switch. This option is only available if the software has been used at least one time before.
 - Copy Current settings — means that you copy the configuration from the software you are currently using and is only available if both software are of the same type.
 - Use factory default settings — means that you apply the default settings that were delivered from the factory.

*** Note:**

The active software current network settings will be kept and will also be applied to the software you want to switch to.

4. Click **Switch**.

Chapter 9: Non-Provisioned Installation

This method of installation is used with pre-IP Office Release 7.0 systems and systems that include handsets that do not support IP Office provisioning.

- **When to Use Non-Provisioned Installation**

The use of IP Office [Provisioned Installation](#) on page 42 is recommended for all installations except those that do not contain 3700 Series phones.

- It is assumed that you are familiar with installation and configuration of IP Office systems.

The installation process and screen captures used in this document are for example only. Other methods and order of installed devices can be used once you become familiar with the installation process. For example, installing all of the slave base stations before installing the master base station.

A Non-Provisioned installation consists of the following procedures:

- [Unpacking the DECT Software](#) on page 168
- [Configuring IP DECT Lines](#) on page 169
- [Adding Licenses](#) on page 170
- [Configuring the Master Base Station](#) on page 171
- [Configuring IP Slave Base Stations](#) on page 191
- [Mounting the Base Stations](#) on page 201
- [Subscribing DECT Phones](#) on page 203

IP Office Installation Requirements

- It is assumed that you are familiar with installation and configuration of IP Office systems.

Information

- Service user name and password for IP Office configuration access.
- Service user name and password for IP Office security settings access.
- IP Office IP address.
- Avaya IP Endpoint licenses.

Parts Required

- IP Office Release 10.1 software DVD or image of the IP Office Release 10.1 admin software.

Tools Required

- Programming PC with IP Office Manager application installed. You must have administrator rights on this PC to change its IP address settings unless it is functioning as a DHCP client.
- Software for zip file extraction.

IP Base Station Installation Requirements

Information

- DECT R4 SARI.
- Base Station IP Addresses.
- Detailed plans from the site survey indicating the intended base station locations, LAN sockets and if necessary power supply outlets.

Parts Required

- Base station

Includes:

- Base station.
- Two 3.5mm screws and two 6mm wall plugs suitable for wall mounting onto a solid wall (brick or similar).
- 1.2 metre (4 foot) LAN cable. If this is replaced with a longer cable the replacement should be a CAT5 Ethernet LAN cable.

 **Important:**

For DECT firmware 10.0 and higher, supported with IP Office Release 10.0 and higher, IPBS1 base stations are only supported as slave radio base stations . IPBS1 base stations are no longer supported in other roles, for example as master base stations. For systems being upgraded, any existing IPBS1 base station being used such other roles must first be replaced in that role with an IPBS2 or IPBL1.

- If using Power over Ethernet:
 - The base station supports Power over Ethernet, IEEE 802.3af, class 2.
- If not using Power over Ethernet:
 - Base station power supply unit.

Required if not using Power over Ethernet to power the base station. Note that the base station power supply units include an 8 metre (26 feet) cable from the PSU to the base station. Check that you have the correct type of power supply unit for the locale.

 - BSX-0013: Europe (except United Kingdom).
 - BSX-0014: United Kingdom.
 - BSX-0015: USA/Canada.
 - BSX-0016: Australia.
 - Mains power outlet socket.
- LAN Socket.

Tools

- Programming PC with DECT R4 software.
- Web browser.
- Drill and drill bits suitable for the selected wall mounting position of the IPBS.
- Screwdrivers for use with the screws selected for IPBS wall mounting.

Phone Subscription Requirements

Information

- Service user name and password for IP Office configuration.
- User names and extension numbers for the DECT phones.
- Phone IPEI numbers if using pre-configured installation mode.

Tools

- **IP Office Manager.**
- **Device Manager**

The software installed on each handset may need to be upgraded to match that supplied with the DECT R4 software. This is done using the Windows Device Manager software to

upgrade phones via an advanced charger or using AIWS Device Manager to upgrade phones over the air.

- Web browser (Internet Explorer or Firefox are supported).

Unpacking the DECT Software

About this task

Before beginning installation of DECT R4, in addition to having IP Office Manager installed, unpack the DECT R4 software onto your programming PC.

DECT R4 is supported on a range of Avaya systems. However, for IP Office operation, only firmware specifically documented as having been tested and supported with IP Office should be used. Details of supported firmware will be included in IP Office Technical Bulletins and Technical Tips.

Procedure

1. On the programming PC, create a folder with a name indicating its purpose, for example **c:\IP_DECT_R4**.
2. Within the IP Office Administrator Application software (ie. the software from which IP Office Manager is installed), locate the folder **IPDECT**.

The folder contains a file `DECT R4.zip`. This is the file containing software for DECT R4. The file `IPDECT.zip` contains software for the previously supported IP DECT product and not for DECT R4

3. Copy the `DECT R4.zip` file to the folder created on the programming PC.
4. Using WinZip or a similar tool, extract the contents of the zip file into the folder, maintaining the directory structure of the zip files.

The set of files should appear similar to the following.

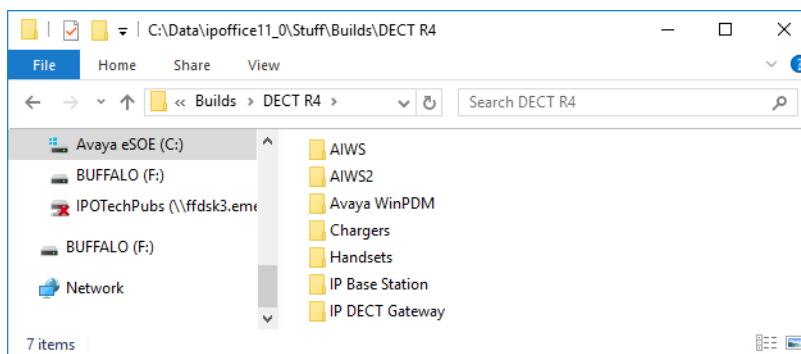

5. Check the software versions as follows:
 - Open the `IP Base Station` folder. There are separate sub-folders for **IPBS1** and **IPBS2** base stations. Open each and note the software level shown as part of the `.bin`

file filenames, there are separate files for the base station boot file and firmware file. All of the base stations in the installed system should run the same version of software.

- Open the `Handsets` folder and note the software level shown as part of the `.pkg` file filenames. The handsets in the system should be running this level of software or higher.
- Open the `IP DECT Gateway` folder and note the software level shown as part of the `.bin` filenames. These versions should be of the same level as the IP Base Stations. The IP DECT Gateway software versioning is in sync with the IP Base Station software versioning.

IP DECT Line Setup

About this task

Use the following procedure to create an IP DECT line for traffic between the IP Office and the DECT R4 system. The line is configured with the IP address that will be assigned to the master base station. The IP Office configuration only requires a single IP DECT line.

* Note:

Adding or removing a line from the IP Office configuration requires the IP Office system to reboot. This will end all calls and services in progress.

Procedure

1. Using IP Office Manager, retrieve the configuration from the IP Office system.
2. Click on **Line**. The list of existing lines is shown.
3. Click on the  icon and select **IP DECT Line**. The settings for an IP DECT line are displayed. If the option is greyed out then the configuration already contains an IP DECT line.
4. On the **Line** tab there are no adjustable settings. Once the system is installed and operational, this tab lists the DECT extensions.

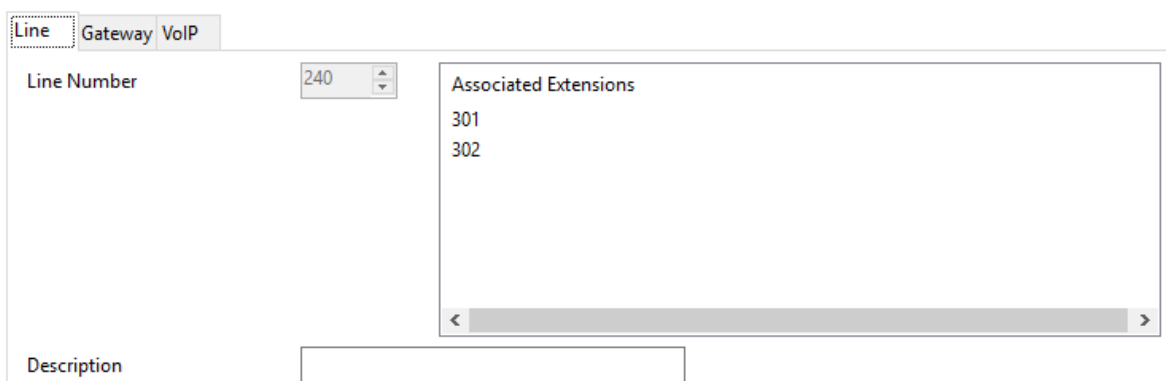

The screenshot shows the configuration window for an IP DECT line. At the top, there are three tabs: 'Line', 'Gateway', and 'VoIP'. The 'Line' tab is active. Below the tabs, there is a 'Line Number' field with a dropdown arrow, currently showing '240'. To the right of this is a list box titled 'Associated Extensions' containing the numbers '301' and '302'. Below the list box is a horizontal scrollbar. At the bottom left, there is a 'Description' label followed by an empty text input field.

5. Select the **VoIP** tab. This table is used to set details of the master base station.

The screenshot shows a configuration window with three tabs: 'Line', 'Gateway', and 'VoIP'. The 'VoIP' tab is active. The 'Gateway IP Address' field is set to '192 . 168 . 0 . 226'. The 'Standby IP Address' field is set to '0 . 0 . 0 . 0'. The 'Codec Selection' dropdown is set to 'Custom'. Below this, there are two lists: 'Unused' and 'Selected'. The 'Unused' list contains 'G.723.1 6K3 MP-MLQ'. The 'Selected' list contains 'G.711 ULAW 64K', 'G.711 ALAW 64K', and 'G.729(a) 8K CS-ACELP'. Between the lists are five buttons: '>>>', '↑', '<<<', '↓', and '>>>'. At the bottom, there are two dropdown menus: 'TDM->IP Gain' set to 'Default' and 'IP->TDM Gain' set to 'Default'. On the right side, there are two checkboxes: 'VoIP Silence Suppression' (unchecked) and 'Allow Direct Media Path' (checked).

6. Set the **Gateway IP Address** to match the IP address that will be assigned to the master base station.
Leave the other fields at their default settings.

Adding Licenses

About this task

Each IP DECT extension requires an Avaya IP Endpoint license. This applies even if the handset subscribed to the IP DECT R4 system is not an Avaya phone.

Phones without a license will still be able to subscribe and register but will be limited to making emergency calls only (calls that match an IP Office **Dial Emergency** short code). The associated user will be treated as if logged off . If a license becomes available, it will be assigned to any unlicensed DECT handsets first and then to any other unlicensed Avaya IP phone in the order that the phones registered.

- **Avaya IP Endpoint Licenses**

Licenses are added to the IP Office configuration and are based on a serial number unique to the system.

- Licenses are normally automatically assigned to extensions in order of registration. However, existing extensions can be configured to reserve a license. This ensures that they do not become unlicensed when newly added extensions manage to register first following a system reboot.

Reserving Licenses

About this task

Licenses are automatically assigned to extensions in order of registration. However existing extensions can reserve a license in order to ensure they do not become unlicensed when new extensions added to the system manage to register first following a system reboot.

Procedure

1. In IP Office Manager, select **Extension** and then select the DECT extension.
2. Select the **IP DECT** tab. Note, the appearance of this menu will vary depending on whether you are doing a provisioned or non-provisioned installation.

3. The **Reserve Avaya IP endpoint license** setting is used to reserve an existing license for the extension. The option is greyed out if the configuration does not have sufficient unreserved licenses remaining.
4. Repeat the process for any other extensions for which you want to reserve the license.
5. Save the configuration back to the IP Office system.

Configuring the Master Base Station

* Note:

If an IP DECT Gateway is being installed, Avaya recommends configuring the IP DECT Gateway as the master base station for the system. For information on installing an IP DECT Gateway, see [IP DECT Gateway Installation](#) on page 105.

The base station installation process consists of the following stages:

1. [Defaulting the Base Station](#) on page 173
2. [Accessing the Base Station Configuration](#) on page 174

3. [Updating the Base Station Firmware](#) on page 175
4. [Setting the Base Station IP Address](#) on page 177
5. [Setting the Time Source](#) on page 180
6. [Configuring QoS/ToS Settings](#) on page 181
7. [Setting the Base Station as Master](#) on page 181
8. [Enabling Supplementary Services](#) on page 183
9. [Selecting the PBX Switch Mode](#) on page 183.
10. [Configuring the IPTrunk](#) on page 184
11. [Entering the Radio Settings](#) on page 185
12. [Entering the PARI](#) on page 186.
13. [Entering the SARI/PARK](#) on page 187
14. [Configuring Air Sync](#) on page 187
15. [Integrating the IP Office Directory](#) on page 189
16. [Resetting the Base Station](#) on page 190
17. [Checking the Base Station Configuration](#) on page 190

Pre-Requisites

- IP Office connected to the LAN with IP DECT line configured for master base station IP address.

Information

- DECT R4 SARI.
- Base Station IP Addresses.
- Detailed plans from the site survey indicating the intended base station locations, LAN sockets and if necessary power supply outlets.

Parts Required

- Base station

Includes:

- Base station.
- Two 3.5mm screws and two 6mm wall plugs suitable for wall mounting onto a solid wall (brick or similar).

- 1.2 metre (4 foot) LAN cable. If this is replaced with a longer cable the replacement should be a CAT5 Ethernet LAN cable.

! **Important:**

For DECT firmware 10.0 and higher, supported with IP Office Release 10.0 and higher, IPBS1 base stations are only supported as slave radio base stations . IPBS1 base stations are no longer supported in other roles, for example as master base stations. For systems being upgraded, any existing IPBS1 base station being used such other roles must first be replaced in that role with an IPBS2 or IPBL1.

- If using Power over Ethernet:
 - The base station supports Power over Ethernet, IEEE 802.3af, class 2.
- If not using Power over Ethernet:
 - Base station power supply unit.

Required if not using Power over Ethernet to power the base station. Note that the base station power supply units include an 8 metre (26 feet) cable from the PSU to the base station. Check that you have the correct type of power supply unit for the locale.

- BSX-0013: Europe (except United Kingdom).
 - BSX-0014: United Kingdom.
 - BSX-0015: USA/Canada.
 - BSX-0016: Australia.
 - Mains power outlet socket.
- LAN Socket.

Tools

- Programming PC with DECT R4 software.
- Web browser.
- Drill and drill bits suitable for the selected wall mounting position of the IPBS.
- Screwdrivers for use with the screws selected for IPBS wall mounting.

Defaulting the Base Station

About this task

This process will default a base station or IP DECT Gateway, erasing its configuration. After the unit restarts it will default to the IP address 192.168.0.1/255.255.255.0.

*** Note:**

The following instructions assume you are installing an IPBS2, which has one LED lamp. The IPBS1 has two LED lamps. For more information on the base station LEDs and what their statuses indicate, see [Base Station Status Lamps](#) on page 14.

Procedure

1. With only the power supply connected, switch the base station on.

The LED on the base station flashes red if no Ethernet is detected.

2. Wait approximately five seconds.

3. Press and hold the **Reset** button on the base station for approximately 10 seconds..

The LED on the base station will change to a quick flash, then the LED will go out, and then the LED returns to a slower flash.

4. Release the Reset button and wait for the base station to reset.

The LED should turn back on to solid amber.

5. Quickly press the **Reset** button once.

The base station reboots with default settings. The default IP is 192.168.0.1, with DHCP on, but not active. If you wish to activate DHCP reset the base station again.

*** Note:**

Avaya recommends disabling the DHCP on the base station and configuring the system with static IP addresses. For information on disabling DHCP on the base station, see [Set the Base Station IP Address](#) on page 57.

Accessing the Base Station Configuration

Procedure

Depending on whether DHCP is being used or not:

- a. Connect the base station to the network or PC using the LAN cable.
- b. If connected directly to the base station, change your programming PC's network address to 192.168.0.200 with subnet mask 255.255.255.0.
- c. If both your PC and the base station are connected to a LAN network with DHCP server, ensure your PC is set to act as a DHCP client or has a fixed address that is valid on the network.
- d. Start your web browser and enter the http:// or https:// followed by the IP address of the base station. The default IP address is 192.168.0.1. If a security certificate warning is displayed, select to continue to this website.
- e. The base station responds with its login menu.



IP-DECT Base Station

Select login

- f. Select **System administration**. Enter the default user name (**admin**) and password (**changeme**) and click **Login**.
- g. A summary of the current logins is displayed. Click **OK**.
- h. The configuration menu for the base station is displayed.

Configuration	Info	Admin	EULA	Logout
General				
LAN	Version IPBS[10.0.5], Bootcode[10.0.5], Hardware[IPBS1-Y4/PD]			
Administration	Serial Number 09AD15300066			
Backup	MAC Address (LAN) 00-01-3e-01-6f-9c			
Update	DRAM 32 MB			
Diagnostics	FLASH 8 MB			
Reset	Coder 8 Channels of G.711,G.729,G.723			
	SNTP Server 192.168.0.214			
	Time **.*.***			
	Uptime 0d 1h 38m 42s			

- i. Note the software levels shown in the **General | Info** menu. These will determine if the base station software needs to be upgraded.

*** Note:**

Compact Base Stations have advanced menu options hidden by default. To enable or disable Advanced Administration menus, see [Select Administration Mode](#) on page 62 .

Updating the Base Station Firmware

About this task

The base station may need to be upgraded to match the software version supplied for use with the IP Office. The base station software consists of two parts, a firmware file and a boot file. All base stations in a DECT system should use the same version of software.

Procedure

1. Browse into the base station configuration and note the software levels shown by the **Version** line.

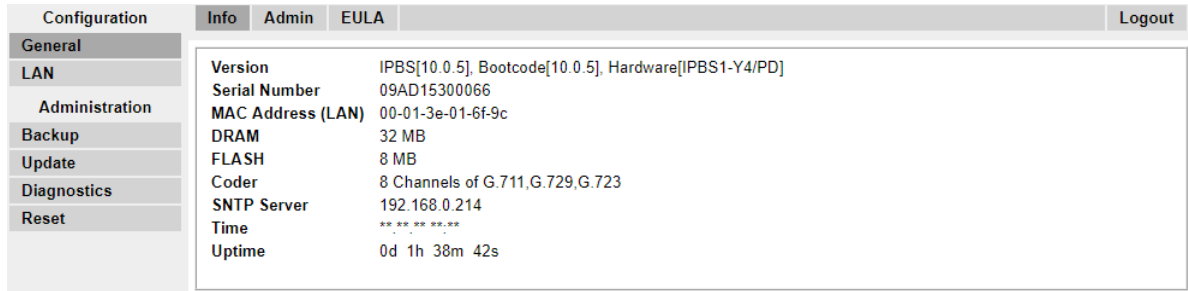

2. Check that these match the versions supplied with the IP Office administration software.

Ensure that you are checking against the correct folder for an IPBS1 or IPBS2 base station. If they do not match, you must upgrade the base station.

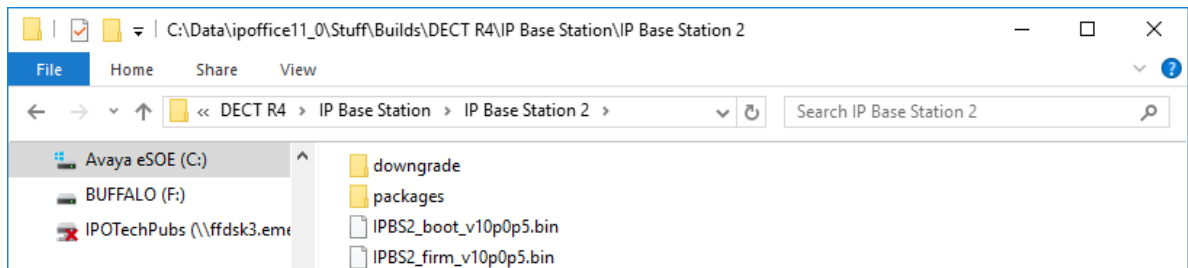

If both software files need to be upgraded, the boot file should be upgraded first.

3. In the left-hand column, under the **Administration** menu, select **Update** and then select the **Boot** tab.

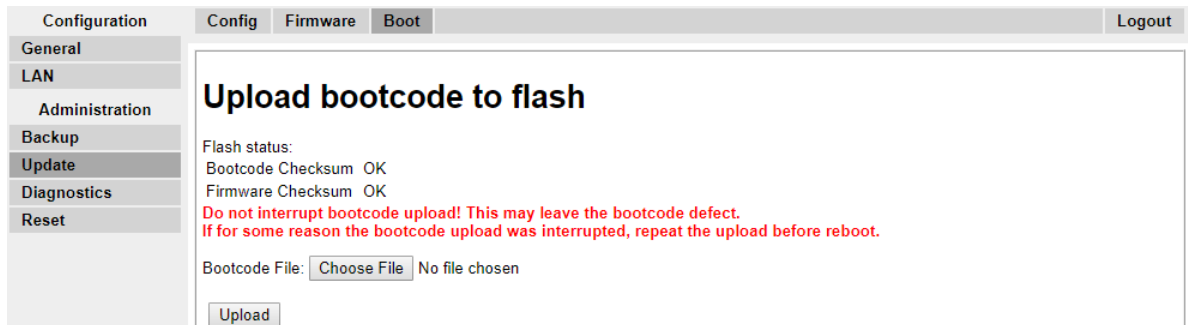

4. Click on the **Browse** button and browse to the **IP Base Station 2** sub-folder of the IP DECT R4 software.
5. Select the appropriate boot file for the upgrade you are performing.
6. Click **OK**.
7. Click on the **Upload** button.

The browser shows the progress of the upload and upgrade. It will indicate when the process has been completed.



8. If necessary, repeat the process to upgrade remaining base stations.
9. To upgrade the base station firmware file, select **Update** and then select the **Firmware** tab.

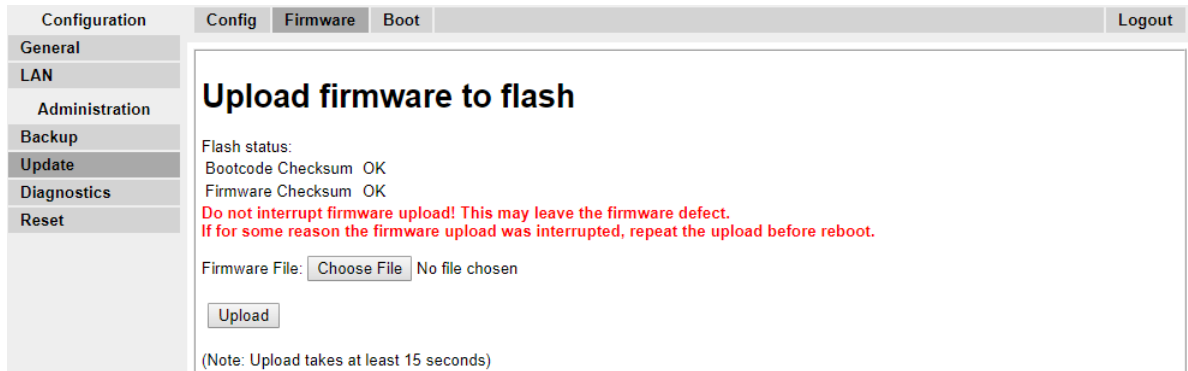

10. Click on the **Browse** button and browse to the **IP Base Station** sub-folder of the IP DECT R4 software you previously extracted onto the programming PC.
11. Select the appropriate firmware file for the upgrade you are performing,
12. Click **OK**.
13. Click on the **Upload** button.

The browser shows the progress of the upload and upgrade. It will indicate when the process has been completed.

14. Click on **Reset**.
15. Log in again. The **General | Info** tab should now list the new firmware.

If necessary, repeat the process for the remaining base stations using the **Update | Firmware** menu.

If necessary, update the base station firmware for base stations that will be connected to an IP DECT Gateway using the **Update | RFPs** menu.

Setting the Base Station IP Address

About this task

During initial installation the IP address of a base station defaults to 192.168.0.1. The process below can be used to change the DHCP mode and IP address of a base station.

Procedure

1. From the base station configuration window, in the left-hand column, select **LAN**.

2. Select the **IP** tab.

- a. Enter the required **IP Address** and **Network Mask** for the base station. The other settings are optional.
- b. Click **OK**.

*** Note:**

The menu will prompt you with the message **Reset Required**. Do not click this or reset the base station at this stage.

- c. Select the **DHCP** tab.

- d. Using the **Mode** drop-down, select **Disabled**.
- e. Click **OK**.
- f. Select **Reset** and then select the **Reset** tab.
- g. Click **OK**.
- h. Depending on your base station, wait for the LED to return to solid blue or solid green.
- i. Log in again using the new IP address.

Configuring a Virtual Local Area Network (VLAN)

Both IPBS1 and IPBS2 support VLAN capability. Note that the VLAN ID must be the same as the ID configured in the IPBS/IPBL, otherwise access to the IPBS/IPBL will not be possible.

Note: If "VLAN = 0", the Quality of Service (QoS) is inactive according to 802.1q. You should also avoid "VLAN = 1" as it is often used as a default VLAN setting.

Configuring a VLAN

About this task

Use the following procedure to configure a VLAN ID on a systems comprised of switches and endpoints that support VLAN tagging (IEEE 802.1q).

Procedure

1. Under the **Configuration** menu, navigate to **LAN** and then select the **VLAN** tab.

2. In the **ID** field, enter the parameter configured in the IPBS/IPBL.
3. Click **OK**.

Viewing LAN Statistics

About this task

To view statistics of LAN events:

- On the IPBS, select **LAN > Statistics**.
- On the IPBL, select **LAN1 > Statistics**.

Press **Clear** to reset the ethernet statistics counters. You may need to scroll down to view the **Clear** button.

Deactivating LAN Port (IPBL only)

About this task

The IP DECT Gateway (IPBL) has two LAN ports. The LAN2 port is used for administration only. If necessary, you can deactivate that port.

Procedure

1. Select **LAN2 > IP**.

Note: The LAN2 port is for administration only. It is typically the port you want to deactivate.

Configuration	System	Suppl. Serv.	Master	Trunks	Radio	Radio config	PARI	SARI	Air Sync	Logout
General										
LAN										
IP										
LDAP										
DECT										
VoIP										
Unite										
Services										
Administration										
Users										
Device Overview										
DECT Sync										
Traffic										

Active Settings

IP Address 192.168.1.1

Network Mask 255.255.255.0

Default Gateway 172.29.40.254

DNS Server

Alt. DNS Server

Check ARP

Disable

No IP protocol data will be sent/received via this interface

2. Select the **Disable** checkbox.
3. Click **OK**.

Setting the Time Source

About this task

The base station can obtain its time from the IP Office control unit.

Procedure

1. In the left-hand column select **General**. Select the **NTP** tab.

Configuration	Info	Admin	NTP	Kerberos Server	Certificates	EULA	Logout
General							
LAN							
IP							
LDAP							
DECT							
VoIP							
Unite							
Services							
Administration							
Users							
Device Overview							

Active Settings

Time Server

Alt. Time Server

Interval [min] 60

Timezone Europe - Central European Time (UTC+1)

String CET-1CEST-2,M3.5.0/2,M10.5.0/3

Current Server

Last Sync 26.10.2017 14:20

2. In the **Time Server** field enter the IP address of the IP Office.
3. Click **OK**.

QoS/ToS Settings

About this task

If the network uses QoS/ToS for VoIP traffic, the base station should be configured to use the same settings.

Procedure

1. In the browser connection to the base station, in the left-hand panel select **IP**. Select the **Settings** tab.

2. Set the **ToS Priority - RTP Data** value to match the IP Office's **DSCP (Hex)** value.
3. Set the **ToS Priority - VoIP Signalling** value to match the IP Office's **SIG DSCP (Hex)** value.
4. Click **OK**.

Setting the Base Station as the Master

About this task

A number of menus are disabled until the base station has been set as the master base station for the IP Office DECT R4 system.

Procedure

1. In the left-hand panel select **DECT**, and then select the **Master** tab.

2. Use the **Mode** drop-down box to select **Active**, and click **OK**.

3. Click on the **Reset required!** message.

The screenshot shows the configuration interface with the 'Master' tab selected. The 'Mode' dropdown is set to 'Active'. Below it, a message reads: 'No Admin password. Configure Admin password on DECT/System page.' There are 'OK' and 'Cancel' buttons. At the bottom, a red message says 'Reset required!'.

4. Click **OK**.

The screenshot shows the configuration interface with the 'Master' tab selected. A message reads: 'Reset only if the system is idle (no active calls, etc.)'. There is an 'OK' button.

5. In the left-hand panel select **DECT**. Select the **System** tab.

The screenshot shows the configuration interface with the 'DECT' tab selected in the left-hand panel and the 'System' tab selected in the top navigation. The configuration fields are as follows:

- System Name: DECT
- Password: [masked]
- Confirm Password: [masked]
- Subscriptions: With System AC
- Authentication Code: 1234
- Default Language: English
- Frequency: Europe
- Enabled Carriers: 0 1 2 3 4 5 6 7 8 9 (all checked)
- Coder: G729A, Frame (ms): 60, Exclusive SC

There are 'OK' and 'Cancel' buttons at the bottom.

6. Set and check the following values:

- **System Name**

Enter name to identify the DECT system. This must be a unique name if there are other DECT systems in the same area.

- **Password**

Enter the same password as being used for admin access to the base stations. The default is **changeme**. Re-enter the password in the **Confirm Password** field.

- **Subscriptions**

Select **With System AC**. This allows phones to be subscribed to the system using the system authentication code as set below.

- **Authentication Code**

This code is required by phones during subscription to the DECT system.

- **Default Language**

Select the language required by the customer.

- **Frequency**

You must ensure that the correct region is selected. This affects the frequency used for DECT wireless signalling and other factors.

- Do not adjust the **Coder** options.
- Click **OK**.

Enabling Supplementary Services

About this task

Enabling supplementary services is required for IP Office operation.

Procedure

1. In the left-hand panel select **DECT**, and then select the **Suppl. Serv.** tab.

2. Select **Enable Supplementary Services**.
3. In the **Fix Message Center No.** field enter *17. This is the IP Office default short code for voicemail access. If the IP Office has been configured to use a different short code enter that short code.
4. Click **OK**.

Setting the PBX Switch Mode

About this task

The master base station needs to be configured for the type of PBX and the protocol to use for communication with the PBX.

Procedure

1. In the left-hand panel select **DECT**, and then select the **Master** tab.

The screenshot shows a configuration window with a left-hand navigation menu. The 'DECT' tab is selected, and the 'Master' sub-tab is active. The main area contains the following settings:

- Mode: Active (dropdown)
- IP-PBX: IPO (dropdown)
- PBX Resiliency:
- Protocol: H.323/XMobile (dropdown)
- ARS Prefix:
- International CPN Prefix:
- National CPN Prefix:

Buttons for 'OK' and 'Cancel' are located at the bottom of the configuration area.

2. Using the **PBX** drop-down list, select **IPO**.
3. Check that the **Protocol** is set to **H.323/XMobile**.
4. Click **OK**.
 - The message **Reset required!** is displayed. At this stage further changes are required so do **not** reset the base station.

Configuring IP Trunks

About this task

An IP trunk to the IP Office must be configured. Only one trunk is supported.

Procedure

1. In the left-hand panel select **DECT**, and then select the **Trunks** tab.

The screenshot shows a configuration window with the 'Trunks' sub-tab selected. The 'Trunk List' table is displayed with the following data:

Name	Local Port	CS IP Address	CS Port	Status
Trunk1	1720	192.168.0.210	1720	Active

Buttons for 'OK' and 'Cancel' are located at the bottom of the configuration area.

2. Enter the following settings:
 - **Name:** Set a name that identifies the IP Office system.
 - **Local Port:** Set this to **1720**.
 - **CS IP Address:** Set this field to the IP address of the IP Office system.

- **CS Port** : Set this to **1720**.
3. Click **OK**.
 - The message **Reset required!** is displayed. At this stage further changes are required so do **not** reset the base station.

Entering the Radio Settings

About this task

Having been configured as the master base station, the radio aspect of the base station can be configured. Note that IP Office does not support use of a standby master base station.

Procedure

1. In the left-hand panel select **DECT**. Select the **Radio** tab.

Configuration	System	Suppl. Serv.	Master	Trunks	Radio	Radio config	PARI	SARI	Air Sync	Logout
General										
LAN										
IP										
LDAP										
DECT										
VoIP										
Unite										
Services										
Administration										
Users										
Device Overview										
DECT Sync										
Traffic										
Backup										
Update										

Disable

Master

Name

Password

Master IP Address

Standby Master IP Address

Status No Connection to Master

Uninitialized Master Connections

IP Address	State
192.168.42.210	Up

Reset required!

2. Set the following values:

- **Name**

Set this to match the **System Name** set on the **DECT | System** tab.

- **Password**

Set this to match the **Password** set on the **DECT | System** tab.

- **Master IP Address**

Set the address 127.0.0.1 for the base station to refer to itself. (Alternatively set this to match the IP address assigned to the base station on the **LAN | IP** tab).

- Click **OK**.

- The message **Reset required!** is displayed. At this stage further changes are required so do **not** reset the base station.

Performing an RFP Scan

About this task

The following processes are only required if the DECT system is operating in the same area as other DECT systems.

The Primary Access Rights Identifier (PARI) is a part of the IPBS broadcast identity, which uniquely identifies each DECT system. This PARI is automatically assigned to each master in the system. However, if more than one DECT system operates within the same coverage area, each system need to have a unique PARI assigned in order to differentiate the systems.

To see the occupied system IDs of other Avaya IP-DECT systems within the coverage area, perform an RFP scan using the following procedure:

Procedure

1. Select **Diagnostics**
2. Select **RFP Scan**
3. Click **Start Scanning**

 **Note:**

Executing an RFP scan will terminate all calls on the IPBS.

Entering the PARI

About this task

A Primary Access Rights Identifier (PARI) is required to identify the master base station for the DECT R4 system. Use the following procedure to configure the PARI on the master base station.

Procedure

1. In the left-hand panel select **DECT**. Select the **PARI** tab.



The screenshot shows a configuration window with a left-hand navigation pane and a main content area. The navigation pane has tabs for Configuration, LAN, IP, LDAP, and DECT. The DECT tab is selected. The main content area has tabs for System, Suppl. Serv., Master, Trunks, Radio, Radio config, PARI, SARI, Air Sync, and Logout. The PARI tab is selected. In the main content area, there is a text input field labeled 'System ID' with the value '30' entered. Below the input field are 'OK' and 'Cancel' buttons.

2. Enter a value between 1 and 35. This value must be unique from any other DECT R4 master base station in the area.
3. Click **OK**.

Entering the SARI/PARK

About this task

The SARI is the license for the DECT R4 system.

Procedure

1. In the left-hand panel, select **DECT**. Select the **SARI** tab.

The screenshot shows a configuration window with a left-hand menu and a main content area. The menu includes 'Configuration', 'General', 'LAN', 'IP', 'LDAP', 'DECT', and 'VoIP'. The 'DECT' option is selected. The main content area has tabs for 'System', 'Suppl. Serv.', 'Master', 'Trunks', 'Radio', 'Radio config', 'PARI', 'SARI', 'Air Sync', and 'Logout'. The 'SARI' tab is active, displaying a text input field containing the number '3110024377703' and two buttons labeled 'OK' and 'Cancel'.

2. Enter the SARI code provided with the DECT R4 equipment.
3. Click **OK**.

Configuring Air Sync

About this task

Base stations in the DECT R4 system need to be synchronized with each other. This can be done with a signal as low as -90dB between base stations.

One base station is assigned as the 'air sync master', typically the master base station. Each other base station can sync directly with it or indirectly via a synchronization chain. However, it is preferable that the number of synchronization 'hops' between any particular base station and its air sync master base station is kept as low as possible. To help achieve this it is recommended that the air sync master is placed centrally within the set of base stations.

Where possible, each base station should be placed within synchronization range of more than one base station, which allows the base stations to maintain synchronization should one base station fail or be switched off for maintenance. The process of synchronizing by the shortest route to the air sync master when in synchronization range of multiple base stations is automatic.

Procedure

1. In the left-hand panel, select **DECT**. Select the **Air Sync** tab.

Configuration	System	Suppl. Serv.	Master	Trunks	Radio	Radio config	PARI	SARI	Air Sync	Logout
General										
LAN										
IP										
LDAP										
DECT										
VoIP										
Unite										
Services										
Administration										
Users										
Device Overview										

Sync Mode

Reference RFPI

Alternative reference RFPI

Sync Region

Action at reference sync failure

Resynchronize on command

Resynchronize every day at

Resynchronize every at

2. Set the **Sync Mode** to **Master**.
3. Click **OK**.

Advanced Scenario: Separated Locations

In most scenarios, the master base station (Standard or Compact) is also used as the air sync master for all the other slave base stations and that is the scenario documented in this manual. However, in scenarios where you have base stations in separate locations that are not within synchronization range of each other, it is permissible to assign separate air sync masters in each location. However, there must be absolutely no overlap (<-90dB) between the separate groups of base stations. Any overlap will cause frequent loss of synchronization.

Having separate locations, each with its own synchronization, is done through the settings on the **DECT | Air Sync** tab of each base station. For each location, set the same **Sync Region** number for all the base stations at that location, using a different number for each location. In addition, use the **Sync Mode** drop-down menu to configure one of the base stations in each location as the **Master** base station.

* Note:

In deployments in mixed systems with IP Base Stations and IP-DECT Gateways, the IP-DECT Gateways need to be physically interconnected for the purpose of radio synchronization. When configuring an IP-DECT Gateway as an air sync master, use sync region 0. All other base stations should be configured as sync slaves. Systems with IPBS in sync regions that have only IPBS should use non-zero sync region number(s) and be configured with at least one sync master with the remaining IPBSs configured as sync slaves.

Configuring Air Sync in Separated Locations

Procedure

1. For each base station in the system, configure a **Sync Region** number under the **DECT | Air Sync** tab in the Device Manager and click **OK**.

All the base stations in a single region should contain the same **Sync Region** number, but each Sync Region must have its own unique number. By default, **Sync Region = 0**, which means that no region is defined.

- For each new Sync Region created, configure one base station as the **Master** using the **Sync Mode** drop-down menu and click **OK**.

You must configure at least one master base station per region.

Integrating the IP Office Directory

About this task

With IP Office Release 6 and later, the master base station can obtain directory information direct from the IP Office control unit rather than the system requiring an AIWS unit to do this. This requires the master base station to be able to access the IP Office control unit using TFTP. The directory import is limited to 6000 entries.

Note that enabling directory integration via the master base station disables support for SMS. If both SMS and directory integration are required then an AIWS unit must be used.

Procedure

- In the left-hand panel, select **Phonebook**.

- Select **Enable**.

3. Select the other settings as shown above, with the **Server IP Address** set to the IP address of the IP Office control unit.
4. Click on **OK**.

Resetting a Master Base Station

About this task

Having completed the configuration changes, the master base station should be reset.

Procedure

1. In the left-hand panel, select **Reset**. Select the **Reset** tab or **Idle-Reset** tab.

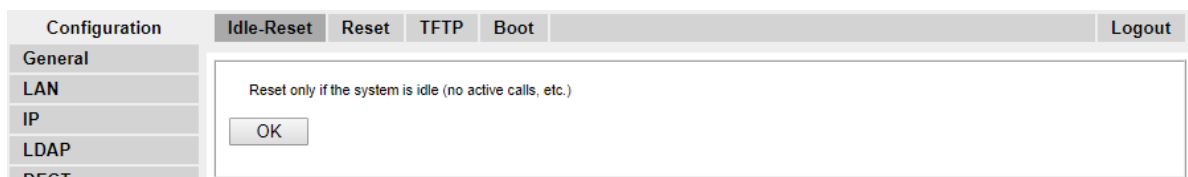

2. Click **OK**.

Checking Master Base Station Radio

About this task

Following the reset, the operation of the radio part can be checked.

Procedure

1. In the left-hand panel, select **DECT**. Select the **Radio** tab.

Configuration	System	Suppl. Serv.	Master	Trunks	Radio	Radio config	PARI	SARI	Air Sync	Logout
General										
LAN										
IP										
LDAP										
DECT										
VoIP										
Unite										
Services										
Administration										
Users										
Device Overview										
DECT Sync										
Traffic										
Backup										
Update										
Diagnostics										
Reset										
<p>Disable <input type="checkbox"/></p> <p>Master</p> <p>Name <input type="text" value="IPBS2"/></p> <p>Password <input type="password" value="*****"/></p> <p>Master IP Address <input type="text" value="192.168.0.227"/></p> <p>Alt. Master IP Address <input type="text" value="192.168.0.226"/></p> <p>Status <input type="text" value="Connected to Master 192.168.0.227"/></p> <p>Max RTP Streams</p> <p>Number of Streams <input type="text"/></p> <p>Received Configuration</p> <p>SARI 31100243777703</p> <p>RFPI 9014AC1008</p> <p>Subscriptions Disable</p> <p>Authentication Code</p> <p>Default Language English</p> <p>Frequency 1920-1930 MHz (North America)</p> <p>Enabled Carriers 23 24 25 26 27</p> <p><input checked="" type="checkbox"/> <input checked="" type="checkbox"/> <input checked="" type="checkbox"/> <input checked="" type="checkbox"/> <input checked="" type="checkbox"/></p> <p>Early Encryption disabled</p> <p>ICE enabled</p> <p>Coder 20 ms</p> <p>Secure RTP Key Exchange No encryption</p> <p>OK Cancel</p>										

2. The **Status** should indicate **Connected to Master**.
3. The **Received Configuration** settings should match the parameters entered during configuration.

Configuring IP Slave Base Stations

The base station installation process consists of the following stages:

1. [Defaulting the Base Station](#) on page 193
2. [Accessing the Base Station Configuration](#) on page 194
3. [Updating the Base Station Firmware](#) on page 195
4. [Setting the Base Station IP Address](#) on page 197
5. [Setting the Base Station to Slave Mode](#) on page 198
6. [Resetting the Base Station](#) on page 200
7. [Checking the Base Station Configuration](#) on page 200

Pre-Requisites

- IP Office connected to the LAN with IP DECT line configured for master base station IP address.

Information

- DECT R4 SARI.
- Base Station IP Addresses.
- Detailed plans from the site survey indicating the intended base station locations, LAN sockets and if necessary power supply outlets.

Parts Required

- Base station

Includes:

- Base station.
- Two 3.5mm screws and two 6mm wall plugs suitable for wall mounting onto a solid wall (brick or similar).
- 1.2 metre (4 foot) LAN cable. If this is replaced with a longer cable the replacement should be a CAT5 Ethernet LAN cable.

Important:

For DECT firmware 10.0 and higher, supported with IP Office Release 10.0 and higher, IPBS1 base stations are only supported as slave radio base stations . IPBS1 base stations are no longer supported in other roles, for example as master base stations. For systems being upgraded, any existing IPBS1 base station being used such other roles must first be replaced in that role with an IPBS2 or IPBL1.

- If using Power over Ethernet:
 - The base station supports Power over Ethernet, IEEE 802.3af, class 2.
- If not using Power over Ethernet:
 - Base station power supply unit.

Required if not using Power over Ethernet to power the base station. Note that the base station power supply units include an 8 metre (26 feet) cable from the PSU to the base station. Check that you have the correct type of power supply unit for the locale.

- BSX-0013: Europe (except United Kingdom).
 - BSX-0014: United Kingdom.
 - BSX-0015: USA/Canada.
 - BSX-0016: Australia.
 - Mains power outlet socket.
- LAN Socket.

Tools

- Programming PC with DECT R4 software.
- Web browser.
- Drill and drill bits suitable for the selected wall mounting position of the IPBS.
- Screwdrivers for use with the screws selected for IPBS wall mounting.

Defaulting the Base Station

About this task

This process will default a base station or IP DECT Gateway, erasing its configuration. After the unit restarts it will default to the IP address 192.168.0.1/255.255.255.0.

Note:

The following instructions assume you are installing an IPBS2, which has one LED lamp. The IPBS1 has two LED lamps. For more information on the base station LEDs and what their statuses indicate, see [Base Station Status Lamps](#) on page 14.

Procedure

1. With only the power supply connected, switch the base station on.

The LED on the base station flashes red if no Ethernet is detected.

2. Wait approximately five seconds.

3. Press and hold the **Reset** button on the base station for approximately 10 seconds..

The LED on the base station will change to a quick flash, then the LED will go out, and then the LED returns to a slower flash.

4. Release the Reset button and wait for the base station to reset.

The LED should turn back on to solid amber.

5. Quickly press the **Reset** button once.

The base station reboots with default settings. The default IP is 192.168.0.1, with DHCP on, but not active. If you wish to activate DHCP reset the base station again.

Note:

Avaya recommends disabling the DHCP on the base station and configuring the system with static IP addresses. For information on disabling DHCP on the base station, see [Set the Base Station IP Address](#) on page 57.

Accessing Base Station Configuration

Procedure

Depending on whether DHCP is being used or not:

- a. Connect the base station to the network or PC using the LAN cable.
- b. If connected directly to the base station, change your programming PC's network address to 192.168.0.200 with subnet mask 255.255.255.0.
- c. If both your PC and the base station are connected to a LAN network with DHCP server, ensure your PC is set to act as a DHCP client or has a fixed address that is valid on the network.
- d. Start your web browser and enter the http:// or https:// followed by the IP address of the base station. The default IP address is 192.168.0.1. If a security certificate warning is displayed, select to continue to this website.
- e. The base station responds with its login menu.



- f. Select **System administration**. Enter the default user name (**admin**) and password (**changeme**) and click **Login**.
- g. A summary of the current logins is displayed. Click **OK**.
- h. The configuration menu for the base station is displayed.

Configuration	Info	Admin	EULA	Logout
General				
LAN				
Administration				
Backup				
Update				
Diagnostics				
Reset				
	Version	IPBS[10.0.5], Bootcode[10.0.5], Hardware[IPBS1-Y4/PD]		
	Serial Number	09AD15300066		
	MAC Address (LAN)	00-01-3e-01-6f-9c		
	DRAM	32 MB		
	FLASH	8 MB		
	Coder	8 Channels of G.711,G.729,G.723		
	SNTP Server	192.168.0.214		
	Time	** * * * *		
	Uptime	0d 1h 38m 42s		

- i. Note the software levels shown in the **General | Info** menu. These will determine if the base station software needs to be upgraded.

*** Note:**

Compact Base Stations have advanced menu options hidden by default. To enable or disable Advanced Administration menus, see [Select Administration Mode](#) on page 62 .

Updating Base Station Firmware

About this task

The base station may need to be upgraded to match the software version supplied for use with the IP Office. The base station software consists of two parts, a firmware file and a boot file. All base stations in a DECT system should use the same version of software.

Procedure

1. Browse into the base station configuration and note the software levels shown by the **Version** line.

Configuration	Info	Admin	EULA	Logout
General				
LAN	Version IPBS[10.0.5], Bootcode[10.0.5], Hardware[IPBS1-Y4/PD]			
Administration	Serial Number 09AD15300066			
Backup	MAC Address (LAN) 00-01-3e-01-6f-9c			
Update	DRAM 32 MB			
Diagnostics	FLASH 8 MB			
Reset	Coder 8 Channels of G.711,G.729,G.723			
	SNTP Server 192.168.0.214			
	Time ** ** ** **			
	Uptime 0d 1h 38m 42s			

2. Check that these match the versions supplied with the IP Office administration software.

Ensure that you are checking against the correct folder for an IPBS1 or IPBS2 base station. If they do not match, you must upgrade the base station.

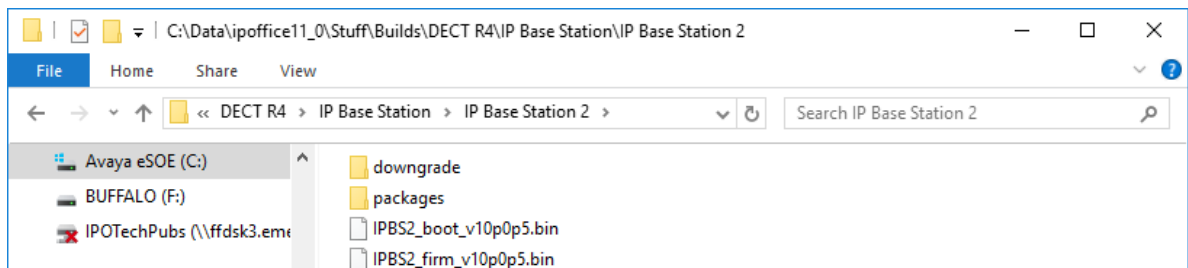

If both software files need to be upgraded, the boot file should be upgraded first.

3. In the left-hand column, under the **Administration** menu, select **Update** and then select the **Boot** tab.

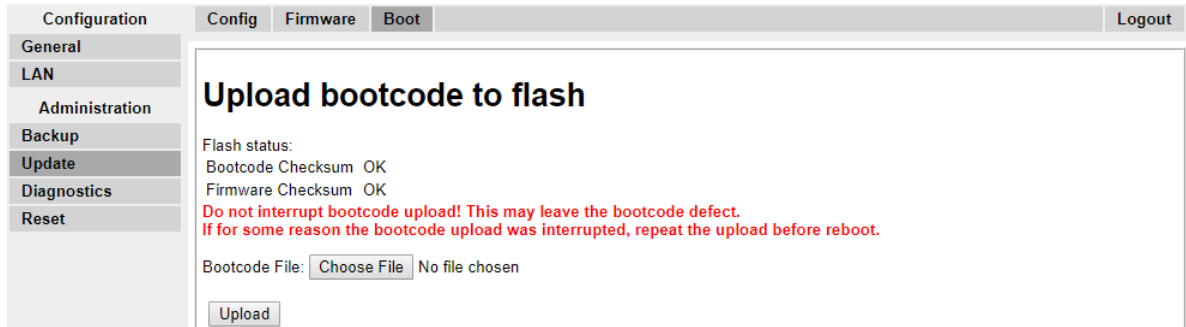

4. Click on the **Browse** button and browse to the **IP Base Station 2** sub-folder of the IP DECT R4 software.
5. Select the appropriate boot file for the upgrade you are performing.
6. Click **OK**.
7. Click on the **Upload** button.

The browser shows the progress of the upload and upgrade. It will indicate when the process has been completed.



8. If necessary, repeat the process to upgrade remaining base stations.
9. To upgrade the base station firmware file, select **Update** and then select the **Firmware** tab.

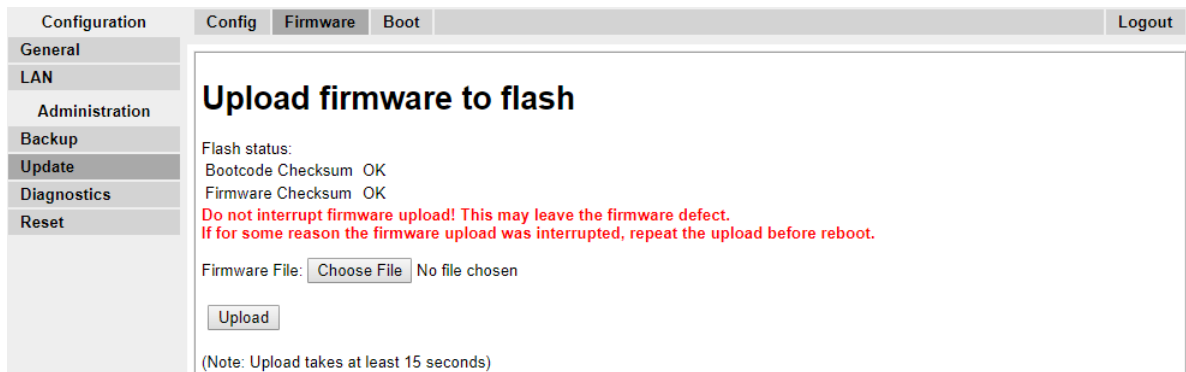

10. Click on the **Browse** button and browse to the **IP Base Station** sub-folder of the IP DECT R4 software you previously extracted onto the programming PC.
11. Select the appropriate firmware file for the upgrade you are performing,
12. Click **OK**.
13. Click on the **Upload** button.

The browser shows the progress of the upload and upgrade. It will indicate when the process has been completed.

14. Click on **Reset**.
15. Log in again. The **General | Info** tab should now list the new firmware.

If necessary, repeat the process for the remaining base stations using the **Update | Firmware** menu.

If necessary, update the base station firmware for base stations that will be connected to an IP DECT Gateway using the **Update | RFPs** menu.

Setting a Base Station IP Address

About this task

During initial installation the IP address of a base station defaults to 192.168.0.1. The process below can be used to change the DHCP mode and IP address of a base station.

Procedure

1. From the base station configuration window, in the left-hand column, select **LAN**.
2. Select the **IP** tab.

Configuration	DHCP	IP	802.1X	LLDP	Logout
General					
LAN					
Administration					
Backup					
Update					
Diagnostics					
Reset					

Active Settings	
IP Address	192.168.0.226
Network Mask	255.255.255.0
Default Gateway	192.168.0.1
DNS Server	
Alt. DNS Server	
Check ARP	<input type="checkbox"/>

OK Cancel

- a. Enter the required **IP Address** and **Network Mask** for the base station. The other settings are optional.
- b. Click **OK**.

*** Note:**

The menu will prompt you with the message **Reset Required**. Do not click this or reset the base station at this stage.

- c. Select the **DHCP** tab.

Configuration	DHCP	IP	802.1X	LLDP	Logout
General					
LAN					
Administration					
Backup					

Mode	disabled	Currently - disabled
------	----------	----------------------

OK Cancel

- d. Using the **Mode** drop-down, select **Disabled**.
- e. Click **OK**.

- f. Select **Reset** and then select the **Reset** tab.
- g. Click **OK**.
- h. Depending on your base station, wait for the LED to return to solid blue or solid green.
- i. Log in again using the new IP address.

Setting a Base Station to Slave Mode

About this task

There can be only one master base station in the IP Office DECT R4 system. In this process we check that the base station is not set to act as a master and then configure its radio settings to access the master base station.

Procedure

1. In the left-hand column, select **DECT**. Select the **Master** tab.

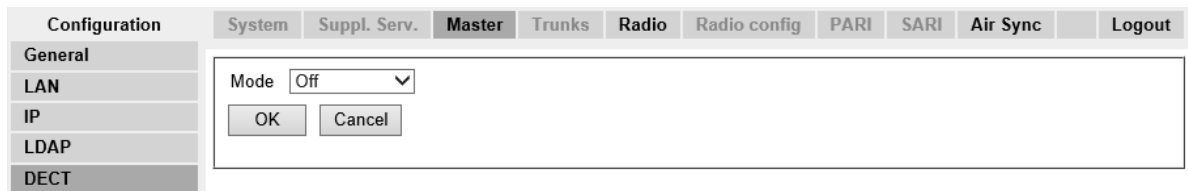

The screenshot shows a configuration interface with a left-hand menu and a main content area. The left-hand menu has the following items: Configuration, General, LAN, IP, LDAP, and DECT. The main content area has a top navigation bar with tabs: System, Suppl. Serv., Master, Trunks, Radio, Radio config, PARI, SARI, Air Sync, and Logout. The 'Master' tab is selected. Below the tabs, there is a 'Mode' dropdown menu set to 'Off' and two buttons: 'OK' and 'Cancel'.

2. Check that the **Mode** is set to **Off**.
3. Click **OK**.
4. Select the **Radio** tab.

The screenshot shows the 'Master' configuration tab in the DECT configuration interface. The 'Name' field is set to 'IPBS2', 'Password' is masked with dots, 'Master IP Address' is '192.168.0.227', and 'Alt. Master IP Address' is '192.168.0.226'. The status shows 'Connected to Master 192.168.0.227'. Below this, the 'Received Configuration' section lists various parameters like SARI, RFPI, Subscriptions, and Frequency.

5. Set the following details:

- **Name**

Set this to match the **System Name** set on the master base station's **DECT | System** tab.

- **Password**

Set this to match the **Password** set on the master base station's **DECT | System** tab.

- **Master IP Address**

Enter the IP address of the master base station set on its **LAN | IP** tab.

- Click **OK**.

- Select the **Air Sync** tab.

The screenshot shows the 'Air Sync' configuration tab in the DECT configuration interface. The 'Sync Mode' dropdown is set to 'Slave', 'Sync RFPI' and 'Alternative sync RFPI' are empty text boxes, and 'Sync Region' is set to '0'.

- Set the **Sync Mode** to **Slave**.

- Click **OK**.

Resetting a Base Station

Procedure

1. In the left-hand panel, select **Reset**. Select the **Reset** tab or **Idle-Reset** tab.

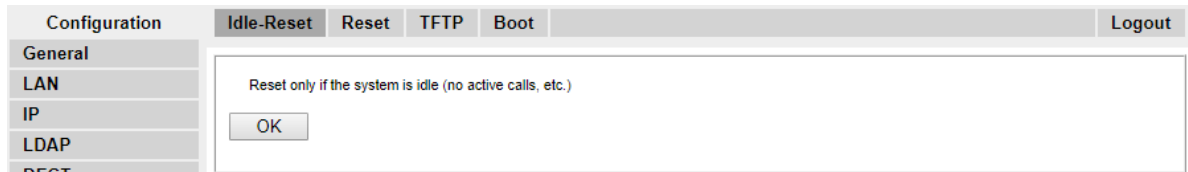

2. Click **OK**.

Checking a Base Station Signaling Status

To check the signaling between the base stations, use the following procedures.

Master Base Station

Procedure

1. In the left-hand column select **Device Overview**. Select the **Radios** tab. The details of the base stations within the system are displayed.

The screenshot shows a configuration window with a left-hand menu containing 'Configuration', 'General', 'LAN', 'DECT', 'Services', 'Administration', 'Users', and 'Device Overview'. The 'Configuration' tab is active, and the 'Radios' sub-tab is selected. The main content area displays a table titled 'Static Registrations' with the following data:

Name	RFPI	IP Address	Sync	LDAP	Device Name	Version	Connected Time
IPBS-01-5d-e0	9014CC1008	192.168.42.210	Master	OK	-	IP-DECT Base Station [3.1.16/v3.080915/IPBS1-Y3/PC]	0d 18h 47m 42s
IPBS-01-5d-f0	9014CC2009	192.168.42.212	Slave	OK	-	IP-DECT Base Station [3.1.16/v3.080915/IPBS1-Y3/PC]	0d 0h 2m 0s

2. Select the **Air Sync** tab. The status of wireless synchronization between the master and other base stations is displayed.

Configuration	Radios	Air Sync																		
General	Base station sync status State Master																			
LAN	Alternative sync bearers <table border="1"> <thead> <tr> <th>RFPI</th> <th>Carrier</th> <th>Slot</th> <th>Hop</th> <th>RSSI</th> <th>FER</th> </tr> </thead> <tbody> <tr> <td>9014CC2009</td> <td>4</td> <td>1</td> <td>1</td> <td>-32</td> <td>2</td> </tr> <tr> <td></td> <td>5</td> <td>4</td> <td>1</td> <td>-32</td> <td>0</td> </tr> </tbody> </table>		RFPI	Carrier	Slot	Hop	RSSI	FER	9014CC2009	4	1	1	-32	2		5	4	1	-32	0
RFPI	Carrier	Slot	Hop	RSSI	FER															
9014CC2009	4	1	1	-32	2															
	5	4	1	-32	0															
IP																				
LDAP																				
DECT																				
UNITE																				
Administration																				
Users																				
Device Overview																				

Slave Base Station

Procedure

In the left-hand column select **Device Overview**. Select the **Air Sync** tab.

Configuration	Radios	Air Sync												
General	Base station sync status State Slave, synchronized Sync offset -96 ns Drift 0.9166 PPM													
LAN	Active sync bearer <table border="1"> <thead> <tr> <th>RFPI</th> <th>Carrier</th> <th>Slot</th> <th>Hop</th> <th>RSSI</th> <th>FER</th> </tr> </thead> <tbody> <tr> <td>9014CC1008</td> <td>4</td> <td>7</td> <td>0</td> <td>-38</td> <td>0</td> </tr> </tbody> </table>		RFPI	Carrier	Slot	Hop	RSSI	FER	9014CC1008	4	7	0	-38	0
RFPI	Carrier	Slot	Hop	RSSI	FER									
9014CC1008	4	7	0	-38	0									
IP	Alternative sync bearer <table border="1"> <thead> <tr> <th>RFPI</th> <th>Carrier</th> <th>Slot</th> <th>Hop</th> <th>RSSI</th> <th>FER</th> </tr> </thead> <tbody> <tr> <td>9014CC1008</td> <td>0</td> <td>11</td> <td>0</td> <td>-38</td> <td>11</td> </tr> </tbody> </table>		RFPI	Carrier	Slot	Hop	RSSI	FER	9014CC1008	0	11	0	-38	11
RFPI	Carrier	Slot	Hop	RSSI	FER									
9014CC1008	0	11	0	-38	11									
LDAP														
DECT														
UNITE														
Administration														
Users														
Device Overview														
Traffic	Counters Sync lost 0 Hop value 1													
Backup														
Update														

Mounting a Base Station

About this task

The base station can now be powered down and mounted in its intended operating position. The removable bracket on the back of the base stations can be used for either wall mounting using two screws suitable for the surface or for mounting on columns using two metal bands.

Mounting a Base Station using a Wallmount

About this task

Remove the mounting bracket from the base station. Use it as a template for marking the screw fixing holes. Note the diagram below indicating the required clearance for attaching the base station onto the mounting bracket.

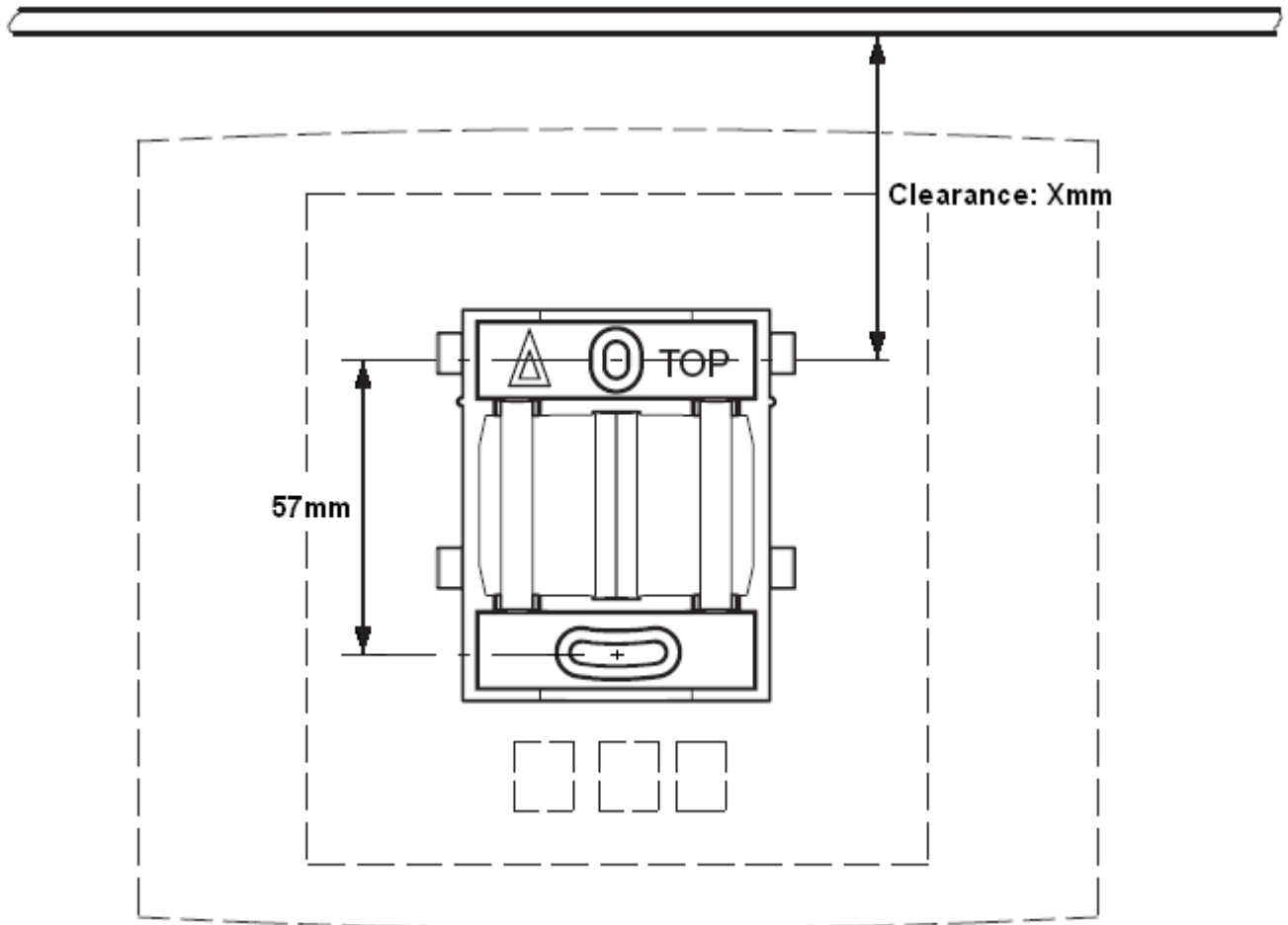

Procedure

1. Hold the mounting bracket with its flat side against the wall with the text 'TOP' upwards and mark the two holes. Observe the minimum distance between the top screw hole and the ceiling. This depends on the base station type as follows:

Base Station Type	Internal Aerials	External Aerials
IPBS1 or Digital Base Station	65mm	160mm
IPBS2	100mm	195mm

2. Drill the two holes using a 6mm diameter drill and insert the included wall plugs.
3. Position the mounting bracket with its flat side to the wall and fasten it with the two included 3.5mm diameter screws.

Mounting a Base Station on a Column/Pillar

The mounting bracket can be fixed to a pole of 45mm diameter or greater, or a beam of 50mm width minimum by using a strap or flexible metal band less than 30 mm wide. A suitable strap or flexible metal band is not included with the base station.

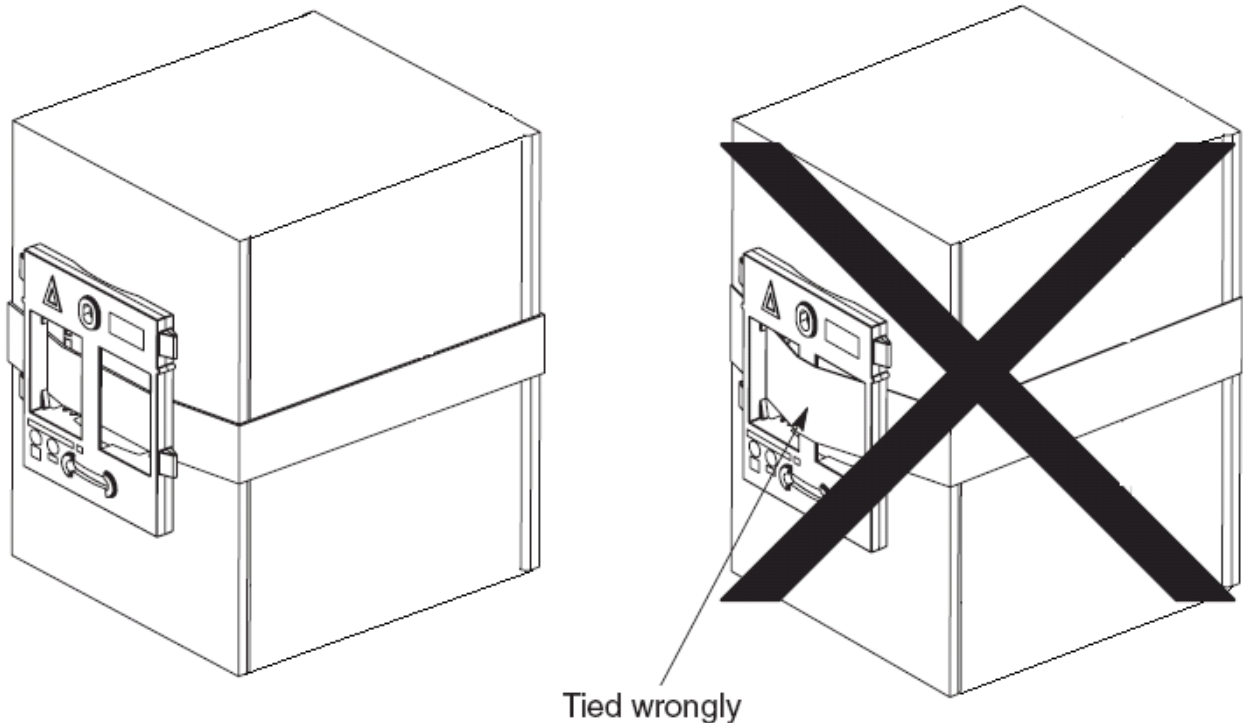

Note: Mounting a wireless base station directly on a steel beam or pillar could result in signal disruptions, such as dead zones or reflections. If it is absolutely necessary to mount the base station on a metallic surface, use spacers to separate the base station from the surface by 20-25 cm.

Phone Subscription

Once the master base station has been configured and is connected to the IP Office, you can begin phone subscription.

There are two methods of subscription; anonymous phone subscription and pre-configured phone subscription. Both methods require the DECT users to be pre-configured in the master base station configuration. However, anonymous phone subscription allows the user pre-configuration to be done without knowing the IPEI of the DECT phone the user will actually use.

The anonymous phone installation process consists of the following stages:

1. [Allowing Subscription](#) on page 204.

2. [Creating User Entries](#) on page 206.
 3. [Subscribing a Phone](#) on page 208.
 4. [Completing Anonymous Login](#) on page 211.
 5. [Disabling Subscription](#) on page 211.
- This method makes changes to the IP Office system configuration. Ensure that no copies of the configuration are open in Manager during subscription as sending that configuration back to the IP Office system will remove the subscriptions and require the handsets to be resubscribed.

Pre-Requisites

- Master base station installed and connected to the network.
- IP Office connected to the network.

Information

- Service user name and password for IP Office configuration.
- User names and extension numbers for the DECT phones.
- Phone IPEI numbers if using pre-configured installation mode.

Tools

- **IP Office Manager.**
- **Device Manager**



The software installed on each handset may need to be upgraded to match that supplied with the DECT R4 software. This is done using the Windows Device Manager software to upgrade phones via an advanced charger or using AIWS Device Manager to upgrade phones over the air.
- Web browser (Internet Explorer or Firefox are supported).

Allowing Subscription

Before phones are subscribed, subscription needs to be allowed by both the IP Office and the DECT R4 system.

Enabling IP Office Subscription

Procedure

1. Start IP Office Manager and receive the configuration from the IP Office system.
2. In the left-hand navigation pane, click on  **Line** icon.
3. Select the  **IP DECT Line**.

4. Select the **Gateway** tab.

Line Gateway VoIP

Auto-Create Extension

Auto-Create User

Enable DHCP Support

Boot File

ADMM MAC Address

VLAN ID

Base Station Address List

Enable Provisioning

SARI/PARK

Subscriptions

Authentication Code

Enable Resiliency

Status Enquiry Period

Prioritize Primary

Supervision Timeout

5. Check that the **Auto-Create Extension** and **Auto-Create User** options are selected.

6. Click **OK**.

7. Send the configuration back to the IP Office.

Master Base Station

Procedure

1. Access the master base stations configuration.
2. In the left-hand panel select **DECT**. Select the **System** tab.

The screenshot shows a configuration window with a left-hand navigation pane and a main configuration area. The navigation pane includes: Configuration, System, Suppl. Serv., Master, Trunks, Radio, Radio config, PARI, SARI, Air Sync, Logout, General, LAN, IP, LDAP, DECT, VoIP, Unite, Services, Administration, Users, Device Overview, DECT Sync, Traffic, Backup, and Update. The 'DECT' option is selected. The main configuration area contains the following fields and options:

- System Name: DECT
- Password: [masked]
- Confirm Password: [masked]
- Subscriptions: With System AC (dropdown)
- Authentication Code: 1234
- Default Language: English (dropdown)
- Frequency: Europe (dropdown)
- Enabled Carriers: 0-9, each with a checked checkbox
- Coder: G729A (dropdown)
- Frame (ms): 60
- Exclusive:
- SC:

Buttons for 'OK' and 'Cancel' are located at the bottom of the configuration area.

3. Check that the **Subscriptions** field:

- **With System AC**

Select this option to allow anonymous subscription of phones.

- **With User AC**

Select this option to allow subscription against user entries.

- Note the number set in the **Authentication Code** field. This number is used as part of the anonymous subscription.

- Click **OK**.

Creating User Entries

About this task

Subscription requires a user entry within the master base station configuration. On completion of subscription, matching extension and user entries are automatically created in the IP Office configuration.

Procedure

1. In the left-hand panel, select **Users** under the **Administration** menu. Select the **Users** tab.

Configuration	Users	Anonymous	Logout
General	<div style="border: 1px solid black; padding: 5px;"> PARK 3110024377703 PARK 3rd pty 2110024534 Master Id 0 <input type="text"/> show new </div>		
LAN			
IP			
LDAP			
DECT			
VoIP			
Unite			
Services			
Administration			
Users			

2. Click **new**. A dialogue is displayed for entry of user details.

Edit User - Google Chrome

192.168.0.227/GW-DECT/mod_cmd_login.xml?cmd=show&user-new=*&xsl=asc_dect_edit...

User type

User

User Administrator

Long Name

Display Name

Number

IPEI / IPDI

Auth. Code

OK Apply Cancel

3. Enter the user details:

- **Long Name**

This name is used for information within the DECT R4 system settings.

- **Display Name**

This name displayed on the phone when idle. It is also the name used for the user created in the IP Office configuration. The name must be unique.

- **Number**

This will be the extension number of the phone on both the IP Office and DECT R4 systems. The number must be unique.

*** Note:**

The remaining two fields should not be completed if you want to use anonymous subscription. This removes the requirement of knowing the phone IPEI numbers during installation.

• **IPEI/IPDI**

The phones IPEI number. For 3720, 3725 phones this is printed on the label inside the phones battery compartment. The IPEI can also be viewed from the phone UI.

• **Auth. Code**

The account code that should be used when the phone is subscribed.

• Click **OK**.

• Repeat the process for any other phones that you want to subscribe.

• Within the **Users | Users** tab, click on **show** to display a list of the configured users.

Long Name	No	Display	IPEI / IPDI	AC	Prod	SW	EE	Registration
Extension400	400	Extn400		1945				Not Subscribed
Extension401	401	Extn401		1503				Not Subscribed

• The phones configured will be displayed. You can now begin subscribing the phones.

Subscribing a Phone

About this task

Using the Telephone user interface, perform the following procedure to subscribe the handsets.

- Switch on the phone:
 - **3720:** Select **Menu | Settings | System | Subscribe**.
 - **Others:** Select **Menu | Connections | System | Subscribe**.

Display	Actions
Display	Actions

Table continues...





Display	Actions
 <p>Abc</p> <p>IPDI: 0364704336127 User ID 361</p> <p>Next Clear Back</p>	<p>Details of the phone's current subscription are displayed. Select Next.</p>
 <p>Abc</p> <p>IPDI: 0364704336127 System name</p> <p>Next Clear Back</p>	<p>The System name is just used by the phone to identify the different subscriptions it may have. Enter any name and select Next.</p>
 <p>Subscribe</p> <p><input type="radio"/> Integral 5 <input type="radio"/> Integral Ent. <input checked="" type="radio"/> IP-DECT <input type="radio"/> Other</p> <p>Next Clear Back</p>	<p>The phone will display a list of telephone system types to which it can connect. Scroll the selected option to IP-DECT and select Next.</p>
 <p>123</p> <p>PARK: 3110024377703</p> <p>AC:</p> <p>Next Clear Back</p>	<p>The phone now requires the PARK (SARI) and AC (authentication code) of the system to which it should subscribe.</p> <p>Enter the PARK and then scroll to the AC field. Enter the System AC and select Next.</p>
 <p>123</p> <p>PARK: 3110024377703</p> <p>Protection on?</p> <p>Yes No Back</p>	<p>The Protection on? prompt is displayed.</p> <ul style="list-style-type: none"> • If you select No, the user can delete the subscription from the list of subscriptions known by the phone. • If you select Yes, the user cannot delete the subscription.

Table continues...

Display	Actions
	<p>A summary of the subscription details is shown. Check that the values are correct</p>
	<p>Select OK.</p> <p>The phone broadcast for DECT systems to which it can subscribe.</p>
	<p>When a DECT system is located, the handset will attempt to subscribe to that system.</p>
	<p>The success or failure of the subscription is indicated.</p>

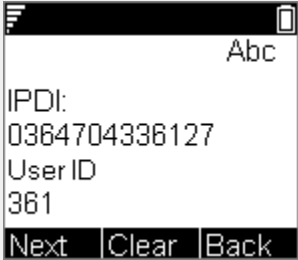
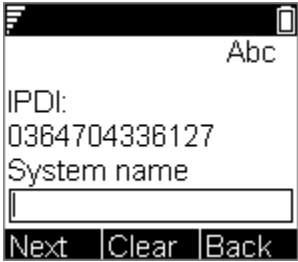
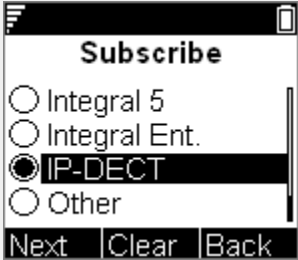
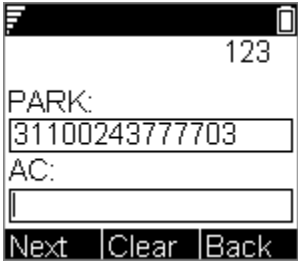
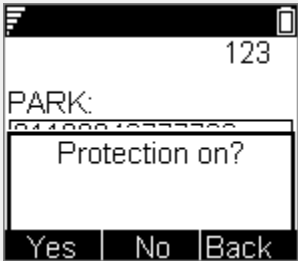
3701/3711 Phone Subscription

Procedure

1. Switch on the phone.
2. Select **Menu | System | Subscription | Subscribe HS**.
3. Select **PABX-PIN**.
4. Enter the authentication code.

Result

1. The phone is subscribed anonymously and should display **Please Login**.

Completing Anonymous Login

About this task

In the master base station configuration select the **Users | Anonymous** tab. This tab shows those phones currently anonymously subscribed to the DECT system. The DECT system will allow up to 8 anonymous devices to be subscribed at the same time.

Configuration	Users	Anonymous	Logout
General	036470433612 Delete		
LAN			
IP			
LDAP			
DECT			
UNITE			
Services			
Administration			
Users			

This process changes the anonymous subscription to a known subscription. While a phone is in anonymous subscription state it displays a screen showing **Please login**.

Procedure

To login, dial ***M*N*AC#** where:

- **M** is the DECT system's **Master Id**. This is shown on the base station's **Users | Users** tab.
 - **N** is the extension number required. This must match an existing unsubscribed user entry on the **Users | Users** tab in the master base station configuration.
 - **AC** is the **User Authentication Code**.
- .
- For example, on a system with master ID 0, to register an anonymously subscribed device as extension 403, dial ***0*403*AC#**.

Disabling Subscription

About this task

When all DECT phones have been subscribed, Avaya recommends that you disable any further subscriptions.

Ensure that no other copies of the configuration are open in Manager during subscription, as sending such a copy of the configuration back to the IP Office system will replace the

subscriptions and require the handsets to be subscribed again. Following any handset subscription, a new copy of the configuration should always be loaded in IP Office Manager if any other configuration changes are required.

Procedure

1. Access the master base station configuration.
2. In the left-hand panel select **DECT**.

Configuration	System	Suppl. Serv.	Master	Trunks	Radio	Radio config	PARI	SARI	Air Sync	Logout
General										
LAN										
IP										
LDAP										
DECT										
VoIP										
Unite										
Services										
Administration										
Users										
Device Overview										
DECT Sync										
Traffic										
Backup										
Update										

System Name	DECT
Password	••••••••
Confirm Password	••••••••
Subscriptions	With System AC
Authentication Code	1234
Default Language	English
Frequency	Europe
Enabled Carriers	0 1 2 3 4 5 6 7 8 9 <input checked="" type="checkbox"/> <input checked="" type="checkbox"/> <input checked="" type="checkbox"/> <input checked="" type="checkbox"/> <input checked="" type="checkbox"/> <input checked="" type="checkbox"/> <input checked="" type="checkbox"/> <input checked="" type="checkbox"/> <input checked="" type="checkbox"/> <input checked="" type="checkbox"/>
Coder	G729A Frame (ms) 60 Exclusive <input type="checkbox"/> SC <input type="checkbox"/>
<input type="button" value="OK"/> <input type="button" value="Cancel"/>	

3. Select the **System** tab.
4. Select **Disabled** in the **Subscriptions** field.
5. Click **OK** to save the configuration back to the IP Office system.

Glossary

The following are definitions for common abbreviations used within the DECT R4 system applications:

Item	Definition
Item	Definition
DECT R4 System	For the purpose of this document, a "DECT R4 system" refers to the configuration of a DECT R4 solution on one IP-DECT Line created on one IP Office, not across an entire IP Office solution, however complex that solution might be.
AIWS	Avaya In-Building Wireless Server
CAP	Common Access Profile
DECT	Digital Enhanced Cordless Telecommunications; global standard for cordless telephony.
ELISE	Embedded Linux SErver; a term for the AIWS.
FER	Frame Error Rate
GAP	Generic Access Profile; DECT standard.
IPBS	IP-DECT Base Station
IPDI	At delivery of the telephone, IPEI and IPDI are the same and either can be used for network subscription. If one telephone is replaced with another using the Easy replacement procedure the IPDI will be exchanged and IPEI and IPDI will no longer be the same. If the IPEI and the IPDI differ, the IPDI shall be used for network subscription.
IPEI	International Portable Equipment Identity; the unique global GAP identity number for the phone. This code is needed for the system administrator to enable network subscription.
PARI	Primary Access Rights Identity
PARK	Portable Access Rights Key
PBX	PBX Private Branch Exchange; the telephone system within an enterprise that switches calls between local lines and allows all users to share a certain number of external lines.

Table continues...

Glossary

Item	Definition
PDM	Portable Device Manager
PP	Portable Part; a term for DECT phones.
RFP	Radio Fixed Part; a term for DECT base-stations.
RFPI	Radio Fixed Part Identity
SARI	Secondary Access Rights Identifier
SS	Signal Strength
SST	Site Survey Tool
WSM	Wireless Services and Message; the module that enables wireless services like central phone book and messaging to and from the portable devices (an alternate term for the AIWS).

Index

Special Characters

*17 [183](#)

Numerics

1720 [184](#)

192.168.0.1 [55](#)

3720 [7](#), [19](#)

3725 [7](#), [19](#)

3725 Site Survey Mode [40](#)

A

Aerials [9](#), [15](#)

Air Sync [70](#), [187](#)

air synch master [39](#)

AIWS [7](#), [28](#)

 Browse [137](#)

 Cover [134](#)

 Device Manager [117](#)

 Installation [132](#)

 IP Address [155](#)

 Replacing the Cover [153](#)

 Status Lamp [30](#)

 Switch Off [152](#)

 Upgrade [163](#)

 Wall Mount [152](#)

Allow Subscription [84](#), [204](#)

Anonymous Login [211](#)

Antenna [15](#)

Auth. Code [206](#)

Authentication Code [84](#), [181](#), [204](#)

Avaya In-Building Wireless Server [7](#), [28](#)

B

Backs up my IP Dect Phones [103](#)

Base Station [7](#), [9](#)

 Access the Configuration [56](#), [73](#), [174](#), [194](#)

 Browse [56](#), [73](#), [174](#), [194](#)

 IP Address [57](#), [74](#), [177](#), [197](#)

 Mounting [80](#)

 Reset [190](#), [200](#)

 Reset Switch [34](#)

 Restart [34](#)

 Status Lamps [14](#)

 Time Source [180](#)

Base Station Mirroring [98](#)

Battery [19](#)

 AIWS [136](#)

 RTC [136](#)

Bear [40](#)

Bluetooth [19](#)

Bracket [9](#)

Browse

 AIWS [137](#)

 Base Stations [56](#), [73](#), [174](#), [194](#)

Building Layout [40](#)

C

C7 S10 [40](#)

Call list [19](#)

CAP [19](#)

Chargers

 Advanced Charger [7](#), [27](#)

 Basic Charger [7](#), [27](#)

 Battery Charger [7](#), [27](#)

 Rack Charger [7](#), [27](#)

Class 2 [9](#)

Column Mounting [80](#)

Cover

 Remove [134](#)

 Replacing [153](#)

Coverage [37](#)

Coverage pattern [9](#)

Create User Entries [206](#)

CS IP Address [184](#)

CS Port [184](#)

D

Date and Time [155](#)

DECT [7](#)

DECT Info [40](#)

DECT phones [19](#)

DECT R4.zip [45](#)

Default Language [181](#)

default the base station [55](#)

Device Manager [117](#), [128](#)

 AIWS [117](#)

 WinPDM [117](#)

Device Overview [200](#)

Directional Dual Aerial [15](#)

Directional Single Antenna [15](#)

Directory Integration [7](#), [189](#)

Disable Subscription [211](#)

Display Name [206](#)

E

Edit Templates [123](#)

Enable Supplementary Services [183](#)

Index

Error rate [40](#)
External aerials [9](#)

F

Factory reset [34](#)
Fire Doors [37](#)
Firmware [45](#), [60](#)
 Upgrade Base Station [60](#), [75](#), [175](#), [195](#)
Fix Message Center No [183](#)
Frequency [181](#)

G

GAP [19](#)

H

Handover [38](#)
Handset configuration [28](#)
Hands free [19](#)
Host Name [155](#)

I

Idle-Reset [190](#)
IEEE 802.3af [9](#)
Installation
 AIWS [132](#)
Internal aerials [9](#)
IP44 [19](#)
IP Address
 AIWS [155](#)
 Base Station IP Address [57](#), [74](#), [177](#), [197](#)
IPBS [7](#)
IP DECT Base Station [7](#)
IPDI [206](#)
IPEI [206](#)
IP LAN [7](#)
IP Office
 Directory Integration [189](#)
IP Office Release [7](#)

L

Language [181](#)
Languages [19](#)
LAN sockets [7](#)
LED Indication [77](#), [198](#)
Local Port [184](#)
Login [211](#)
Long Name [206](#)
Loudspeaker [19](#)

M

Master base station [9](#)
Master Base Station [181](#)
 Configuration [171](#)
Master IP Address [77](#), [185](#), [198](#)
Mirroring [98](#)
Mounting
 AIWS [152](#)
 Base Station [80](#)

N

Name
 Display [206](#)
 Long [206](#)
New [9](#)
NTP Time Server [155](#)
Number [206](#)
Number of base stations [35](#)
Number of Calls [9](#)

O

Omni-Directional [15](#)
Overlap [35](#)

P

PARI [40](#), [70](#), [186](#)
Pari, Radio, RFP [69](#), [186](#)
Park [40](#)
PARK [187](#)
Password [181](#)
PBX [183](#)
PDM [117](#)
Phone
 Edit template [123](#)
 Login [211](#)
 Software upgrade [90](#)
 Subscription [203](#)
 Template Files [122](#)
Phonebook Properties [155](#)
Phones [19](#)
Phone Subscription [208](#)
Phone Templates
 Upload [120](#)
Pillar Mounting [80](#)
PoE [9](#)
Portable Device Manager [117](#)
Power over Ethernet [9](#)
Protocol [183](#)

Q

Q2 Error rate [40](#)

QoS	181	Switching Off	
R		AIWS	152
Rack Chargers	37	Switch Resilience	98
Radio coverage	9	synchronized	39
Range	37	Sync Mode	77 , 198
Removing the AIWS Cover	134	System Name	181
Replacing the AIWS Cover	153	T	
Reset	190	Technical Bulletin	163
Base Station	190 , 200	Technical Bulletins	45
reset switch	55	Technical Tips	45
Reset Switch	34	Template	122
Resilience	98	Edit	123
Restart	34	TFTP	155
Roaming	38	Time	
RTC Battery	136	Base Station Time Source	180
S		Speech	19
S10	40	Standby	19
SARI	187	Time Server IP Address	155
SCN Backup Options	103	ToS	181
Screened Rooms	37	U	
Separated Locations	39	Unpack the software	45
Setup Wizard	155	Upgrade	
Simultaneous calls	9	AIWS Firmware	163
Site Survey	35	Base Station Firmware	60 , 75 , 175 , 195
Site Survey Mode	40	Phone Software	90
Slave Mode	77 , 198	upgraded	60
SMS	7 , 19	Upload	
SMS messaging	28	Phone templates	120
Software	45	USB	7 , 27
Upgrade Base Station	60 , 75 , 175 , 195	V	
Software upgrades	28	Vibrator	19
Speech Time	19	VLAN	58 , 178
ss	40	W	
Stair Wells	37	Wall Mount	
Standby Time	19	AIWS	152
Starting		Wall Mounting	80
AIWS Device Manager	117	Windows Device Manager	128
Windows Device Manager	128	Windows Portable Device Manager	117
Status Lamp		WinPDM	117
AIWS	30	Wireless	
Status Lamps		Handset configuration	28
Base Station	14	Software Upgrade	28
Subnet Mask	155	With System AC	84 , 181 , 204
Subscription		With User AC	84 , 204
Allow	84 , 204		
Disable	211		
Login	211		
Phone	208		
Phone Subscription	203		
Subscriptions	181		
Supplementary Services	183		
Supported firmware	45		
Supports Fallback	103		