



# **Avaya Oceana<sup>®</sup> Solution Description**

Release 3.8.1  
Issue 4  
January 2022

## Notice

While reasonable efforts have been made to ensure that the information in this document is complete and accurate at the time of printing, Avaya assumes no liability for any errors. Avaya reserves the right to make changes and corrections to the information in this document without the obligation to notify any person or organization of such changes.

## Documentation disclaimer

"Documentation" means information published in varying mediums which may include product information, operating instructions and performance specifications that are generally made available to users of products. Documentation does not include marketing materials. Avaya shall not be responsible for any modifications, additions, or deletions to the original published version of Documentation unless such modifications, additions, or deletions were performed by or on the express behalf of Avaya. End User agrees to indemnify and hold harmless Avaya, Avaya's agents, servants and employees against all claims, lawsuits, demands and judgments arising out of, or in connection with, subsequent modifications, additions or deletions to this documentation, to the extent made by End User.

## Link disclaimer

Avaya is not responsible for the contents or reliability of any linked websites referenced within this site or Documentation provided by Avaya. Avaya is not responsible for the accuracy of any information, statement or content provided on these sites and does not necessarily endorse the products, services, or information described or offered within them. Avaya does not guarantee that these links will work all the time and has no control over the availability of the linked pages.

## Warranty

Avaya provides a limited warranty on Avaya hardware and software. Refer to your sales agreement to establish the terms of the limited warranty. In addition, Avaya's standard warranty language, as well as information regarding support for this product while under warranty is available to Avaya customers and other parties through the Avaya Support website: <https://support.avaya.com/helpcenter/getGenericDetails?detailId=C20091120112456651010> under the link "Warranty & Product Lifecycle" or such successor site as designated by Avaya. Please note that if You acquired the product(s) from an authorized Avaya Channel Partner outside of the United States and Canada, the warranty is provided to You by said Avaya Channel Partner and not by Avaya.

"Hosted Service" means an Avaya hosted service subscription that You acquire from either Avaya or an authorized Avaya Channel Partner (as applicable) and which is described further in Hosted SAS or other service description documentation regarding the applicable hosted service. If You purchase a Hosted Service subscription, the foregoing limited warranty may not apply but You may be entitled to support services in connection with the Hosted Service as described further in your service description documents for the applicable Hosted Service. Contact Avaya or Avaya Channel Partner (as applicable) for more information.

## Hosted Service

THE FOLLOWING APPLIES ONLY IF YOU PURCHASE AN AVAYA HOSTED SERVICE SUBSCRIPTION FROM AVAYA OR AN AVAYA CHANNEL PARTNER (AS APPLICABLE), THE TERMS OF USE FOR HOSTED SERVICES ARE AVAILABLE ON THE AVAYA WEBSITE, [HTTPS://SUPPORT.AVAYA.COM/LICENSEINFO](https://support.avaya.com/licenseinfo) UNDER THE LINK "Avaya Terms of Use for Hosted Services" OR SUCH SUCCESSOR SITE AS DESIGNATED BY AVAYA, AND ARE APPLICABLE TO ANYONE WHO ACCESSES OR USES THE HOSTED SERVICE. BY ACCESSING OR USING THE HOSTED SERVICE, OR AUTHORIZING OTHERS TO DO SO, YOU, ON BEHALF OF YOURSELF AND THE ENTITY FOR WHOM YOU ARE DOING SO (HEREINAFTER REFERRED TO INTERCHANGEABLY AS "YOU" AND "END USER"), AGREE TO THE TERMS OF USE. IF YOU ARE ACCEPTING THE TERMS OF USE ON BEHALF A COMPANY OR OTHER LEGAL ENTITY, YOU REPRESENT THAT YOU HAVE THE AUTHORITY TO BIND SUCH ENTITY TO THESE TERMS OF USE. IF YOU DO NOT HAVE SUCH AUTHORITY, OR IF

YOU DO NOT WISH TO ACCEPT THESE TERMS OF USE, YOU MUST NOT ACCESS OR USE THE HOSTED SERVICE OR AUTHORIZE ANYONE TO ACCESS OR USE THE HOSTED SERVICE.

## Licenses

THE SOFTWARE LICENSE TERMS AVAILABLE ON THE AVAYA WEBSITE, [HTTPS://SUPPORT.AVAYA.COM/LICENSEINFO](https://support.avaya.com/licenseinfo), UNDER THE LINK "AVAYA SOFTWARE LICENSE TERMS (Avaya Products)" OR SUCH SUCCESSOR SITE AS DESIGNATED BY AVAYA, ARE APPLICABLE TO ANYONE WHO DOWNLOADS, USES AND/OR INSTALLS AVAYA SOFTWARE, PURCHASED FROM AVAYA INC., ANY AVAYA AFFILIATE, OR AN AVAYA CHANNEL PARTNER (AS APPLICABLE) UNDER A COMMERCIAL AGREEMENT WITH AVAYA OR AN AVAYA CHANNEL PARTNER. UNLESS OTHERWISE AGREED TO BY AVAYA IN WRITING, AVAYA DOES NOT EXTEND THIS LICENSE IF THE SOFTWARE WAS OBTAINED FROM ANYONE OTHER THAN AVAYA, AN AVAYA AFFILIATE OR AN AVAYA CHANNEL PARTNER; AVAYA RESERVES THE RIGHT TO TAKE LEGAL ACTION AGAINST YOU AND ANYONE ELSE USING OR SELLING THE SOFTWARE WITHOUT A LICENSE. BY INSTALLING, DOWNLOADING OR USING THE SOFTWARE, OR AUTHORIZING OTHERS TO DO SO, YOU, ON BEHALF OF YOURSELF AND THE ENTITY FOR WHOM YOU ARE INSTALLING, DOWNLOADING OR USING THE SOFTWARE (HEREINAFTER REFERRED TO INTERCHANGEABLY AS "YOU" AND "END USER"), AGREE TO THESE TERMS AND CONDITIONS AND CREATE A BINDING CONTRACT BETWEEN YOU AND AVAYA INC. OR THE APPLICABLE AVAYA AFFILIATE ("AVAYA").

Avaya grants You a license within the scope of the license types described below, with the exception of Heritage Nortel Software, for which the scope of the license is detailed below. Where the order documentation does not expressly identify a license type, the applicable license will be a Designated System License as set forth below in the Designated System(s) License (DS) section as applicable. The applicable number of licenses and units of capacity for which the license is granted will be one (1), unless a different number of licenses or units of capacity is specified in the documentation or other materials available to You. "Software" means computer programs in object code, provided by Avaya or an Avaya Channel Partner, whether as stand-alone products, pre-installed on hardware products, and any upgrades, updates, patches, bug fixes, or modified versions thereto. "Designated Processor" means a single stand-alone computing device. "Server" means a set of Designated Processors that hosts (physically or virtually) a software application to be accessed by multiple users. "Instance" means a single copy of the Software executing at a particular time: (i) on one physical machine; or (ii) on one deployed software virtual machine ("VM") or similar deployment.

## License types

Designated System(s) License (DS). End User may install and use each copy or an Instance of the Software only: 1) on a number of Designated Processors up to the number indicated in the order; or 2) up to the number of Instances of the Software as indicated in the order, Documentation, or as authorized by Avaya in writing. Avaya may require the Designated Processor(s) to be identified in the order by type, serial number, feature key, Instance, location or other specific designation, or to be provided by End User to Avaya through electronic means established by Avaya specifically for this purpose.

Concurrent User License (CU). End User may install and use the Software on multiple Designated Processors or one or more Servers, so long as only the licensed number of Units are accessing and using the Software at any given time as indicated in the order, Documentation, or as authorized by Avaya in writing. A "Unit" means the unit on which Avaya, at its sole discretion, bases the pricing of its licenses and can be, without limitation, an agent, port or user, an e-mail or voice mail account in the name of a person or corporate function (e.g., webmaster or helpdesk), or a directory entry in the administrative database utilized by the Software that permits one user to interface with the Software. Units may be linked to a specific, identified Server or an Instance of the Software.

## Heritage Nortel Software

"Heritage Nortel Software" means the software that was acquired by Avaya as part of its purchase of the Nortel Enterprise Solutions

Business in December 2009. The Heritage Nortel Software is the software contained within the list of Heritage Nortel Products located at <https://support.avaya.com/LicenseInfo> under the link "Heritage Nortel Products" or such successor site as designated by Avaya. For Heritage Nortel Software, Avaya grants Customer a license to use Heritage Nortel Software provided hereunder solely to the extent of the authorized activation or authorized usage level, solely for the purpose specified in the Documentation, and solely as embedded in, for execution on, or for communication with Avaya equipment. Charges for Heritage Nortel Software may be based on extent of activation or use authorized as specified in an order or invoice.

### Copyright

Except where expressly stated otherwise, no use should be made of materials on this site, the Documentation, Software, Hosted Service, or hardware provided by Avaya. All content on this site, the documentation, Hosted Service, and the product provided by Avaya including the selection, arrangement and design of the content is owned either by Avaya or its licensors and is protected by copyright and other intellectual property laws including the sui generis rights relating to the protection of databases. You may not modify, copy, reproduce, republish, upload, post, transmit or distribute in any way any content, in whole or in part, including any code and software unless expressly authorized by Avaya. Unauthorized reproduction, transmission, dissemination, storage, and or use without the express written consent of Avaya can be a criminal, as well as a civil offense under the applicable law.

### Virtualization

The following applies if the product is deployed on a virtual machine. Each product has its own ordering code and license types. Unless otherwise stated, each Instance of a product must be separately licensed and ordered. For example, if the end user customer or Avaya Channel Partner would like to install two Instances of the same type of products, then two products of that type must be ordered.

### Third Party Components

"Third Party Components" mean certain software programs or portions thereof included in the Software or Hosted Service may contain software (including open source software) distributed under third party agreements ("Third Party Components"), which contain terms regarding the rights to use certain portions of the Software ("Third Party Terms"). As required, information regarding distributed Linux OS source code (for those products that have distributed Linux OS source code) and identifying the copyright holders of the Third Party Components and the Third Party Terms that apply is available in the products, Documentation or on Avaya's website at: <https://support.avaya.com/Copyright> or such successor site as designated by Avaya. The open source software license terms provided as Third Party Terms are consistent with the license rights granted in these Software License Terms, and may contain additional rights benefiting You, such as modification and distribution of the open source software. The Third Party Terms shall take precedence over these Software License Terms, solely with respect to the applicable Third Party Components to the extent that these Software License Terms impose greater restrictions on You than the applicable Third Party Terms.

The following applies only if the H.264 (AVC) codec is distributed with the product. THIS PRODUCT IS LICENSED UNDER THE AVC PATENT PORTFOLIO LICENSE FOR THE PERSONAL USE OF A CONSUMER OR OTHER USES IN WHICH IT DOES NOT RECEIVE REMUNERATION TO (i) ENCODE VIDEO IN COMPLIANCE WITH THE AVC STANDARD ("AVC VIDEO") AND/OR (ii) DECODE AVC VIDEO THAT WAS ENCODED BY A CONSUMER ENGAGED IN A PERSONAL ACTIVITY AND/OR WAS OBTAINED FROM A VIDEO PROVIDER LICENSED TO PROVIDE AVC VIDEO. NO LICENSE IS GRANTED OR SHALL BE IMPLIED FOR ANY OTHER USE. ADDITIONAL INFORMATION MAY BE OBTAINED FROM MPEG LA, L.L.C. SEE <HTTP://WWW.MPEGLA.COM>.

### Service Provider

THE FOLLOWING APPLIES TO AVAYA CHANNEL PARTNER'S HOSTING OF AVAYA PRODUCTS OR SERVICES. THE PRODUCT OR HOSTED SERVICE MAY USE THIRD PARTY COMPONENTS SUBJECT TO THIRD PARTY TERMS AND REQUIRE A SERVICE PROVIDER TO BE INDEPENDENTLY LICENSED DIRECTLY FROM THE THIRD PARTY SUPPLIER. AN AVAYA CHANNEL PARTNER'S

HOSTING OF AVAYA PRODUCTS MUST BE AUTHORIZED IN WRITING BY AVAYA AND IF THOSE HOSTED PRODUCTS USE OR EMBED CERTAIN THIRD PARTY SOFTWARE, INCLUDING BUT NOT LIMITED TO MICROSOFT SOFTWARE OR CODECS, THE AVAYA CHANNEL PARTNER IS REQUIRED TO INDEPENDENTLY OBTAIN ANY APPLICABLE LICENSE AGREEMENTS, AT THE AVAYA CHANNEL PARTNER'S EXPENSE, DIRECTLY FROM THE APPLICABLE THIRD PARTY SUPPLIER.

WITH RESPECT TO CODECS, IF THE AVAYA CHANNEL PARTNER IS HOSTING ANY PRODUCTS THAT USE OR EMBED THE H.264 CODEC OR H.265 CODEC, THE AVAYA CHANNEL PARTNER ACKNOWLEDGES AND AGREES THE AVAYA CHANNEL PARTNER IS RESPONSIBLE FOR ANY AND ALL RELATED FEES AND/OR ROYALTIES. THE H.264 (AVC) CODEC IS LICENSED UNDER THE AVC PATENT PORTFOLIO LICENSE FOR THE PERSONAL USE OF A CONSUMER OR OTHER USES IN WHICH IT DOES NOT RECEIVE REMUNERATION TO: (I) ENCODE VIDEO IN COMPLIANCE WITH THE AVC STANDARD ("AVC VIDEO") AND/OR (II) DECODE AVC VIDEO THAT WAS ENCODED BY A CONSUMER ENGAGED IN A PERSONAL ACTIVITY AND/OR WAS OBTAINED FROM A VIDEO PROVIDER LICENSED TO PROVIDE AVC VIDEO. NO LICENSE IS GRANTED OR SHALL BE IMPLIED FOR ANY OTHER USE. ADDITIONAL INFORMATION FOR H.264 (AVC) AND H.265 (HEVC) CODECS MAY BE OBTAINED FROM MPEG LA, L.L.C. SEE <HTTP://WWW.MPEGLA.COM>.

### Compliance with Laws

You acknowledge and agree that it is Your responsibility for complying with any applicable laws and regulations, including, but not limited to laws and regulations related to call recording, data privacy, intellectual property, trade secret, fraud, and music performance rights, in the country or territory where the Avaya product is used.

### Preventing Toll Fraud

"Toll Fraud" is the unauthorized use of your telecommunications system by an unauthorized party (for example, a person who is not a corporate employee, agent, subcontractor, or is not working on your company's behalf). Be aware that there can be a risk of Toll Fraud associated with your system and that, if Toll Fraud occurs, it can result in substantial additional charges for your telecommunications services.

### Avaya Toll Fraud intervention

If You suspect that You are being victimized by Toll Fraud and You need technical assistance or support, call Technical Service Center Toll Fraud Intervention Hotline at +1-800-643-2353 for the United States and Canada. For additional support telephone numbers, see the Avaya Support website: <https://support.avaya.com> or such successor site as designated by Avaya.

### Security Vulnerabilities

Information about Avaya's security support policies can be found in the Security Policies and Support section of <https://support.avaya.com/security>.

Suspected Avaya product security vulnerabilities are handled per the Avaya Product Security Support Flow (<https://support.avaya.com/css/P8/documents/100161515>).

### Downloading Documentation

For the most current versions of Documentation, see the Avaya Support website: <https://support.avaya.com>, or such successor site as designated by Avaya.

### Contact Avaya Support

See the Avaya Support website: <https://support.avaya.com> for product or Hosted Service notices and articles, or to report a problem with your Avaya product or Hosted Service. For a list of support telephone numbers and contact addresses, go to the Avaya Support website: <https://support.avaya.com> (or such successor site as designated by Avaya), scroll to the bottom of the page, and select Contact Avaya Support.

### Trademarks

The trademarks, logos and service marks ("Marks") displayed in this site, the Documentation, Hosted Service(s), and product(s) provided by Avaya are the registered or unregistered Marks of Avaya, its

affiliates, its licensors, its suppliers, or other third parties. Users are not permitted to use such Marks without prior written consent from Avaya or such third party which may own the Mark. Nothing contained in this site, the Documentation, Hosted Service(s) and product(s) should be construed as granting, by implication, estoppel, or otherwise, any license or right in and to the Marks without the express written permission of Avaya or the applicable third party.

Avaya is a registered trademark of Avaya Inc.

# AVAYA

All non-Avaya trademarks are the property of their respective owners.

Java is a registered trademark of Oracle and/or its affiliates.



# Contents

<b>Chapter 1: Introduction</b> .....	10
Purpose.....	10
Change history.....	10
New in this release.....	10
Support for multiple Hunt Groups.....	10
New online help for OCP application.....	11
Support for Cross Channel Queue Limits.....	11
Support for Delivery Failure Notification.....	11
Support for Credit Card Redaction.....	11
Support for routing enhancement - contact priority.....	11
Support for Conversation Transcripts through Email.....	11
Support for EU Data Center deployments.....	12
Authorization added to ContextStoreScreenPop.....	12
Context Store Schema Creation scripts for Postgres and SQL.....	12
Gigaspaces upgrade.....	12
Support for Inbound MMS.....	13
Support for integration of Avaya Workspaces for Avaya Oceana® and Avaya Workplace Client.....	13
Support for approval of outbound emails.....	14
Support for integrating social messaging platforms with Avaya Oceana®.....	14
Support for enhancement of timed After Contact Work.....	14
Support for OAuth for Avaya Oceana® email - Office 365.....	14
Support for upscaling Avaya Analytics™ cluster.....	14
Support for Avaya Analytics™ full database backup on remote server.....	15
Support for reset Historical Reporting local users password.....	15
Support to view or delete Historical Reporting local users.....	15
Support for Private key storage.....	15
Support for VMware ESXi 7.0.....	15
Support for Avaya Analytics™ Disaster Recovery Monitoring Tool for replication and failovers.....	16
Enhancement in deployment spreadsheet.....	16
Support for upgrading to Avaya Analytics™ Release 4.1.1.0.....	16
Support for Avaya Analytics™ migration from Release 3.7.0.2 to Release 4.1.1.0.....	16
Support for Routing Service Groups in Avaya Analytics™ Historical Reporting.....	16
Support for Call Profile reports in Avaya Analytics™.....	17
Support for EASG-based Authentication in Avaya Oceana® and Avaya Analytics™.....	17
Support for CSV file enhancement for WFO integration.....	17
Support for authentication between outbound connector and Omnichannel resource connector.....	17
Support for Omnichannel Database Server identity certificate expiry alarms.....	18

Support for Oceana Breeze Node Identity certificate expiry alarms.....	18
<b>Chapter 2: Overview</b> .....	19
Avaya Oceana® overview.....	19
Avaya Workspaces for Avaya Oceana® overview.....	20
Avaya Analytics™ for Avaya Oceana® overview.....	22
Avaya Common Services overview.....	23
<b>Chapter 3: Architecture</b> .....	25
Avaya Oceana® architecture.....	25
Avaya Oceana® components.....	27
Avaya Control Manager overview.....	28
Avaya Breeze® platform overview.....	30
Avaya Oceana® Clusters overview.....	31
Avaya Aura® components.....	33
Voice Self Service overview.....	34
Outbound overview.....	34
Web Voice and Web Video overview.....	34
Avaya Engagement Designer for workflow design support.....	35
Work Assignment overview.....	36
Work Assignment features.....	36
Avaya Workspaces for Avaya Oceana® architecture.....	46
Avaya Workspaces for Avaya Oceana® components.....	47
Avaya Analytics™ for Avaya Oceana® architecture.....	48
Avaya Analytics™ for Avaya Oceana® components.....	49
<b>Chapter 4: Interoperability</b> .....	50
Components.....	50
Accessing the Compatibility Matrix.....	53
<b>Chapter 5: Features</b> .....	54
Avaya Oceana® features.....	54
Attribute-based routing.....	54
Authorized access to Avaya Oceana® transcripts.....	55
Automated migration process.....	55
Avaya Aura® Web Gateway support.....	55
Avaya Workforce Engagement Select integration .....	55
Callback Assist.....	56
Centralized logging.....	57
Channel exclusivity.....	58
Data access groups.....	58
Data redundancy and disaster recovery.....	59
Defer email.....	60
Deployment modes.....	61
Export and import of multiple workflows.....	61
External transcript access.....	61
High availability and cache mirroring.....	62

Integration of Avaya Workforce Engagement Select with Avaya Oceana® .....	65
Integration of Watson adapter for custom chatbot.....	65
Customer Journey and visualization.....	65
Messaging channel.....	67
Multichannel support.....	67
Oceana Data Viewer.....	70
Post Call Survey.....	70
Remote workers.....	72
Second Chance Interactive Voice Response.....	73
SNMP alarming.....	75
Avaya CRMGateway snap-in support.....	76
Customer accounts management.....	76
Browser close and network connection issues.....	78
Last Agent Routing.....	79
Last Email Routing.....	79
Service level configuration and reporting.....	79
Virtualization.....	80
Web technologies supported.....	85
Authentication between outbound connector and omnichannel resource connector.....	85
OAuth for Avaya Oceana® and Avaya Analytics™ Email for Office 365.....	86
Supported Agent Transfer and Conference scenarios for voice calls.....	86
Supported Agent Forward, Transfer, and Conference scenarios for digital contacts.....	86
Avaya Workspaces features.....	88
Web browser-based access.....	88
Modern and responsive design.....	88
Single interface for all contact center applications.....	89
Real-time reporting through Supervisor reporting dashboard.....	89
User management for Supervisor reporting dashboard.....	91
Assigning thresholds for views and measures.....	92
Canned real-time dashboards and views in Avaya Workspaces.....	92
Blended agents.....	93
Extensibility.....	93
Web browsers supported.....	94
Customization of transfer to service list.....	94
Workflow design.....	94
Address book support for LDAP.....	95
Start work button behavior.....	95
Single sign-on in Avaya Workspaces.....	95
Endpoint support for voice calls using Avaya Workspaces.....	96
Receive interactions.....	96
Hold or resume interactions.....	96
Auto answering.....	97
Consult agents.....	97

Supported transfer operations.....	97
Addition of another agent to the interaction.....	98
Recording of work codes for reporting.....	98
Customer Journey.....	98
Co-browse support.....	98
Screenpops.....	99
Timed after contact work.....	99
Customer history search.....	100
Address book.....	100
Disposition codes.....	100
Defer email.....	101
Agent monitoring.....	101
Observe.....	101
Barge.....	102
Agent state change.....	102
Transfer and conference of PSTN and Web voice calls.....	102
Outbound email approval process.....	103
Integration of Avaya Workspaces for Avaya Oceana® and Avaya Workplace Client.....	103
Social messaging platforms.....	104
Avaya Analytics™ features.....	105
Historical reporting.....	105
Call Profile reports.....	105
Real-time reporting.....	106
Assigning thresholds for views and measures.....	106
Canned historical dashboards and reports in Avaya Analytics™.....	106
Canned real-time dashboards and views in Avaya Workspaces.....	110
Full database backup on a remote server.....	111
Upscaling Avaya Analytics™ overview.....	111
Avaya Analytics™ DR monitoring tool.....	112
Enhanced CSV file for WFO integration.....	112
<b>Chapter 6: Capacity specifications.....</b>	<b>114</b>
Omnichannel database customer contact ratio.....	119
<b>Chapter 7: Avaya Oceana® Specifications.....</b>	<b>120</b>
Hardware and software specifications.....	120
Avaya Oceana® hardware requirements.....	124
Avaya Workspaces for Avaya Oceana® specifications.....	130
Avaya Analytics™ hardware requirements for High Availability deployment.....	130
Thin provisioning of disk storage in VMware.....	134
Avaya Analytics™ hardware requirements for non-High Availability deployment.....	134
Upgrade and migration paths.....	135
<b>Chapter 8: Security.....</b>	<b>137</b>
Security considerations.....	137
SAL Policy Manager.....	138

- EASG-based authentication in Avaya Oceana® and Avaya Analytics™ ..... 138
- Transport layer security..... 138
- Secure communication using SSL..... 139
- Data privacy support..... 139
  - SocialConnector..... 139
  - ZangSmsConnector..... 140
  - Co-Browsing Snap-in..... 140
- Guidelines for the use of antivirus software..... 141
- Avaya Oceana® Omnichannel Microsoft Windows Server 2016 antivirus software..... 142
- Chapter 9: Licensing requirements**..... 143
  - Infrastructure system package..... 143
  - Product licensing and delivery system..... 143
  - Avaya Workspaces for Avaya Oceana® licensing..... 143
  - WebLM..... 144
  - Upgrade Advantage Preferred..... 144
- Chapter 10: Resources**..... 145
  - Documentation..... 145
    - Finding documents on the Avaya Support website..... 146
    - Avaya Documentation Center navigation..... 147
  - Training..... 148
  - Support..... 151

# Chapter 1: Introduction

---

## Purpose

This document describes Avaya Oceana® from a holistic perspective focusing on the strategic, enterprise, and functional views of the architecture. It also includes a high-level description of each verified reference configuration for the solution.

Use the document if you want to understand how Avaya Oceana® and related products work together in verified reference configurations to meet customer needs.

---

## Change history

Issue	Date	Summary of changes
4	Jan 2022	Updated the section “Gigaspaces upgrade”.
3	Nov 2021	Minor updates throughout the document.
2	April 2021	Updated the following: <ul style="list-style-type: none"><li>• “Supported browsers” section.</li><li>• “Avaya Workspaces for Avaya Oceana® specifications” section.</li><li>• Minor updates.</li></ul>
1	April 2021	Initial issue for Avaya Oceana® Release 3.8.1.

---

## New in this release

Avaya Oceana® Release 3.8.1 includes the following features and enhancements:

---

### Support for multiple Hunt Groups

Avaya Oceana® voice channel fallback design supports multiple Hunt Groups, with each Hunt Group configured as a fallback for one or more agent categories.

---

## New online help for OCP application

The Omnichannel Administration Utility now has an integrated online help for each feature. This allows the user to access help from the OCP application.

---

## Support for Cross Channel Queue Limits

Avaya Oceana® introduces cross-channel queue limits to prevent the system failure due to large number of queued contacts. The limits in Avaya Oceana® have been channel based and not an overall limit on the number of contacts. These channel specific limits are still applicable, but Avaya Oceana® introduces an overall limit on the contacts that can be present in the system queue and rejects all new digital contacts when cross-channel limit is reached.

---

## Support for Delivery Failure Notification

Avaya Oceana® may undergo outages or maintenance windows longer than 15 minutes. The users who message the contact center during an outage period may be unaware that the message has not been delivered to the Contact Center. Avaya Oceana® introduces the Delivery Failure Notification feature providing automatic configurable notification to the users that the message has not been processed and to retry again later. The users are also notified that the messages sent to the Contact Center are not processed if Avaya Oceana® has reached the maximum capacity.

---

## Support for Credit Card Redaction

Avaya Oceana® introduces the Credit Card Redaction feature which allows credit card patterns sent by the user in a message to be redacted, and not shared with the agent, or stored in the transcript.

---

## Support for routing enhancement - contact priority

Avaya Oceana® introduces custom routing attribute using which Contact Priority (1-10) can be set for the web messenger.

---

## Support for Conversation Transcripts through Email

Avaya Oceana® introduces sending Conversation Transcripts through Email feature that allows web messenger users to get the transcript of the conversation through email after the session.

---

## Support for EU Data Center deployments

Avaya Oceana® introduces EU Data Center deployments feature that allows the user to determine at installation time if the AWS instance used is US data center or EU Data Center.

---

## Authorization added to ContextStoreScreenPop

Authorization support is now available for the ContextStoreScreenPop Service. It is disabled as default. This is to ensure the service is working when authentication is enabled for ContextStoreRest. If authorization is enabled for ContextStoreRest, then you must provide a token to ContextStoreScreenPop for its POST/PUT APIs.

---

## Context Store Schema Creation scripts for Postgres and SQL

For new customers, the ContextStoreSchemaCreation scripts are upgraded for both Postgres and SQL Databases. For more information, see <https://support.avaya.com>.

For existing customers with 3.8.x EDM schema, it is required to execute the following scripts:

- For Postgres - ALTER TABLE GENERATED\_KEYS ALTER COLUMN VALUE\_COLUMN TYPE INT8;
- For SQLServer - ALTER TABLE GENERATED\_KEYS ALTER COLUMN VALUE\_COLUMN NUMERIC(19,0);

---

## Gigaspaces upgrade

The Gigaspaces component is upgraded to Release 15.8. from Gigaspaces Release 10.2. Because of this upgrade, key Context Store services are upgraded to use Gigaspaces 15.8. Hence, there are changes in the following ContextStoreManager DataGrid sizing parameters:

- Values without measure units are now considered as megabytes.
- Megabytes can be specified with an `m` or `mb` after the number. For example, `1024m`.
- GB can be specified with a `g` after the number. For example, `1g`.
- Third parameter is not required for datagrid sizes.

To achieve the same deployment settings as in GS10.2, you must modify datagrid related settings. For example,

"ContextStore ManagerSpace DataGrid Settings" '1,2,1' => '1g, 2g'

"ContextStoreSpace DataGrid Settings" '512m,10240m,1' => '512m, 10240m'

"EDM: Mirror Service container size" '1' => '1g'

"GEO: Gateway Service container size" '2' => '2g'

---

## Support for Inbound MMS

Avaya Oceana® supports inbound MMS with the following features:

**\* Note:**

Avaya Oceana® supports only inbound MMS, not media transfer from agents to users.

- Media is included as link in Avaya Oceana® from CPaaS.
- CPaaS media links is accessible only for six months.
- Agents require Internet access to access CPaaS MMS link.
- In Customer journey and history, user experience is logged as SMS channel only.
- CPaaS does not perform antivirus scanning for MMS. Users must perform this scan.
- MMS and SMS must be enabled for **Phone Number** that is configured in CPaaS.
- The same inbound URL is configured for SMS and MMS in the CPaaS account.
- The Media size limit is 750 KB.
- The following Media types are supported:
  - **Audio:** AMR, MP3, WAVE
  - **Image:** JPEG, GIF, PNG
  - **Video:** MP4
- MMS CPaaS supports a maximum text length of 160 characters.

**\* Note:**

Avaya Oceana® does not support Inbound MMS in **Breeze** mode.

---

## Support for integration of Avaya Workspaces for Avaya Oceana® and Avaya Workplace Client

As a SIP-based Avaya Aura Unified Communications endpoint, you can deploy Avaya Workplace Client for all Avaya Oceana® and Avaya Analytics™ registered users. Avaya Oceana® users can use Avaya Workplace Client as a softphone with Avaya Workspaces for handling Oceana® routed and non-Oceana® routed voice contacts. Additionally, customers can now deploy remote Avaya Oceana® users (Supervisors and agents) on the Internet using Avaya Workplace Client as the Avaya Aura Unified Communications endpoint for Oceana® routed voice contacts and direct non-Oceana® routed voice contacts.

Avaya Analytics™ generates reports on Avaya Oceana® with the Avaya Workplace Client in the same manner as non-Avaya Workplace Client users.

---

## Support for approval of outbound emails

Avaya Oceana<sup>®</sup> introduces support for approval of outbound agent email replies. For customer satisfaction and to avoid escalations, an agent's email responses can now be routed through an approval process.

Avaya Analytics<sup>™</sup> supports the ability to generate custom reports on the approval or rejection of the outbound emails for both real-time and historical operations.

---

## Support for integrating social messaging platforms with Avaya Oceana<sup>®</sup>

You can integrate social messaging platforms with Avaya Oceana<sup>®</sup> through the Avaya Digital Connection. The Avaya Digital Connection is a software platform that enables businesses to communicate with their customers across several popular messaging apps.

Avaya Oceana<sup>®</sup> supports messaging with the following social platforms:

- WhatsApp
- Facebook Messenger
- Twitter Direct Message

---

## Support for enhancement of timed After Contact Work

Avaya Oceana<sup>®</sup> introduces support for enhancement of timed after contact work by allowing a system administrator to configure After Contact Work (ACW) timer values on a per-service and per-channel basis.

---

## Support for OAuth for Avaya Oceana<sup>®</sup> email - Office 365

Avaya Oceana<sup>®</sup> supports OAuth to allow our customers to continue to operate their email channels after Microsoft announced the end of support for basic authentication of POP3 and IMAP in Office 365.

---

## Support for upscaling Avaya Analytics<sup>™</sup> cluster

Avaya Analytics<sup>™</sup> supports upscaling the cluster by accommodating the changes in the existing configuration. The upscaling process involves increasing the VMware node resources for the Avaya Common Services cluster by allocating additional CPU, memory, and disk storage.

---

## Support for Avaya Analytics™ full database backup on remote server

You can schedule to run an automatic full backup of the Avaya Analytics™ historical reporting database to a remote server, which is located outside of the cluster. You can also run an immediate full backup manually.

---

## Support for reset Historical Reporting local users password

Avaya Analytics™ 4.1.1.0 introduces the ability for users to reset their login password in one of two ways:

- The Supervisor and Administrator reporting user can reset their own password once they have logged into Avaya Analytics™.
- The Historical Reporting administrator can use the Analytics Administration script on the Cluster Control Manager (CCM) to reset the password of Historical Reporting local users (including supervisors) accounts.

---

## Support to view or delete Historical Reporting local users

The Historical Reporting administrator can use the Analytics Administration script on the Cluster Control Manager (CCM) to view the list and delete Historical Reporting local user accounts.

---

## Support for Private key storage

You must input a password for encrypting the key during the CSR file creation and input that same password during the importing procedure of the certificate.

The private key is displayed in an encrypted format on Cluster Control Manager (CCM).

---

## Support for VMware ESXi 7.0

Avaya Oceana® 3.8.1 and Avaya Analytics™ 4.1.1 supports the following VMware versions:

- VMware ESXi 6.5, 6.7, and 7.0
- Citrix/Xenapp 7.6

---

## Support for Avaya Analytics™ Disaster Recovery Monitoring Tool for replication and failovers

Avaya Analytics™ offers DR monitoring tool that allows you to understand the current status of your replication environment between the active and standby.

---

## Enhancement in deployment spreadsheet

You can see the status of the Macros as `enabled` or `disabled` on the Instructions worksheet of the deployment spreadsheet.

If the macros are disabled, then other worksheets are not visible. Therefore you must enable the macros to proceed.

---

## Support for upgrading to Avaya Analytics™ Release 4.1.1.0

You can use online and offline modes to upgrade Avaya Analytics™. You can archive, export, and save custom reports during an upgrade. Avaya Analytics™ 4.1.1.0 release supports the following upgrade paths:

- Avaya Analytics™ 4.0.0.1 Patch 7 to Avaya Analytics™ 4.1.1.0
- Avaya Analytics™ 4.1.0.0 Patch 1 to Avaya Analytics™ 4.1.1.0
- Avaya Analytics™ 4.1.0.1 to Avaya Analytics™ 4.1.1.0

 **Note:**

You can upgrade the Avaya Analytics™ component before upgrading the Avaya Oceana® component.

---

## Support for Avaya Analytics™ migration from Release 3.7.0.2 to Release 4.1.1.0

Avaya Analytics™ supports data migration, data retention, and legacy data roll up from Release 3.7.0.2 to Release 4.1.1.0.

---

## Support for Routing Service Groups in Avaya Analytics™ Historical Reporting

You can configure Routing Service Groups for Historical Reporting in Avaya Analytics™. You can select the routing services within a routing service group for reporting and track the historical

performance of the channel. You can only view routing services and routing service measures associated with the routing service group to which you are assigned.

---

## Support for Call Profile reports in Avaya Analytics™

You can use the Call Profile historical reporting feature in Avaya Analytics™ to view information about the call performance of your routing services for a selected duration. You can view this information for the routing services in the Routing Service Groups to which you are assigned.

Call Profile reports display information such as whether a call was answered, the duration of a call, the duration for which a call was waiting in a queue, or whether a call was abandoned. The following Call Profile reports are available in Avaya Analytics™:

- Call Profile Abandoned
- Call Profile Active Time Duration
- Call Profile Answered
- Call Profile Waiting in Queue

---

## Support for EASG-based Authentication in Avaya Oceana® and Avaya Analytics™

Avaya Oceana® and Avaya Analytics™ provide support for Enhanced Access Security Gateway (EASG) based authentication. Using a challenge-response mechanism, EASG allows support engineers and remote users to log in to the Web administrative interfaces of Avaya Oceana® and Avaya Analytics™, without using credentials such as username and password.

---

## Support for CSV file enhancement for WFO integration

You can configure Avaya Analytics™ to generate CSV files for Agent By Account and Routing Service historical reports. For the Agent by Account historical report, you can enable daily or interval CSV Producers. For the Routing Service historical report, you can enable only Interval CSV Producers.

---

## Support for authentication between outbound connector and Omnichannel resource connector

Avaya Oceana® introduces support for establishing authentication between the outbound connector and the Omnichannel resource connector for system security.

---

## **Support for Omnichannel Database Server identity certificate expiry alarms**

Avaya Oceana® raises an alarm 60 days before the Omnichannel database server identity certificates are due to expire. This alarm is visible in the Avaya Aura® System Manager event viewer.

---

## **Support for Oceana Breeze Node Identity certificate expiry alarms**

Avaya Breeze® nodes in an Avaya Oceana® solution can be integrated with Avaya Aura® System Manager SNMP listener service to capture all KeyStore identity certificates expiry alarms. The alarms are captured from 60 days to the expiry date and displayed in the event viewer in System Manager. If System Manager is configured with access to a network management application or a simple mail server mailbox, these alarms can be forwarded to an authorized system administrator.

# Chapter 2: Overview

---

## Avaya Oceana<sup>®</sup> overview

Avaya Oceana<sup>®</sup> is the next-generation customer engagement solution. Enterprises can use Avaya Oceana<sup>®</sup> to seamlessly handle Generic, Voice, Web and Mobile Chat, Web Voice, Web Video, Email, Simple Messaging, Social Media, WebRTC, Video, POM contacts, and Messaging channels using a single intelligent attribute-based call routing through a unified Agent Desktop. Avaya Oceana<sup>®</sup> is built on the Avaya Breeze<sup>®</sup> platform using modular snap-ins that can be independently scaled, managed, and extended.

You can merge existing resources into routing strategies of Avaya Oceana<sup>®</sup> to significantly improve customer service and sales outcomes.

With these routing strategies, you can:

- Obtain customer information from Customer Relationship Management (CRM) of the enterprises and other third-party systems.
- Combine the information with the current journey context of the customer.
- Apply business goals-oriented strategies to match the customer to the best available resource.

The routing strategies also integrate with the back-office systems of enterprises to route work items such as claims and contracts.

Avaya Oceana<sup>®</sup> provides:

- Functionality to map the customer journey across various self-service and assisted service channels by storing the related data crumbs in the in-memory data grid. Resources and routing workflows use these data crumbs.
- An easy-to-use HTML5-based Desktop for agents and supervisors.
- Reporting and analytics designed to provide new and powerful insights for blended agent contact centers.

Avaya Oceana<sup>®</sup> consists of the following:

- Access tier: Provides media-specific providers such as Chat Provider, Email Provider, Avaya Aura<sup>®</sup> Communication Manager for Voice, and Avaya Mobile Communication Snap-in for Web Voice and Web Video.
- Normalizing tier: Provides a central normalizing tier within Avaya Oceana<sup>®</sup> that abstracts the media-specific characteristics of the inbound interactions.

- Application tier: Provides applications such as agent and supervisor desktops and Avaya Engagement Designer. Business analysts use these applications to author the logic that handles the inbound interactions such as routing and reporting. They also use the applications for other higher-level functions in a future-proofed contact center product.
- Components tier: Provides Avaya Breeze® platform and a set of core components deployed on Avaya Breeze® platform.

Avaya Aura® and Avaya Breeze® platform application tiers run on the Linux operating system, while Avaya Control Manager and Avaya Omnichannel run on the Microsoft Windows server operating system.

Avaya Oceana® provides the following:

- Load Balancers: Each Avaya Breeze® platform cluster in an Avaya Oceana® includes a load balancer. Therefore, Avaya Oceana® does not require using external load balancers for the Avaya Oceana® features and functions. In Avaya Oceana® with a disaster recovery feature, only one site is active at a time. Do not use a load balancer between the two disaster recovery sites for Avaya Workspaces agents. In a disaster recovery deployment, the Avaya Session Border Controller for Enterprise diverts traffic between site A and site B. Avaya Session Border Controller for Enterprise is also mandatory for media for WebRTC Connect. Agents can connect directly to the active site. Any requirements for including Avaya Oceana® web traffic with an external load balancer requires Avaya Professional Services consulting, outside baseline Avaya Oceana® deployment or support activities.
- Reverse Proxies: Avaya Oceana® supports a properly specified and configured reverse proxy for use with Avaya Workspaces agents. For more information, see *Avaya Oceana® Port Matrix* document.

For information about configuring Avaya Workspaces Widgets when using a reverse proxy, see *Avaya Workspaces Widget Framework* documentation.

Avaya recommends using a reverse proxy with the Avaya Oceana WebChat Reference Frontend. For more information, refer to the *Avaya Oceana Reference Frontend* documentation.

- Firewall: Avaya recommends using properly specified and configured firewall and firewall policies. For more information about supported firewall types and firewall policies, see *Avaya Oceana® Port Matrix* document.

---

## Avaya Workspaces for Avaya Oceana® overview

Avaya Workspaces is a browser-based application through which contact center agents can handle inbound customer interactions. The types of interactions can be Voice, Email, SMS, Chat, Social Media, or Messaging. Agents can also make outbound voice calls and create ad-hoc emails. The intuitive user interface provides features for toggling between multiple, simultaneous interactions through different channels.

Avaya Workspaces enables seamless collaboration with customers, partners, and other users within and outside the organization. With this interface, agents can access the relevant information in a secure and reliable manner.

Every interaction is displayed as an interaction card. Using interaction cards, agents can:

- Receive the interaction: Accept interactions with a single click.
- Hold or resume the voice interaction: Put an active voice interaction on hold when another interaction with a higher priority must be attended.
- Consult another agent: Seek advice about an interaction.
- Transfer the interaction to another agent: Send the interaction to the interaction area of another agent.
- Add another agent to the interaction: Create a conference with another agent when the other agent can contribute to resolving the customer interaction.
- Record work codes for reporting: Select from the configured work codes to report the type of work done during the interaction.
- Record disposition codes for reporting: Select from the configured disposition codes to add disposition to the interaction.
- Defer email interaction using interaction cards.

Avaya Workspaces provides the following major features:

- Customer journey: The system displays a graphical representation of the customer interactions. Every point in the customer journey is visualized by an interaction with a channel, such as voice or chat.
- Co-Browse: Two users can browse the same web page simultaneously. Agents can also assist customers with requests, such as filling an application form.
- Screenpops: Agents are presented with external webpages that can assist them in completing their tasks. For example, external websites with information such as current currency exchange rates.
- Customer history: Users can search customer history to find information about previous interactions with the customer.
- Real-time reporting: Users can access the supervisor reporting dashboard to run real-time reporting dashboards for monitoring up-to-date statistics of your contact center and resources.
- Integration with Proactive Outreach Manager: If Proactive Outreach Manager is configured for Avaya Workspaces, when a user logs in to Avaya Workspaces, Proactive Outreach Manager sends a nail-up call to the user deskphone. When the user answers the deskphone and changes to ready state on Avaya Workspaces, the agent receives outbound work cards. Avaya Workspaces displays the customer details and script widgets with information to help complete the call.

For accessibility purposes, Avaya Workspaces is optimized to conform with Section 508 and WCAG 2.0 AA standards.

Avaya Workspaces provides:

- Access to most content and controls using the keyboard or mouse.

- Alternative text and labels to assist users with screen-readers.
- A color palette that meets requirements for users with visual impairments.

---

## Avaya Analytics™ for Avaya Oceana® overview

Avaya Analytics™ enables supervisors and contact center managers to make better decisions for streamlining operations, reducing costs, and providing improved services. The Avaya Analytics™ reports provides actionable insights from every interaction to drive measurable improvements in customer experience and agent performance. It also analyzes the interaction types that Avaya Analytics™ for Avaya Oceana® supports. Using Avaya Analytics™, supervisors can analyze the current trends in the contact center and enhance agent performance.

Avaya Analytics™ is a software-only solution that provides the following features:

- Historical and real-time reporting on Avaya Oceana®
  - Out-of-the-box historical and real-time reports
- Historical and real-time report customization
- Historical reports scheduling and emailing
- Multiple time zone support

Avaya Analytics™ for Avaya Oceana®:

- Provides a reporting engine to correlate, translate, calculate, and publish historical information. Avaya Analytics™ normalizes and standardizes raw event data across different products and channels. It enables the data collection from Avaya Oceana® and facilitates the use of that data to provide integrated, multichannel reporting across the customer journey. Therefore, organizations can make faster and better decisions to improve operational performance and customer experience.
- Provides producers and measures to Avaya Workspaces for use in real-time reporting dashboards.
- Provides out-of-the-box ability to create individual Business Intelligence dashboards. With role-based access control, administrators can create users and assign them to predefined groups. Users can create, edit, or view reports according to the privileges assigned.
- Integrates with Avaya Oceana®.

Avaya Analytics™ is built on Avaya Common Services. Common Services ensures ease of deployment and supports rolling upgrades, thereby simplifying the upgrade process. Every Avaya Analytics™ service is built according to microservices architecture. Using Common Services, you can deploy and update each service independently, without impacting other services in the solution.

Avaya Analytics™ collects events from Avaya Oceana®. With the collected events, you can create a suite of real-time and historical reports for Avaya Oceana® contact center activities. The evolution of the Avaya Analytics™ reporting platform provides the ability to view and analyze Avaya

Oceana® data using real-time and historical dashboards. You can use Avaya Workspaces to monitor real-time data and use Avaya Analytics™ Web to analyze historical data.

Avaya Analytics™ includes Avaya Analytics™ Web, an intuitive web-based reporting application that provides historical reporting.

Historical Reporting offers:

- A web-based reporting application that provides historical reporting through a simplified interface
- With this interface, you can visualize the contact center performance over a specified reporting time. The interface provides an enhanced user experience for report creation.
- Consolidation of historical contact center performance and customer data across the contact center
- Extensive library of tables, graphics, and ready-to-use displays
- Ability to drill down to granular level information
- Filtering options
- Options to export reports to Excel and PDF formats

 **Note:**

HTML data format is currently not supported.

- Ability to schedule reports to run at user-defined intervals
- Ability to schedule reports to run based on daily roll-up and monthly roll-up data
- Options for calculated measures
- Facility for time zone reporting to display data in the preferred time zone
- Multiple predefined reports
- Option to create custom reports or modify reports to meet your business requirements
- Option for advanced users to import data from different data sources to create reports, documents, and dashboards to report on their imported data.
- Option to export web objects for archiving the custom reports during an upgrade.

---

## Avaya Common Services overview

Avaya Analytics™ is deployed as a product on Avaya Common Services (Common Services).

Common Services provides several common services for Avaya products, such as:

- logging
- alarming

- certificate management
- authentication
- eventing
- event monitoring

Common Services ensures ease of deployment and supports rolling upgrades, thereby simplifying the upgrade process. Every Avaya Analytics™ service is built according to microservices architecture. Using Common Services, you can update a helm chart easily, which enables you to stage and deploy a new service or an updated service version.

You deploy the Common Services Cluster Control Manager (CCM) OVA in your virtual environment. You use CCM to install Avaya Analytics™, and during the install, CCM uses a pre-populated installation spreadsheet to apply your specified configuration, validate the data, configure all required virtual machines, deploy k8s clusters, and install all required services. All other required software is stored in an Avaya repository. You use your Avaya credentials to download this software during deployment. Avaya Analytics™ supports online and offline installs.

Each service has a helm chart, a collection of files that store K8s deployment data, configuration data, scripts, and software required for a successful install. Common Services uses these helm charts, contained in a helm repository, to deploy the Avaya Analytics™ solution.

### **Container technology**

Common Services uses container technology to simplify deployment, configuration, and upgrades. Common Services uses Docker to build and run application containers within a data center. CCM can connect to the Avaya repository to obtain containers used to deploy services. Containers run on the kernel of a virtual machine and do not require a hypervisor. Each Avaya Analytics™ service runs in a container.

Kubernetes (k8s) is a container orchestrator that provides APIs and command lines to enable container deployment automation. CCM deploys a k8s cluster into your virtual environment, which runs on virtual machines (VMs). A cluster contains many nodes; a master node and worker nodes. Containers run on the k8s nodes as pods, and a pod can contain one or more containers deployed together.

# Chapter 3: Architecture

---

## Avaya Oceana<sup>®</sup> architecture

The following diagram depicts the high-level architecture of Avaya Oceana<sup>®</sup>:

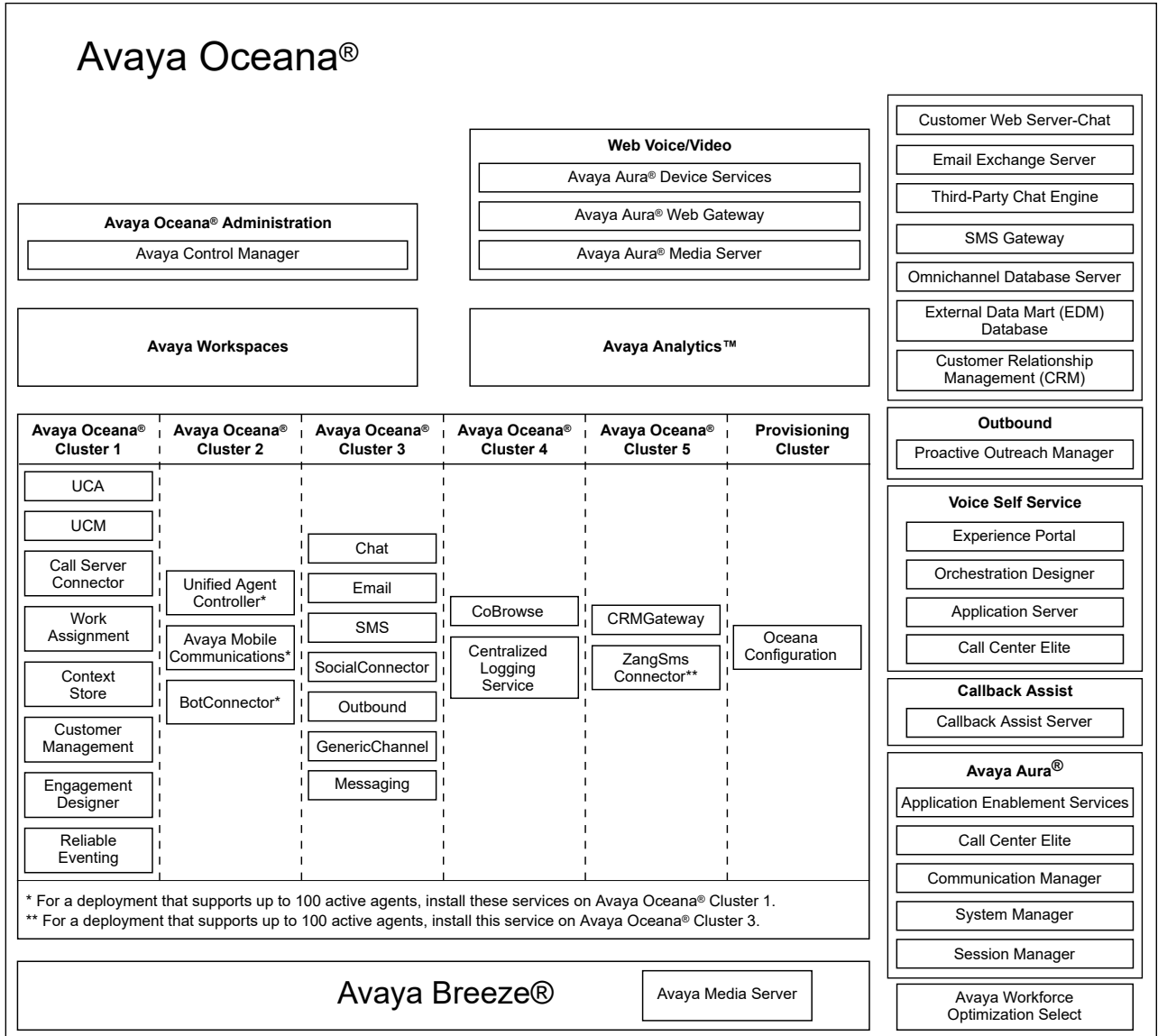

Figure 1: Avaya Oceana® architecture

**! Important:**

- Do not install any third-party or custom Service Archives (SVARs) on Avaya Breeze® platform nodes and clusters that are used in Avaya Oceana®. These nodes and clusters are for the exclusive use of Avaya Oceana®.
- Do not add additional Avaya Breeze® platform nodes to the specified Avaya Oceana® clusters.
- Context Store is intended only to store contextual data that relating to work requests within Avaya Oceana®. Do not use Context Store to store data for any other purpose.

---

## Avaya Oceana® components

The following are the high-level components of Avaya Oceana® that are essential for successful deployment of Avaya Oceana®:

- Avaya Workspaces
- Avaya Analytics™
- Avaya Control Manager
- Avaya Breeze® platform that consists of a set of core multicenter components deployed on different clusters
- Avaya Oceana® Clusters
  - Avaya Oceana® Cluster 1
  - Avaya Oceana® Cluster 2
  - Avaya Oceana® Cluster 3
  - Avaya Oceana® Cluster 4
  - Avaya Oceana® Cluster 5
- Avaya Aura® components
  - Avaya Aura® Communication Manager
  - Avaya Aura® System Manager
  - Avaya Aura® Session Manager
  - Avaya Aura® Call Center Elite
  - Avaya Aura® Application Enablement Services
- Voice Self Service
  - Avaya Experience Portal
  - Avaya Aura® Call Center Elite
  - Orchestration Designer
  - Application Server
- Outbound (optional)
  - Avaya Proactive Outreach Manager
- Web Voice and Web Video (optional)
  - Avaya Aura® Web Gateway
  - Avaya Aura® Device Services
  - Avaya Aura® Media Server

- Supporting components
  - Customer Web Server for Chat
  - Email Exchange Server
  - Avaya Automated Chat for BotConnector
  - Avaya Messaging Automation
  - SMS Gateway
  - Omnichannel Windows Server to install the Omnichannel software
  - Omnichannel Database
  - External Data Mart (EDM) Database
  - Customer Relationship Management (CRM)
  - Avaya Workforce Engagement Select
  - Avaya Workforce Engagement

---

## Avaya Control Manager overview

Avaya Control Manager is an operational administration solution that administrators can use to control key administrative elements across Avaya Oceana<sup>®</sup>. Control Manager operates in Avaya-based contact center and Avaya Aura<sup>®</sup> unified communications environments.

With Control Manager, technical and non-technical administrators can manage several day-to-day operations from a single web-based user interface, such as agents, users, extensions, voice mails, and skills administration. Administrators become more productive as agent provisioning and skill assignments take a fraction of the time required earlier, maximizing preparedness for customer interactions.

Control Manager is a user-friendly centralized administration tool for users to administer day-to-day administration tasks across their complete Avaya-based environment. Control Manager is offered as an entitlement when bundled with Avaya Oceana<sup>®</sup>.

Control Manager facilitates as a single point of administration for Avaya Oceana<sup>®</sup> elements such as reporting, multimedia, and multichannel. Administration is performed through a centralized administration portal integrated with Control Manager.

Control Manager can work with Avaya Aura<sup>®</sup> Call Center Elite. When you deploy Control Manager at an existing Call Center Elite customer site, it can extract the existing configuration information from Call Center Elite. Using Control Manager, an administrator can use Avaya Oceana<sup>®</sup> to target an existing Call Center Elite agent.

In Avaya Workspaces, Avaya Oceana<sup>®</sup> includes a connector to Control Manager to provide centralized management capabilities. This capability is included in the Avaya Oceana<sup>®</sup> base license. Administrators can use Control Manager as a consolidated place for all Avaya Oceana<sup>®</sup> related contact center administration functionality, such as user administration of agents and supervisors, Work Assignment attributes, hunt groups, skills, VDNs, tenants. Administrators can continue to manage other Avaya solution elements supported by Control Manager.

Unified Collaboration Administration stores the configuration information entered in Control Manager and makes this information available to the other multicenter applications as required.

### **Control Manager for Avaya Oceana® and Avaya Workspaces**

- There is a tracking material code for Control Manager when accompanied by Avaya Oceana®.
- Control Manager connectors bundled under this entitlement include Avaya Aura® core, Call Center Elite, and Avaya Oceana®. Other connectors must be purchased. Enabled connectors can be combined with an existing Control Manager license, if owned by the customer. The quantity of entitled concurrent users included must be linked to the quantity of Avaya Oceana® supervisors purchased in a one-to-one ratio.
- This entitlement does not include:
  - the new Multiplex High Availability (HA), using the Microsoft SQL AlwaysOn feature
  - the Legacy HA features.

There is a tracking material code for Control Manager when accompanied by Avaya Workspaces. It includes Avaya Aura® core, Call Center Elite, Avaya Workspaces connectors, and an entitlement for 25 concurrent administrator logins.

### **Supported Avaya Oceana® administrative capabilities**

- Create, edit, and delete agents
- Create, edit, and delete Work Assignment attributes
- Configure Work Assignment channels and multiplicity per agent
- Assign Work Assignment attributes and proficiency to agent
- Set agent supervisor
- Bulk updates of agent properties
- Configure system parameters
- Support up to 15 instances
- Support video-enabled agents
- Create, edit, and delete email templates
- Edit email settings
- Configure email signature settings
- Configure email deferral codes
- Add, edit, and delete Workspaces groups
- Assign Workspaces groups to users
- Create and configure thresholds for Avaya Analytics™
- Configure service and reserve level thresholds
- Configure Channel Exclusivity global settings
- Add users for Workspaces
- Add users for the supervisor reporting dashboard for Workspaces

- Assign reporting access to Workspaces users
- Configure agent timeout for the Avaya Oceana® and Avaya Workspaces
- Configure a default Not Ready reason code for the Avaya Oceana® and Avaya Workspaces
- Configure Auto answer timeout for a provider
- Configure Auto answer for a user profile template
- Assign a user profile template with Auto answer to an agent
- Create routing service groups for Work Assignment

---

## Avaya Breeze® platform overview

Avaya Breeze® platform provides a virtualized and secure application platform where workflow developers and Java programmers can develop and dynamically deploy advanced collaboration capabilities. These capabilities extend the power of Avaya Aura®. Customers, business partners, and Avaya developers can use the Avaya Breeze® platform to deploy snap-ins.

Avaya Breeze® platform provides the following:

- Unified Communications, Contact Center customers, and Business Partners can deliver capabilities using the skill sets of enterprise and cloud application developers.
- A robust Software Development Kit (SDK) with an easy-to-use API. Developers need not understand the details of call processing to develop new capabilities.
- A Collaboration Bus that snap-ins can leverage capabilities through a point-to-point model and publish or subscribe to messaging patterns.
- A Common Data Manager framework that snap-ins can use to access common information stored on System Manager.
- Connector snap-ins that provide access to email and conferencing host applications.
- Zang call connector to interact with Zang.
- Zang SMS connector for snap-ins to interact with Zang to send and receive messages.
- Tools that log and monitor operations and provide troubleshooting support.

Avaya products such as Avaya Oceana®, Avaya Engagement Designer, Avaya Aura® Presence Services, and Avaya Context Store are powered by the Avaya Breeze® platform.

With the Avaya Breeze® platform, you can:

- Develop the snap-ins without developing the platform to deploy and invoke snap-ins.
- Perform the following operations:
  - Intercept calls to and from the enterprise.
  - Redirect calls to an alternate destination.
  - Block calls and optionally play an announcement to the caller.

- Change the caller ID of the calling or called party.
- Place an outbound call for playing announcements and collecting digits.
- Use web services for added functionality.
- Make web pages and web services available for remote browsers and applications.
- Add or replace trust and identity certificates for increased security.
- Create custom connectors that provide access to an external application or service.

---

## Avaya Oceana® Clusters overview

As part of the deployment of Avaya Oceana®, you create Avaya Oceana® Clusters on Avaya Breeze® platform nodes. A cluster provides scaling by distributing the services across multiple Avaya Breeze® platform nodes. With this distribution of services, Avaya Oceana® achieves overall throughput and avoids interruption in the event of failure. Clients access the services through the Cluster IP address.

### Avaya Oceana® Cluster 1

This cluster consists of the following snap-ins:

Snap-in	Description
Unified Collaboration Administration (UCA)	Stores the configuration information entered in Avaya Control Manager, and makes this information available to the other multicenter applications as required. The configuration information used by Unified Collaboration Administration consists primarily of the resources, that is agents, and is managed by Avaya Oceana®.
Unified Collaboration Model (UCM)	Acts as a central point of normalized resource and work state in Avaya Oceana®. Work refers to interactions such as inbound voice calls and web chats.
Call Server Connector	Acts as an interface between Communication Manager and the Avaya Oceana® application tier. It maintains the state of Unified Collaboration Model for all agents and stations registered on Communication Manager.
Work Assignment	Acts as an enterprise wide Matching Engine for Avaya Oceana®. It matches the request with the most suitable resource available.
Context Store	Acts as a Memory Data Grid that can store contextual information provided by the customer's Enterprise Applications. These applications route data and historical data to be shared between Experience Portal, Engagement Designer, Work Assignment, and the multimedia Snap-Ins such as chat and email. These components also display customer data to Agents and show historical Journey information.

*Table continues...*

Snap-in	Description
Customer Management	<p>Aggregates customer information from all available sources to provide a single interface where client components can manage and retrieve customer information. This interface reduces the number of integrations that clients require for managing customer information, abstracting clients from CRMs, Context Store, Omnichannel Database, Avaya Proactive Outreach Manager, and any other customer data sources added to Avaya Oceana®.</p> <p>The managed customer information includes:</p> <ul style="list-style-type: none"> <li>• Avaya Oceana® customer information</li> <li>• Customer records stored in a third-party CRM</li> <li>• Customer journey based on Context Store audit trails</li> </ul>
Engagement Designer	Acts as the business workflow execution engine of Avaya Oceana®. All interaction types, such as voice, email, and chat, start an Engagement Designer workflow.

### Avaya Oceana® Cluster 2

This cluster consists of the following snap-ins:

Snap-in	Description
Unified Agent Controller (UAC)	Acts as a server-side component that manages the connections to the individual agent desktops. It has access to agent configuration that is made available to the Unified Agent Controller component.
Avaya Mobile Communications	Integrates the Web Voice/Web Video capability provided by Avaya Aura® Web Gateway into Avaya Oceana®. Avaya Mobile Communications supports attribute-based routing of WebRTC calls made through customer mobile and web applications.
BotConnector	Acts as an interface for the automation of short messages from a chat provider by acting as a proxy to the API of Avaya Automated Chat server.

### Avaya Oceana® Cluster 3

This cluster consists of the following snap-ins:

Snap-in	Description
Omnichannel Provider	Provides the option to add additional media to an established interaction. It includes Email, Chat, SMS, Social Media, Messaging, Generic, and Outbound.

### Avaya Oceana® Cluster 4

This cluster consists of the following snap-ins:

Snap-in	Description
CoBrowse	Provides web collaboration between two users. Customers and agents can then jointly browse webpages and complete web forms.

*Table continues...*

Snap-in	Description
Centralized Logging Service	Provides the option to view the logs for all services of Avaya Oceana® clusters through a centralized interface.

### Avaya Oceana® Cluster 5

This cluster consists of the following snap-ins:

Snap-in	Description
Avaya CRMGateway	Provides a normalized access layer between Avaya Oceana® and Customer Relationship Management (CRM) systems of customers.
ZangSmsConnector	Provides SMS support using the ZangSmsConnector snap-in.

### Provisioning cluster

This cluster does not contain any Avaya Breeze® platform nodes. This cluster consists of the following snap-in:

Snap-in	Description
OceanaConfiguration	Distributes snap-in attributes to every snap-in across the remaining Avaya Oceana® clusters.

---

## Avaya Aura® components

The following table lists the Avaya Aura® components that are essential for successful deployment of Avaya Oceana®:

Component	Description
Avaya Aura® Communication Manager	Acts as a telephony application that connects to private and public telephone networks, Ethernet LANs, and the Internet. Communication Manager organizes and routes voice, data, image, and video transmissions.
Avaya Aura® System Manager	Acts as a central management system that provides a set of shared management services and software management solution to support deployments, migrations, upgrades, and updates to the suite of Avaya Aura® applications.
Avaya Aura® Session Manager	Acts as a SIP routing tool that integrates all SIP devices across the enterprise network.  Session Manager simplifies the existing communication infrastructure by combining existing PBXs and other communications systems, regardless of the vendor, into a cohesive, centrally managed, SIP-based communications network.

*Table continues...*

Component	Description
Avaya Aura® Call Center Elite	Forms the core part of the solution and provides voice capabilities for Avaya Oceana®. Avaya Oceana® leverages Elite features such as RONA, Observe, and Calendaring.
Avaya Aura® Application Enablement Services	Leverages the capabilities of Communication Manager and provides an enhanced set of Application Programming Interfaces, protocols, and web services. This exposes the functionality of Avaya Communication solutions to corporate application developers, third-party independent software vendors, and system integrators.

---

## Voice Self Service overview

In Avaya Oceana®, you can use any of the following components for Voice Self Service:

- Avaya Experience Portal
- Avaya Aura® Call Center Elite

These components provide an Interactive Voice Response (IVR) front-end for voice calls in Avaya Oceana®.

If you choose Experience Portal for Voice Self Service, you use:

- Orchestration Designer to create custom voice applications by importing the sample application source code and using it as a starting point.

Orchestration Designer is an Eclipse plug-in that you can use to create applications for Experience Portal.

- Application Server to deploy Experience Portal Self Service Application.

---

## Outbound overview

Avaya Oceana® provides the Outbound voice capability by integrating with Avaya Proactive Outreach Manager (POM). With this integration, POM serves as an Outbound channel for Avaya Oceana®.

---

## Web Voice and Web Video overview

The following table lists the components that are essential for Web Voice and Web Video in Avaya Oceana®:

Component	Description
Avaya Aura® Web Gateway	Acts as a WebRTC signaling gateway.

*Table continues...*

Component	Description
Avaya Aura® Device Services	Used for WebRTC agent registration.
Avaya Aura® Media Server	Used for WebRTC media.  Performs all multimedia processing using software. Media Server works with media gateways to provide a streamlined voice and data network throughout the enterprise.

## Avaya Engagement Designer for workflow design support

Avaya Oceana® includes Avaya Engagement Designer, which is a user-friendly workflow design tool. The Avaya Engagement Designer provides the capability to define, administer, and run end-user customer journeys across Mobile Collaboration, Unified Communications, and Contact Center applications. Engagement Designer offers business analysts, non-technical resources, and developers the opportunity to write logical business process flows. These process flows can leverage any Avaya Breeze® platform snap-ins that have an associated palette of tasks. Engagement Designer allows users to:

- **Dream:** Easily create complex, end-to-end communications enabled business process across both mobile collaboration and contact center applications, and leveraging a range of 3rd party applications snap-ins with a single tool.
- **Design:** Developers and business users alike can use an intuitive drag and drop GUI environment to build business processes. Leveraging a rich palette of tools, Engagement Designer can easily leverage 3rd party or other processes, straight from the GUI environment, with no additional coding necessary.
- **Deploy:** Easily deploy business processes that leverage built in tools from Avaya Breeze® platform including high availability, redundancy and security. Engagement Designer significantly reduces cost and time to market associated with highly custom CTI middleware development.

Using Avaya Engagement Designer you can visually drag and drop design approach to bring the right resources, content, and context together across your CRM and other systems to deliver a holistic customer engagement management environment.

Flexible workflows can change with business needs, reduce cost, and increase the speed of implementing customer journey workflows.

Avaya Engagement Designer also provides the option to compare two Engagement Designer workflows using Engagement Designer Diff Tool.

When you upgrade Avaya Oceana®, you can use this tool to identify the customizations of the earlier workflows and migrate those customizations to the latest workflows.

Currently, this tool cannot measure the difference in terms of mapping information. It can only identify the differences such as addition or deletion of a node and modifications in the properties of a task.

## Work Assignment overview

Work Assignment is a highly available work distribution system that assigns work to resources across your enterprise. Work Assignment provides attribute-based work and resource matching capabilities. Work Assignment can match one-to-one and one-to-many resources, find the most suitable resource for a work item, and form a dynamic team of resources based on the requirements.

Work Assignment maintains all resources across the enterprise in a single pool and assigns work using a single universal matching engine and attributes-driven routing.

Work Assignment offers the following functionality:

- Match resources to incoming requests based on attributes.
- Match work to one resource at a time to find the most suitable resource for the requested work.
- Match work to a number of homogenous resources, as specified in the work request.
- Match work to a group of heterogeneous resources.
- Match work to a resource in a work surplus situation.
- Reject a resource.
- Retrieve metrics associated with a set of attributes.
- Configure agents with different proficiency levels.
- Prevent agents from avoiding work.

---

## Work Assignment features

### Attribute-based Matching

Using the Attribute-based Matching feature, Work Assignment finds the most suitable resources to assign work. To find resources for your work, you must define a set of attributes and send a work request to Work Assignment.

Attributes describe the type of work that a resource can handle. The following are a few examples of attributes:

- Knowledge of a particular language
- Capability to work on a particular channel

As the first step in matching work and resources, Work Assignment uses attributes to filter resources who have the required knowledge and skills. After filtering the resources, Work Assignment uses its strategies, Resource Selection Strategy and Work Selection Strategy for resource selection.

For matching and reporting, Work Assignment considers one or more attributes together.

## Service Metrics

Using the Service Metrics feature, you can obtain metrics for a specific attribute set or service. To obtain the metrics, you must provide at least one attribute set. An attribute set consists of at least one key-value pair of attribute category and value, in the form of `[category, Value]`. You can also specify a priority for the metrics. If you do not specify a priority, Work Assignment uses the default value.

Metrics allows you to check six services at a time.

Metrics can be of two types:

- per Service

The priority is null.

- per Service per Work Priority

The priority range is 0 to 10, with 10 being the lowest priority.

Any references to Resource in the context of Metrics refer to the routable address; that is, the entity that Work Assignment monitors for the availability state of resources, and the entity that Work Assignment returns in response to a successful match request. A service represents the attribute set combination specified or realized on incoming work.

When you provide the input parameters for Service Metrics, Work Assignment provides the following metrics:

Metric	Description	Per Service	Per Service Per Work Priority
ResourceReadyCount	Number of resources Available to be assigned work from the Service.	Y	Y
ResourceBusyCount	Number of resources with the Service currently ON WORK.   <b>Note:</b> If a resource has multiplicity >1, it can be both Busy on work and still Ready for more work. Therefore, the resource is counted in this metric and the previous metric.	Y	Y
ResourceStaffedCount	Number of resources logged in on this service. Independent of current availability.	Y	Y

*Table continues...*

Metric	Description	Per Service	Per Service Per Work Priority
WaitingWorkCount	Number of work items associated with the Service that are to be Accepted by a Resource.	Y	Y
ProcessingWorkCount	Number of work items associated with the Service that are in process. Total number of work items currently on work.	Y	Y
CompletedWorkCount	Number of work items associated with the Service that are processed by a Resource.	Y	Y
OldestWorkWaiting	The oldest work item that is to be Accepted by a Resource. The value is measured in seconds.	Y	Y
Rolling ASA (Rolling average speed of answer)	Rolling Average Speed of Answer. The value is measured in seconds.	N	Y
Service Occupancy	The percentage ratio of Busy Resource to Staffed Resources per Service.	Y	Y
EWT (Estimated wait time)	Estimated Wait Time. The value is measured in seconds.	N	Y
Occupancy	The Resource Occupancy, that is, a historical average, taking historical data into account.	N	N

**\* Note:**

- You must provide priority values in your query to obtain data for WaitingWorkCount, ProcessingWorkCount, CompletedWorkCount, and EWT.
- Service metrics is only supported in a deployment with resource provider adapter.
- To obtain metrics for a service, the service must preexist.

## Single resource requests

### Request Resource

Using the Request Resource feature, you can send a work request to Work Assignment to find a single resource based on up to six attribute sets. To use the Request Resource feature, you must define the attribute sets and send a work request to Work Assignment.

Upon receiving the work request, Work Assignment attempts to match a resource based on the specified attribute sets. After identifying a resource, Work Assignment reserves the resource and sends you the details of the resource. You can assign work to the resource or cancel the request.

If Work Assignment does not find an available resource for the specified attribute sets, the request waits in a queue until a suitable resource becomes available. If more than one request is waiting in a queue, Work Assignment first selects the request with highest priority. Work Assignment applies Resource Selection Strategy to select a resource from a list of suitable resources. If you do not specify any Resource Selection Strategy, Work Assignment applies the preconfigured default strategy.

To maximize the chances of finding a resource, you can use the Queue to Multiple feature. This feature is applicable only when you are requesting a single resource. This feature serves as a single-step execution of multiple Request Resource operations. When there is a single resource, Work Assignment attempts to find the best available resource in multiple services. If Work Assignment does not find any resource, the system queues the work against multiple services. If Work Assignment finds multiple resources, the system selects the best resource based on rank or Resource Selection Strategy steps, such as proficiency or occupancy. The system reserves the resource after the resource is finalized.

#### Important:

- You can assign work to a resource only if the resource is available.
- Work Assignment supports queuing of requests only when you are requesting a single resource.

### Match Update

Using the Match Update feature, interaction management applications, such as Engagement Designer, can update the work item that is queued for resources within Work Assignment.

Using the Match Update feature, you can:

- Update the priority of the waiting services that are added to a work item.
- Add, remove, or update services for queued work items.

While performing a match update:

- The work request must be in queued state.
- You cannot change the strategy of a work item.
- You cannot add the service rank.
- Work Assignment moves the previous service out of the queue and adds a new service in the queue.

- Work Assignment preserves the time in queue after an update. Also, a failed update does not dequeue the already queueing work items.

## Service Rank

Using the Service Rank feature, you can rank the service preferences for a work item. This feature is applicable only when you use Queue to Multiple.

When multiple resources are available for a match request having multiple services, Work Assignment uses the rank of the service to determine which resource is matched.

Rank is relevant only within the list of services that you request for a particular work item. However, the priority is relevant to all work items in a queue.

For example, if resources are available in more than one service, you can send the following resource requests to Work Assignment:

- Service A, rank 1
- Service B, rank 2
- Service C, rank 3

After receiving the work request, Work Assignment lists the services according to the rank and provides information about the services with the highest rank. If resources are available in more than one service, Work Assignment uses the Service Rank feature to ensure that the service with a highest rank is matched. If you have more than one available resource, the resource selection based on the Idle time or occupancy can be a concern.

In this example, a resource matching Service A, rank 1 is matched.

If one or no resource is available for the requested service, Work Assignment applies the default strategies to the request. If you do not provide a rank to any service, Work Assignment applies the default value of null. If you provide the rank only to some services, Work Assignment applies the lowest rank to the services without a rank.

Rank only applies in a resource surplus scenario. If no resources are available and the request is queued, the system ignores the rank and applies the Work Selection Strategy.

### **Note:**

Work Assignment does not support the Service Rank feature in the MatchUpdate request.

## Specified Resources

Using the Specified Resource feature, you can route work to a customer-specified resource. This feature is applicable to all new and updated work requests.

Specified resources can be of two types:

- Preferred Resources: Resources that can be requested with the list of services. If no Preferred Resource or a resource from the specified services is available, the work waits in queue until a resource becomes available.
- Required Resources: Resources that are requested without the list of services. If no Required Resource is available, the work waits in the queue until a Required Resource becomes available.

Work Assignment provides the ability to specify up to six specified resources in a Request Resource. If a work with specified resource waits in the queue for a long duration, you can update the work request. When updating a Request Resource, the client can update the services but cannot update the specified resource.

Examples of Work Assignment features that use Specified Resource functionality:

- Last Agent Routing: Context store has information about the last agent who addressed customer, when the customer returns to the call centre. A look up is done from context store and agent information is acquired. This information is passed to Work Assignment automatically and the work is queued to that agent. If the agent is unavailable, a service is then added to the Work so that anybody on the service can be assigned to that work.
- Defer Email: When an agent defers an email, it remains in the database for a certain period. Avaya Oceana® then attempts to route the email back to the original agent. The original agent is sent in the request to Work Assignment and the work is queued to them. If the agent is unavailable for a certain period, an additional service is added to the work through an update and the work is assigned to any agent on that service.

An agent is allowed to defer only ten emails.

- Transfer to user: An agent passes the incoming work to a different agent who is more qualified to address an incoming customer query. The target agent is sent in the request in Work Assignment and the work is queued to that agent. If the agent is unavailable after a certain period of time, a service is attached to the work and the work is assigned to any agent on that service.

These are types of specified resources but:

- At the first stage where only the information about an agent is sent in a request without any service, it is a Required Resource.
- At the second stage when the update occurs and a service is attached, there is both a service and an agent information. This is considered as a Preferred Resource.

## Request resources

### Request Multiple Resources

Using the Request Multiple Resources feature, you can send a work request to Work Assignment to find more than one resource based on a particular attribute set. While sending a work request, you must specify the total number of resources that you require.

In the work request, you must specify whether you need a full match or a partial match.

- If you specify a full match and Work Assignment does not find the total number of required resources, Work Assignment notifies you with the WORK\_UNFULFILLED response.
- If you specify a partial match and Work Assignment does not find the total number of required resources, Work Assignment returns the number of available resources.

In this case, Work Assignment notifies you with the WORK\_UNFULFILLED response only when it does not find even a single available resource.

Work Assignment attempts to match resources based on the attribute set. Work Assignment matches each resource for all attributes defined in the attribute set. After identifying the required

number of resources, Work Assignment reserves the resources and sends you the information of the resources. Using the information, you can assign work to the resources.

**! Important:**

Work Assignment does not support queuing for this feature.

## Request Group of Resources

Using the Request Group of Resources feature, you can send a work request to Work Assignment to find a group of resources based on multiple attribute sets. While sending a work request, you must specify the total number of resources that you require for each attribute set in the group.

Work Assignment attempts to match a group of resources based on the attribute sets in the group. Work Assignment matches each resource for all attributes defined in the attribute set. After identifying the group of resources, Work Assignment reserves the resources and sends you the information of the resources. Using the information, you can assign the work to the group of resources.

If Work Assignment does not find the total number of required resources, Work Assignment notifies you with the `WORK_UNFULFILLED` response. Also, Work Assignment releases the other matching resources and cancels the request. For any retries, you must send a new work request.

**! Important:**

You can assign work to resources only if all resources in the group are available. Work Assignment does not support queuing for this feature.

## Partial Team Request

Using the Partial Team Request feature, you can send a work request to Work Assignment to return a successful result even if the number of available resources is less than the number of requested resources. This feature is applicable only when you use the Request Multiple Resources and Request Group of Resources features.

To use the Partial Team Request feature, you must set **MatchType** as **Partial** in the work request.

For example, if you request five resources and less than five resources are available, the response lists the number of available resources. Work Assignment notifies you with the `WORK_UNFULFILLED` response if you did not use Partial Team Request. This feature is useful for an emergency response scenario where the user wants to continue with any number of resources that are available.

If at least one resource is available, the request is successful.

If you do not set **MatchType** to **Partial**, Work Assignment uses the default value, **Full**. In this case, the system responds with a failed request if the number of available resources is less than the number of requested resources.

When using Engagement Designer as the client, you can set **MatchType** to **Partial** either in the input mapping or in the task properties.

If you configure both **Partial** and **Full** values in the work request, the value that you specify in the task properties takes precedence.

## Selection strategies

### Resource Selection Strategy

Using the Resource Selection Strategy feature, Work Assignment selects the most suitable resource from the pool of resources. If Work Assignment does not find any available resource, Work Assignment keeps the work item in the queue and applies Work Selection Strategy.

You can specify the following Resource Selection Strategies:

- **Most Idle:** Work Assignment selects a resource that has not processed any work for the longest time.
- **Least Occupied:** Work Assignment selects the resource that is least occupied.

Occupancy is the ratio of the time in busy state to the time in available state. Work Assignment updates this metric for all resources at an interval of 18 seconds.

### Work Selection Strategy

Using the Work Selection Strategy feature, Work Assignment can find the most suitable work for a particular resource. The Work Selection Strategy feature is applicable only on transition of a resource to available state. Work Assignment scans all waiting work that matches the attributes of the resource and sends the information about the resource.

For each resource, the Work Assignment administrator can select one of the following Work Selection Strategies:

- **Greatest Need:** When a resource becomes available, Work Assignment scans all waiting work items that match the attributes of the resource and selects the highest priority work with the longest wait time. This is the default Work Selection Strategy.
- **Skill Level:** When a resource becomes available, Work Assignment scans all waiting work items that match the attributes of the resource and selects the longest waiting work for which the resource is the most proficient.

### Property based strategy enhancement

#### *Proficiency*

When you send a work request, Work Assignment selects the most suitable resource available from the pool of resources. The selection is based on the defined proficiency values for the resources.

You can define proficiency for Work Assignment resources through:

- **System default:** The default value of proficiency for all resources in your system. If you do not set the proficiency for individual resources, Work Assignment uses this value as the proficiency of all resources for all services.
- **Default resource proficiency:** The default value of proficiency for all services for a particular resource. Work Assignment considers this proficiency value for all services for the particular resource.

- **Derived proficiency:** Proficiency values for individual categories for a resource. Based on the specific proficiency for different categories, Work Assignment derives a proficiency value for the particular resource for a requested service.

Using Avaya Control Manager, you can configure the default proficiency and add or remove categories from the property. For proficiency, you must specify a numeric value from 1 through 16. A lesser value denotes a higher proficiency.

Using Avaya Control Manager, you can also configure the proficiency for individual resources.

For deployments with no resource provider adapter, you must administer proficiency carefully so that Work Assignment does not assign all incoming work to the same set of resources who have the highest proficiency level.

### **Multiplicity**

ResourceState events show whether a resource is in the logged in state or the resource is available to process work. Currently, with Call Center Elite, a resource can handle only one item of work. Therefore, Work Assignment can conclude that the corresponding account is unavailable if work is in progress. However, with Multiplicity, a resource can handle many work items.

Using the Multiplicity feature, you can simultaneously assign multiple requests from the same channel to one resource. You can configure Multiplicity for non-voice channels. For example, Email and Chat. A multiplicity of 2 for Chat specifies that the resource can simultaneously handle up to two Chat assignments. You can specify Multiplicity as a property of resource accounts.

A resource can have multiple accounts. You can specify Multiplicity for each account and not only for a resource. Multiplicity rules are not applicable to a service, a channel, or resources that are in the Always Available state. Work Assignment considers availability and multiplicity of an account before assigning work to the account.

#### **\* Note:**

Multiplicity is applicable only in deployments where Resource Provider Adapter is present.

### **Service Excluded**

Work Assignment selects resources for an incoming work request based on the attributes of the request and resources. However, you can exclude specific services from the selected resources by configuring the Service Excluded property of the Work Assignment resources.

You can configure the Service Excluded property through:

- **System default:** By default, the Service Excluded value for all resources of Work Assignment is false. If you do not change this value or configure default values for individual resources, Work Assignment does not consider Service Excluded for any resource.
- **Default resource property:** You can override the system default value and specify a different Service Excluded value for an individual resource. Work Assignment considers this value of Service Excluded for all services for the particular resource. By default, each permutation of every attribute is allowed for a given resource. For example, an agent who handles English voice calls and emails. The agent can also answer French emails, but the spoken French is very limited.

This agent has the following attributes:

- Language.English
- Language.French
- Channel.Email
- Channel.voice

The agent has the [Language.French, Channel.voice] permutation for work. The Service Exclusion allows customers to remove unwanted permutations.

- **Derived Service Excluded:** You can set different Service Excluded values for different categories for a resource. While selecting a resource for a work request, Work Assignment considers the combinations of these Service Excluded values for different categories for the particular resource.

You can configure the default system property through Avaya Control Manager. You can also add or remove categories from the property.

You can also configure Service Excluded for individual resources through Avaya Control Manager. You must configure Service Exclusion in the Properties tab of the selected resources.

## Query Resources

Using the Query Resources feature, you can obtain a list of qualified resources based on a specific attribute set. However, you cannot use the list to assign work to resources, because Work Assignment does not consider the availability of resources while compiling the list. Also, Work Assignment does not reserve the resources that match the query.

The Query Resources feature returns a list of the first 50 resources that match the query. You can sort the list of resources based on Availability, Proficiency, or Least Occupancy. Work Assignment does not include the resources that are excluded from service.

## Cancel request

When you send a work request to Work Assignment, Work Assignment processes the request and offers you the most suitable resources based on your work request. You can cancel a work request waiting in the queue by using the Cancel option. When Work Assignment sends you an offer, Work Assignment keeps the resources reserved for you for 120 seconds. If you do not accept the offer within 120 seconds, Work Assignment automatically cancels the offer and makes the resources available for other requests.

## Reject

When the provided resource is no longer to be used and you need a new resource, you can reject the provided resource by using the Reject option.

You must use this option in any of the following cases:

- The provided resource is invalid or unreachable
- You need a different alternative resource.

## Proficiency Range

Agents in a system can be configured based on their proficiency levels for different services, so that a customer can request a matching agent with a particular range of proficiency. A proficiency level can have any numeric value between 1 to 16. The proficiency level with a value of 1 specifies the most skilled and most competent agent and the proficiency level with a value of 16 specifies the least skilled and least competent agent.

You can define the proficiency of an agent in an attribute set. For a particular agent, there can be multiple valid attribute set combinations. You can configure proficiency for all or few of the valid attribute set combinations. If an attribute set is not set to a specific proficiency, it gets the value from the default value from agent level or system level.

While requesting a resource, clients can specify a proficiency range in the request. The proficiency range contains minimum proficiency and maximum proficiency values, where the numeric value of the minimum proficiency must be greater than or equal to the numeric value of the maximum proficiency. These numeric values must be between 1 and 16. For example, if the maximum proficiency value is 6, then the minimum proficiency value can be any number between 6 and 16.

When a client specifies a proficiency range in a request, Work Assignment selects the agent matching to the specified proficiency range. If no agent is available in the specified proficiency range, Work Assignment selects an agent outside of the specified proficiency range.

## Aux Gaming Prevention

Agents in a system might avoid work by changing their state from Ready to Not Ready to Ready. To prevent this, Work Assignment provides the Aux Gaming Prevention feature. This feature must be implemented only by updating the idle timestamp of the agents when the agents complete their work and are completely idle.

---

## Avaya Workspaces for Avaya Oceana<sup>®</sup> architecture

The following is the architecture diagram of Avaya Workspaces for Avaya Oceana<sup>®</sup>:

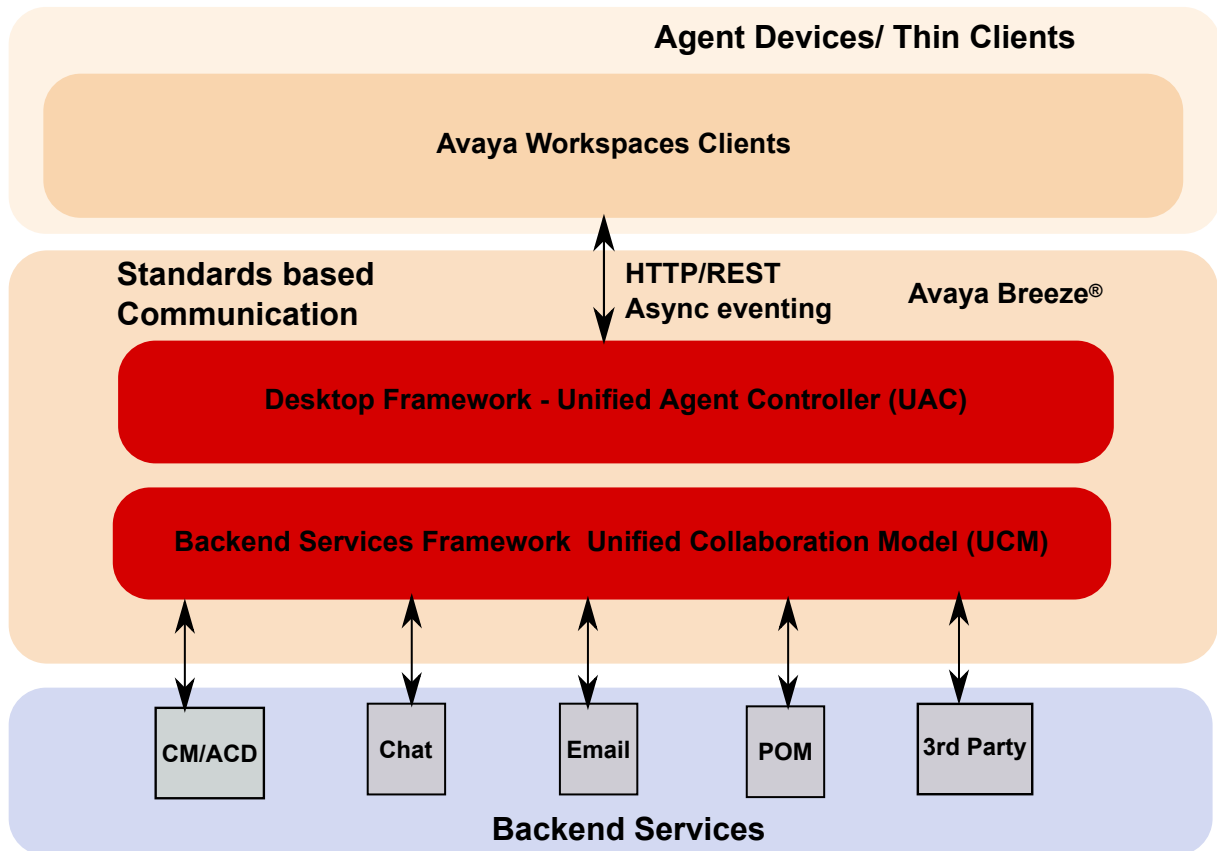

**Figure 2: Architecture**

Avaya Workspaces uses Unified Agent Controller Snap-in, Unified Collaboration Model Snap-in, and backend services for email, chat, and other services.

## Avaya Workspaces for Avaya Oceana® components

Avaya Workspaces consists of the following components:

- Avaya Workspaces client: The Avaya Workspaces web application with features to help agents and supervisors perform their day-to-day activities.
- Avaya Workspaces Client Software Developer Kit (SDK): An SDK used by Avaya Workspaces to deliver features.
- Unified Agent Controller Snap-in: An Avaya Breeze® platform snap-in that unifies all services in Avaya Oceana® to a central integration point for the SDK.

# Avaya Analytics™ for Avaya Oceana® architecture

The following diagram depicts the architecture for the deployment of a typical Avaya Analytics™ reporting solution with High Availability (HA) deployment options:

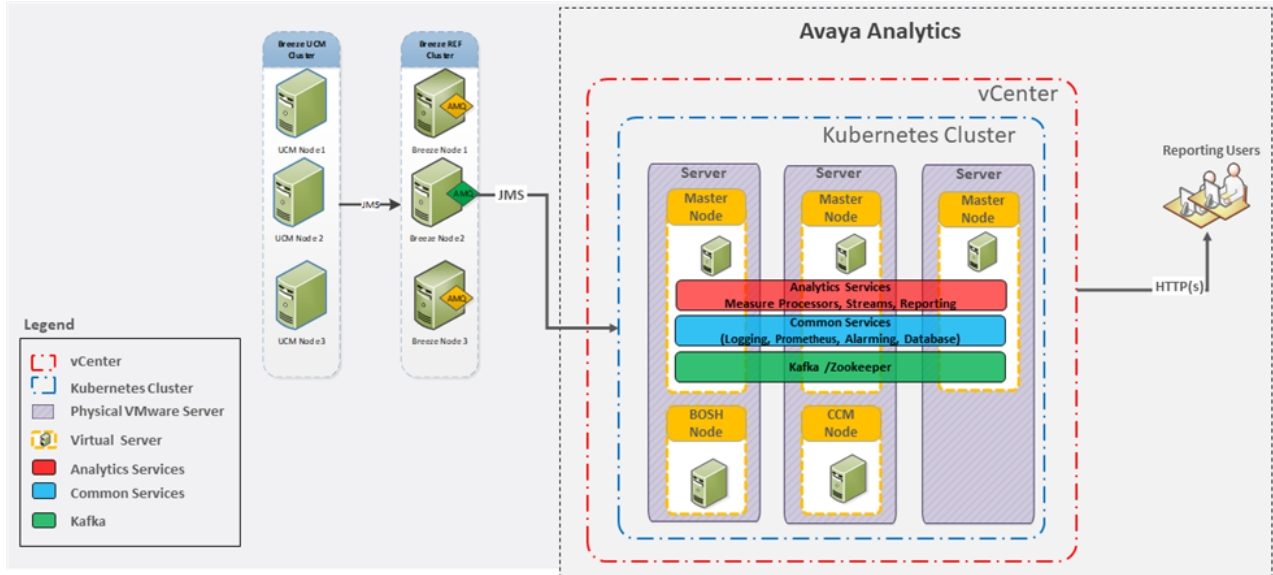

In Avaya Analytics™, the operational report database gets deployed automatically with a primary and standby instance. Avaya Analytics™ measure processors are deployed as a primary or standby pair and the streams services are deployed with a replica count of two on the cluster facilitating load balancing and high availability. You can enable Avaya Analytics™ high availability before deploying the solution. The streams services provide producers and measures to Avaya Workspaces for use in real-time reporting dashboards.

The following diagram depicts the architecture for the deployment of a typical Avaya Analytics™ reporting solution with non-HA deployment options:

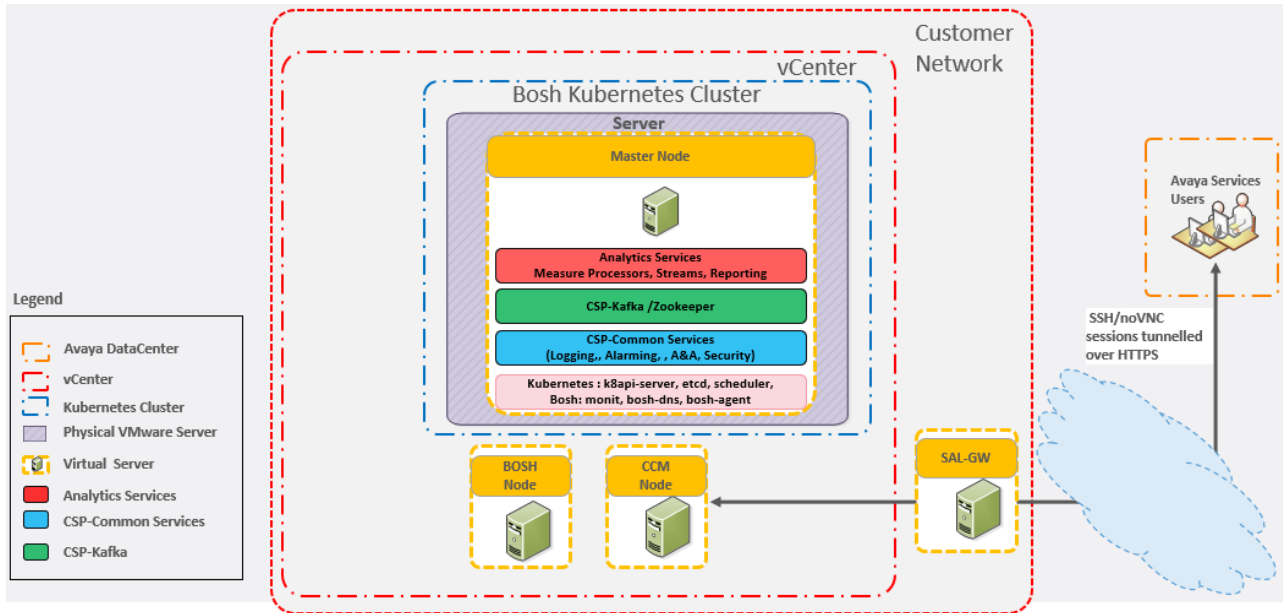

Avaya Analytics™ provides non-HA support for agent footprints with 100, 500, and 1000 agents that you can use in lab and production environments. Non-HA deployments reduces the number of physical servers required to 1 server and eliminates the vSphere Enterprise Plus license requirement because DRS is no longer required. Non-HA deployments also reduces the footprint because only one instance of each application pod is deployed.

## Avaya Analytics™ for Avaya Oceana® components

Avaya Analytics™ consists of the following components:

- **Avaya Common Services:** Avaya Analytics™ is deployed as a product on Avaya Common Services (Common Services). Common Services uses container technology to simplify deployment, configuration, and upgrades. Common Services uses Docker to build and run application containers within a data center.
- **Avaya Analytics™ Historical Reporting:** An intuitive web-based reporting application that provides historical reporting. With this interface, you can visualize the performance of the contact center over a specified reporting time. The interface provides enhanced user experience for report creation. For more information, see the Avaya Analytics™ overview section in this document.
- **Avaya Analytics™ Real Time Reporting:** Dynamic dashboards in Avaya Workspaces for Avaya Oceana® that displays real-time up-to-date contact center performance statistics.
- A terminal tool that you can use to configure post installation settings, troubleshoot common issues, and check system health.

# Chapter 4: Interoperability

## Components

The following tables provide a brief description of the components essential for the successful deployment of Avaya Oceana®. For more information about deployment, see *Deploying Avaya Oceana®* and *Deploying Avaya Analytics™ for Avaya Oceana®*.

**Table 1: Core components**

Component	Role
Avaya Oceana®	Provides enterprises the capability to seamlessly handle Voice, Web and Mobile Chat, Web Voice/Video, Email, Simple Messaging, Social Media, and Messaging channels using a single intelligent attribute-based call routing through a unified Agent Desktop.
Avaya Workspaces	Acts as an Out of Box Agent and Supervisor desktop application. It supports all features and controls necessary for agents to manage their contact availability states.
Avaya Analytics™	Provides next-generation reporting and analytics designed to provide deep and broad insights across the solution.
Avaya Control Manager	Acts as a central management portal for administering of Agents, Users, Work Assignment Attributes, Hunt groups, Skills, VDNs, and Tenants.
Avaya Breeze® platform	Provides the platform for deploying the Avaya Breeze® platform components.

**Table 2: Avaya Aura® Core**

Component	Role
Avaya Aura® Communication Manager	Acts as a telephony application that connects to private and public telephone networks, Ethernet LANs, and the Internet. Communication Manager organizes and routes voice, data, image, and video transmissions.
Avaya Aura® System Manager	Acts as a central management system that provides a set of shared management services and software management solutions to support deployments, migrations, upgrades, and updates to the suite of Avaya Aura® applications.

*Table continues...*

Component	Role
Avaya Aura® Session Manager	Acts as a SIP routing tool that integrates all SIP devices across the enterprise network.  To simplify the existing communication infrastructure, Session Manager combines the existing communication infrastructure by combining existing PBXs and other communications systems, regardless of the vendor, into a cohesive, centrally managed, SIP-based communications network.
Avaya Aura® Call Center Elite	Forms the core part of the solution and provides voice capabilities for Avaya Oceana®. Avaya Oceana® leverages Elite features such as RONA, Observe, and Calendaring.
Avaya Aura® Application Enablement Services	Leverages the capabilities of Communication Manager and provides an enhanced set of Application Programming Interfaces, protocols, and web services to corporate application developers, third-party independent software vendors, and system integrators.
Avaya Workforce Engagement	Provides many services that can be installed on single or multiple servers. Each of these services is defined as a server role. For example, Contact Database, Framework Applications, and Avaya Contact Recorder server role.
Avaya Workforce Engagement Select	Works with Avaya Oceana® to provide call recording features of Avaya Workforce Engagement Select.

**Table 3: Clusters**

Component	Role
Avaya Oceana® Cluster 1	
Unified Collaboration Administration	Stores the configuration information entered in Avaya Control Manager and makes this information available to the other multicenter applications as required. The configuration information used by Unified Collaboration Administration consists primarily of the resources, that is, agents, and is managed by Avaya Oceana®.
Unified Collaboration Model	Acts as a central point of normalized resource and work state in Avaya Oceana®. Work refers to interactions such as inbound voice calls and web chats.
Call Server Connector	Acts as an interface between Communication Manager and the Avaya Oceana® application tier. It maintains the state of Unified Collaboration Model for all agents and stations registered on Communication Manager.
Avaya Work Assignment	Acts as an enterprise-wide Matching Engine for Avaya Oceana®. It matches the request with the most suitable resource available.

*Table continues...*

Component	Role
Avaya Context Store	Acts as a Memory Data Grid that can store contextual information provided by the customer's Enterprise Applications. These applications route data and historical data to be shared between Experience Portal, Engagement Designer, Work Assignment, and the multimedia Snap-Ins such as chat and email. These components also display customer data to Agents and show historical Journey information.
Avaya Engagement Designer	Acts as the business workflow execution engine of Avaya Oceana®. All interaction types, such as voice, email, and chat, start an Engagement Designer workflow.
Avaya Oceana® Cluster 2	
Unified Agent Controller	Acts as a server-side component that manages the connections to the individual agent desktops. It has access to agent configuration that is made available to the Unified Agent Controller component.
Avaya Mobile Communications	Integrates the Web Voice/Web Video capability provided by Avaya Aura® Web Gateway into Avaya Oceana®. Avaya Mobile Communications supports attribute-based routing of WebRTC calls made through customer mobile and web applications.
Avaya BotConnector Snap-in	Acts as an interface for the automation of short messages from a chat provider by acting as a proxy to the API of the Avaya Automated Chat server.
Avaya Oceana® Cluster 3	
Omnichannel Provider	Provides the option to add additional media to an established interaction. It includes Email, Chat, SMS, Social Media, Messaging, and Outbound.
Avaya Oceana® Cluster 4	
Avaya Co-Browsing Snap-in	Provides web collaboration between two users. Customers and agents can then jointly browse web pages and complete web forms.
Avaya Oceana® Cluster 5	
Avaya CRMGateway Snap-in	Provides a normalized access layer between Avaya Oceana® and Customer Relationship Management (CRM) systems of customers.
ZangSmsConnector Snap-in	Provides SMS support using ZangSmsConnector Snap-in. Use Avaya Oceana® Cluster 5 for Avaya Oceana® footprints with more than 100 agents.

**Table 4: Voice Self Service**

Component	Role
Avaya Experience Portal	Provides the front-end self-service application for the segment of Avaya Oceana® incoming calls.

*Table continues...*

Component	Role
Orchestration Designer	Creates applications for Avaya Experience Portal.
Avaya Proactive Outreach Manager	Provides the Outbound voice capability to Avaya Oceana®.

**Table 5: WebRTC Components**

Component	Role
Avaya Aura® Web Gateway	Acts as a WebRTC Signaling Gateway.
Avaya Aura® Device Services	Used for WebRTC Agent registration.
Avaya Aura® Media Server	Used for WebRTC media.  Performs all multimedia processing using the software. Media Server works with media gateways to provide a streamlined voice and data network throughout the enterprise.

---

## Accessing the Compatibility Matrix

### About this task

The Compatibility Matrix provides compatibility information for the Avaya products that are supported with the various releases of Avaya Oceana®.

### Procedure

1. Access the Compatibility Matrix page at <https://support.avaya.com/CompatibilityMatrix/Index.aspx>.
2. From the list of products, select **Oceana® Solution**.
3. Select the release number applicable to your solution.
4. When the page refreshes, scroll to the bottom of the page and select the appropriate release from the **Release** menu.

The Compatibility Matrix lists the compatible Avaya products and their versions.

# Chapter 5: Features

---

## Avaya Oceana<sup>®</sup> features

---

### Attribute-based routing

Avaya Oceana<sup>®</sup> provides attribute-based work and resource matching capabilities. Using Attributes, you can select the available resources and assign them to work or choose the waiting work and assign it to available resources. When selecting a resource to be assigned to incoming work, the resource must have the desired attributes specified in the work request. When selecting a waiting work request for a newly available resource, the work request must have attributes that match those from one unified pool of resources. In Avaya Oceana<sup>®</sup>, you must use Engagement Designer to create workflows that describe and run business processes used in your enterprise. A workflow defines a series of connected tasks required to complete a business process.

You must add your custom attribute to ensure that Work Assignment assigns appropriate resources to your chat requests during the testing. Work Assignment maintains all resources across the enterprise in a single pool and assigns work using a single universal matching engine and attributes-driven routing.

Work Assignment is deployed and configured as a snap-in on the Avaya Breeze<sup>®</sup> platform. Avaya Control Manager provides the administration user interface for Work Assignment, and Engagement Designer provides the overall flow logic. However, the use of Engagement Designer is optional. To provide a flow logic for Work Assignment, you can use a tool of your choice.

Work Assignment offers the following functionality:

- Match resources to incoming requests based on attributes.
- Match work to one resource at a time to find the most suitable resource for the requested work.
- Match work to several homogenous resources, as specified in the work request.
- Match work to a group of heterogeneous resources.
- Match work to a resource in a work surplus situation.
- Reject a resource.
- Retrieve metrics associated with a set of attributes.
- Configure agents with different proficiency levels.

- Prevent agents from avoiding work.

---

## Authorized access to Avaya Oceana® transcripts

In Avaya Oceana®, Omnichannel supports authentication and authorization for all the internal APIs that are used by various applications within the solution to access the conversation data. Only authenticated clients can access all previous Chat, SMS, Social, Messaging, and Email transcripts, including attachments.

To have authorized access to Oceana transcripts, you must configure the Authorization Service address and Tokenless access fields in System Manager. Avaya Workspaces users can use these tokens to access Oceana transcripts.

---

## Automated migration process

Avaya Oceana® supports an automated migration process. You can run the automated script to upgrade Avaya Breeze® platform nodes and the services of Avaya Oceana® clusters. Administrators can use simple script commands to migrate the Avaya Breeze® platform and Avaya Oceana® components to the latest release.

The automated migration script also supports ZangSmsConnector and CRMGateway snap-ins of Avaya Oceana® Cluster 5 and the OceanaDataViewer snap-in of Avaya Oceana® Cluster 3.

---

## Avaya Aura® Web Gateway support

Avaya Oceana® supports Avaya Aura® Web Gateway for Web Voice and Web Video calls. The Avaya Aura® Web Gateway server acts as a gateway to Avaya Aura® clients and applications utilizing WebRTC signaling and media. In Avaya Oceana® deployment, you can deploy the Avaya Aura® Web Gateway through Amazon Web Services (AWS) or VMware.

---

## Avaya Workforce Engagement Select integration

Avaya Workforce Engagement Select integrates with Avaya Oceana® so that Avaya Workspaces supervisors or agents can access the call recording features of Avaya Workforce Engagement Select.

For information about how to deploy Avaya Workforce Engagement Select and integrate it with Avaya Oceana®, see *Deploying Avaya Workforce Engagement Select with Avaya Aura® Communication Manager and Avaya Oceana®*, available from the Avaya Support website at <https://support.avaya.com>.

---

## Callback Assist

Avaya Oceana® provides callback functionality. If Avaya Oceana® does not find an available agent during a voice call, the caller is presented with the option to leave a voicemail or request a callback. If the caller selects the callback option, the caller is dropped from the call, and Callback Assist makes a new media-less call to Avaya Oceana® for routing to a suitable agent. After the agent answers the call, the customer is dialed and connected to the agent.

Callback Assist integrates with Avaya Oceana® at the callback state. Instead of bridging Callback Assist and Experience Portal into the call throughout, Callback Assist integration occurs within the Treatment vector.

Calls are initially front-ended and then transferred to Call Center Elite for assisted service. If no agent is available, calls are given advanced wait treatment using Communication Manager vectoring. Callers are periodically presented with the option to leave a voicemail or request a callback. After a caller selects the callback option, the call is routed to Callback Assist, where Immediate or Scheduled callback options are selected, and the call is dropped.

For the Immediate callback option, Callback Assist makes a new media-less call to Avaya Oceana® for routing to a suitable agent. After the agent answers the call, Callback Assist dials the customer number and connects the call to an agent.

The callback call from Callback Assist must not receive any media treatment while awaiting an agent. If media is accidentally provided, it establishes a SIP dialog, and Callback Assist treats this as an agent answer. Therefore, you must configure a No Media treatment vector. The No Media treatment VDN is used when the incoming call is a callback, instead of to a regular customer call.

From the agent and customer, the first party whom Callback Assist must call depends on an install-time option that cannot be changed through configuration. You can change this option only through an upgrade.

Callback Assist currently supports PSTN Voice but does not support Web Voice and Web Video.

The following diagram depicts the Callback Assist flow:

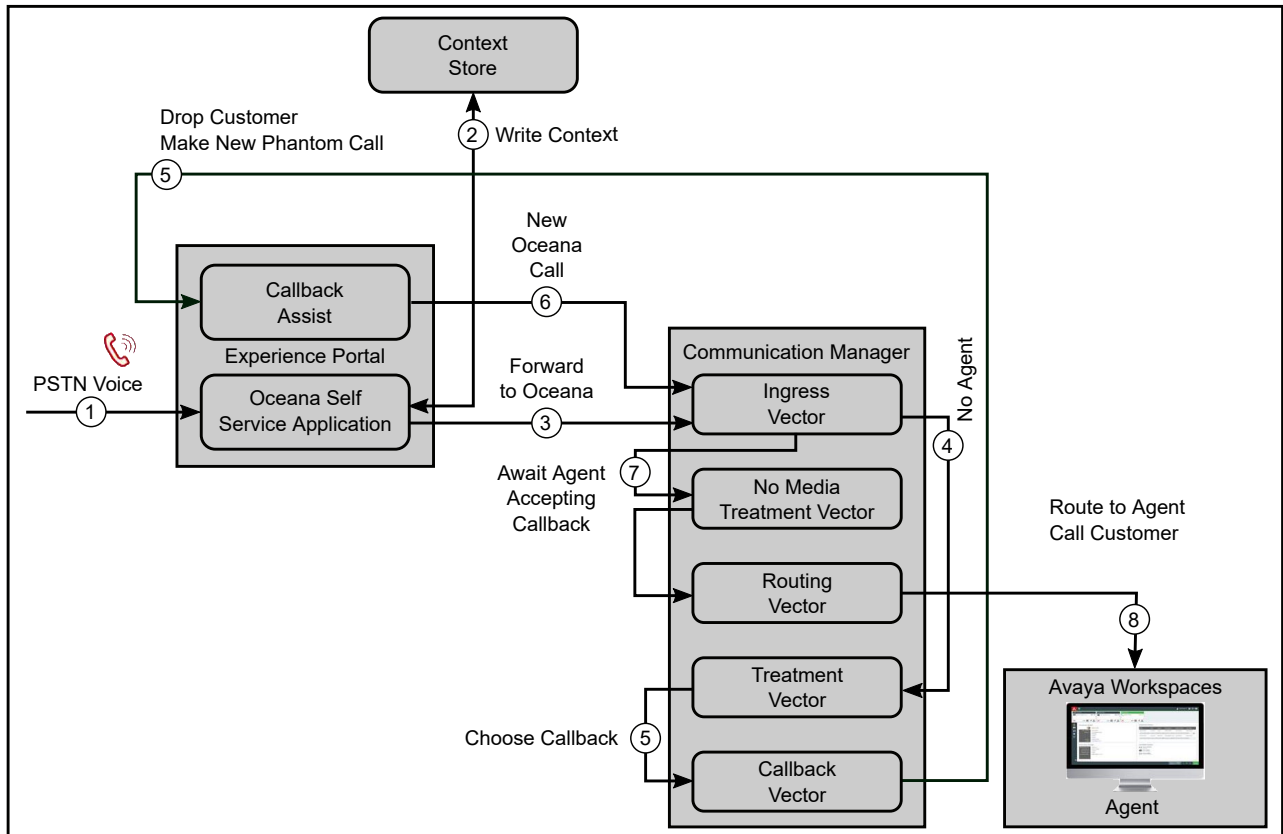

For more information about how to configure Avaya Oceana® and Callback Assist integration, see *Deploying Avaya Oceana®*, available from the Avaya Support website at <https://support.avaya.com>.

## Centralized logging

Avaya Oceana® supports the centralized logging feature. With this feature, you can view the logs for all services of Avaya Oceana® clusters through a centralized interface. It is an important and useful feature for a large solution like Avaya Oceana® where collecting large log data is complex and affects network utilization.

Avaya Oceana® uses Avaya Breeze® platform for centralized logging using the ELK (Elasticsearch, Logstash, and Kibana) stack. With this feature, you can also view major inbound, outbound, and error events for all the services of the Avaya Oceana® clusters. You can use this feature to also view information such as CPU usage, memory, disk I/O, and network analysis.

Avaya Oceana® centralized logging works for both WebSphere and Gigaspaces containers. You can run centralized logging in secure mode by configuring WebSphere certificate for each node of the cluster that hosts CentralizedLoggingService. Logstash collects, parses, and stores the logs for future use, while Elasticsearch stores the data in JSON document format. The JSON files are then shipped to the central ELK server, and you can use Kibana to search and view the logs that Logstash indexes.

---

## Channel exclusivity

Avaya Oceana® supports the Channel exclusivity feature.

This feature supports the following:

- Assign work to agents on another channel when required by the business. For example, when voice agents are busy, Avaya Oceana® can assign voice interactions to the available chat agents.
- Dedicate agents exclusively to a channel interactions.

This feature is applicable to agents and supervisors for all channels.

---

## Data access groups

Avaya Oceana® provides a data access control mechanism for agents and supervisors. Data access groups, also referred to as data partitioning, are created within Avaya Control Manager and assigned to agents to control the data that the agents can see within Avaya Workspaces.

By creating groups and assigning relevant entities to the groups, you can control data access across agents. You can create customer-defined data groups to restrict the data that agents can see within Avaya Workspaces while handling contacts. You can restrict agents from accessing data that is not relevant to their group or business unit.

You can assign the following Avaya Oceana managed entities to a group:

- Work codes
- Disposition codes
- User codes
- Defer codes
- Transfer services
- Screenpops
- Email template groups
- Outgoing mailboxes

An agent can access only those entities of a group that are assigned to the agent. You can create maximum 100 groups in Avaya Control Manager and can assign maximum five groups to a user. Users can access all the data in the system if:

- No groups are assigned to them.
- Groups assigned to them do not have a selection for a given entity type. For example, if a user is assigned to groups containing work codes and user codes, the user can access only the assigned work codes and user codes. On the other hand, the user can access all the disposition codes available in the system.

You can also edit and delete a group. While changes made to groups are reflected immediately to agents logged into Avaya Workspaces, deleting a parent group deletes the child groups.

**\* Note:**

- Groups are added within the context of the Avaya Control Manager location because locations are the virtual objects that form the core entity of the Avaya Control Manager environment.
- Data partitioning is not supported for rejection codes. There is no group management mechanism to enable different agents to see different rejection codes.

---

## Data redundancy and disaster recovery

Avaya Oceana® disaster recovery provides a planned approach to re-establish a critical service at a secondary data center when a complete outage occurs at the primary data center.

Avaya Oceana® supports disaster recovery in two failure modes:

- Unplanned complete data center outage
- Planned complete data center outage

Avaya Oceana® disaster recovery solution ensures that the servers on the remote geographic site maintain a near real time local copy of the active configuration databases and server configuration on the main site. In the case of a complete outage of the main data center, a customer is able to carry out a sequence of manual steps at the standby site to restore the Avaya Oceana® Contact Center service. The secondary site contains an up-to-date copy of the required administration and reporting data so that when the solution is restarted, the customer is able to continue business.

The *Avaya Oceana® and Avaya Analytics™ Disaster Recovery* document provides information on how to configure a geographically redundant Avaya Oceana® so that when a primary data center outage occurs, the redundant site can be made operational. The secondary site has an updated copy of the required administration and reporting data so that the operations are not affected.

The following diagram depicts the high-level architecture of Avaya Oceana® disaster recovery:

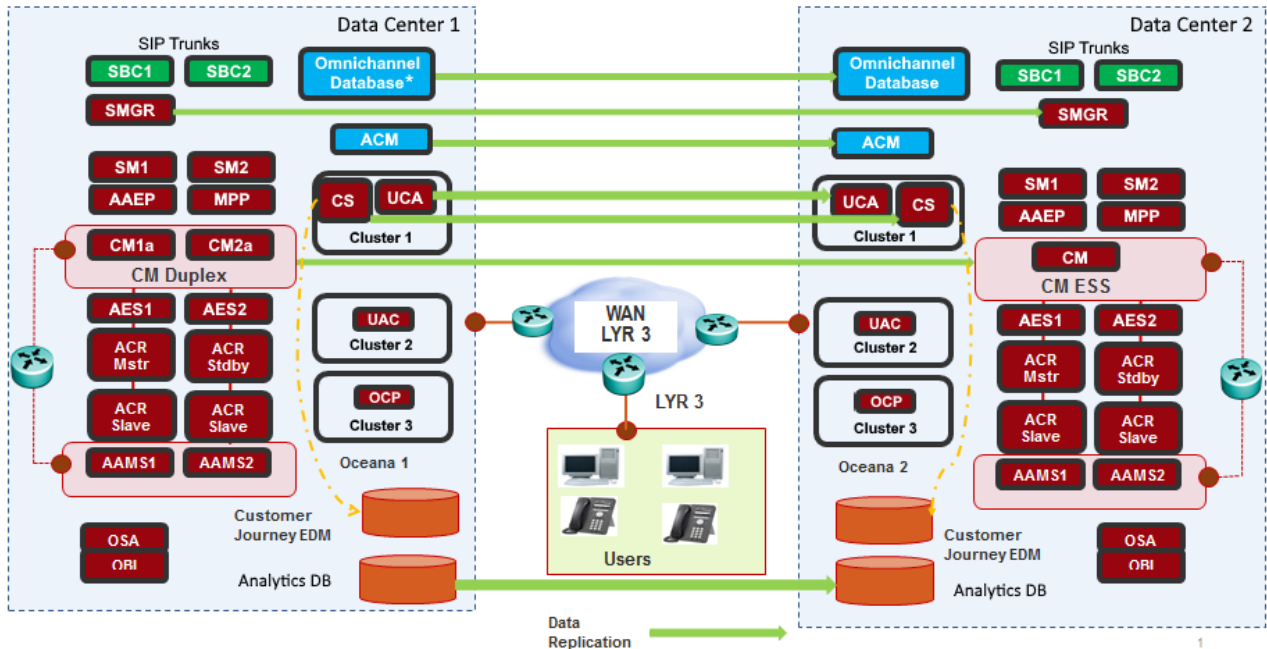

\* Data Center 1 can also have two Omnichannel Databases if you configure it for High Availability.

**\* Note:**

The primary data center is referred to as Data Center 1 and the secondary data center as Data Center 2.

The following components support data replication:

- Configuration data stored in UCA (Unified Collaboration Administration) including users, accounts, work assignment attributes, and attribute assignments
- Configuration data stored in the Omnichannel database
- Customer journey data in Avaya Context Store Snap-in
- Avaya Control Manager data stored in the SQL server database.
- Avaya Analytics™ reporting data

In the event of a total outage of the main site, the administrator follows a manual procedure to start both Avaya Oceana® or Avaya Analytics™ on the remote geographic site. Using the instance of Avaya Oceana® at one site and the instance of Avaya Analytics™ at the other site is not supported. Avaya Oceana® and Avaya Analytics™ must be running on the same site.

## Defer email

### Agent

Avaya Oceana® provides the defer email feature for agents. With this feature, an agent can defer an email for a specified number of hours.

## Supervisor

Avaya Oceana® provides the defer email feature for supervisors. With this feature, a supervisor can manage and defer emails if the agent is unavailable.

A supervisor can:

- Take ownership of the deferred email, complete the email, and send it to the customer.
- View the list of emails deferred by the agents in the team.
- Transfer the deferred email to another service.

Avaya Analytics™ reports on the count of deferred emails in both real-time and historical reports.

---

## Deployment modes

Avaya Oceana® includes Avaya Oceana® and Avaya Analytics™ and supports the on-premises deployment option.

- Avaya Oceana® can continue to be deployed on customer premises, as with previous versions of Avaya Oceana®.
- Avaya Oceana® supports the capability to deploy both the Avaya Oceana® and Avaya Analytics™ components in the customer sourced Amazon cloud environment. These are connected to Avaya Aura® stack and Avaya Aura® Call Center Elite voice solution which can be deployed on the customer premises.
- Customers can buy Avaya Oceana® as perpetual or on subscription and they can choose to deploy the solution on-premises.

---

## Export and import of multiple workflows

Avaya Oceana® provides an option to export and import multiple workflows. To move workflows from one server to another server, you can select multiple workflows, export them to a file, and import them back to another server.

---

## External transcript access

Avaya Oceana® supports pushing transcripts to a defined customer location. With this feature, customers can access email and messaging transcripts after a contact is closed.

For messaging transcripts such as Chat, SMS, Social Media, and Messaging, Avaya Oceana® enables a filtering service to remove sensitive data, such as credit card details before they are persisted to the database.

You can download the sample client and documentation from the DevConnect portal at <https://www.avaya.com/devconnect.com>.

## High availability and cache mirroring

Avaya Oceana® provides the Campus High Availability (HA) functionality. Using this functionality, Avaya Oceana® can automatically recover from a single point of failure.

**\* Note:**

In this chapter, the terms virtual machine and node refer to a virtual server that hosts Avaya Breeze® platform.

This functionality provides mitigation for the following failure scenarios:

- A single Avaya Oceana® process outage at a time
- A single virtual machine outage at a time
- A single physical server outage at a time
- A single network link outage at a time

The advantages of Avaya Oceana® HA are:

- Processes new contacts after the outage.
- Agents and supervisors can operate after the outage.

The following table lists the concepts used in Avaya Oceana® HA:

**Table 6: High availability concepts**

Concept	Description
Failure Event	Specifies one of the following single failure scenarios: <ul style="list-style-type: none"> <li>• Failure of a single process</li> <li>• Failure of a single virtual machine</li> <li>• Failure of a single physical server</li> <li>• Failure of both network links to a virtual machine</li> <li>• Failure of all network links to a single physical server.</li> </ul>

*Table continues...*

Concept	Description
Network Failure	<p>Specifies one of the following network failures:</p> <ul style="list-style-type: none"> <li>• Failure of all network links to a virtual machine. For example, the failure of a virtual network adaptor on a virtual machine isolates the virtual machine from the network.</li> <li>• Failure of all network links to a single physical server. For example, the failure of all network adaptors on a physical server isolates the physical server from the network.</li> </ul> <p>Avaya Oceana® does not detect the network latency directly. Avaya Breeze® platform detects all severe network issues and triggers a failover of the virtual machine or process. When a network failure isolates a virtual machine or a physical server from the network, manual intervention is required before the virtual machine or the physical server reconnects to the network.</p> <p>When a network failure isolates a virtual machine or a physical server from the network, Avaya Oceana® identifies and shuts down WAS and GigaSpaces on the isolated virtual machine or physical server.</p>
Process Failure	<p>Specifies the failure of a single process in Avaya Oceana®.</p> <p>For example, the failure of the WebSphere Application Server process or a GigaSpaces PU instance.</p>
Server Failure	<p>Specifies the failure of a single virtual machine or a single physical server. This failure implies that all process instances within the virtual machine or the physical server are lost.</p>

Avaya Oceana® only supports a single failure event. Therefore, if two simultaneous failure events occur, Avaya Oceana® components can not operate in HA mode.

Avaya Oceana® supports HA in the following failure scenarios:

- Network failure on the physical server hosting the Avaya Oceana® Cluster 3 - Avaya Breeze® platform node (Active Load Balancer) and Active Omnichannel Database
- Power failure on the physical server hosting the Avaya Oceana® Cluster 3 - Avaya Breeze® platform node (Active Load Balancer) and Active Omnichannel Database
- Network failure on the physical server hosting the Avaya Oceana® Cluster 1 - Avaya Breeze® platform node (Active Load Balancer and Database), Active Application Enablement Services, and Active Communication Manager
- Power failure on the physical server hosting the Avaya Oceana® Cluster 1 - Avaya Breeze® platform node (Active Load Balancer and Database), Active Application Enablement Services, and Active Communication Manager

### Campus High Availability

Avaya Oceana® offers Campus High Availability (HA) from a single failure event. The main features of Campus HA are:

- Capacity is maintained for a single failure in the system.

- Service availability of new contacts arriving into Avaya Oceana<sup>®</sup>. Service to existing contacts in progress can be affected depending on failure.
- Coverage for system outage scenarios. Note that some network outage scenarios do not provide HA.
- Leveraging Avaya Control Manager HA and Avaya Analytics<sup>™</sup> HA capabilities. Deployment of HA for Avaya Control Manager and Avaya Analytics<sup>™</sup> 3.x is optional, the architecture for Avaya Analytics<sup>™</sup> 3.x provides HA by default.

**\* Note:**

If an Avaya Breeze<sup>®</sup> platform node fails, you must schedule a maintenance window to reboot the affected cluster after you recover the failed node.

### Cache Mirroring

Avaya Oceana<sup>®</sup> provides Cache Mirroring configuration for a reliable infrastructure. You can keep the active and standby multichannel Database servers in one data center and the backup multichannel Database server in another data center.

Omnichannel Database utilizes the Cache mirroring feature for Campus HA. A mirror can provide HA through automatic failover where a failure of the Cache instance causes the other instance to take over automatically.

All Omnichannel Database clients connect to the active mirror through a Virtual IP address, which is always bound to an interface on the currently active database.

When you configure Omnichannel Database, you can do data mirroring with one of the following:

- HA active and standby Omnichannel Database servers within one Avaya Oceana<sup>®</sup> site (Data Center 1) with automatic failover  
In this configuration, you do not have a geo-redundant backup.
- Active Omnichannel Database server in Data Center 1 and Geo backup Omnichannel Database server in the geo-redundant site (Data Center 2) with no automatic failover
- HA active and standby Omnichannel Database servers within Data Center 1 with automatic failover and Geo backup Omnichannel Database server in Data Center 2 with no automatic failover

In Omnichannel Database HA, Omnichannel Database:

- Records the transcripts of Chat, Email, SMS, Messaging, and Social sessions for Customer History at the end of the interaction.
- Requires its deployment in an active-standby configuration on separate physical servers in the same subnet with a Round Trip Time (RTT) less than 120ms.
- Automatically switches over to the standby server during outage of the active server or lack of communication from the active server. After the switchover, the standby server becomes the active server.

Data on the standby server remains updated in real time.

---

## Integration of Avaya Workforce Engagement Select with Avaya Oceana®

Avaya Workforce Engagement Select integrates with Avaya Oceana®, so that Avaya Workspaces supervisors or agents can access the call recording features of Avaya Workforce Engagement Select.

Avaya Workspaces displays Avaya Workforce Engagement Select widgets to provide controls to playback, start, pause, and resume recording of an in-progress interaction. The integration also provides features such as multichannel recording, live monitoring, quality management, and performance management.

---

## Integration of Watson adaptor for custom chatbot

Watson Adaptor is an adaptor plug-in deployed with the BotConnector. The Watson integration feature provides improved integration with Oceana Chat for custom chatbot functionality and provides:

- The Watson adaptor to customize the virtual Agent sender name for all chatbot messages.
- Ability to reconnect to the existing chat session after a page refresh or navigation.
- Allows a chat session to continue as a consumer navigates the customer website.
- Ability to disable default escalation methods such as Timeout, and Max Messages. This gives the Watson adaptor full control over when escalation occurs.

You can achieve integration by extending the existing APIs and deploying a custom chatbot adaptor with Oceana. There is no out of the box functionality delivered with this feature. Custom development on the chatbot adaptor, and chat client is required to integrate the chatbot.

The API extension provides the ability to pass custom data between chatbot adaptor and customer chat client, enabling development of custom chatbot features such as menu driven chat. Custom data are provided to the desktop client after escalation and is available for custom widgets.

---

## Customer Journey and visualization

Avaya Oceana® maps customer journey across various self-service and assisted service channels by storing related data. Agents and supervisors can use Avaya Workspaces to view a visual representation of a customer's interactions. Every point in the customer journey is visualized by an interaction with a channel, such as Voice, Video, Email, SMS, Chat, Social Media, or Messaging. Data on the agent desktop also includes a 360 degree view of the customer journey across all channels to facilitate informed decisions.

Context Store's journey data, when stored in the Journey PU, can be used to produce a visualization of a Customer's journey. The Journey PU stores the data required to build Customer

Journey View in Avaya Workspaces. The details displayed as part of the customer journey include:

- Journey start time
- Journey end time
- Journey interaction point
- Number of interactions

Avaya Oceana® supports viewing Customer Journey in Avaya Workspaces by topic. A topic is an identifier that you can use to correlate intent across multiple channels. For example, a customer enquiry about an insurance claim can traverse across multiple media channels. Topics can unify those interactions in the customer journey. If no topic value exists when a contact is created, a default value is provided. The default value is a combination of the Language and Service attributes, which demonstrates how to link cross-channel interactions that arrived for a topic. The default value can only be provided if Language and Service attribute values exist.

Avaya Workspaces provides a graphical representation of the end-to-end journey of the customer in the following views:

- Default view: Displays one interaction per work request.  
Drill-down view: Displays detailed information, including all status changes, for the selected journey element. All relevant data and links are presented in this view. The most recent information is displayed at the top of the vertical timeline.
- Topic view: Displays a filtered view of all the journey elements associated with the selected topic.
- Account View: Displays a filtered view of all journey elements associated with the selected account.

Avaya Oceana® also supports the Customer Journey feature for Outbound contacts. You must add the Customer Journey widget for Outbound agents so that they can view Customer Journey in Avaya Workspaces.

### **Oceana Customer Management Tool**

Avaya Oceana® supports Oceana Customer Management Tool (OCMT), which is an application to manually add customer data. You can also use this application to import customer data from an external source into Avaya Oceana®. In a single import, OCMT limits you to import data of 20000 customers in Avaya Oceana®. However, you can import new sets of customers by repeatedly using OCMT. You can open OCMT using the Avaya Control Manager web interface.

### **Avaya CRMGateway snap-in support to link CRM details to Omnistore**

Avaya Oceana® supports the Avaya CRMGateway snap-in, which allows Avaya Oceana® to communicate with third-party Customer Relationship Management (CRM) systems. Customers can use Avaya CRMGateway SDK to develop adapters to fetch customer data from a customer CRM. The Avaya CRMGateway snap-in is required in Avaya Oceana® to facilitate the customer use-case functionality, where customer records are too large for importing to the Omnistore database, the Avaya Oceana® customer database.

With Avaya CRMGateway snap-in, you can continue to manage the customer details primarily in the external CRM. You can then configure the Omnistore database to enable the retrieval of customer history and customer journey data that is stored within Avaya Oceana® for the customer.

When Avaya Oceana® is integrated through the CRM Gateway to any third party CRM using custom software, the following customer details can be retrieved from the CRM for a single unique customer:

- First and last name
- Address
- ZIP code
- CRMID
- AccountID
- One custom field

These details are stored in Omnistore Database and displayed in the Customer Details widget in Avaya Workspaces.

If multiple values of the above parameters are returned from the CRM, only the first value for each parameter is added to the Omnistore database. The CRM matches a unique customer. If multiple customer records are returned for a phone number or email address, the data returned is discarded by Avaya Oceana® and is not added to the Omnistore database.

Using the Avaya CRMGateway snap-in, you get a view of the customer details from the CRM directly, while doing a customer search on the CRM. The Avaya Customer Management snap-in fetches data from the CRM and stores this data or a part of this data in the Omnistore database.

---

## Messaging channel

Avaya Oceana® supports the Messaging channel. With this channel, a customer can use WhatsApp, Twitter, Facebook Messenger, or a custom chat-like interface to engage with a contact center agent over an extended period. The communication between the customer and agent does not require live availability of either of them.

---

## Multichannel support

Avaya Oceana® provides multichannel support that extends across all digital channels and devices to improve the overall customer and agent experience. Agents get a seamless and consistent experience across these channels of interactions to implement a complete actionable customer journey. The Avaya Oceana® supported channels are:

### Voice

A customer service channel where customers request support through voice. This includes PSTN Voice and Web Voice. In Avaya Oceana®, voice capabilities are delivered through a Call Center Elite voice feature known as Adjunct Route.

Voice calls are routed to Avaya Oceana® agents. Routing of voice contacts can be split between standard Call Center Elite skill based routing and Avaya Oceana® attribute based routing as follows:

Calls to be handled by skills-based routing queues to the existing Call Center Elite skills.

- Call Center Elite agents handling skills-based calls use their existing telephone such as, 9600 Series IP Deskphones and existing desktop such as, Avaya one-X® Agent, Avaya IC client, and Avaya Aura® Call Center Elite Multichannel desktop.
- Call Center Elite supervisors use Avaya Call Management System for real time and historical reports.

Calls to be handled by Avaya Oceana® attribute-based routing goes to a Call Center Elite Call Vector for Avaya Oceana® calls.

- Call Vector provides wait treatment.
- Call Vector makes an Adjunct Route request to Avaya Oceana®, which responds with a Direct Agent ID. This means Oceana® selects the best agent based on caller context and need, and the vector routes to that agent.
- Avaya Oceana® agents handling attribute-based calls uses Avaya Workspaces for call control and their existing telephone such as 9600 Series IP Deskphones to receive the audio.
- Add agent initiated co-browse to an existing voice session – when in a voice call with a customer, the agent can opt to start a co-browse session with that customer.
- Avaya Oceana® supervisors use Avaya Analytics™ for real time and historical reports.

### Chat

A customer service channel that supports chat communication embedded within a website or a mobile application. Avaya Oceana® supports end-to-end web chat. This channel can include BotConnector for automation that requires additional Avaya Automated Chat Service subscription, or you can use third-party Chat engines. Using BotConnector allows customers to address repeat or simple engagements with an automated response. Customers using this option can see increased efficiency in their contact center operations by allowing some interactions to be handled without agent involvement. Customers must write their own adapters to use third-party Chat engines.

Chat messages are routed to Avaya Oceana® agents.

### Email

A customer service channel where customers request support through emails set by the company. Avaya Oceana® email capabilities offer replies that can be sent directly to the customer through auto-acknowledgements or delivered to agents as suggested responses for their review before sending. Avaya Workspaces presents users with basic email functionality to allow easy responses to customer emails. Avaya Oceana® supports POP3 and IMAP for email retrieval.

Emails are routed to Avaya Oceana® agents.

#### Important:

Short Pointless Annoying Messages (SPAM) are unsolicited, indiscriminate, or junk emails. You must install and actively manage a SPAM filter to remove SPAM messages from all contact center mailboxes. If you do not filter unsolicited bulk SPAM messages in Avaya

Oceana®, they can impact the performance or can cause damage to your contact center solution. Do not use the Avaya Oceana® Email Service as a SPAM filtering tool.

Avaya Oceana® Email Service does not support Email Source Routes. This email format is outdated. Configure Avaya Oceana® Email Service to treat the Source Routes emails as SPAM messages. Do not address the Source Routes emails to the mailboxes monitored by Avaya Oceana® Email Service.

## SMS

A distinct interaction type in Avaya Oceana®. SMS messages fall between chat and email in terms of urgency. SMS messages are handled through chat UX. From reporting perspective, SMS are treated as a channel.

SMSs are routed to Avaya Oceana® agents. This can include BotConnector before routing to the agent.

To support SMS, Avaya provides the following two options:

- ZangSmsConnector Snap-in: To support Inbound and Outbound messaging through Avaya Oceana®.
- SMSVendorSnapin: To test SMS functionality without having to use a physical handset. SMSVendorSnapin uses the same REST messages that any third-party uses. It does not use live SMS traffic. It simulates sending new messages in to the Contact Center and logs the responses instead of sending them to customer numbers.

## Social Media

A customer service channel where customers can route, report, and present social interactions to agents by using Avaya Workspaces. Integration with Avaya Messaging Automation provides connection to various social media platforms, such as Facebook and Twitter.

Social messages are routed to Avaya Oceana® agents. This can include BotConnector before routing to the agent.

## Messaging

A customer service channel that supports communication between the customer and agent over an extended period through WhatsApp or a custom chat-like interface. The communication between the customer and agent does not require live availability of either of them. Organizations can enable Messaging in their applications for a customer to submit queries. After submitting the queries, the customer can close the application. The customer does not have to wait for an immediate response. When an agent provides a response, the device notification alerts the customer about the response from the agent. When the customer opens the application, the application shows the conversation and enables the conversation to continue seamlessly.

Conversations done through the Messaging channel contain many engagements over an extended period. The full conversation remains visible to all participants. Messaging conversations are currently supported through In App Messaging, Facebook Messenger, Twitter DM, and WhatsApp.

The Messaging channel supports sharing of rich-media content such as images, carousels, and list pickers, and location requests. Therefore, Avaya Workspaces includes a new and custom widget to support rich-media content.

Messaging interactions are routed to Avaya Oceana® agents.

## Video

A customer service channel where customers request support through video. Avaya Oceana® supports WebRTC video both as an incoming channel for routing and agent selection. It enables customers to contact the enterprise from a Chrome browser while browsing their website or from within their smartphone iOS and Android applications. Note that other browsers are not supported in this channel of interaction.

Currently, an agent configured to receive video can also support or enabled to support voice channel (PSTN or WebRTC).

Video calls are routed to Avaya Oceana® agents.

---

## Oceana Data Viewer

Avaya Oceana® includes the Oceana Data Viewer service that acts as a debugging and visualization tool for Avaya Oceana®. With this tool, you can view the Chat, Email, SMS, Social, Messaging, and Generic contacts that are in Omnichannel Database.

---

## Post Call Survey

Avaya Oceana® provides the Post Call Survey feature. With this feature, the caller can provide a rating based on the interaction with the agent.

Using this feature, Avaya Oceana® can connect with an external survey application to solicit feedback from a customer after the customer completes the call with an agent. This feature builds on the VDN Return Destination feature of Communication Manager to first direct the calls to a Survey Vector Directory Number (VDN) and then to an application such as Experience Portal.

When Communication Manager detects that the agent is dropped from a voice call, the customer is kept connected and is directed the configured survey application. Calls that terminate in coverage or callback must not connect to the survey application. Therefore, you must carefully administer the Vector Return Destination (VRD).

Avaya Oceana® provides a sample Experience Portal application named OceanaSurvey. This application is intended to demonstrate how to retrieve the following details to the customer:

- Account ID
- Agent ID of the agent who interacted with the contact
- Disposition of the contact

The caller is prompted for a rating from 0 to 9. This rating is stored in the customer's journey along with the other context from the call.

The following diagram depicts the Post Call Survey flow:

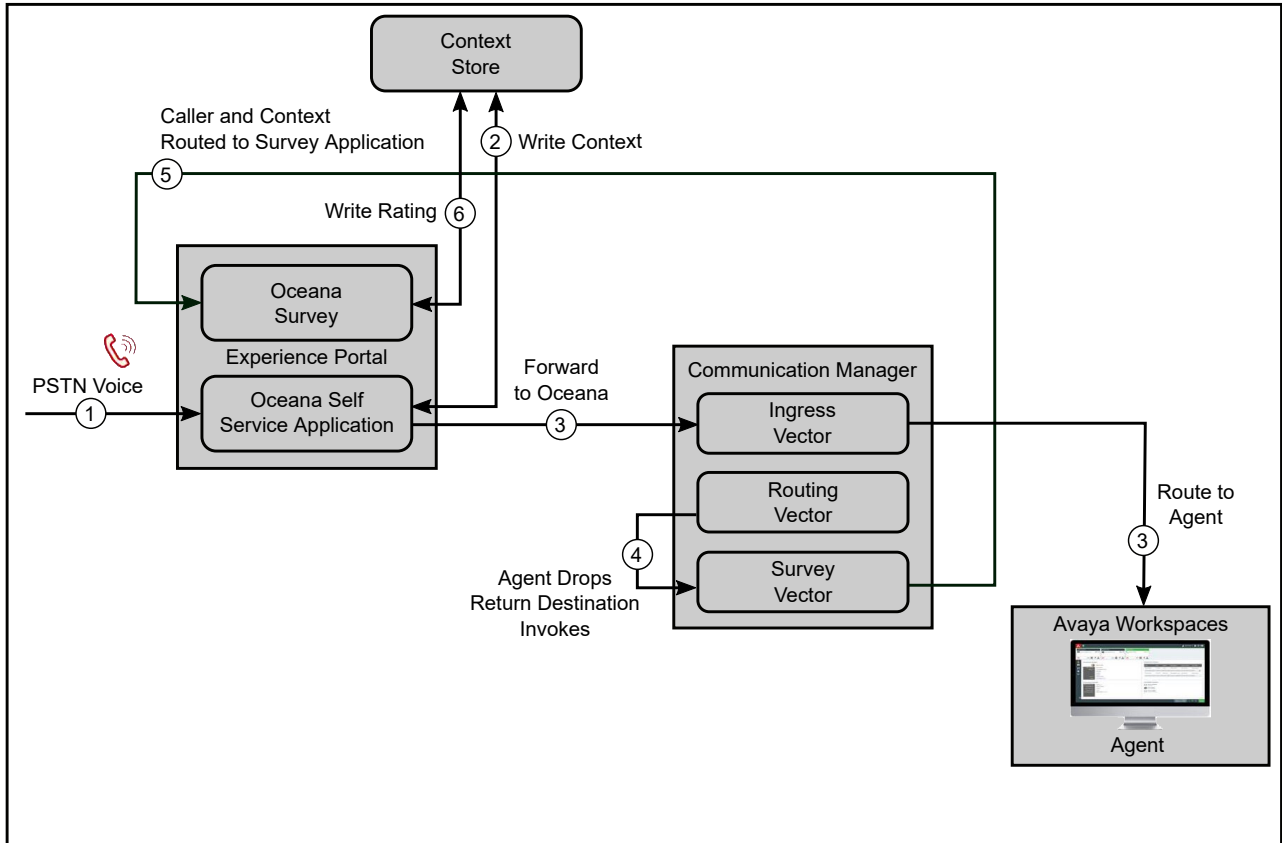

When you configure this feature, you must correctly configure the Allow VDN Override parameter to ensure that callers get the survey at the right instances. For example, it is not desirable to provide a survey to a customer who has requested a callback without having spoken to an agent.

VDN Override is a Communication Manager Call Center Elite feature that allows information of the subsequent VDN where a call is routed, instead of the information of the previously-active VDN. If a VDN is configured with the Allow VDN Override parameter as no, it maintains ownership of the call throughout the routing process. Therefore, when the agent receives the call, all call data is transferred to this VDN.

The following configuration supplies a post call survey to the caller in the following situations:

Survey Applied	Vector	Comment
Yes	Ingress > Routing	Agent surplus
Yes	Ingress > Treatment > Routing	Call surplus
No	Ingress > Treatment > Callback	Caller requests callback
No	Ingress > Treatment > Coverage	Caller chooses to leave a voicemail
No	Ingress > Fallback	Routing error occurred or Avaya Oceana® out-of-service
Yes	Ingress > Routing > Transfer > Routing	Call transfer, Agent surplus

Table continues...

Survey Applied	Vector	Comment
Yes	Ingress > Routing > Transfer > Treatment > Routing	Call transfer, Call surplus
No	Ingress > Routing > Transfer > Treatment > Callback	Call transfer and then callback
No	Ingress > Routing > Transfer > Treatment > Coverage	Call transfer and then voicemail
RONA not shown	-	At any point, RONA follows the above rules

You must configure the Allow VDN Override and Return Destination parameters for Avaya Oceana® VDNs as follows:

VDN	Allow VDN Override	Return Destination
Ingress	Y	Not Set
Treatment	Y	Not Set
NoMedia	Y	Not Set
Routing	Y	Set to Survey VDN
RONA	Y	Not Set
Transfer	Y	Not Set
Fallback	N	Not Set
Callback	N	Not Set
Coverage	N	Not Set
Survey	N	Not Set

**\* Note:**

If survey is not required, Avaya recommends that you configure the Allow VDN Override parameters according to this table. However, the Return Destination parameter on the Routing vector can be omitted. With this configuration, customers can quickly enable or disable survey using a single setting.

For more information about how to configure Avaya Oceana® and Post Call Survey integration, see *Deploying Avaya Oceana®*, available from the Avaya Support website at <https://support.avaya.com>.

---

## Remote workers

Avaya Oceana® supports the remote worker functionality for Web Voice and Multimedia channels. With this functionality, remote agents or supervisors who are physically not located in the contact center infrastructure can access Avaya Oceana® and Avaya Analytics™ applications and perform their tasks.

## Second Chance Interactive Voice Response

Avaya Oceana® provides the ability to traverse self-service a second time, after being answered by an agent. The agent does a single-step CTI-transfer of the callback to Experience Portal Self-Service Application, passing the context of the original call in the UUI. The logic of the application does not detect the call as a brand new inbound call and reuses the context of the current call. The application skips the Customer ID&V prompt and requests the routing service.

The Customer Management step is also omitted because the customer is already known. Any adjustments to the routing service or any other customer context are made in Oceana Core Data Service (OCDS) and the call is presented to a suitable agent. The application tags this call using a T identifier to distinguish from regular inbound calls, and the workflow includes the bespoke logic to terminate the original workflow based on this tag.

## Second Chance IVR flow

The following diagram depicts the Second Chance IVR flow:

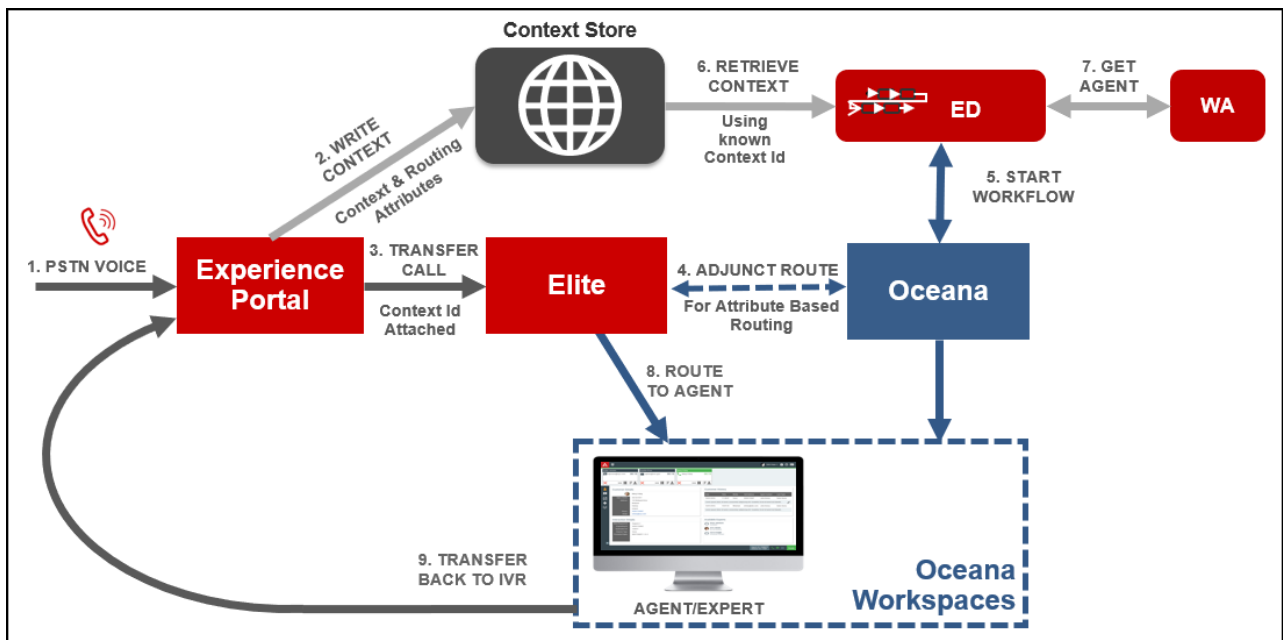

## Limitations of Second Chance IVR

The following are the limitations of the Second Chance IVR:

- Only supports single-step transfer
- Only supports PSTN Voice to a PSTN Voice agent

No support for Web Voice, Web Video, or PSTN Voice to a Browser-only agent.

- Requires Communication Manager and Application Enablement Services 7.1.3, 8.0, or later version to ensure the retention of UUI data on a CTI-initiated single step transfer

## Channel identifiers and contact dispositions

### Channel identifiers

The following table lists the valid channel identifiers in a context in the UUI:

Identifier	Description
VO	PSTN Voice
WV	Web Voice
VI	Video

### Contact dispositions

The following table lists the valid contact dispositions in a context in the UUI:

Disposition	Description
N	New call
E	Escalation
C	Callback
T	Transferred call

### Context format

The following is the format of a context in the UUI:

*<20 or 22 digit context id>, <2 digit channel identifier>, <1 digit contact disposition>*

For example, v6miVjRqTWqQJEF8fpRyLA,VO,N.

In this example:

- v6miVjRqTWqQJEF8fpRyLA specifies the context ID.
- VO specifies the PSTN Voice channel.
- N specifies a new call.

## Second Chance Call Center Elite IVR

In Call Center Elite IVR, when the call traverses the Self Service vector for the second time, the vector overwrites *<length of customer id>* and *<length of menu selections>* with new menu selections. However, the rest of the Avaya Oceana® UUI data is not overwritten. The data looks corrupt, but it is usable.

For example:

- First time entering the Self Service flow  
UUI data (MenuSelections) = '12345623'
- First time leaving the Self Service flow  
UUI data (MenuSelections) = '19115007601548851045,VO,N'
- Second time entering the Self Service flow  
UUI data (MenuSelections) = '12345623601548851045,VO,N'

- Second time leaving the Self Service flow

UUI data (MenuSelections) = '19115007601548851045,VO,T'

**!** **Important:**

For Second Chance Call Center Elite IVR, the Collected Digits must be parsed out to ensure that none of the corrupt context is inadvertently stored. This logic parses out the first 8 digits that are entered using DTMF, and omits the rest. 8 must be adjusted upwards or downwards depending on the length of the account ID being used, and the number of menus in the IVR interview. For example, for a 4-digit account number, 8 must be changed to 6 (4 + 1 + 1).

## Second Chance Experience Portal IVR

In Experience Portal IVR, you must set the flag in UUI if this call is in IVR for the second time. You must use the Update Context task instead of the Create Context task because the customer is already known.

**!** **Important:**

For Second Chance Call Center Elite IVR, the Context ID must be parsed out from the incoming UUI data for later use in the Update Context task.

### Agent matching

If the Specified Resource feature is specified at the IVR front-end, then ResourceMap and ServiceMap are populated in the context. If this call is transferred back for Second Chance IVR, the front-end overwrites the ServiceMap with the new values, but leaves the ResourceMap unchanged. Therefore, the Assisted Service workflow matches against the specified resource from the original call.

If this is undesirable for a given customer, then the ResourceMap must be explicitly removed from the OCDS context. For example, in the Assisted Service flow or the front-end app, the default out-of-the-box flow or app does not clear the ResourceMap.

---

## SNMP alarming

Avaya Oceana® supports SNMP alarming for each Avaya Oceana® service by using Serviceability Agent.

**\* Note:**

Avaya Analytics™ does not use Serviceability Agent.

Serviceability Agent is an enhanced version of the SAL agent for forwarding logs, harvesting logs, and alarming. Serviceability Agent sends SNMPv3 traps and notifies the configured NMS destinations. System Manager and the SAL gateway are the two mandatory destinations.

Using the Serviceability Agent user interface you can:

- Manage and configure SNMPv3 users remotely
- Manage and configure SNMP trap destinations remotely

- Create, edit, view, and delete user and target profiles

---

## Avaya CRMGateway snap-in support

Avaya Oceana® provides support to Avaya CRMGateway snap-in which acts as a normalized access layer between Avaya Oceana® and the Customer Relationship Management (CRM)s of the respective customers through an adapter. Customers can use Avaya CRMGateway SDK to develop adapters to fetch customer data from a customer CRM.

The Avaya CRMGateway snap-in is required in Avaya Oceana® to facilitate the customer use-case functionality, where the customer records are too large for importing to the Omnistore database. With Avaya CRMGateway, you can continue to manage the customer details primarily in the external CRM. You can then create the necessary linkage in the Omnistore database to enable the retrieval of customer history and customer journey data that is stored within Avaya Oceana® for the customer.

Using Avaya CRMGateway snap-in, you get a view of the customer details from the CRM directly, while doing a customer search on the CRM. The Avaya Customer Management snap-in fetches data from the CRM and stores this data or a part of this data in the Omnistore database.

The Avaya CRMGateway snap-in is installed in Avaya Breeze® using the System Manager web console. All Avaya CRMGateway alarms are displayed in System Manager.

The serviceability attributes of the Avaya CRMGateway snap-in are as follows:

- Runs in a secure cluster
- Uses Avaya Oceana® Serviceability API to send messages and heartbeats
- Registers on the Avaya Oceana® Monitor page

Using Avaya CRMGateway, you can also get the customer details that contain all the identifying values. Agents can access the customer-identifying information and the system can identify the customer from the channel on which the interaction originates.

---

## Customer accounts management

Avaya Oceana® provides support for customer entered account data to enhance management of customer accounts. A customer account consists of the following components:

- Account type: The type of account associated with the customer for an interaction. For example, social security number, booking reference, support ticket, or subscription number. You must specify the account type in Omnichannel Database through Oceana Customer Management Tool (OCMT) before a customer contact forwards the account to Avaya Oceana®.
- Account value: The value that the end customer supplies during the customer's interaction with the Avaya Oceana® contact center.

Currently, Avaya Oceana® supports accounts for voice and generic channels only.

- In voice channel, two methods of orchestrating front-end IVR are Avaya Experience Portal and Avaya Aura® Call Center Elite.

 **Note:**

The sample Experience Portal IVR application collects the account value from voice callers. This sample IVR application and the Call Center Elite workflow are available on DevConnect.

The account is used to retrieve the internal customer ID value associated with the account from the Omnistore database through the CustomerManagementService and OCPDataServices snap-ins. The customer ID value is then used to track the customer interactions using Avaya Context Store Snap-in and the customer journey feature in Avaya Oceana®. The account of the current customer interaction is stored, retrieved, and updated in Avaya Context Store Snap-in through the OceanaCoreDataService, Oceana Pluggable Data Connector, and the Engagement Designer tasks. The updated information is then retrieved and updated through the sample Engagement Designer workflows that enable the customer journey to display the account of current customer interaction with the previous interactions of the customer in Avaya Oceana®.

- In generic channel support, for each generic contact entered in Avaya Oceana®, an account is specified with the contact, which is then stored in the Oceana Omnistore database. All generic contacts that contain an account are tracked and used by customer journey in the same way as voice interactions.

 **Warning:**

Avaya Oceana® does not validate any customer entered account value or CRM identifier value against data stored in the Omnichannel database. For more details on validation caveats, see *Avaya Oceana® Release Notes*.

### Capturing custom data from Avaya Oceana® voice calls

Avaya Context Store Snap-in provides a centralized solution to store contextual information about PSTN voice callers and their contacts. Avaya Context Store Snap-in can store context entries which consist of several data elements. The following are the key data elements:

- ContextID: A text field that contains a unique identification for the context. You can specify the contextID while adding the context entry in Context Store. If you do not specify a contextID while creating a context, Context Store generates a unique id.
- Data: The data field in a context entry is an abstract map with multiple key-value pairs. Keys in the data field must be unique. Multiple identical keys in the same request results in the values being overwritten with the last key.

For more information about other Avaya Context Store Snap-in data elements, see *Avaya Context Store Snap-in Reference*

Avaya Context Store Snap-in maps the front-end customer's data model into the Context Store data model. You must consider the type of data and the size of data that you want to store in Context Store. There are several methods to add or update data in Context Store.

If your solution includes Avaya Experience Portal (AAEP), Avaya Oceana<sup>®</sup> provides a Pluggable Data Connector (PDC) to integrate with AAEP. AAEP uses call flows created in Orchestration Designer (OD) to handle incoming PSTN calls and capture customer data. When you install the Avaya Oceana<sup>®</sup> PDC in OD, a Context Store Connector node is available in OD. You can use the Context Store Connector node to integrate Avaya Context Store Snap-in into your call flows. You can also configure the Context Store Connector node to perform actions such as creating, getting, updating, or deleting context information using the contextID.

The other components of an Avaya Context Store Snap-in deployment are the External Data Mart (EDM) database and Journey PU. Avaya Context Store Snap-in uses the Journey PU to persist Context Store data to the External Data Mart. Components such as Customer Journey can retrieve the data from the External Data Mart when required, and present it to Avaya Oceana<sup>®</sup> users. Context Store data expires after the predefined Lease Time parameter expires. The Lease Time parameter is configurable, and Context Store preserves a context entry until the lease time expires. Any Avaya Context Store Snap-in client can renew this lease time, or time-to-live at any time. The default value for lease time is 7200 seconds, you can configure the lease time to be any value between 1 second and 86400 seconds. Clients can also define the lease time while creating a context and specify different lease time values for different scenarios. If a context is accessed after its lease time has expired, then it is resurrected back into the data grid from the External Data Mart, using the default lease time.

The following rules apply to adding, updating, and deleting Avaya Context Store Snap-in data in an Avaya Oceana<sup>®</sup> deployment:

- Context Store stores the default standard schema detail (caller attributes and Work Assignment related data) against a unique contextID.
- You can pass custom data into Context Store using the Data element. For example, a customer's ticket number, location, or interest. Using a customized version of the default Avaya Oceana<sup>®</sup> AAEP application, you can capture callers custom data and insert it to an existing Work Request ID (in Avaya Oceana<sup>®</sup>, the Context ID and the Work Request ID are set to the same value) using the Data field of that existing Work Request. This is on the assumption that there is an existing Work Request ID and it is available to the AAEP application if deployed. The Work Request ID can be generated by Context Store in an Avaya Oceana<sup>®</sup> and AAEP deployment. If you use Elite IVR, the UCID value is used. AAEP is not required if you use Elite IVR.
- Avaya Oceana<sup>®</sup> supports data privacy. To adhere to data privacy laws, custom data is not stored in the EDM database by default. If there is a requirement to store custom data, an administrator can change the default setting.
- Avaya recommends a maximum value of 600 Bytes for the custom data field size. If you want to use a larger data field size, please contact Avaya Support.

For other Avaya Context Store Snap-in deployments where there is a requirement to add custom data, see *Avaya Context Store Snap-in Developer Guide* and *Avaya Context Store Snap-in Reference*, available on the Avaya Support website at <https://support.avaya.com>.

---

## Browser close and network connection issues

In Avaya Workspaces , if an agent closes the browser without logging out or the client session is disconnected, the Work Assignment component stops and hence no new work is routed to that agent. The client session can be disconnected due to various reasons, such as browser refresh,

browser crash, network changes, system shutdown or sleep, and Avaya Breeze® platform load balancer fail.

Avaya Workspaces does the following once the configured timeout value has expired:

- Changes the agent to Not Ready when the agent is not active on an interaction
- Changes the agent state to Not Ready Pending when the agent is active on an interaction and then changes to Not Ready when the active interaction ends.
- Sends a pop-up toast message to the supervisor. Avaya Workspaces also sends the message when the agent browser disconnects.

When changing the state to Not Ready, Avaya Workspaces also sets the Not Ready reason code. The administrator must configure this reason code in Avaya Control Manager. The agent cannot select this Not Ready Reason code when logged into Avaya Workspaces.

The administrator must also configure the timeout setting to a value from 0 to 300 seconds.

---

## Last Agent Routing

Avaya Oceana® supports the Last Agent Routing feature for Voice, Chat, Email, Social, Generic, Messaging, or SMS interactions. With this feature, the sample Engagement Designer workflow routes an interaction to the same agent who previously interacted with the same customer. If the same agent is unavailable, then the workflow routes the call interaction to the most idle agent that matches the service.

---

## Last Email Routing

Avaya Oceana® supports the Last Email Routing feature for email interactions. With this feature, the sample Engagement Designer workflow routes a customer email interaction to the agent who last handled the interaction. This feature is applicable to agents and supervisors.

---

## Service level configuration and reporting

Avaya Oceana® supports service-level configuration of thresholds for Channels and Named Services in Avaya Control Manager.

In Avaya Control Manager, you can configure thresholds for Channels and Named Services from the SLA Threshold Management page.

Thresholds for Channels are defined in UCA and can be configured in Control Manager. When you configure existing thresholds, data is synchronized between Control Manager and UCA.

Thresholds for Named Services are defined in Work Assignment Portal. You can create new thresholds or configure existing thresholds for these Named Services in Control Manager. When you create or configure thresholds, data is synchronized between Control Manager and UCA.

On the SLA Threshold Management page, you can delete the thresholds for Named Services created from this page, but not the Channels.

Avaya Analytics™ can report against service level targets. Avaya Analytics™ receives the threshold values from Avaya Oceana® and creates a wait time measure, which is reported on in Routing Service real-time reports.

## Virtualization

Avaya Oceana® is deployed on virtualized platforms utilizing VMware ESXi. This deployment in turn is deployed on actual physical hosts. Each Avaya Breeze® platform server instance on the host virtual machine must be allocated the reserved memory and vCPU configuration.

The customer and the external integrator must supply all virtualization software, licenses, and hardware to host the virtualized deployment. Avaya recommends that the Avaya Breeze® platform installation, which is part of a single cluster, must be hosted on different VMware ESXi hosts. This guarantees service availability and ensures high availability of the solution even if one of the VMware ESXi hosts is unavailable.

## VMware configuration

**!** Important:

You can deploy your Avaya Analytics™ on the same VMware cluster as Avaya Oceana® subject to the VMware following supported features table:

VMware Feature	Avaya Oceana®	Avaya Analytics™  <b>Warning:</b> <b>Do not delete nodes or VMs from your VMware.</b>
<p>A single VMware cluster can be shared between Avaya Oceana® 3.8.x and Avaya Analytics™ 4.x.</p> <ul style="list-style-type: none"> <li>The cluster contains virtual machines for both Avaya Oceana® 3.8.x and Avaya Analytics™ 4.x.</li> <li>The cluster can also contain virtual machines of other applications without contention.</li> </ul> <p><b>* Note:</b> Avaya Oceana® 3.8.x and Avaya Analytics™ 4.x. can also be supported in separate clusters.</p>	<p>Yes</p> <p>For instructions on enabling affinity rules in a DRS-enabled VMware cluster, see <i>Deploying Avaya Oceana®</i>.</p>	<p>Yes</p> <p>For more information, see <i>Deploying Avaya Analytics</i>.</p>

Table continues...



VMware Feature	Avaya Oceana®	Avaya Analytics™  <b>Warning:</b> Do not delete nodes or VMs from your VMware.
Cloning	No	No Alternate mechanisms using BOSH.
Distributed Resource Scheduler (DRS)	Yes For the documented guidelines in conjunction with affinity rules, see <i>Deploying Avaya Oceana®</i> .	Yes For the documented guidelines on HA and DRS rules for Avaya Analytics™ 4.1.x, see <i>Deploying Avaya Analytics</i> .
Storage DRS	No Avaya Oceana® does not support this feature. There are impacts to the datastores. The input or output load balancing occurring in the production can cause outages.	No Avaya Analytics™ 4.1.x does not support datastore clusters.
Distributed Power Management (DPM)	No	No
Distributed Switch (Network)	Yes <ul style="list-style-type: none"> <li>Requires VMware Enterprise Plus license.</li> <li> <b>Note:</b> Loss of vCenter indicates that you cannot manage data networks on the hosts.</li> <li>If you use standard vSwitch, you can do the management from each host.</li> </ul>	Yes <ul style="list-style-type: none"> <li>Requires VMware Enterprise Plus license.</li> <li> <b>Note:</b> Loss of vCenter indicates that you cannot manage the data networks on the hosts.</li> <li>If you use standard vSwitch, you can do the management from each host.</li> </ul>
Fault Tolerance	No	No Alternate mechanism using BOSH.

Table continues...



VMware Feature	Avaya Oceana®	Avaya Analytics™  <b>Warning:</b> <b>Do not delete nodes or VMs from your VMware.</b>
High Availability (HA)*	<p>No</p> <ul style="list-style-type: none"> <li>• Avaya Oceana® does not support impacts to the virtual machines occurring in the production.</li> <li>• For more information on configuring VMware HA in an Avaya Oceana® and Avaya Analytics™ single cluster deployment, see <i>Deploying Avaya Oceana®</i>.</li> </ul>	<p>Yes</p> <ul style="list-style-type: none"> <li>• Mandatory for Avaya Analytics™ 4.1.x High Availability feature.</li> <li>• For the documented guidelines on HA and DRS rules for Avaya Analytics™ 4.1.x, see <i>Deploying Avaya Analytics</i>.</li> </ul>
Snapshots***	<p>Partial</p> <ul style="list-style-type: none"> <li>• Yes, as part of maintenance** procedures only for upgrades or patching.</li> <li>• Remove snapshots before putting back contact center into the production mode.</li> </ul>	<p>Partial</p> <ul style="list-style-type: none"> <li>• Yes, as part of maintenance** procedures for upgrades or patching only for the following Analytics application:  Cluster Control Manager (CCM) — Remove snapshots before putting back contact center into the production mode.</li> <li>• All other Avaya Analytics™ Servers BOSH and the 3 Avaya Analytics™ VMs do not support use of snapshots.</li> </ul>
Storage Thin Provisioning	<p>Partial</p> <ul style="list-style-type: none"> <li>• Yes, for SAN storage.</li> <li>• No, for local hard disk storage.</li> </ul>	<p>Yes</p> <ul style="list-style-type: none"> <li>• Yes, for SAN storage.</li> <li>• No local storage supported.</li> </ul> <p> <b>Note:</b> Applicable only to Avaya Analytics™ on HA.</p> <ul style="list-style-type: none"> <li>• For more information on specifics of thin provisioning, see <i>Deploying Avaya Analytics</i>.</li> </ul>

Table continues...



VMware Feature	Avaya Oceana®	Avaya Analytics™  <b>Warning:</b> <b>Do not delete nodes or VMs from your VMware.</b>
vMotion	Supported in maintenance mode only. Not supported in production mode.  For more information, see <i>Deploying Avaya Oceana®</i> .	Supported in maintenance mode only. Not supported in production mode.  For more information, see <i>Deploying Avaya Analytics</i> .
Storage vMotion	No  Avaya Oceana®/Avaya Analytics™ does not support any form of vMotion including Storage vMotion, as it might impact real-time application behaviour and event processing on the associated virtual machines.	No  Avaya Oceana®/Avaya Analytics™ does not support any form of vMotion including Storage vMotion, as it might impact real-time application behaviour and event processing on the associated virtual machines.
Suspend and Resume	No	No
Cold Migration	Yes <ul style="list-style-type: none"> <li>You can do a cold migration only on a virtual machine in a powered-off state.</li> <li>Avaya Oceana® uses static IPs. Therefore, the new ESXI host(s) must have access to the original data network and datastore for the migrated virtual machines.</li> </ul>	Yes <ul style="list-style-type: none"> <li>You can do cold migration only on a virtual machine in a powered-off state.</li> <li>Avaya Analytics™ uses static IPs. Therefore Avaya Analytics™ virtual machines can only be migrated to hosts in the same VMware that has the same access to all elements in the cluster as existing hosts.</li> </ul> <p>When performing any cold migrations of Avaya Analytics™ virtual machines from host to host, see the <i>Considerations for upgrading Physical Hosts running Avaya Analytics™ virtual Machine</i> section in <i>Deploying Avaya Analytics™</i>.</p>

Table continues...

VMware Feature	Avaya Oceana®	Avaya Analytics™  <b>Warning:</b> <b>Do not delete nodes or VMs from your VMware.</b>
Reservations on vCPU and memory required to be enabled	<p>Yes</p> <ul style="list-style-type: none"> <li>• Set to <code>Yes</code>. For the production, Avaya Oceana® customers provide the VMware deployments wherever there is contention for resources.</li> <li>• Physical hosts running Avaya Oceana® virtual machines can have other virtual machines running and co-residing with the Avaya Oceana® virtual machines.</li> <li>• On Avaya Pod Fx systems, reservations are not required, because the Avaya supplied hardware is engineered not to be over provisioned.</li> </ul>	<p>No</p> <p>Avaya Analytics™ 4.1.x reservations on vCPU and memory are not mandatory, as long as the environment is not over provisioned and there is no contention for resources with other virtual machines.</p>
Hyperthreading	<p>No</p> <ul style="list-style-type: none"> <li>• Avaya Oceana® requires reservations. Therefore, Hyperthreading does not add any additional value.</li> <li>• You can enable on the VMware infrastructure for the other applications.</li> </ul>	<p>Yes</p>
<p>* Avaya Oceana® provides its own HA mechanism.</p> <p>** Maintenance mode specifies a scheduled out-of-production window where the system does not process contacts, agents are all logged out, and queues are empty. This timeframe is dedicated to tasks such as patching, upgrades, and configuration. During this timeframe, Avaya Oceana® and the applications such as Avaya Breeze® platform nodes, System Manager, Avaya Control Manager, and Omnichannel Database remain powered on and accessible on the customer network but does not process any contacts or operations. During the creation of snapshots, you must power down Avaya Oceana® and the applications such as Avaya Breeze® platform nodes, Avaya Control Manager, and Omnichannel Database.</p> <p>*** You must delete snapshots from Avaya Oceana® virtual machines before placing Avaya Oceana® back into production. Snapshots must only be taken or deleted when the virtual machine is powered down.</p>		

## Considerations for upgrading Physical Hosts running Avaya Analytics™ virtual machines

Physical hosts running Avaya Analytics™ virtual machines requires up-to-date base software including VMware itself. These software updates must be planned into a maintenance window where the contact center is not in service. In these maintenance windows, one or more physical hosts are out of service including all the virtual machines running on these hosts.

You can add or remove a host from the existing hosts in the VMware cluster.

The following are important considerations when removing or adding physical hosts to the deployment:

- Only use the Bosh Director application (Bosh) to remove the Avaya Analytics™ virtual machine nodes from the Avaya Analytics™ 4.1 cluster. This is required because the Bosh retains the system information.
- Do not remove or replace the physical VMware ESXi hosts running Avaya Analytics™ virtual machines from the VMware cluster during maintenance windows or while the Bosh is in shutdown mode.
- Under normal operating conditions, a new physical host must be added only when the Bosh is in service. This is to ensure that the Bosh becomes aware of its existence.
- In the event of a physical host failure, Bosh is aware that a node is down and does not attempt to restart the associated failing node until the host is replaced. Bosh starts a new node only if an additional host is available.
- Do not remove or add a host while the Bosh is shutdown or unavailable.
- You can add one or more physical hosts to the VMware cluster to facilitate host maintenance. It allows to migrate host virtual machines on a new host while existing host is updated.
- All the VMware permissions for the same user account, which is used to deploy the Avaya Analytics™ cluster, must be propagated to the new host before taking the new host out of maintenance mode and putting it into production. On failing to do this, Avaya Analytics™ virtual machines are unable to access resources on the new host.

---

## Web technologies supported

Avaya Oceana® supports the following web technologies for enhanced user experience:

- AngularJS v6.x and ReactJS v16.7.0
- CSS3 support

---

## Authentication between outbound connector and omnichannel resource connector

The outbound connector has the capability to authenticate all human and programmatic access prior to allowing access to resources, capabilities, or operations. The traffic on the networking products are authenticated or explicitly provisioned to be trusted at the edge of the network.

**\* Note:**

A management interface that can be accessed remotely adheres to the requirements in the remote management CEC.

## OAuth for Avaya Oceana<sup>®</sup> and Avaya Analytics<sup>™</sup> Email for Office 365

Avaya Oceana<sup>®</sup> supported basic authentication for POP3 and IMAP. Under basic authentication, a user name and password gets transmitted to authenticate users and grant them access to the e-mail service.

Microsoft has announced the end of support for basic authentication of POP3 and IMAP on O365. This affects all the customers currently using O365 exchange services.

Avaya Oceana<sup>®</sup> supports OAuth to be able to allow our customers to continue to operate their email channels.

## Supported Agent Transfer and Conference scenarios for voice calls

Avaya Oceana<sup>®</sup> agents can perform the following transfer and conference actions using Avaya Workspaces:

Action	Destination				
	Service	Avaya Oceana <sup>®</sup> user	IVR	Internal non-Avaya Oceana <sup>®</sup>	External non-Avaya Oceana <sup>®</sup>
Blind Transfer	Yes	Yes	Yes	Yes	Yes
Consult Transfer	Yes	No*	No	Yes	Yes
Conference	Yes	No*	No	Yes	Yes

\* You can do it using basic CTI transfer, but without Transfer to User reason codes and reporting.

## Supported Agent Forward, Transfer, and Conference scenarios for digital contacts

Avaya Oceana<sup>®</sup> digital agents can perform the following forward, transfer, and conference actions using Avaya Workspaces:

**Email**

Action	Destination			
Email	Service	Avaya Oceana® user	Internal non-Avaya Oceana®	External non-Avaya Oceana®
Forward	No	No	Yes	Yes
Transfer	Yes	Yes	No	No

**Chat**

Action	Destination			
Chat	Service	Avaya Oceana® user	Internal non-Avaya Oceana®	External non-Avaya Oceana®
Transfer	Yes	Yes	No	No

**SMS**

Action	Destination			
SMS	Service	Avaya Oceana® user	Internal non-Avaya Oceana®	External non-Avaya Oceana®
Transfer	Yes	Yes	No	No

**Social**

Action	Destination			
Social	Service	Avaya Oceana® user	Internal non-Avaya Oceana®	External non-Avaya Oceana®
Transfer	Yes	Yes	No	No

**Generic**

Action	Destination			
Generic	Service	Avaya Oceana® user	Internal non-Avaya Oceana®	External non-Avaya Oceana®
Transfer	Yes	Yes	No	No

**Web Voice**

Action	Destination			
Web Voice	Service	Avaya Oceana® user	Internal non-Avaya Oceana®	External non-Avaya Oceana®
Transfer	Yes	No	No	No

*Table continues...*

Action	Destination			
Web Voice	Service	Avaya Oceana® user	Internal non-Avaya Oceana®	External non-Avaya Oceana®
Consult Transfer	No	No You can do it using basic CTI transfer, but without Transfer to User reason codes and reporting.	No	No
Conference	No	No You can do it using basic CTI transfer, but without Transfer to User reason codes and reporting.	No	No

**Messaging**

Action	Destination			
Messaging	Service	Avaya Oceana® user	Internal non-Avaya Oceana®	External non-Avaya Oceana®
Transfer	Yes	Yes	No	No

---

## Avaya Workspaces features

---

### Web browser-based access

Avaya Workspaces is directly accessible through a web browser. To use the capabilities of Avaya Workspaces, agents do not need to install or configure any application on their systems. Agents can directly access the web interface to use the capabilities that the organization deems appropriate for defined roles. It enforces minimal client-side logic and minimal administrative burden.

---

### Modern and responsive design

Avaya Workspaces supports multiple screen sizes and device form factors. With this feature, agents and supervisors can resize the browser window with consequent automatic content adjustment.

---

## Single interface for all contact center applications

Avaya Workspaces provides a consolidation layer through which customers can show existing services such as CRM or Knowledge Management to agents and supervisors. The open interface of Avaya Workspaces presents services from any vendor to agents in context through the same interface.

---

## Real-time reporting through Supervisor reporting dashboard

In Avaya Oceana<sup>®</sup>, the supervisor reporting dashboard provides real-time reporting capabilities. Using Avaya Workspaces, you can view real-time reporting dashboards to monitor up-to-date statistics for your contact center and resources.

You can view changes in call activity in real time by using the supervisor reporting dashboard. Avaya Analytics<sup>™</sup> provides real-time data for your dashboards. You can administer permissions for supervisor reporting dashboard users by using Avaya Control Manager. Avaya Control Manager administrators can assign create, modify, delete, and view permissions to users.

The supervisor reporting dashboard is available for administrators, supervisors, and reporting users. Agents cannot access the supervisor reporting dashboard. Supervisor reporting users use various widgets to manage and view dashboard, and manage reporting views, calculated measures, and threshold classes.

### Dashboard

A dashboard is a collection of one or more real-time data views. A view consists of a reporting widget, and a widget is an individual report control type. The supervisor reporting dashboard supports the following widgets:

- Bar chart
- Pie chart
- Column chart
- Billboard
- Table

#### **Note:**

You cannot modify default dashboards. All users can clone these dashboards.

Users can create, modify, delete, and view dashboards depending on the role type of the user. You can create new dashboards using the supervisor reporting dashboard. Administrators can create dashboards that are public and available to all users. Supervisors can create private dashboards, visible only to the supervisor user that creates them. You can export a dashboard, which administrator users can then import for public use. All users can also make a clone of an existing default or public dashboard. Cloned dashboards are private. You can create a maximum of 6 private dashboards and 6 public dashboards. The reporting external window is dependent on the data delivered in Avaya Workspaces. For the data in a given dashboard to be displayed in the external window, you must select the corresponding dashboard in Avaya Workspaces. Once the dashboard is selected, the data in both external and internal windows is updated and displayed in sync.

## Views and measures

To create views, Avaya Workspaces uses producers provided by Avaya Analytics™. Avaya Analytics™ provides a list of measures that are available for use in each view. You can add multiple measures to Bar chart, Pie chart, Column chart, and Table views. Billboard views support a single measure only.

### Important:

A maximum of 100 measures can be added to a view.

You can create calculated measures, which you can use to make compound calculations based on standard Avaya Analytics™ measures. The values for these calculated measures are sent by Avaya Analytics™ for use in views. For example, you can create a calculated measure that calculates the percentage value of offered calls not answered by agents.

When you create a new dashboard, you can select the views that the dashboard displays. You can add views to a dashboard using a number of default layouts. A layout defines the position of each view on the dashboard. You can arrange views vertically, horizontally, or a combination of both.

You can create new views by using one of the supported widgets. For example, create a new Pie chart view using the Pie chart widget. Select the producer to be associated with the view, and then select the measures to be displayed on the view. You can also change the order of the measures and apply formatting changes. You can create an unlimited number of views.

Administrators can create views that are public and available to all users. Supervisors can create private views, visible only to the supervisor user that creates them. You can clone an existing private, or public view. If an administrator clones a view, it is public. Otherwise, cloned views are private.

When you create a view, you must specify the viewing mode for the real-time producers. The options are:

- Start of Day: View measures accumulated since the start of the current day.
- Contact Detail Records: View measures relating to individual contacts. These measures are not bounded by any interval timeframes such as Moving Window or Start of Day.

You can create views to support a single instance or multiple instances of data. If you select single instance the measures displayed on the view relate to a single data dimension only, for example an Agent or a Routing Service. If you select multiple instance the measures displayed on the view relate to a collection of data, for example a collection of Agents or Routing Services.

The default refresh rate for all dashboards is 1 second.

You can configure chart control settings for your view. Choose from the following chart control options for your view:

- Default: This is the default aggregation setting. Each measure in your view is visualized separately for each dimension. For example, if you use an agent-related producer, a separate entry appears per agent for each measure selected.
- Grouping: If you use the Grouping setting, each measure in your view is grouped, and each dimension is visualized by using color coding and the measure value for each dimension is represented in the view.
- Aggregation: If you use the Aggregation setting, each measure in your view is visualized separately and the sum of all values for each measure is displayed.

You can apply filtering on the data that is visible for each table view on the dashboard. For example, you can apply filters on any measure displayed in a particular table view. You cannot apply filtering at the dashboard level.

## Producers

A producer is a collection of measures, grouped to provide contextual real-time data to supervisor reporting dashboard users. Avaya Analytics™ provides the following producers to Avaya Workspaces for use in real-time reporting dashboards:

- Agent
- Agent Group
- Agent by Account
- Agent by Aux Code
- Routing Service
- Routing Service by Agent
- Site
- VDN
- Contact Detail

You can create dashboards using Start of Day measures from each producer, with the exception of the Contact Detail producer.

---

## User management for Supervisor reporting dashboard

You can administer permissions for supervisor reporting dashboard users through Avaya Control Manager. Avaya Control Manager administrators can assign, create, modify, delete, and view permissions to users.

The types of supervisor reporting dashboard users are:

- Avaya Analytics™ Administrator: This user has permissions to access the supervisor reporting dashboard, but does not use any other Avaya Workspaces features. For example, this user cannot handle interactions. This user sees all agents when viewing a dashboard.
- Avaya Analytics™ Supervisor: This user has permissions to access the supervisor reporting dashboard, but does not use any other Avaya Workspaces features. For example, this user cannot handle interactions. This user sees agents that are assigned to them in Avaya Control Manager Agent Groups.

You can assign Avaya Oceana® permissions to supervisor reporting dashboard users in conjunction with Avaya Analytics™ permissions. You assign Avaya Oceana® permissions to Avaya Workspaces users.

The types of Avaya Workspaces users are:

- Avaya Workspaces Administrator: This user is a standard Avaya Workspaces administrator. You can assign this user Avaya Analytics™ administrator or supervisor permissions to access the supervisor reporting dashboard.

- **Avaya Workspaces Supervisor:** This user is a standard Avaya Workspaces supervisor. You can assign this user Avaya Analytics™ supervisor permissions to access the supervisor reporting dashboard.

What each user sees when they log on to Avaya Workspaces depends on the permissions assigned to them in Avaya Control Manager. For example, an Avaya Analytics™ Supervisor with no other user permissions assigned does not see the interaction area in Avaya Workspaces, they see only the supervisor reporting dashboard tabs. You grant supervisor reporting dashboard access permission to these users using Avaya Control Manager. For more information about how to administer permissions for supervisor reporting dashboard users, see *Administering Avaya Oceana®*.

## Assigning thresholds for views and measures

You can use thresholds in views to identify the lower and upper end of the normal range for a measure. You can also add thresholds to specify levels in between the lower and upper ends. You can assign different colors for measures below the normal range, within the normal range, or above the normal range. Real-time views use colors to highlight measures when a measure breaches a configured threshold value. This visually alerts supervisor reporting dashboard users to significant reporting data, such as a high volume of waiting calls that requires immediate attention.

Administrators can create threshold classes that are public and available to all users. Supervisors can create private threshold classes, visible only to the supervisor user that creates them. You can clone an existing private or public threshold class. If an administrator clones a threshold class, it is public. Otherwise, cloned threshold classes are private. You can apply thresholds on table and billboard views only. You can add up to 5 thresholds for each measure.

## Canned real-time dashboards and views in Avaya Workspaces

The Avaya Workspaces supervisor reporting dashboard includes a number of default dashboards that all users can open. Avaya Analytics™ provides real-time data for your dashboards. The default dashboards, along with the views that they contain, are listed in the following table:

**Table 7: Real-time reports**

Dashboard	Description
Agent Performance	This dashboard contains the following views: <ul style="list-style-type: none"> <li>• Agent Status tabular display</li> <li>• Agent Behaviour tabular display</li> <li>• Agent bar chart</li> </ul>

*Table continues...*

Dashboard	Description
Contact Summary	This dashboard contains the following views: <ul style="list-style-type: none"> <li>• Contacts Waiting in Queue Billboard</li> <li>• Contacts Abandoned from Queue Billboard</li> <li>• Contacts Offered Billboard</li> <li>• Contacts Answered Billboard</li> <li>• Contacts at Agents Billboard</li> <li>• Contacts Transferred to Service Billboard</li> <li>• Contacts Transferred to Agent Billboard</li> <li>• Contacts Consults Billboard</li> <li>• Contacts Holds Billboard</li> <li>• Contacts Deferred Billboard</li> <li>• Contacts Conference Billboard</li> <li>• Contacts Completed Billboard</li> </ul>
Routing Performance Summary	This dashboard contains the following views: <ul style="list-style-type: none"> <li>• Service Distribution tabular display</li> </ul>

---

## Blended agents

Avaya Workspaces supports the blended agents feature. With this feature, agents can seamlessly handle Voice, Chat, Email, SMS, Video, Social, and Messaging interactions using the same interface. For example, if an agent has voice and email capabilities, then the agent can simultaneously handle a voice and an email interaction.

---

## Extensibility

Avaya Workspaces is extensible application that can accommodate the changes and new capabilities of your contact center.

Avaya Workspaces is extensible:

- Without having any impact on the existing functionality.
- With limited or no downtime.

## Web browsers supported

Avaya Workspaces supports the following web browsers:

- Google Chrome
- Mozilla Firefox
- Apple Safari
- Microsoft Edge Chromium

---

## Customization of transfer to service list

Avaya Workspaces provides an option to customize the Transfer to Service list through Avaya Workspaces administrator interface so that the agents get a reduced Transfer to Service list.

When agents start working on work cards, Avaya Workspaces provides a Transfer to Service list. The list contains all the available services where the agents can transfer the interactions. By default, Avaya Workspaces retrieves the list from Avaya Oceana®.

The Transfer to Service feature works only if the list of all services exists in Unified Collaboration Administrator (UCA). The widget developer must ensure that the content of the Transfer to Service list sent to Avaya Workspaces is a subset of the overall list of services in UCA. If an entry sent to Avaya Workspaces is not available in UCA and an agent tries to use that entry, Avaya Oceana® presents an error message to the agent informing that the request cannot be processed.

You can use the Transfer to Service feature when you determine that:

- The interaction came to you in error.
- You cannot help the customer and the interaction must be sent to a service that is better equipped to address the interaction.

The system displays only those transfer services contained in the data groups that are assigned to the agent in Avaya Control Manager.

Transfer to a service is a single-step transfer. After you click the service to which you want to transfer, you are dropped from the interaction. The customer hears a wait tone until an agent from the service accepts the interaction.

Avaya Workspaces supports the Transfer to Service feature for Voice, Chat, Email, SMS, Web Voice, Social Media, Messaging, Video, and Generic channels.

---

## Workflow design

Avaya Oceana® includes Avaya Engagement Designer, which is a user-friendly workflow design tool. Avaya Engagement Designer provides a visual drag and drop design approach for making it easier to bring the right resources, content, and context together across your CRM and other systems to deliver a holistic customer engagement management environment.

Flexible workflows can change with business needs, reduce cost, and increase the speed of implementing customer journey workflows.

---

## Address book support for LDAP

The Avaya Workspaces address book can search for enterprise directory contacts using LDAP. To use the address book to search for LDAP contacts, your solution must include Avaya Aura<sup>®</sup> Device Services (AADS). You can use the single sign-on (SSO) capabilities for Avaya Aura<sup>®</sup> Device Services users who were previously authenticated using the Avaya Breeze<sup>®</sup> platform AuthorizationService.

---

## Start work button behavior

Avaya Workspaces provides an administrator with options to configure the behavior of the **Start work** button. This is applicable for all agents. With this setting, administrators can allow agents to choose to start work in either the ready or not ready state. When an agent starts work in Avaya Workspaces, the agent state is set to ready by default.

---

## Single sign-on in Avaya Workspaces

Avaya Workspaces supports the usage of the credentials of an active directory to log on to Avaya Workspaces.

The Avaya Workspaces address book uses Avaya Aura<sup>®</sup> Device Services to search for enterprise directory contacts using LDAP. You can enable single sign-on (SSO) capabilities for Avaya Aura<sup>®</sup> Device Services users that previously authenticated using the Avaya Breeze<sup>®</sup> platform AuthorizationService. This allows Avaya Workspaces users to use the address book to search for enterprise directory contacts using LDAP, without needing to separately authorize with Avaya Aura<sup>®</sup> Device Services.

You can configure Avaya Breeze<sup>®</sup> platform Authorization Service attributes to enable SAML. The Avaya Breeze<sup>®</sup> platform Authorization Service also supports IWA/Kerberos authentication.

### **LDAP integration:**

When attempting to access the Avaya Workspaces URL, unauthorized users are redirected to the Avaya Breeze<sup>®</sup> platform Authorization Service. If LDAP integration is configured, Avaya Breeze<sup>®</sup> platform prompts the user for credentials. After a successful authentication, Avaya Breeze<sup>®</sup> platform grants users authorization permissions using an authorization token. If users have the correct permissions set in Avaya Control Manager, they can access Avaya Workspaces.

### **SAML integration:**

When attempting to access the Avaya Workspaces URL, unauthorized users are redirected to the Avaya Breeze<sup>®</sup> platform Authorization Service. If SAML integration is configured, the Authorization Service redirects users to your identity provider (IdP), and prompts the user for credentials. After a

successful authentication, Avaya Breeze® platform grants users authorization permissions using an authorization token. If users have the correct permissions set in Avaya Control Manager, they can access Avaya Workspaces.

#### **IWA/Kerberos integration:**

If the Avaya Breeze® platform Authorization Service is configured for IWA/Kerberos authentication, the Authorization Service automatically uses the Windows credentials of the user for authentication. You do not need to manually enter your credentials when accessing Avaya Workspaces. When attempting to access the Avaya Workspaces URL, users are redirected to the Avaya Breeze® platform Authorization Service, which uses IWA to automatically grant users authorization permissions using an authorization token. If users have the correct permissions set in Avaya Control Manager, they can access Avaya Workspaces.

When users exit Avaya Workspaces, they are redirected to the Exit page. Users can choose to immediately return to Avaya Workspaces. If Authorization Service permits, the Activate Agent screen appears and users can log on again without entering credentials.

For more information about Avaya Breeze® platform, SAML, and Kerberos authentication, see the Avaya Breeze® platform documentation available at <https://support.avaya.com>.

---

## **Endpoint support for voice calls using Avaya Workspaces**

Avaya Workspaces provides the functionality to handle PSTN voice calls using a supported Avaya Aura® desk phone or softphone as your endpoint. WebRTC agents using Avaya Workspaces can handle PSTN voice calls or WebRTC calls through Avaya Workspaces without requiring an Avaya Aura® endpoint.

---

## **Receive interactions**

Avaya Workspaces provides the **Accept** icon to accept interactions with a single click. When an agent receives an interaction card in Avaya Workspaces, the agent can accept the interaction by clicking the **Accept** icon on the interaction card and start interacting with the customer.

---

## **Hold or resume interactions**

Avaya Workspaces provides the **Hold/Resume** icon to put an active interaction on hold. When an agent working on an active interaction receives another higher priority interaction, the agent can put the active interaction on hold by clicking the **Hold/Resume** icon on the interaction card. Whenever needed, the agent can resume the active interaction by clicking the **Hold/Resume** icon on the interaction card.

This icon is available to agents and supervisors for the voice channel.

---

## Auto answering

Avaya Workspaces supports auto answering for all interactions. The agent has a visual indication that an alerting contact is auto-answered.

This feature is applicable to all channels except Web voice and Web video.

---

## Consult agents

Avaya Workspaces supports the Consult feature. With this feature, an agent working on an active interaction can call other agents to seek advise on an interaction.

This feature is applicable to agents and supervisors for the PSTN voice channel.

---

## Supported transfer operations

### Transfer interactions

Avaya Workspaces supports the Transfer feature. With this feature, an agent can transfer an active interaction to the interaction area of another agent. You can transfer interactions for both voice and digital channels.

### Transfer to service

In Avaya Workspaces, an agent can transfer an interaction to a predefined service that you configure in Avaya Control Manager.

When an agent starts working on a work card, Avaya Workspaces provides a Transfer to Service list. The list contains all the available services where the agent can transfer the interaction. By default, Avaya Workspaces retrieves the list from Avaya Oceana®.

This feature applies to agents and supervisors for all channels except the Outbound channel.

### Transfer to supervisor

In Avaya Workspaces, an agent can transfer the interaction to a supervisor. While working on an active interaction, an agent can transfer the interaction to a supervisor by clicking the **Transfer** icon and selecting the name of the supervisor from the list.

The list displays the supervisor of the team at the beginning of the team list.

This feature applies to agents and supervisors for the voice channel.

### Transfer to user

Avaya Workspaces supports transfer of any digital channel to another agent or a supervisor in a single-step transfer using the **Transfer to user** option. The agents or supervisors can pass incoming work to a different agent or supervisor. However, the agent or the supervisor must be within the contact center and qualified to address an incoming customer query.

---

## Addition of another agent to the interaction

Avaya Workspaces supports addition of another agent to the interaction and create a conference if you determine that the other agent can contribute to resolving the customer interaction. You initiate a three way conference so that the customer, consulted agent, and user are placed in conversation.

This feature is applicable to agents and supervisors for Web voice and PSTN voice channels.

---

## Recording of work codes for reporting

Avaya Workspaces supports selection from the configured work codes to report the type of work done during the interaction.

This feature is applicable to agents and supervisors for all channels except the Outbound channel.

---

## Customer Journey

With Avaya Workspaces, you can view a visual representation of a customer's interactions. Every point in Customer Journey is visualized by an interaction with a channel, such as Voice, Video, Email, SMS, Chat, Social Media, or Messaging.

This feature is applicable to agents and supervisors for all channels.

---

## Co-browse support

Avaya Workspaces for Avaya Oceana® supports browsing of the same webpages by two users simultaneously through the Avaya Co-Browsing Snap-in.

Using Avaya Co-Browsing Snap-in, a customer and an agent can browse the same webpages to collaborate on certain tasks. The agent can assist the customer to perform various actions on the Avaya Co-Browsing Snap-in enabled webpages. For example, an agent can help a customer in navigating through the webpages and filling out forms. Using the snap-in, you can also generate summary reports about agents, sessions, and customers.

Avaya Co-Browsing Snap-in leverages the Document Object Model (DOM), which is an application programming interface (API) for valid HTML documents.

Avaya Co-Browsing Snap-in consists of the following components:

- Server: CoBrowse snap-in svar, which is installed on Avaya Breeze® platform. It provides REST Web Service API that is used by the co-browsing client SDK called Sharing Services.

For more information about APIs, see the Programming guide for Sharing Services under Avaya Breeze® Client SDK at [DevConnect](#).

- Client SDK or Sharing Services: CoBrowse JavaScript SDK to integrate with the website for which you want to enable co-browsing.

 **Note:**

Only one concurrent co-browse session can take place between an agent and a customer.

---

## Screenpops

Avaya Workspaces provides screenpops to agents. With screenpops, agents can access external webpages to complete their tasks. For example, access to external websites with information such as current currency exchange rates.

When agents click the Screenpop icon, they can view the Screenpop widget. The Screenpop widget displays external web content that can help an agent to complete the customer interaction. If the external web content is sourced from non-secure sources, the content can be blocked from being displayed in Avaya Workspaces.

Screenpops can be configured to be available for any interaction type.

This feature is applicable to agents and supervisors for all channels.

---

## Timed after contact work

Avaya Workspaces provides the Timed After Contact Work (ACW) feature. Using this feature, you can record the time spent on activities that are done after the interaction ends.

This feature is applicable to agents and supervisors for all channels.

 **Note:**

There is no ACW for ad-hoc emails.

Avaya Oceana<sup>®</sup> version 3.8.1 enhances the existing ACW feature by introducing a per-service and per-channel configuration and only alters the duration of ACW once triggered.

 **Important:**

- Initial preference is given to the service and then the channel. If an exact matching set of attributes are present in an Avaya Control Manager service, ACW for that service is selected. In all other scenarios, the channel-specific ACW is used.
- If ACW for the matched service is zero, it is considered as no ACW. Therefore, no attempt is made to use a channel-specific timer.
- The range of the service-specific and channel-specific timer is from 0 to 9999.
- Avaya Proactive Outreach Manager feature uses the voice channel ACW.

**\* Note:**

**Timed ACW** setting on Avaya Aura® Communication Manager must not be used. This is to ensure that:

- ACW is not enabled both on Communication Manager and Control Manager.
- Consistent and predictable ACW behavior across all the channels.

---

## Customer history search

Avaya Oceana® agents can view customer history details using the Avaya Workspaces for Avaya Oceana® Customer History widget. Depending on the search parameters, the widget displays previous interactions with a customer with the date and time, status, priority, and channel of the customer request and provides access to customer history search.

Agents can add multiple search parameters simultaneously, change the combination of the parameters, and get the desired results while doing a customer history search. The agents can search customer history using the following parameters: Date, Customer Email, Subject, To address.

**\* Note:**

Currently, the search parameters are connected by AND. Therefore, different combinations of the same parameters display the same result. For example, the results for **To Address** and **Date** are the same as **Date** and **To Address**.

Agents can view the customer information widgets for all Avaya Oceana® interactions. With the exception of voice history, all other interaction history details of the customer is displayed in this widget.

---

## Address book

In Avaya Workspaces, you can search for contacts in your address book. You can retrieve contacts in your team, from an enterprise directory using LDAP, or from Salesforce.

This feature is applicable to agents and supervisors for all channels.

---

## Disposition codes

In Avaya Workspaces, agents can set disposition codes for every interaction while the interaction is active or immediately after the interaction ends.

Disposition codes are tags to indicate the state of the contact.

For example, agents can set:

- ComplaintResolved, DissatisfiedCustomer, and FollowUp disposition codes after closing the interaction.
- PostBrochure, CustomerCallback, and LikeOnSocial disposition codes during the interaction to capture the actions that the agents need to do.

**\* Note:**

Disposition code set during ACW is not stored in Customer Journey.

This feature is applicable to agents and supervisors for all channels.

---

## Defer email

### Agent

In Avaya Workspaces, an agent can defer an email for a specified number of hours for additional research and consultation. Deferring emails only applies to emails that are in assigned states.

### Supervisor

In Avaya Workspaces, a supervisor can defer emails if the agent is unavailable.

A supervisor can:

- Take ownership of the deferred email, complete the email, and send it to the customer.
- View the list of emails deferred by the agents in the team.
- Transfer the deferred email to another service.

---

## Agent monitoring

In Avaya Workspaces, supervisors can:

- Monitor agent states, work items, and performance.

This feature is applicable to supervisors for all channels.

- Mentor agents or initiate an agent observe and barge in.

This feature is applicable to supervisors for chat, messaging, and SMS channels.

---

## Observe

In Avaya Workspaces, supervisors can observe ongoing interactions between agents and customers to assess whether intervention is required. The observe session ends if the agent being observed transfers the interaction to another agent.

This feature is applicable to supervisors for chat, messaging, and SMS channels.

---

## Barge

In Avaya Workspaces, supervisors can barge in to the interactions that they are observing. After a supervisor barges in to an interaction, the supervisor gets complete control of the interaction.

This feature is applicable to supervisors for chat, messaging, and SMS channels.

---

## Agent state change

In Avaya Workspaces, supervisors can change the state of the agents in their teams. For example, a supervisor can change the state of an agent to Not Ready or Logged Out to prevent calls being routed to that agent.

This feature is applicable to supervisors for all channels.

---

## Transfer and conference of PSTN and Web voice calls

In Avaya Workspaces agents can transfer PSTN or Web voice calls to another agents or supervisors. Agents can also add another agents or supervisors to ongoing PSTN and Web voice calls.

Avaya Workspaces allows a user to place a customer interaction on hold while they consult with another consulted agent. After consulting with that agent, the user can choose to drop the consult call and resume the main conversation with the customer. The user can also choose to complete the consult as a conference. This allows the user to end the consult call initiating a three way conference so that the customer, consulted agent, and user are placed in conversation.

This feature is applicable to agents and supervisors for the PSTN and Web voice channels.

## Supported Agent Transfer and Conference scenarios for voice calls

Avaya Oceana<sup>®</sup> agents can perform the following transfer and conference actions using Avaya Workspaces:

Action	Destination				
	Service	Avaya Oceana <sup>®</sup> user	IVR	Internal non-Avaya Oceana <sup>®</sup>	External non-Avaya Oceana <sup>®</sup>
Blind Transfer	Yes	Yes	Yes	Yes	Yes
Consult Transfer	Yes	No*	No	Yes	Yes
Conference	Yes	No*	No	Yes	Yes

\* You can do it using basic CTI transfer, but without Transfer to User reason codes and reporting.

---

## Outbound email approval process

Avaya Oceana® can be configured to require the outgoing emails to be approved prior to being sent out to a customer. Emails can require approval either by an individual or by a group of designated approvers.

This review capability in a contact center is commonly referred to as “Approval of outgoing email”, “Approval of agent email replies”, “Supervisor Email Approval”, or “Email approval”. This is required for quality assurance, to ensure that the agents are responding to the customer queries in a proper manner.

**\* Note:**

The emails approved and sent to customers reflect in the customer history and customer journey. Emails rejected by the approvers do not reflect in the customer history or customer journey. The rejected emails are available only to the administrator, through the audit trail.

Avaya Analytics™ supports the ability to generate reports on the approval or rejection of outbound emails, for both real-time and historical operations.

### Workflow

1. Customers reach out for support and service by sending emails to specific email addresses published by the business.
2. The agent accepts the new email and sends the reply.

**\* Note:**

The agent does not receive any indication that the email is marked for approval.

3. Based on the business requirements, policies, and compliance, a specified percentage of email responses by agents go through a verification process for quality assurance.
4. A percentage of email responses get assigned to an individual approver selected from a group of approvers, for approving the outbound emails.
5. The approver either approves or rejects the email. The rejected emails are routed back to the agent with notes and/or instructions to be incorporated, before the response is sent back to the approver for further review. Approved emails are sent to the customer.

---

## Integration of Avaya Workspaces for Avaya Oceana® and Avaya Workplace Client

### Avaya Workplace Client overview

Avaya Workplace Client is a SIP-based softphone application. Using this application, users can access the Avaya Aura® Unified Communications voice features. Users can also access the conferencing capabilities, video capabilities, collaboration and presence, directory features, and screen sharing.

Depending on the customer infrastructure, you can deploy Avaya Workplace Client on-premise in the enterprise, or outside the enterprise. The Avaya Workplace Client can be deployed outside the

enterprise as an internet-based remote worker application, connecting through Avaya Aura® Session Border Controller to the back-end Avaya Aura® applications.

The primary user type supports voice and or video calls, Instant Messenger (IM), and presence. Avaya Workplace Client also provides Over the Top (OTT) functionality, such as conferencing and directory integration, depending on the license. The OTT functionality is independent of the Avaya Oceana® contact center applications.

Avaya Workplace Client customers can deploy the full range of the supported features and integrations to Avaya Oceana®. These features are not used by the Avaya Oceana® main application or integrated into Avaya Oceana® outside the Avaya Workplace Client.

For more information, see the following documents:

- *Avaya Workplace Client Overview and Specification for Android, iOS, Mac, and Windows*
- *Using Avaya Workplace Client for Android, iOS, Mac, and Windows*
- *Planning for and Administering Avaya Workplace Client for Android, iOS, Mac, and Windows*

### Avaya Workspaces for Avaya Oceana® and Avaya Workplace Client

The deployment of the Avaya Workplace Client is independent of the Avaya Oceana® solution. However, there are pre-requisites for the Avaya Aura® infrastructure configuration to implement the Avaya Workplace Client in a secure telecommunications environment.

The following table lists the minimum versions of the Avaya Aura® infrastructure required to support Avaya Workplace Client as a SIP endpoint for Avaya Oceana® and Avaya Analytics™ users:

**Table 8: Avaya Aura® infrastructure**

Components	Minimum Tested Versions*
Avaya Aura® System Manager	8.1.3
Avaya Aura® Session Manager	8.1.3
Avaya Aura® Communication Manager	8.1.3.1.0-FP3SP1
Avaya Aura® Media Server	8.0.2
Avaya Aura® Application Enablement Services	8.1.3
Avaya Workplace Client	3.14, 3.15, and 3.16
*Earlier versions of these products are not tested.	

---

## Social messaging platforms

You can integrate the following social messaging platforms with Avaya Oceana® through the Avaya Digital Connection platform:

- WhatsApp
- Facebook
- Twitter

For more information on integration of social messaging platforms, see *Using Avaya Workspaces for Avaya Oceana®*.

---

# Avaya Analytics™ features

---

## Historical reporting

The Historical reporting dashboard displays the historical data of the contact center resources, such as agents and routing points. These reports provide a quick view of contact center performance for the scheduled duration. You can use these as a reference to evaluate the historical performance of the relevant contact center resource. Empirical data helps you understand progress and performance over time and take informed decisions for future usage. Avaya Analytics™ supports inbound and outbound reporting through historical dashboards.

Historical reports use interval-based measures, daily roll-up data, or monthly roll up data to display a snapshot of the contact center. The data retention period of these reports are configurable.

Supervisors can select the routing services within a routing service group for reporting and track the channels' historical performance. Supervisors can only view routing services and routing service measures associated with the routing service group to which they are assigned.

You can configure Routing Service Groups for Historical Reporting in Avaya Analytics™. You can also assign supervisors to the System Routing Service Group, which allows them to bypass individual Routing Service Group filters and access all of the routing service information in all groups.

 **Note:**

- The historical summary and trend reports that return interval-based measures do not include data from the current 15-minute interval until data aggregation is run for the interval. By default, report caching settings are set to 15 minutes. Hence, the data for the current interval not displaying in the report for up to 30 minutes is normal.
- The historical summary and trend reports that return daily roll-up based data do not include data from the current day. Hence, the data is calculated only the next day.
- The historical summary and trend reports that return monthly roll-up based data do not include data from the current month. Hence, the data is calculated only the next month.

Avaya Analytics™ uses Avaya Analytics™ Web, an intuitive web-based reporting application, as the historical reporting presentation engine. Avaya Analytics™ Web runs on Avaya Common Services.

---

## Call Profile reports

Supervisors can use the Call Profile historical reporting feature in Avaya Analytics™ to compare the call performance of routing services for a selected duration. Supervisors can view these reports for the routing services in the Routing Service Groups to which they are assigned. Using the information obtained from these reports, they can plan process improvements or make business decisions for their routing services.

The Following Call Profile reports are available in Avaya Analytics™:

- **Call Profile Abandoned:** Calls that were abandoned after specific durations at different intervals
- **Call Profile Answered:** Calls that were answered after specific durations at different intervals
- **Call Profile Active Time Duration:** Calls that were active for specific durations at different intervals
- **Call Profile Waiting in Queue:** Calls that were queued for specific durations before they were answered

---

## Real-time reporting

In an Avaya Oceana®, the Supervisor Reporting Dashboard provides real-time reporting capabilities. Using Avaya Workspaces, supervisors can run real-time reporting dashboards to monitor up-to-date statistics for your contact center and resources. You can view changes in call activity in real time using the Supervisor Reporting Dashboard. Avaya Analytics™ provides the real-time data for your dashboards.

For more detailed information about the Avaya Workspaces Supervisor Reporting Dashboard, see [Real-time reporting through Supervisor reporting dashboard](#) on page 89.

---

## Assigning thresholds for views and measures

You can use thresholds in views to identify the lower and upper end of the normal range for a measure. You can also add thresholds to specify levels in between the lower and upper ends. You can assign different colors for measures below the normal range, within the normal range, or above the normal range. Real-time views use colors to highlight measures when a measure breaches a configured threshold value. This visually alerts supervisor reporting dashboard users to significant reporting data, such as a high volume of waiting calls that requires immediate attention.

Administrators can create threshold classes that are public and available to all users. Supervisors can create private threshold classes, visible only to the supervisor user that creates them. You can clone an existing private or public threshold class. If an administrator clones a threshold class, it is public. Otherwise, cloned threshold classes are private. You can apply thresholds on table and billboard views only. You can add up to 5 thresholds for each measure.

---

## Canned historical dashboards and reports in Avaya Analytics™

Avaya Analytics™ provides the following canned reports.

Agent and Routing Service Performance reports are based on 15-minute historical intervals - Daily, Weekly, Monthly and Yearly.

**Table 9: Historical reports based on 15 minutes fixed intervals**

Reports	Description
Agent Behaviour	A dashboard that displays individual occurrences of agent behaviors that are associated with engagement handling activities.
Agent Compare	A dashboard for comparing agents on different measures.
Agent Configuration	A dashboard to view agent information and agent properties.
Agent Login/Logout	A report that displays login and logout events for each agent, and the session duration for each agent log on.
Agent Not Ready By Reason Code	A report that displays the reason code associated with the agent not ready state.
Agent Performance Bottom 5	A daily dashboard that summarizes the agent performance information for the bottom 5 agents, that is, those who completed the lowest number of customer engagements.
Agent Performance Top 5	A daily dashboard that summarizes the agent performance information for the top 5 agents, that is, those who successfully completed the highest number of customer engagements.
Contact Center Performance Summary	A report that displays the performance summary of a contact center site.
Engagement	A dashboard that displays data related to customer engagements across various parameters. For example, Engagement Summary Report, Engagement Detail Report, Engagement Contact Report, Contact Detail Report, and Segment Detail Report.
Messaging Engagement Summary	A dashboard that displays data related to customer engagements originated on the Messaging channel across various parameters.
Routing Service Summary	A dashboard to track the overall performance of a routing service for the current reporting period.
Supervisor Activity	A dashboard that displays a summary of the supervisor's activity for the current reporting interval.
Supervised Agent Activity	A dashboard that displays details of supervised agents and their behavior aspects in the current reporting interval.
Supervised Agent Compare	A dashboard that displays a comparison of supervised agents for the current reporting interval.
Time Series	A dashboard that displays the engagement of agents with an individual routing service for the current interval.
VDN Summary	A report that displays the performance of a routing point.

**Table 10: Historical drill down reports based on 15 minutes fixed intervals**

Reports	Description
Account by Agent Summary	A dashboard that provides a summary of agents who handled the contacts for the accounts.  You can drill down to the Agent Interaction report to view the type of contact that the agent had.
Agent by Routing Service	A dashboard that displays how agents use routing services for the current interval.  You can drill down to the Agent Interaction report to view the type of contact that the agent had.
Agent Performance Summary	A dashboard to monitor overall performance and productivity of agents by channel for the current reporting period.  You can drill down to the Agent Interaction report to view the type of contact that the agent had.
Agent Interaction Detail	A drill down dashboard that filters on a single agent to display the agent interactions. This dashboard is available as a drill down report from Agent Performance, Account by Agent, and Agent By Routing Service reports.

Agent and Routing Service Performance reports are based on daily roll-up data. The supported interval options are Daily, Weekly, Monthly and Yearly.

**Table 11: Historical reports based on daily roll-up data**

Reports	Description
Agent Behaviour	A dashboard that displays individual occurrences of agent behaviors that are associated with engagement handling activities.
Agent Compare	A dashboard for comparing agents on different measures.
Agent Configuration	A dashboard to view agent information and agent properties.
Agent Login/Logout	A report that displays login and logout events for each agent, and the session duration for each agent log on.
Agent Not Ready By Reason Code	A report that displays the reason code associated with the agent not ready state.
Agent Performance Bottom 5	A daily dashboard that summarizes the agent performance information for the bottom 5 agents, that is, those who completed the lowest number of customer engagements.
Agent Performance Top 5	A daily dashboard that summarizes the agent performance information for the top 5 agents, that is, those who successfully completed the highest number of customer engagements.
Contact Center Performance Summary	A report that displays the performance summary of a contact center site.

*Table continues...*

Reports	Description
Engagement	A dashboard that displays data related to customer engagements across various parameters. For example, Engagement Summary Report, Engagement Detail Report, Engagement Contact Report, Contact Detail Report, and Segment Detail Report.
Routing Service Summary	A dashboard to track the overall performance of a routing service for the current reporting period.
Supervisor Activity	A dashboard that displays a summary of the supervisor's activity for the current reporting interval.
Supervised Agent Activity	A dashboard that displays details of supervised agents and their behavior aspects in the current reporting interval.
Supervised Agent Compare	A dashboard that displays a comparison of supervised agents for the current reporting interval.
Time Series	A dashboard that displays the engagement of agents with an individual routing service for the current interval.
VDN Summary	A report that displays the performance of a routing point.

Agent and Routing Service Performance reports are based on monthly roll-up data. The supported interval options are Monthly and Yearly.

**Table 12: Historical reports based on monthly roll-up data**

Reports	Description
Agent Behaviour	A dashboard that displays individual occurrences of agent behaviors that are associated with engagement handling activities.
Agent Compare	A dashboard for comparing agents on different measures.
Agent Configuration	A dashboard to view agent information and agent properties.
Agent Login/Logout	A report that displays login and logout events for each agent, and the session duration for each agent log on.
Agent Not Ready By Reason Code	A report that displays the reason code associated with the agent not ready state.
Agent Performance Bottom 5	A daily dashboard that summarizes the agent performance information for the bottom 5 agents, that is, those who completed the lowest number of customer engagements.
Agent Performance Top 5	A daily dashboard that summarizes the agent performance information for the top 5 agents, that is, those who successfully completed the highest number of customer engagements.
Contact Center Performance Summary	A report that displays the performance summary of a contact center site.
Engagement	A dashboard that displays data related to customer engagements across various parameters. For example, Engagement Summary Report, Engagement Detail Report, Engagement Contact Report, Contact Detail Report, and Segment Detail Report.

*Table continues...*

Reports	Description
Routing Service Summary	A dashboard to track the overall performance of a routing service for the current reporting period.
Supervisor Activity	A dashboard that displays a summary of the supervisor’s activity for the current reporting interval.
Supervised Agent Activity	A dashboard that displays details of supervised agents and their behavior aspects in the current reporting interval.
Supervised Agent Compare	A dashboard that displays a comparison of supervised agents for the current reporting interval.
Time Series	A dashboard that displays the engagement of agents with an individual routing service for the current interval.
VDN Summary	A report that displays the performance of a routing point.

## Canned real-time dashboards and views in Avaya Workspaces

The Avaya Workspaces supervisor reporting dashboard includes a number of default dashboards that all users can open. Avaya Analytics™ provides real-time data for your dashboards. The default dashboards, along with the views that they contain, are listed in the following table:

**Table 13: Real-time reports**

Dashboard	Description
Agent Performance	<p>This dashboard contains the following views:</p> <ul style="list-style-type: none"> <li>• Agent Status tabular display</li> <li>• Agent Behaviour tabular display</li> <li>• Agent bar chart</li> </ul>

*Table continues...*

Dashboard	Description
Contact Summary	<p>This dashboard contains the following views:</p> <ul style="list-style-type: none"> <li>• Contacts Waiting in Queue Billboard</li> <li>• Contacts Abandoned from Queue Billboard</li> <li>• Contacts Offered Billboard</li> <li>• Contacts Answered Billboard</li> <li>• Contacts at Agents Billboard</li> <li>• Contacts Transferred to Service Billboard</li> <li>• Contacts Transferred to Agent Billboard</li> <li>• Contacts Consults Billboard</li> <li>• Contacts Holds Billboard</li> <li>• Contacts Deferred Billboard</li> <li>• Contacts Conference Billboard</li> <li>• Contacts Completed Billboard</li> </ul>
Routing Performance Summary	<p>This dashboard contains the following views:</p> <ul style="list-style-type: none"> <li>• Service Distribution tabular display</li> </ul>

---

## Full database backup on a remote server

You can run an immediate backup or schedule to run an automatic full backup of the Avaya Analytics™ historical reporting database to a remote server. The remote server can be Windows or Linux server and it is located outside of the cluster. The full database backup is taken using the pgdump tool.

Avaya recommends to use remote backups as these are stored outside the Avaya Analytics™ Cluster to help avoid loss of backups.

Avaya Analytics™ notifies the administrator during install or upgrade if the backup rules or schedules are not configured.

---

## Upscaling Avaya Analytics™ overview

To accommodate the changes in the existing configuration, you can perform upscaling of the cluster in Avaya Analytics™. The upscaling process involves increasing the VMware node resources for the Avaya Common Services cluster by allocating additional CPU, memory, and disk storage.

Avaya Analytics™ upscaling supports the following actions:

- Increasing the active agent count for Avaya Analytics™ without a full re-deployment of the Avaya Analytics™ application.

- Adding capacity to deploy new features such as Async messaging without impacting the existing deployed applications.
- Upscaling is supported in Avaya Analytics™ 4.1.1.0 release. If you are using an older release, then you must upgrade to Avaya Analytics™ 4.1.1.0 and only then you can perform an upscale.

**\* Note:**

Upgrading and upscaling are not supported at the same time.

The upscaling of the cluster is managed using the deployment spreadsheet, which pre-calculates the additional CPU, Memory, and disk storage requirements based on the updated configuration. For more information on upscaling the cluster, contact Avaya support at <https://support.avaya.com>.

**\* Note:**

Upscaling from non-HA to HA deployments and downscaling are not supported as a part of the Avaya Analytics™ 4.1.1.0 release.

---

## Avaya Analytics™ DR monitoring tool

Avaya Analytics™ offers a DR monitoring tool which allows you to manually check the status of replication between primary and replica pods on DC1 and between DC1 and DC2. It helps in troubleshooting system functionality and ensures that a system is in a good state before configuring Geo-Replication on DC2.

The Avaya Analytics™ DR monitoring tool helps in identifying and troubleshooting the following issues:

- Database split-brain: If there are two pods in a cluster running in master or active mode, then this is a problem that needs attention.
- Failover occurrence: If the pod called **crunchy-primary-service-orca-dbmgr-0** is listed as a slave, a failover occurs. During Geo system configuration, the pod **crunchy-primary-service-orca-dbmgr-0** should be active before configuring the DC2 standby system.
- Replication interruption: If the status field is not listed as `streaming` in any location, then replication does not occur
- Replication delay: Provide details on how long a replication is running. This information is used to determine if there is some lag in replication due to slow network or hardware unable to process all the replicated data in good time.
- Network targets: The output can be used to verify if the hosts/IP addresses that the components are communicating with are the expected values.

---

## Enhanced CSV file for WFO integration

You can configure Avaya Analytics™ to generate CSV files for Agent By Account and Routing Service historical reports.

The Interval CSV Producer puts data into the CSV file at an interval of 15 minutes. The Daily CSV Producer generates a new CSV file with a unique name once every 24 hours.

Avaya Analytics supports the delivery of the CSV file in the following manner:

- Every 15 mins, information rolls up into a running daily total. The running total resets at midnight every day.
- Every 24 hours, information rolls up into the daily totals. The CSV file is generated just after midnight each day, reporting on the values from the previous day.

You can share historical reporting data with Avaya Aura® Workforce Optimization and Non-Avaya Aura® Workforce Optimization solutions.

# Chapter 6: Capacity specifications

The following table shows the capacity specifications for Avaya Oceana® when deployed on-premise:

Parameter	On-Premise only			
	4500-agents	2000-agents	1000-agents	100-agents
Maximum number of active Avaya Workspaces agents including supervisors and agents (Supervisors logged in as active agents)	4500 * <b>Note:</b> Of this maximum figure, 1000 agents can be digital agents.	2000	1000	100
Maximum supported configured channels per Agent	4 Voice + 3 digital	4 Voice + 3 digital	4 Voice + 3 digital	4 Voice + 3 digital
Maximum number of active Avaya Workspaces users including supervisors and agents (Supervisors not logged in as active agents)	4950	2200	1100	110
Maximum number of configured users (agents and supervisors)	14850	6600	3300	330
Maximum number of configured agents	13500	6000	3000	300
Maximum number of configured supervisors	1350	600	300	30
Maximum number of active supervisors using Avaya Workspaces	450	200	100	10
Maximum number of active voice agents	4500	2000	1000	100
Maximum number of configured Social agents	300	300	300	100

*Table continues...*

Parameter	On-Premise only			
	4500-agents	2000-agents	1000-agents	100-agents
Maximum number of active Social agents	300	300	300	30
Maximum number of configured Outbound agents	500	300	300	10
Maximum number of active Outbound agents	500	300	300	10
Maximum number of concurrent Avaya Workspaces instances per agent	1	1	1	1
Maximum number of concurrent Avaya Workspaces instances per supervisor	1	1	1	1
Maximum supported Voice Busy Hour Call Completion (BHCC) - Self Service	45000	30000	30000	3000
Maximum supported Voice Busy Hour Call Completion (BHCC) - Assisted Service	45000	20000	10000	1000
Maximum supported Busy Hour Call Completion (BHCC) - Outbound	10000	6000	6000	200
Maximum supported Chat/Email/SMS/Social interactions per hour	12000	12000	6000	600
Maximum supported Chat interactions per hour Assumes no other multimedia channel is active.	12000	12000	6000	600
Maximum supported Messaging interactions per hour Assumes no other multimedia channel is active.	12000	12000	6000	600
Maximum supported Email per hour Assumes no other multimedia channel is active.	12000	12000	6000	600
Maximum supported SMS per hour Assumes no other multimedia channel is active.	12000	12000	6000	600

Table continues...

Capacity specifications

Parameter	On-Premise only			
	4500-agents	2000-agents	1000-agents	100-agents
Maximum supported Social per hour Assumes no other multimedia channel is active.	1800	1800	600	600
Maximum supported Generic Channel per hour Assumes no other multimedia channel is active.	12000	12000	6000	600
Maximum number of concurrent Web Voice sessions***	1000	1000	1000	100
Maximum number of concurrent Web Video sessions***	500	500	500	50
Maximum number of concurrent Chat sessions per agent	3	3	3	3
Maximum number of concurrent Emails per agent	3	3	3	3
Maximum number of concurrent SMS sessions per agent	3	3	3	3
Maximum number of concurrent Social sessions per agent	3	3	3	3
Maximum number of concurrent Generic Channel sessions per agent	3	3	3	3
Maximum number of Ad-hoc Email per agent	1	1	1	1
Maximum deferred Email interactions	10000	6000	3000	500
Maximum number of deferred Emails per agent	10	10	10	10
Maximum number of Observe Chat per agent	3	3	3	3
Number of concurrent Co-Browse sessions per node	200	200	200	20
Maximum number of concurrent Chat sessions	2200	2200	1100	110
Maximum number of concurrent Chat sessions per customer	10	10	10	10
Total number of services supported	5000	5000	5000	1000

Table continues...

Parameter	On-Premise only			
	4500-agents	2000-agents	1000-agents	100-agents
Number of services supported per agent	2000	2000	2000	1000
Maximum number of attributes per Service	10 Channel + 9 attributes	10 Channel + 9 attributes	10 Channel + 9 attributes	10 Channel + 9 attributes
Maximum number of attributes per agent*	500	500	500	500
Maximum queued contacts across all channels	25000	25000	10000	1000
Maximum queued Voice contacts	8000	8000	4000	400
Maximum queued Chat contacts	2000	2000	1000	100
Maximum queued Messaging contacts	4500	4500	2250	225
Maximum queued Email contacts**	25000	25000	10000	1000
Maximum queued Social contacts	2200	2200	1100	110
Maximum queued SMS contacts	2200	2200	1100	110
Maximum queued Generic Channel contacts	10000	10000	3000	200
Maximum number of Avaya WebRTC Connect agents	1000	1000	1000	100
Number of concurrent Chatbot sessions with two Chatbot servers	900	900	900	150
Maximum number of Communication Managers	<ul style="list-style-type: none"> <li>• 1 CM/CCElite Simplex</li> <li>OR</li> <li>• 1 CM/CCElite Duplex</li> <li>OR</li> <li>• 1 CM/CCElite Simplex or Duplex with associated ESS</li> </ul>	<ul style="list-style-type: none"> <li>• 1 CM/CCElite Simplex</li> <li>OR</li> <li>• 1 CM/CCElite Duplex</li> <li>OR</li> <li>• 1 CM/CCElite Simplex or Duplex with associated ESS</li> </ul>	<ul style="list-style-type: none"> <li>• 1 CM/CCElite Simplex</li> <li>OR</li> <li>• 1 CM/CCElite Duplex</li> <li>OR</li> <li>• 1 CM/CCElite Simplex or Duplex with associated ESS</li> </ul>	<ul style="list-style-type: none"> <li>• 1 CM/CCElite Simplex</li> <li>OR</li> <li>• 1 CM/CCElite Duplex</li> <li>OR</li> <li>• 1 CM/CCElite Simplex or Duplex with associated ESS</li> </ul>
Maximum number of Transfer to Service operations	2000			

Table continues...

Capacity specifications

Parameter	On-Premise only			
	4500-agents	2000-agents	1000-agents	100-agents
Maximum number of Engagement Designer Workflow Instances (WFIs) per cluster	25000	25000	10000	1000
Maximum number of Engagement Designer Workflow Definitions (WFDs) per cluster	200			
Maximum number of contacts allowed on the OCP database	7 million			
Maximum number of digital contacts per customer	700			
Maximum number of public real-time views that an administrator can create and view	60			
Maximum number of private real-time views that a supervisor can create and view	60			
Maximum number of public dashboards that an administrator can create	10			
Maximum number of private dashboards a supervisor can create	10			
<p>* The total number of attributes is 50 times the maximum number of configured users. For example, in a 2000-agent deployment, the maximum number of configured users is 6600. Therefore, you can configure a total of 6600*50 attributes.</p> <p>**Queued emails are the emails that arrive at the contact center but are not yet closed. This includes active emails that agents are currently processing, emails in deferred state, and emails that are awaiting agent's availability.</p> <p>*** To calculate the maximum supported sessions for a mixed Web Voice and Web Video environment, 1 Web Video session is equivalent to 2 Web Voice sessions.</p> <p>For example, a large profile system can support one of the following:</p> <ul style="list-style-type: none"> <li>• maximum 1000 Web Voice</li> <li>• maximum 500 Web Video</li> <li>• maximum 500 Web Voice and 250 Web Video</li> </ul> <p>Ensure that your solution is engineered correctly to support the required WebRTC session counts.</p>				

---

## Omnichannel database customer contact ratio

The customer to contact ratio in Avaya Oceana® must not exceed a ratio of 1:700 (or 1 customer record per 700 contacts). To avoid exceeding the ratio, whenever possible, each contact must generate a new customer record. Email manager creates a new customer record automatically when a unique from address is found. The ratio allows sufficient scope for multiple threads of conversation with a single customer (where agent and customer exchange a number of email messages).

Contacts in Avaya Oceana® are generated from a variety of sources:

- standard email messages
- Web chat
- SMS
- Social
- Generic
- Messaging

When a contact is generated in Avaya Oceana®, a customer record is created to capture details of the sender and capture the details of the service request. You must ensure that each new sender is unique where possible to ensure correct threading of contacts and efficient system operation.

It is critical that you do not define a single sender (for example, an email mailbox) for all contacts. This leads to an unsustainable ratio of customers to contacts in the database.

If business practice includes using a mailbox (for example, a do-not-reply mailbox), to send multiple contacts into Avaya Oceana® you must use the Oceana Data Management Tool archive facility to ensure the contact-customer ratio is kept within the supported limits. Reducing the customer to contact ratio ensures logical threading of customer messages on Avaya Workspaces and also ensures efficient system operation.

This consideration applies to all types of contacts. Web chat requests must also create unique customer records rather than converging all requests on a single customer record.

 **Note:**

Oceana Data Viewer displays a list of customers with the highest number of contacts. The system administrators are advised to check this regularly.

# Chapter 7: Avaya Oceana<sup>®</sup> Specifications

## Hardware and software specifications

Avaya Oceana<sup>®</sup> is a suite of software applications comprising of a set of Avaya Breeze<sup>®</sup> platform Snap-Ins and additional installation software. Avaya Oceana<sup>®</sup> is deployed on virtualized platforms utilizing VMware ESXi. This deployment in turn is deployed on actual physical hosts. Each Avaya Breeze<sup>®</sup> platform server instance on the host virtual machine must be allocated the reserved memory and vCPU configuration.

### Supported virtualized environments

The customer and the external integrator must supply all virtualization software and hardware to host the virtualized deployment. Avaya recommends that the Avaya Breeze<sup>®</sup> platform installation, which is part of a single cluster, must be hosted on different VMware ESXi hosts. This guarantees service availability and ensures high availability of the solution even if one of the VMware ESXi hosts is unavailable.

All solution applications that are part of the Avaya Oceana<sup>®</sup> suite require the following virtualized environments:

VMware ESXi	Avaya Oceana <sup>®</sup>	Avaya Control Manager	Avaya Analytics <sup>™</sup>
VMware ESXi 6.5	Yes	Yes	Yes
VMware ESXi 6.7	Yes	Yes	Yes
VMware ESXi 7.0	Yes	Yes	Yes
Citrix/Xenapp 7.6	Yes	Yes	Yes

### Supported operating systems

All operating systems that Avaya Oceana<sup>®</sup> requires must be provided by the end customer where it is not explicitly provided by Avaya.

Operating system	Avaya Oceana <sup>®</sup>
Red Hat Enterprise Linux 7.9	Avaya Breeze <sup>®</sup> platform
Red Hat Enterprise Linux 7.7	Avaya Analytics <sup>™</sup> (Common Services)
Microsoft Windows 10 (x32 and x64)	Avaya Workspaces
Apple Mac OS 10.11+	Avaya Workspaces
Microsoft Windows Server 2012, 2016, and 2019 (Standard and Enterprise) with SQL Server 2012, 2014, and 2016 (Standard and Enterprise).	Avaya Control Manager

*Table continues...*

Operating system	Avaya Oceana®
Microsoft Windows Server 2016	OCP database External Data Mart (EDM) database

**\* Note:**

- Red Hat Enterprise Linux for Avaya Breeze® platform is provided by Avaya.
- Red Hat Enterprise Linux for Common Services is provided by Avaya.

### Supported browsers

Component	Microsoft Internet Explorer	Microsoft Edge	Microsoft Edge Chromium	Google Chrome (Windows and Apple MAC)	Mozilla Firefox Standard	Mozilla Firefox Enterprise (Quantum)	Apple Safari
Avaya Workspaces for Avaya Oceana®  • Supervisor and agent role Avaya Workspaces admin role  • Customer Journey  • Co-Browsing Snap-in agent role	Not supported	Not supported	84-89	78-89	76-87.0	68.12, 78.9	12, 13, 14
Co-Browsing Snap-in customer	11	44	88, 89	88, 89	85, 86	68.12, 78.8	13, 14
Avaya Control Manager	11	44	87	88	85	Not supported	13
Avaya Workspaces for Avaya Oceana® — Avaya WebRTC Connect Voice and Video agent	Not supported	Not supported	83-84	77-85	Not supported	Not supported	Not supported

*Table continues...*

Component	Microsoft Internet Explorer	Microsoft Edge	Microsoft Edge Chromium	Google Chrome (Windows and Apple MAC)	Mozilla Firefox Standard	Mozilla Firefox Enterprise (Quantum)	Apple Safari
Customer Avaya WebRTC Connect application	Not supported	Not supported	83-84	77-87	77-79	Not supported	Not supported
Customer Web Chat Portal*	Deprecated - continue to use with no support	40, 41	83	76-83	70	68.2	10, 11
Avaya Analytics™ Release 4.x Real Time Reporting (using supervisor Avaya Workspaces for Avaya Oceana®)	Not supported	Not supported	84-89	78-89	76-87.0	68.12, 78.9	Not supported
Avaya Analytics™ Release 4.x Historical Reporting	11	44	84-89	78-89	76-87.0	68.12, 78.9	12, 13, 14
Avaya Analytics™ Release 3.7.0.2 Real Time Reporting (using supervisor Avaya Workspaces for Avaya Oceana®)	Not supported	Not supported	Not supported	76-83	Not supported	Not supported	Not supported

Table continues...

Component	Microsoft Internet Explorer	Microsoft Edge	Microsoft Edge Chromium	Google Chrome (Windows and Apple MAC)	Mozilla Firefox Standard	Mozilla Firefox Enterprise (Quantum)	Apple Safari
Avaya Analytics™ Release 3.7.0.2 Historical Reporting	11	40	Not Supported	60+	52+	Not supported	9-10
Avaya Oceana® Multimedia Data Viewer & Avaya Oceana® Dashboard & Monitor	Not supported	44	87 with Click Once Extension	88	85	Not supported	Not supported
Avaya Oceana® Administration Tool and OCMT	11	44	87 with Click Once Extension	88 with Click Once Extension	85 with Click Once Extension	Not supported	Not supported
*Sample application testing							

## Supported endpoints

In addition to Avaya Workspaces for Windows, Avaya Oceana® supports the following endpoints:

Avaya endpoint/softphone	Supported versions
9600 Series IP Deskphone 96x1 (SIP)	9608, 9611, 9621, and 9641
9600 Series IP Deskphone 96x1 (H.323)	9650, 9608, and 9611
16xx series IP deskphone	1608 and 1611
46xx series IP deskphone	4620 and 4621
J100 Series	J169 and J179
Avaya one-X® Agent (H.323)	2.5.8 and later
Avaya Agent for Desktop	1.7.x, 2.0

## Supported mobile and desktop operating systems

Avaya WebRTC Connect supports the following mobile and desktop operating systems:

Platforms	Supported versions
iOS	13.4.1
Android	10.0

*Table continues...*

Platforms	Supported versions
Windows	Windows 10 Pro and Windows 10 Pro for Workstations 64-bit OS
Mac OS	11.2.3

### Supported WebRTC Agent Client Software Versions

Platforms	Supported versions
Google Chrome	89

## Avaya Oceana® hardware requirements

The following table provides information about the memory, disk, and vCPU requirements for each component of Avaya Oceana®:

Component	Platform	Requirement	Avaya Oceana®					
			4500 Agents	2000 Agents	1000 Agents	500 Agents	250 Agents	100 Agents
Avaya Oceana® Cluster 1	Avaya Breeze® platform	Number of nodes	3	3	3	3	3	3
		Memory/node	96 GB	96 GB	64 GB	48 GB	48 GB	32 GB
		Minimum disk size/node	500 GB	500 GB	500 GB	500 GB	500 GB	500 GB
		vCPUs/node	16	12	12	8	8	8
		Input Output Processing / sec (IOPs)	120	100	100	50	50	50
Avaya Oceana® Cluster 2	Avaya Breeze® platform	Number of nodes	2	2	2	2	2	0
		Memory/node	32 GB	32 GB	24 GB	24 GB	16 GB**	0
		Minimum disk size/node	350 GB	350 GB	350 GB	350 GB	350 GB	0
		vCPUs/node	8	8	4	4	4	0

Table continues...

Component	Platform	Requirement	Avaya Oceana®					
			4500 Agents	2000 Agents	1000 Agents	500 Agents	250 Agents	100 Agents
		IOPs	50	50	50	25	25	0
Avaya Oceana® Cluster 3	Avaya Breeze® platform	Number of nodes	2	2	2	2	2	2
		Memory/node	32 GB	32 GB	16 GB	16 GB	16 GB	12 GB
		Minimum disk size/node	400 GB	400 GB	400 GB	400 GB	400 GB	400 GB
		vCPUs/node	8	8	4	4	4	4
		IOPs	50	50	50	25	50	50
Avaya Oceana® Cluster 4 (Optional)	Avaya Breeze® platform	Number of nodes	3	3	2	2	2	2
		Memory/node	16 GB	16 GB	16 GB	16 GB	16 GB	8 GB
		Minimum disk size/node	400 GB	400 GB	400 GB	400 GB	400 GB	100 GB
		vCPUs/node	4	4	4	4	4	4
		IOPs	50	50	50	25	25	25
Avaya Oceana® Cluster 5 (Optional)	Avaya Breeze® platform	Number of nodes	2	2	2	2	2	2
		Memory/node	12 GB	12 GB	12 GB	12 GB	12 GB	8 GB
		Minimum disk size/node	300 GB	300 GB	300 GB	300 GB	300 GB	300 GB
		vCPUs/node	4	4	4	4	4	4
		IOPs	50	50	50	50	50	50
Omnichannel Datastore	Windows	Number of nodes	2	2	2	2	2	2
		Memory/node	16 GB	16 GB	16 GB	16 GB	16 GB	12 GB

Table continues...

Component	Platform	Requirement	Avaya Oceana®					
			4500 Agents	2000 Agents	1000 Agents	500 Agents	250 Agents	100 Agents
		Minimum disk size/node	4 Disks (100 GB, 60 GB, 1 TB, and 60 GB)	4 Disks (100 GB, 60 GB, 1 TB, and 60 GB)	4 Disks (100 GB, 60 GB, 1 TB, and 60 GB)	4 Disks (100 GB, 60 GB, 100 GB, and 60 GB)	4 Disks (100 GB, 60 GB, 100 GB, and 60 GB)	4 Disks (100 GB, 60 GB, 100 GB, and 60 GB)
		vCPUs/node	8	8	4	4	4	4
		IOPs	100	100	100	50	50	50
Avaya Control Manager	Windows	Number of nodes	2	2	2	2	2	2
		Memory/node	12 GB	12 GB	12 GB	12 GB	12 GB	12 GB
		Minimum disk size/node	300 GB	300 GB	300 GB	300 GB	300 GB	300 GB
		vCPUs/node	8	8	8	8	8	8
		IOPs	50	50	50	25	25	25
Avaya Control Manager Database	Windows	Number of nodes	2	2	2	2	2	2
		Memory/node	12 GB	12 GB	12 GB	12 GB	12 GB	12 GB
		Minimum disk size/node	300 GB	300 GB	300 GB	300 GB	300 GB	300 GB
		vCPUs/node	8	8	8	8	8	8
		IOPs	50	50	50	25		25
Avaya Context Store External Data Mart and Customer Journey Database	Windows	Number of nodes	1	1	1	1	1	1
		Memory/node	24 GB	16 GB	16 GB	16 GB	16 GB	12 GB
		Minimum disk size/node	3200 GB	2105 GB	2105 GB	2105 GB	2105 GB	215 GB

Table continues...

Component	Platform	Requirement	Avaya Oceana®					
			4500 Agents	2000 Agents	1000 Agents	500 Agents	250 Agents	100 Agents
		vCPUs/node	12	8	8	8	8	4
		IOPs	100	100	100	50		50
Avaya Control Manager Database co-resident with Avaya Context Store External Data Mart (EDM) and Customer Journey Database	Windows	Number of nodes	2	2	2	2	2	2
		Memory/node	24 GB	24 GB	24 GB	24 GB	24 GB	24 GB
		Minimum disk size/node	3500 GB	2405 GB	2405 GB	2405 GB	2405 GB	515 GB
		vCPUs/node	12	12	12	12	12	12
		IOPs	750	750	750	750	750	750
Avaya Aura® Web Gateway (Optional)	Red Hat Enterprise Linux	Number of nodes	2	2	2	2	2	2
		Memory/node	8 GB	8 GB	8 GB	8 GB	6 GB	6 GB
		Minimum disk size/node	132 GB	132 GB	132 GB	132 GB	132 GB	132 GB
		vCPUs/node	8	8	8	8	4	4
		IOPs	100	100	100	100	100	100
Avaya Aura® Device Services (Optional)	Red Hat Enterprise Linux	Number of nodes	2	2	2	2	2	2
		Memory/node	9 GB	9 GB	9 GB	9 GB	9 GB	9 GB
		Minimum disk size/node	250 GB	250 GB	250 GB	250 GB	250 GB	250 GB
		vCPUs/node	6	6	6	6	6	6

Table continues...

Component	Platform	Requirement	Avaya Oceana®					
			4500 Agents	2000 Agents	1000 Agents	500 Agents	250 Agents	100 Agents
		IOPs	100	100	100	100	100	100
Avaya Aura® Media Server (Avaya Aura® Web Gateway) (Optional)	Red Hat Enterprise Linux	Number of nodes	3*	3*	3*	2	2	2
		Memory/node	16 GB	16 GB	16 GB	16 GB	8 GB	8 GB
		Minimum disk size/node	50 GB	50 GB	50 GB	50 GB	50 GB	50 GB
		vCPUs/node	16	16	16	16	8	8
		IOPs	100	100	100	100	100	100
Avaya Aura® Media Server (Avaya Breeze® platform) (Optional)	Red Hat Enterprise Linux	Number of nodes	2	2	2	2	2	2
		Memory/node	8 GB	8 GB	8 GB	8 GB	8 GB	8 GB
		Minimum disk size/node	50 GB	50 GB	50 GB	50 GB	50 GB	50 GB
		vCPUs/node	8	8	8	8	8	8
		IOPs	100	100	100	100	100	100
Avaya Aura® Session Border Controller (Optional)	Red Hat Enterprise Linux	Number of nodes	2	2	2	2	2	2
		Memory/node	16 GB	16 GB	16 GB	16 GB	16 GB	16 GB
		Minimum disk size/node	100 GB	100 GB	100 GB	100 GB	100 GB	100 GB
		vCPUs/node	6	6	6	6	6	6
<p>**For 250 Avaya WebRTC Connect agents, Avaya Oceana® Cluster 2 requires at least 24 GB RAM to support the Avaya Mobile Video Snap-in and Avaya BotConnector Snap-in Avaya WebRTC Connect services.</p> <p>* For 1000 Avaya WebRTC Connect agents, you must have 3 Avaya Aura® Media Server nodes.</p>								

**\* Note:**

- For Avaya Oceana® deployments that support up to 100 agents, install the ZangSmsConnector SVAR on Avaya Oceana® Cluster 3.
- Each Avaya Breeze® platform node of a cluster must reside on a different physical server.
- For Red Hat Enterprise Linux (RHEL), Avaya Oceana® only supports the version that Avaya ships with the solution.
- For new deployments, Avaya Oceana® only supports the External Data Mart database running Microsoft SQL Server on a supported version of Windows Operating System.

For supported version combinations, see the following:

- SQL Server 2019: <https://docs.microsoft.com/en-us/sql/sql-server/install/hardware-and-software-requirements-for-installing-sql-server-ver15?view=sql-server-ver15>.
- SQL Server 2016 and 2017: <https://docs.microsoft.com/en-us/sql/sql-server/install/hardware-and-software-requirements-for-installing-sql-server?view=sql-server-ver15>.
- For Avaya WebRTC Connect:
  - Avaya Aura® Web Gateway OVA Profile = medium
  - Avaya Aura® Device Services OVA Profile = 1
  - Avaya Aura® Media Server (Avaya Aura® Web Gateway) OVA Profile = 5
  - Avaya Aura® Media Server (Avaya Breeze® platform) OVA Profile = 3

For High Availability (HA) deployments, you must have two instances of each of these WebRTC Connect components.

- Drive F of Omnichannel Datastore requires engineering based on the email and chat/SMS profiles of the customer.
- The ZangSmsConnector snap-in is mutually exclusive with all other SMS connectors.
- Avaya recommends two dedicated standalone Application Enablement Services (AES) servers for all Avaya Oceana® deployments to ensure AES High Availability in the solution. Currently, Avaya Oceana® does not support AES GRHA.
- For co-resident deployment of Avaya Control Manager and External Data Mart (EDM) databases, the minimum disk size/node includes the amount of disk space required to store one year of EDM Data and does not include the disk space required for SQL transaction logs or database backups. Therefore, you must create an appropriate maintenance plan to prevent the transaction log from growing rapidly. For more information about maintenance plans, see <https://docs.microsoft.com/en-us/sql/relational-databases/maintenance-plans/maintenanceplans?view=sql-server-2016> and select the appropriate version of SQL Server. Also, if you migrate EDM data from a source EDM to the co-resident Microsoft SQL server, ensure that you add sufficient disk space to accommodate the data.

---

## Avaya Workspaces for Avaya Oceana® specifications

To use Avaya Workspaces, your client machine must meet the following minimum requirements:

### Hardware requirements

- 3.20 GHz or higher Intel Core processor
- 8 GB of RAM
- 300 GB available hard disk space
- Intel HD Integrated Graphics
- Super Video Graphics Array (VGA) monitor (15 inches or larger)
- Minimum screen resolution of 1024 x 768
- Speaker and Microphone or Headset for WebRTC voice
- Webcam for WebRTC video

### Operating systems requirements

- Microsoft Windows 10 (x64)
- Microsoft Windows 10 (x32) is supported with a maximum of 4 GB RAM.
- Apple Mac OS: Minimum version: 10.11. Recommended: 11.2.3.

Avaya Workspaces computer Group Policy must allow Avaya Workspaces browser access to the microphone and webcam:

- For a voice call, ensure that you have a microphone connected and the browser has access to the microphone.
- For a video call, ensure that you have a webcam and a headset connected, and the browser has access to the webcam and the headset microphone.

Customers using VDI or RDC technologies for WebRTC clients must consider and ensure remote audio and video connectivity. Customers data infrastructure, network bandwidth, firewall, and security policies must support remote audio and video connectivity.

### Latency

Avaya Workspaces performance gets degraded or becomes unresponsive on network connections with a latency of more than 300 milliseconds RTT.

---

## Avaya Analytics™ hardware requirements for High Availability deployment

### High Availability (HA) deployment

The following table provides information about the memory, storage, and vCPU requirements for each component of Avaya Analytics™ HA deployment without messaging:

You must install Avaya Analytics™ software on each master node. You must deploy each master node on separate physical servers. Cluster Control Manager (CCM) and BOSH can reside on any

physical server instance. You require a total of five virtual machines for an Avaya Analytics™ solution deployment, which includes HA.

 **Warning:**

Do not delete nodes or VMs from your VMware.

Deployment size	Component	Number of physical servers	VMs	vCP U	RAM (GB)	IOPS	vCenter data store storage (GB)
100 agent	<b>Totals</b>	<b>3</b>	<b>5</b>	<b>35</b>	<b>99</b>	<b>300</b>	<b>2580</b>
	CCM - server 1, 2, or 3		1	1	1.5	-	
	BOSH - server 1, 2, or 3		1	1	1.5	-	
	Master node 1 - server 1		1	11	32	-	
	Master node 2 - server 2		1	11	32	-	
	Master node 3 - server 3		1	11	32	-	
500 agent	<b>Totals</b>	<b>3</b>	<b>5</b>	<b>41</b>	<b>111</b>	<b>600</b>	<b>3580</b>
	CCM - server 1, 2, or 3		1	1	1.5	-	
	BOSH - server 1, 2, or 3		1	1	1.5	-	
	Master node 1 - server 1		1	13	36	-	
	Master node 2 - server 2		1	13	36	-	
	Master node 3 - server 3		1	13	36	-	
1000 agent	<b>Totals</b>	<b>3</b>	<b>5</b>	<b>44</b>	<b>153</b>	<b>600</b>	<b>4080</b>
	CCM - server 1, 2, or 3		1	1	1.5	-	
	BOSH - server 1, 2, or 3		1	1	1.5	-	
	Master node 1 - server 1		1	14	50	-	
	Master node 2 - server 2		1	14	50	-	
	Master node 3 - server 3		1	14	50	-	
2000 agent	<b>Totals</b>	<b>3</b>	<b>5</b>	<b>56</b>	<b>195</b>	<b>900</b>	<b>5080</b>
	CCM - server 1, 2, or 3		1	1	1.5	-	
	BOSH - server 1, 2, or 3		1	1	1.5	-	
	Master node 1 - server 1		1	18	64	-	
	Master node 2 - server 2		1	18	64	-	
	Master node 3 - server 3		1	18	64	-	
4500 agent	<b>Totals</b>	<b>3</b>	<b>5</b>	<b>68</b>	<b>288</b>	<b>1200</b>	<b>6580</b>
	CCM - server 1, 2, or 3		1	1	1.5	-	
	BOSH - server 1, 2, or 3		1	1	1.5	-	
	Master node 1 - server 1		1	22	95	-	
	Master node 2 - server 2		1	22	95	-	
	Master node 3 - server 3		1	22	95	-	

**! Important:**

- You must create a data store specifically for Avaya Analytics™ usage. You can create additional data stores in vCenter for use by third-party applications. However you must ensure that the IOPS for the Avaya Analytics™ components are not affected.
- You can deploy your Avaya Analytics™ on the same VMware cluster as Avaya Oceana®. See VMware supported features as mentioned in this document.
- You can install a single Avaya Analytics™ deployment on a VMware cluster.
- Avaya Analytics™ deployment requires VMware vSphere Enterprise Plus. It supports VMware ESXi 6.5, 6.7, and 7.0.
- You must enable VMware High Availability at the VMware cluster level.
- You must enable VMware DRS to ensure that the virtual machines are deployed on different physical hosts.

**\* Note:**

Disabling VMware DRS at the cluster level removes all the existing resource pools. Then these resource pools need to be manually added into the system again. VMware displays a warning to the administrator about the impacts of turning off DRS and resource pools with the option to save a *snapshot* if required.

- Avaya Analytics™ can be deployed using thin provisioning of the disk space. For the Avaya Analytics™ application, thin provisioning of the disk storage within VMware is supported for all agent configurations. For more information on specifics of thin provisioning, see [Thin provisioning of disk storage in VMware](#) on page 134.
- Avaya Analytics™ supports LDAP version 3.
- Solid State Drives (SSD) are supported in addition to SATA, 15000 RPM.
- Only external storage is supported for HA configurations.

The external shared storage is a datastore that must be available for use during the installation of Avaya Analytics™. The automated deployment of Avaya Analytics™ for setting up volumes for the database uses external storage. The external storage is required to persist the historical data, logging, and kafka storage, located in the vCenter datastore. The external storage configured must be separate to the CCM, Bosh, and Kubernetes VM's disks.

**Analytics and Messaging deployment**

The following table provides information about the memory, storage, and vCPU requirements for each component of Avaya Analytics™ and Messaging deployment:

Deployment size	Component	VMs	vCPU	RAM (GB)	IOPS	vCenter data store storage (GB)
100 agent	<b>Totals</b>	<b>5</b>	<b>41</b>	<b>105</b>	<b>400</b>	<b>2830</b>
	CCM - server 1, 2, or 3	1	1	1.5	-	-
	BOSH - server 1, 2, or 3	1	1	1.5	-	-

*Table continues...*

Deployment size	Component	VMs	vCPU	RAM (GB)	IOPS	vCenter data store storage (GB)
	Master node 1 - server 1	1	13	34	-	-
	Master node 2 - server 2	1	13	34	-	-
	Master node 3 - server 3	1	13	34	-	-
500 agent	<b>Totals</b>	<b>5</b>	<b>47</b>	<b>123</b>	<b>700</b>	<b>3940</b>
	CCM - server 1, 2, or 3	1	1	1.5	-	-
	BOSH - server 1, 2, or 3	1	1	1.5	-	-
	Master node 1 - server 1	1	15	38	-	-
	Master node 2 - server 2	1	15	38	-	-
	Master node 3 - server 3	1	15	38	-	-
1000 agent	<b>Totals</b>	<b>5</b>	<b>53</b>	<b>165</b>	<b>700</b>	<b>4490</b>
	CCM - server 1, 2, or 3	1	1	1.5	-	-
	BOSH - server 1, 2, or 3	1	1	1.5	-	-
	Master node 1 - server 1	1	16	52	-	-
	Master node 2 - server 2	1	16	52	-	-
	Master node 3 - server 3	1	16	52	-	-
2000 agent	<b>Totals</b>	<b>5</b>	<b>65</b>	<b>228</b>	<b>1000</b>	<b>5590</b>
	CCM - server 1, 2, or 3	1	1	1.5	-	-
	BOSH - server 1, 2, or 3	1	1	1.5	-	-
	Master node 1 - server 1	1	20	66	-	-
	Master node 2 - server 2	1	20	66	-	-
	Master node 3 - server 3	1	20	66	-	-
4500 agent	<b>Totals</b>	<b>5</b>	<b>74</b>	<b>297</b>	<b>1300</b>	<b>7090</b>
	CCM - server 1, 2, or 3	1	1	1.5	-	-
	BOSH - server 1, 2, or 3	1	1	1.5	-	-
	Master node 1 - server 1	1	24	95	-	-
	Master node 2 - server 2	1	24	95	-	-
	Master node 3 - server 3	1	24	95	-	-

**\* Note:**

The Messaging deployment is applicable for customers who deploy Avaya Analytics™ and Messaging on the same platform. It does not apply to the non-HA/Lab deployment of Avaya Analytics™.

For hardware requirement details of Avaya Analytics™ on non-High Availability (HA), see the relevant section in this document.

## Thin provisioning of disk storage in VMware

Avaya Analytics™ supports thin provisioning of disk storage in VMware for all agent configurations. Though this document specifies the required disk storage space for each agent configuration, you do not have to provision the entire disk space on day 1. You can add space as and when needed. No maintenance window is required.

### **Warning:**

You must actively manage your VMware disk space and add more disk space before the application runs out of space.

Insufficient disk space provided to the system when operating with thin provisioning can result in disk write errors in the logs and a loss of data. Avaya bears no responsibility for errors and loss of data.

To ensure efficient thin provisioning, do the following:

- Provision additional disk space whenever the remaining disk space is less than 0.25 TB, assuming that you can provision additional storage within an hour or less. You are accountable for the time required to provision additional disk storage before the system reaches its current limit.
- Provision a minimum of 1TB initially for all agent configurations.

Adding additional disk space is a standard VMware operation.

## Avaya Analytics™ hardware requirements for non-High Availability deployment

### Non-HA deployment

The following table provides information about the memory, storage, and vCPU requirements for each component of Avaya Analytics™ non-HA deployment:

Deployment size	Component	Platform	VMs	vCPU	RAM (GB)	HDD (GB)	IOPS
100 agent	All nodes	ESXi host	5	30	78	1980	300
500 agent	All nodes	ESXi host	5	36	87	2580	600
1000 agent	All nodes	ESXi host	5	39	114	2880	600

### **Note:**

See the Avaya Analytics™ High Availability hardware requirements table for the Cluster Control Manager and BOSH VM sizes.

- The Avaya Analytics™ non-HA deployment option reduces the number of physical servers required from 3 to 1 and also eliminates the need for vSphere Enterprise Plus license, as

DRS is no longer required. With this option, you can reduce the footprint because you deploy only one instance of each application pod.

- Async Messaging is not supported in Avaya Analytics™ non-HA deployment.

### VMware licenses and configuration

You must deploy Avaya Analytics™ non-HA in a vCenter data center. The supported VMware versions for non-HA deployment are:

- 6.5
- 6.7
- 7.0

The licenses required for non-HA deployments are:

- vCenter Server Standard
- vSphere Standard Edition

---

## Upgrade and migration paths

### Upgrade

To upgrade all core components of Avaya Oceana®, see *Upgrading Avaya Oceana®*. To upgrade the other Avaya products that are involved in Avaya Oceana®, see the respective upgrade document of each product.

- Migration from Avaya Analytics™ Release 3.7.0.2 patch 2 to Avaya Analytics™ Release 4.1.1.0 is supported.
- Upgrade from following Releases of Avaya Analytics™ to Release 4.1.1.0 is supported:
  - 4.0.0.1 P7
  - 4.0.0.1 P8
  - 4.1.0.0
  - 4.1.0.1
  - 4.1.0.1 P1
  - 4.1.0.1 P2

### Moving from CC Elite to Oceana

Customers who already have Avaya Aura® Communication Manager and Avaya Aura® Call Center Elite can move a portion or all of the resources to Avaya Oceana®.

### Extensibility

Apart from the Avaya Breeze® platform-based snap-ins, the solution provides a number of Oceana-related snap-ins. For example, Avaya Work Assignment, Avaya BotConnector Snap-in, and Avaya Co-Browsing Snap-in and components such as Avaya Context Store and Avaya Engagement Designer. These snap-ins and components provide their own SDKs for integrating

into the customers' environment. For more information, see <http://www.avaya.com/BreezeDeveloper> and <http://www.avaya.com/DevConnect>.

# Chapter 8: Security

---

## Security considerations

Before implementing the Avaya Oceana® application, ensure that the customer security staff reviews and approves the deployment plan. Customers must engage the expertise of their security staff early in the implementation process. The security staff must decide how to incorporate the Avaya Oceana® system into the routine maintenance for virus protection, patches, and service packs.

### Payment card industry compliance

Avaya Oceana® adheres to the following security standards to meet Payment Card Industry (PCI) compliance:

- Advanced Encryption Standard (AES) 256-bit encryption to protect data when recorded, in transit, and archived on storage. Files related to voice and screen captures are stored in an encrypted form so that only users with proper access to the application can playback calls and view screens.
- The ability to mute a portion of the call recording using a CRM integration API (HTTP). For example, muting segments with credit card information.
- The ability to capture Audit trail information in logs and databases. For example who did what, and when. The information captured in the database can generate Audit trail reports on user activity such as who played recorded calls, how many times, data deletes, and data updates.
- The ability to modify storage folder structure to include client alias. This helps in setting different archival cycles and also provides folder level security across multiple clients.
- Tight integration and synchronization with Active Directory for user settings and single sign-on authentication.

### Password policy

Each Avaya Oceana® customer must create a password policy for their users. Administrators define a set of rules to maintain system security. Policies include rules for:

- Password syntax: The length and syntax.
- Password history: The number of unique passwords required before reusing an old password.
- Password expiration and lockout: The validity, warning, and grace period for expiration and lockout rules.

### **Role-based access control**

You can use roles in Avaya Oceana® to improve security and administration. Define administrative roles for your business using a role-based access control application.

To implement access control, Administrators can group a set of privileges into a role. Roles are assigned to users. Some of the commonly used roles are Agent, Supervisor, Manager, Quality Manager, and Administrator.

### **Data privacy**

The Oceana Data Management utility manages act on privacy requests from customers. For example, if a customer exercises the right to access information or their right to be forgotten, the Oceana Data Management utility provides a method to act on these requests.

---

## **SAL Policy Manager**

Avaya Oceana® uses Avaya SAL Policy Manager for increased security and ease of managing authentication policies. Customers can use the SAL Policy Manager to set various remote access policies for managed devices. The SAL Policy Manager comes with SSH Proxy, which isolates the remote user to the connected device and prevents host hopping during an SSH session.

---

## **EASG-based authentication in Avaya Oceana® and Avaya Analytics™**

### **For Avaya Oceana®**

Avaya Oceana® provides support for Enhanced Access Security Gateway (EASG) based authentication. Using a challenge-response mechanism, EASG allows service engineers and remote users to log in to Avaya Oceana® Web administrative interfaces, such as SMGR, OceanaMonitor, and DataViewer, without using credentials such as username and password.

### **For Avaya Analytics™**

Avaya Analytics™ also supports EASG-based authentication. Service engineers and remote users can log in to Avaya Analytics™ Web administrative interfaces, such as Historical Reporting, without using credentials such as username and password.

---

## **Transport layer security**

Transport Layer Security (TLS) is a cryptographic protocol used to increase security over computer networks. Avaya Oceana® supports TLS 1.0 and TLS 1.2. When you deploy the Avaya

Oceana<sup>®</sup>, by default, TLS 1.0 is configured. As per your need, you can use TLS 1.0 or TLS 1.2 in the solution.

You can change the TLS versions in the following ways:

- Globally through System Manager
- Through the Cluster Editor page

Setting TLS is a security requirement for internal communication and when you communicate with databases and LDAP.

---

## Secure communication using SSL

Avaya Oceana<sup>®</sup> provides secure communication among all snap-ins running in a secure cluster. Communication between snap-ins is only through the web.

---

## Data privacy support

---

### SocialConnector

The SocialConnector snap-in masks customer-sensitive information to ensure compliance with privacy laws such as:

- Privacy by Default
- Security of Processing

In SocialConnector, the masked fields are available in the following locations:

- Service logs at `/var/log/Avaya/services/SocialConnector.logs`
- Service Monitor messages at Avaya Oceana<sup>®</sup> Monitor logs in System Manager

SocialConnector masks the values of the following fields:

- to
- name
- account
- text
- role
- markup

- channel
- message

**\* Note:**

All the fields display the first two and last two characters of the respective values, while the remaining characters are masked with the letter x. If the length of any of the value is less than 5, the entire value gets masked.

---

## ZangSmsConnector

The ZangSmsConnector snap-in masks Personal Identifiable information (PII) to ensure compliance with privacy laws such as:

- Privacy by Default
- Security of Processing

In ZangSmsConnector, the masked fields are available in the following locations:

- Service logs
- Tracelogs
- Service Monitor

The values of the fields that are masked are:

- To or to
- From or from
- Body or body
- content
- identifier
- apiPassword

**\* Note:**

All the fields display the first two and last two characters of the respective values, while the remaining characters are masked with the letter x. If the length of any of the value is less than 5, the entire value gets masked.

---

## Co-Browsing Snap-in

Co-Browsing Snap-in supports data protection and data privacy to comply with data privacy laws.

In Co-Browsing Snap-in, data administrators can access, modify, delete, export, or restrict access to personal data and audit information to comply with privacy laws such as:

- Fulfillment of Data Subject Rights
- Personal Data Minimization – Retention

Co-Browsing Snap-in also supports data encryption.

Co-Browsing Snap-in provides a mechanism for consent management from customers to save personal data and audit information, which complies with the following data privacy law:

- Consent Management for Processing and Storage of Personal Data

---

## Guidelines for the use of antivirus software

Some security policies require the installation of antivirus software on the Omnichannel Windows Server. Avaya Oceana® supports the following antivirus products:

- McAfee
- Cylance Protect

You can deploy antivirus products from other vendors subject to the following guidelines:

- Infected file quarantine policy on the server and client: antivirus software can be configured to clean up the detected virus automatically and files must be quarantined if infected files cannot be cleaned. Contact Avaya to verify whether the quarantine file is part of our product files or dependent system file. If a virus is detected, remove the server from the network immediately during virus eradication to prevent further virus propagation.
- Do not connect a contact center application platform directly to the Internet to download virus definitions or updated files. Furthermore, Avaya recommends that you do not use a contact center application client PC to connect to the Internet. Instead, download virus definitions and updated files to another location on the customer network and manually load them from this interim location onto the contact center application platform.
- Perform the previous steps to download Oceana application service packs (SP). This method limits access to the Internet, and thus reduces the risk of downloading infected files.
- Scan all SP files, DVD-ROMs, USB drives before you upload or install to the server. This practice minimizes any exposure to infected files from outside sources.
- Capacity considerations: running virus scan software can place an additional load on a contact center application platform. The implementation personnel must run the performance monitor tool on the server to gauge CPU usage. If the antivirus software scan causes the platform average CPU usage to exceed the recommended percentage for longer than 20 minutes, the antivirus software must not be loaded onto the contact center application platform.
- Product Support do not provide support on the configuration of antivirus software, but offer guidance where possible. Direct questions or problems on antivirus software to the appropriate vendor.

- If performance or functionality issues are raised to Avaya support personnel as part of fault diagnosis, you must remove third-party utility software or antivirus software if instructed to do so.

---

## Avaya Oceana® Omnichannel Microsoft Windows Server 2016 antivirus software

Exclude the following files and folders from scans (both real-time and scheduled). Exclude all files of type LOG, or exclude all files with a specific extension `*.log`. Avaya recommends this setting when your antivirus application supports it.

- `F:\Avaya\Contact Center\Database\` (including sub-directories)  
`<additional database drive>:\Avaya\Contact Center\Databases\`  
(including sub-directories)
- `C:\Avaya\Logs\` (including sub-directories)
- Avaya log archive folder and file, any `.cbk` backup file.
- Exclude all files named `cache.dat` in any directory or sub-directory (use your antivirus wildcard convention)
- The folder where you store Service Packs and patches.

Avaya recommends the following guidelines for antivirus software:

- Install antivirus software on the email server to ensure that problems are identified at source.
- Several maintenance tasks are automatically activated at 12:00 midnight. Therefore, you must schedule virus scans at a time other than midnight.
- Agent computers require antivirus software to ensure that attachments sent to Avaya Oceana® Omnichannel server do not have a virus. Avaya Oceana® Omnichannel does not block specific attachment file types. Install third-party antivirus software on the Portal Server according to guidelines in this document for such utilities.
- You must not enable the Microsoft Updater to Auto-Run. Microsoft Updater is configured to alert level so that you can schedule updates for off-peak hours.
- Avaya recommends that you exclude all `cache.dat` files, journal files, the `cache.cpf` file, and any Caché-related files from antivirus scans during runtime. However, when running antivirus scans during a Contact Center service outage, it is not required that you exclude these files.
- Avaya recommends that you disable McAfee Endpoint Security, or any antivirus software you have installed, while you install or upgrade the Avaya Oceana® OnmiChannel software. Re-enable the antivirus software after you complete the installation or upgrade.

# Chapter 9: Licensing requirements

---

## Infrastructure system package

Avaya Oceana® has a base license named the Infrastructure System Package. This license enables all the basic functionality and snap-ins and components required for the solution to function for the duration of the subscription term. In addition to the base license, concurrent user licenses are required for every agent and supervisor roles. The user license depends on the respective roles and their features or capabilities in the contact center environment. For example, an agent user is licensed based on the channels the agent is configured to receive. In Avaya Oceana®, concurrent supervisors are also licensed.

---

## Product licensing and delivery system

Avaya Oceana® is licensed through the Avaya's Product License Delivery System (PLDS)

For more information about PLDS, including training, documentation, and job aids, see <https://plds.avaya.com>

Avaya Control Manager licenses follow a manual process and you must request the same by using [licenseadmin@avaya.com](mailto:licenseadmin@avaya.com)

---

## Avaya Workspaces for Avaya Oceana® licensing

Avaya Workspaces is a licensed component of Avaya Oceana®.

For customers using Avaya deskphones, Avaya Workspaces is provided as an entitlement of Avaya Oceana®.

For customers using an Avaya soft phone or a non-Avaya deskphone, Avaya Workspaces is charged additionally for every agent.

---

## WebLM

Avaya provides a web-based license manager (WebLM) to manage licenses of one or more Avaya software products.

To track and manage licenses in an organization, WebLM requires a license file from the Avaya Product Licensing and Delivery System (PLDS) website at <https://plds.avaya.com>.

The license file is in XML format and contains information about the product such as the licensed capacities of each feature that you purchase. You must activate the license file in PLDS and install the license file on the WebLM server. You must run WebLM as a separate VMware virtual machine or use the WebLM running on System Manager.

---

## Upgrade Advantage Preferred

You must subscribe to Upgrade Advantage Preferred to receive major software upgrades when they become available during your contract term. This offer provides investment protection for your communications systems. Use it to reduce risks and costs, and meet business objectives by staying up-to-date with the latest technologies in a predictable operating expense model. Upgrade Advantage subscription includes:

- New and additional licenses
- Upgrading of base licenses
- Moving, merging, and un-parking of licenses

# Chapter 10: Resources

## Documentation

Title	Use this document to:	Audience
Overview		
<i>Avaya Oceana<sup>®</sup> Solution Description</i>	Know about tested product characteristics and capabilities, including product overview and feature descriptions, interoperability, performance specifications, security, and licensing requirements.	<ul style="list-style-type: none"> <li>• Sales engineers</li> <li>• Business partners</li> <li>• Solution architects</li> <li>• Implementation engineers</li> </ul>
Implementing		
<i>Deploying Avaya Oceana<sup>®</sup></i>	Deploy Avaya Oceana <sup>®</sup> .	<ul style="list-style-type: none"> <li>• Sales engineers</li> <li>• Business partners</li> <li>• Solution architects</li> <li>• Implementation engineers</li> </ul>
<i>Avaya Oceana<sup>®</sup> and Avaya Analytics<sup>™</sup> Disaster Recovery</i>	Know about how to restore Avaya Oceana <sup>®</sup> when a complete outage at the primary data center.	<ul style="list-style-type: none"> <li>• Sales engineers</li> <li>• Business partners</li> <li>• Solution architects</li> <li>• Implementation engineers</li> </ul>
<i>Upgrading Avaya Oceana<sup>®</sup></i>	Upgrade Avaya Oceana <sup>®</sup> .	<ul style="list-style-type: none"> <li>• Sales engineers</li> <li>• Business partners</li> <li>• Solution architects</li> <li>• Implementation engineers</li> </ul>
<i>Deploying Avaya Analytics<sup>™</sup></i>	Deploy Avaya Analytics <sup>™</sup> .	<ul style="list-style-type: none"> <li>• Sales engineers</li> <li>• Business partners</li> <li>• Solution architects</li> <li>• Implementation engineers</li> </ul>
Administering		

*Table continues...*

Title	Use this document to:	Audience
<i>Administering Avaya Oceana®</i>	Administer Avaya Oceana®.	<ul style="list-style-type: none"> <li>• System administrators</li> <li>• Supervisors</li> </ul>
Using		
<i>Using Avaya Workspaces for Avaya Oceana®</i>	Use Avaya Workspaces for Avaya Oceana®.	<ul style="list-style-type: none"> <li>• Agents</li> <li>• Supervisors</li> </ul>
<i>Using Avaya Analytics™</i>	Use the features and capabilities of Avaya Analytics™.	<ul style="list-style-type: none"> <li>• Supervisors</li> <li>• Administrators</li> <li>• Report designers</li> </ul>
<i>Avaya Analytics™ Data Dictionary</i>	Use historical and real-time measures in custom reports.	<ul style="list-style-type: none"> <li>• Administrators</li> <li>• Report designer</li> </ul>
Maintaining and Troubleshooting		
<i>Maintaining and Troubleshooting Avaya Oceana®</i>	Perform maintenance and troubleshooting procedures for routine maintenance and troubleshooting of Avaya Oceana®.	<ul style="list-style-type: none"> <li>• Support personnel</li> <li>• Implementation engineers</li> <li>• Administrators</li> </ul>
<i>Maintaining and Troubleshooting Avaya Analytics™</i>	Perform common maintenance functions of Avaya Analytics™ and use tools and utilities for troubleshooting of Avaya Analytics™.	<ul style="list-style-type: none"> <li>• Support personnel</li> <li>• Implementation engineers</li> <li>• Administrators</li> </ul>
<i>Avaya Oceana® Alarms</i>	View details about Avaya Oceana® alarms.	<ul style="list-style-type: none"> <li>• Support personnel</li> <li>• Administrators</li> </ul>

## Finding documents on the Avaya Support website

### Procedure

1. Go to <https://support.avaya.com>.
2. At the top of the screen, type your username and password and click **Login**.
3. Click **Support by Product > Documents**.
4. In **Enter your Product Here**, type the product name and then select the product from the list.
5. In **Choose Release**, select the appropriate release number.  
The **Choose Release** field is not available if there is only one release for the product.
6. In the **Content Type** filter, click a document type, or click **Select All** to see a list of all available documents.

For example, for user guides, click **User Guides** in the **Content Type** filter. The list only displays the documents for the selected category.

7. Click **Enter**.

---

## Avaya Documentation Center navigation

For some programs, the latest customer documentation is now available on the Avaya Documentation Center website at <https://documentation.avaya.com>.

### **Important:**

For documents that are not available on Avaya Documentation Center, click **More Sites > Support** on the top menu to open <https://support.avaya.com>.



Using the Avaya Documentation Center, you can:

- Search for keywords.

To filter by product, click **Filters** and select a product.

- Search for documents.

From **Products & Solutions**, select a solution category and product, and then select the appropriate document from the list.

- Sort documents on the search results page.
- Click **Languages** (  ) to change the display language and view localized documents.
- Publish a PDF of the current section in a document, the section and its subsections, or the entire document.
- Add content to your collection using **My Docs** (  ).

Navigate to the **Manage Content > My Docs** menu, and do any of the following:

- Create, rename, and delete a collection.
- Add topics from various documents to a collection.
- Save a PDF of the selected content in a collection and download it to your computer.
- Share content in a collection with others through email.
- Receive collection that others have shared with you.

- Add yourself as a watcher using the **Watch** icon (  ).

Navigate to the **Manage Content > Watchlist** menu, and do the following:

- Enable **Include in email notification** to receive email alerts.
- Unwatch selected content, all content in a document, or all content on the Watch list page.

As a watcher, you are notified when content is updated or deleted from a document, or the document is removed from the website.

- Share a section on social media platforms, such as Facebook, LinkedIn, and Twitter.
- Send feedback on a section and rate the content.

**\* Note:**

Some functionality is only available when you log in to the website. The available functionality depends on your role.

## Training

The following courses are available for the Avaya Oceana® program.

**Table 14: Sales Credentials**

Course code	Course title	Course duration in hours	Delivery type
APSS – 1202 Avaya IX™ Contact Center Solutions for Sales			
41510W	Avaya IX™ Contact Center Portfolio Overview (for Sales)	0.75	Web-based Training
41550T	APSS Avaya IX™ Contact Center Solutions	1.0	Web-based Training
ALCC –2005 Avaya IX™ Voice and Digital Solutions for Sales			
41710W	The Avaya IX™ Contact Center Automated Story	0.50	Web-based Training
41410W	Selling Avaya Oceana®	0.75	Web-based Training
41400W	Selling Avaya Avalytics™	0.50	Web-based Training
41480W	The Basics of Cost Justification and Selling Avaya Oceana® Using the ROI Tool	0.50	Web-based Training
41770W	Avaya Experience Portal and Proactive Outreach Manager (POM) for Sales	0.25	Web-based Training

**Table 15: Pre-Sales Design**

Course code	Course title	Course duration in hours	Delivery type
ACDS – 3480 Avaya Oceana® Design			
34210W	Avaya Oceana® Overview for Design	1.0	Web-based Training
34810W	Designing the Avaya Oceana® Part 1 of 3	1.0	Web-based Training

*Table continues...*

Course code	Course title	Course duration in hours	Delivery type
34820W	Designing the Avaya Oceana® Part 2 of 3	1.50	Web-based Training
34830W	Designing the Avaya Oceana® Part 3 of 3	1.50	Web-based Training
34800X	Avaya Oceana® Design Exam	1.50	Exam
ALRI-7001 Avaya Oceana® Product Release Information Collection			
39000W	Avaya Oceana® Release 3.8 Details for Pre-Sales	1.0	Portable Document Format (PDF)
39010W	Avaya Aalytics™ Release 3.8 and 4.1 Details for Pre-Sales	1.0	PDF
39020W	Avaya Breeze® Snap-Ins for Avaya Oceana® R3.8 Details for Pre-Sales	1.0	PDF

**Table 16: Technical Services Partner Credentials**

Course code	Course title	Course duration in hours	Delivery type
ACIS – 7495 Avaya Oceana®			
74150V	Integrating Avaya Oceana® Core and Workspaces	40.0	Virtual Instructor-Led Training
7495X	Avaya Oceana® Integration Exam	1.50	Exam
ACSS-7497 Avaya Oceana®			
74550V	Supporting Avaya Oceana®	24	Virtual Instructor-Led Training
7497X	Avaya Oceana® Support Exam	1.75	Exam
ACSS-7498 Avaya Analytics™ Insights			
74360V	Integrating and Supporting Avaya Analytics™ R4	40.0	Virtual Instructor-Led Training
74980X	Avaya Analytics™ Insights Integration and Support Exam	1.75	Exam

**Table 17: Pre-requisite Courseware**

Course code	Course title	Course duration in hours	Delivery type
77900W	Avaya Control Manager Training Bundle (5 courses 21900W, 77910W, 77920W, 77930W, 77940W)	5.50	Web-based Training
70160W	Avaya Breeze® Implementation and Support	30.0	Web-based Training

**Table 18: End User, Programmer, Administration**

<b>Avaya Learning Center</b>				
<b>Course code</b>	<b>Course title</b>	<b>Course duration in hours</b>	<b>Delivery type</b>	<b>Vanity Link for Attachment</b>
<b>ALEU-5002 Avaya Oceana® End-User Training</b>				
24020W	Using Avaya Workspaces for Avaya Oceana® - Agent	1.0	Web-based Training	<a href="https://www.avaya.com/oceana-agent">https://www.avaya.com/oceana-agent</a>
24040W	Using Avaya Workspaces for Avaya Oceana® - Supervisor	1.0	Web-based Training	<a href="https://www.avaya.com/oceana-supervisor">https://www.avaya.com/oceana-supervisor</a>
<b>ALUC-4001 Avaya Breeze® Client SDK</b>				
2410W	Customer Communications and Apps with Oceana® for Developers	3.0	Web-based Training	
<b>ASDC-0010 Avaya Workspaces® Framework</b>				
24150W	Creating Avaya Oceana® Workspaces Framework for Developers	2.0	Web-based Training	
24150W	Avaya Workspaces Framework R3 Test	1.0	Online Test	
<b>ASAC-0010 Avaya Oceana® Administration</b>				
21160W	Avaya Oceana® Fundamentals	0.5	Web-based Training	
24300V	Avaya Oceana® Administration Training	40.0	Virtual Instructor-Led Training	Attached with the sale
24300T	Administering Avaya Oceana® R3 Online Test	1.0	Online Test	
24320W	Administering Avaya Oceana® - Basic	2.5	Web-based Training	<a href="https://www.avaya.com/Oceana-admin">https://www.avaya.com/Oceana-admin</a>
<b>ASAC-0022 Administering Avaya Analytic™ for Avaya Oceana®</b>				
24380W	Administering Avaya Analytics™ for Oceana®	1.5	Web-based Training	<a href="https://www.avaya.com/Oceana-analyticsadmin">https://www.avaya.com/Oceana-analyticsadmin</a>
24310T	Administering Avaya Analytics™ R3 for Oceana® Basic Online Teat	1.0	Web-based Training	

**Table 19: Other Miscellaneous Courseware**

Course code	Course title	Course duration in hours	Delivery type	Vanity Link for Attachment
ALCC-0001 Avaya Workforce Optimization Select Integration with Avaya Oceana® Workspaces				
7014W	Integrating Avaya Workforce Optimization Select with Avaya Oceana® Workspaces	3.0	Web-based Training	
7014A	Avaya Workforce Optimization Select with Avaya Oceana® Workspaces Integration Assessment	1.0	Assessment	
70170W	Integrating Avaya Workspaces with Avaya Aura Call Center Elite	1.0	Web-based Training	
70170T	Avaya Workspaces for Elite Integration Online Test	1.0	Online Test	
71610W	Integrating POM with Avaya Oceana®	1.0	Web-based Training	
71610T	Proactive Outreach Manager with Avaya Oceana® Integration Online Test	1.0	Online Test	
ALEU-5005 Avaya Workspaces for Elite End User				
24120W	Using Avaya Workspaces for Elite – Agents	0.75	Web-based Training	<a href="https://www.avaya.com/elite-workspaces-agent">https://www.avaya.com/elite-workspaces-agent</a>
24140W	Using Avaya Workspaces for Elite – Supervisor	0.50	Web-based Training	<a href="https://www.avaya.com/elite-workspaces-supervisor">https://www.avaya.com/elite-workspaces-supervisor</a>

---

## Support

Go to the Avaya Support website at <https://support.avaya.com> for the most up-to-date documentation, product notices, and knowledge articles. You can also search for release notes, downloads, and resolutions to issues. Use the online service request system to create a service request. Chat with live agents to get answers to questions, or request an agent to connect you to a support team if an issue requires additional expertise.

# Index

## Special Characters

`_REPLACE THIS TEXT, OR DELETE THIS ENTIRE INDEXTERM ELEMENT IF YOU DO NOT NEED IT` ..... [10](#)

## A

accounts	
account type	<a href="#">76</a>
account value	<a href="#">76</a>
accounts support	<a href="#">76</a>
add agent	<a href="#">98</a>
address book	<a href="#">100</a>
LDAP	<a href="#">95</a>
agent monitoring	<a href="#">101</a>
agent state	<a href="#">102</a>
Analytics non-HA deployment	<a href="#">134</a>
antivirus software	<a href="#">141</a>
architecture	<a href="#">25</a> , <a href="#">46</a>
attribute set	<a href="#">41</a> , <a href="#">42</a>
Attribute-based Matching	<a href="#">36</a>
attribute-based routing	<a href="#">54</a>
authentication	<a href="#">17</a>
authentication between outbound connector and omnichannel resource connector	<a href="#">85</a>
auto answer	<a href="#">97</a>
aux gaming prevention	<a href="#">46</a>
Avaya Analytics architecture	<a href="#">48</a>
Avaya Analytics components	<a href="#">49</a>
Avaya Analytics non-High Availability architecture	<a href="#">48</a>
Avaya co-browsing snap-in	<a href="#">98</a>
Avaya support website	<a href="#">151</a>
Avaya Web Gateway	<a href="#">55</a>
AWFOS	<a href="#">55</a> , <a href="#">65</a>

## B

barge	<a href="#">102</a>
blended agents	<a href="#">93</a>

## C

call profile reports	<a href="#">105</a>
Callback Assist	<a href="#">56</a>
cancel	<a href="#">45</a>
cancel request	<a href="#">45</a>
capacity	<a href="#">114</a>
centralized logging	<a href="#">57</a>
channel exclusivity	<a href="#">58</a>
channel identifiers	<a href="#">74</a>
client SDK	<a href="#">47</a>
clusters	<a href="#">31</a>

Co-Browsing Snap-in	<a href="#">140</a>
Fulfillment of Data Subject Rights	<a href="#">140</a>
Privacy by Default	<a href="#">140</a>
Security of Processing	<a href="#">140</a>
Storage of Personal Data	<a href="#">140</a>
collection	
delete	<a href="#">147</a>
edit name	<a href="#">147</a>
generating PDF	<a href="#">147</a>
sharing content	<a href="#">147</a>
Common Services overview	<a href="#">23</a>
compare workflow	<a href="#">35</a>
components	<a href="#">27</a> , <a href="#">47</a> , <a href="#">50</a>
conference	<a href="#">102</a>
consult	<a href="#">97</a>
contact dispositions	<a href="#">74</a>
content	
publishing PDF output	<a href="#">147</a>
searching	<a href="#">147</a>
sharing	<a href="#">147</a>
sort by last updated	<a href="#">147</a>
watching for updates	<a href="#">147</a>
CRMGateway	<a href="#">76</a>
custom chatbot	
IBM Watson	<a href="#">65</a>
customer channel	<a href="#">76</a>
customer contact ratio	<a href="#">119</a>
customer information	<a href="#">76</a>
customer journey	<a href="#">98</a>

## D

dashboards	
Avaya Analytics	<a href="#">106</a>
real-time	<a href="#">92</a> , <a href="#">110</a>
data	<a href="#">59</a>
data partitioning	<a href="#">58</a>
default resource proficiency	<a href="#">43</a>
defer email	<a href="#">60</a> , <a href="#">101</a>
delete local users	<a href="#">15</a>
deployment modes	<a href="#">61</a>
deployment spreadsheet	<a href="#">16</a>
derived proficiency	<a href="#">43</a>
design	<a href="#">88</a>
disk	<a href="#">124</a> , <a href="#">130</a>
disposition codes	<a href="#">100</a>
document changes	<a href="#">10</a>
documentation center	<a href="#">147</a>
finding content	<a href="#">147</a>
navigation	<a href="#">147</a>
documentation portal	<a href="#">147</a>
finding content	<a href="#">147</a>
navigation	<a href="#">147</a>

DR monitoring tool .....	<a href="#">112</a>	MatchType .....	<a href="#">42</a>
DR Monitoring Tool .....	<a href="#">16</a>	maximum accounts .....	<a href="#">114</a>
<b>E</b>		maximum active users .....	<a href="#">114</a>
EASG authentication .....	<a href="#">138</a>	measures	
Engagement Designer workflows .....	<a href="#">35</a>	assigning thresholds .....	<a href="#">92</a> , <a href="#">106</a>
ESXi hosts .....	<a href="#">80</a>	memory .....	<a href="#">124</a> , <a href="#">130</a>
Export and import of multiple workflows .....	<a href="#">61</a>	most idle .....	<a href="#">43</a>
extensibility .....	<a href="#">93</a>	multiple browsers .....	<a href="#">94</a>
External transcript access .....	<a href="#">61</a>	multiple customer search parameters .....	<a href="#">100</a>
		multiple resources .....	<a href="#">41</a>
		multiplicity .....	<a href="#">44</a>
		My Docs .....	<a href="#">147</a>
<b>F</b>		<b>N</b>	
finding content on documentation center .....	<a href="#">147</a>	New in Oceana 3.8.1 .....	<a href="#">10</a>
full database backup .....	<a href="#">15</a>	New in Oceana Release 3.8.1 .....	<a href="#">10</a>
functionality .....	<a href="#">36</a>	notices legal .....	
<b>G</b>		<b>O</b>	
GDPR compliance		observe .....	<a href="#">101</a>
Social Media .....	<a href="#">140</a>	Oceana base license .....	<a href="#">143</a>
ZangSmsConnector .....	<a href="#">140</a>	Oceana license .....	<a href="#">143</a>
greatest need .....	<a href="#">43</a>	Oceana PLDS .....	<a href="#">143</a>
group of resources .....	<a href="#">42</a>	Oceana Release 3.8.1	
<b>H</b>		enhancements .....	<a href="#">10</a>
hardware .....	<a href="#">124</a> , <a href="#">130</a>	new features .....	<a href="#">10</a>
hardware specifications .....	<a href="#">130</a>	Oceana transcriptsT	
high availability .....	<a href="#">62</a>	authorized access .....	<a href="#">55</a>
Historical reporting local users .....	<a href="#">15</a>	Omnichannel performance .....	<a href="#">119</a>
hold interaction .....	<a href="#">96</a>	omnichannel resource connector .....	<a href="#">17</a>
<b>I</b>		online help for OCP application .....	<a href="#">11</a>
Inbound MMS .....	<a href="#">13</a>	operating system .....	<a href="#">130</a>
interactions .....	<a href="#">97</a>	outbound .....	<a href="#">34</a>
interface .....	<a href="#">89</a>	outbound connector .....	<a href="#">17</a>
intuitive UX for agents .....	<a href="#">65</a>	overview .....	<a href="#">19</a> , <a href="#">36</a>
intuitive UX for supervisors .....	<a href="#">65</a>	Avaya Analytics .....	<a href="#">22</a>
<b>L</b>		Avaya Control Manager .....	<a href="#">28</a>
last agent routing .....	<a href="#">79</a>	Avaya Workspaces .....	<a href="#">20</a>
least occupied .....	<a href="#">43</a>	<b>P</b>	
legal notices .....		partial team .....	<a href="#">42</a>
licensing requirements .....	<a href="#">143</a>	platform .....	<a href="#">30</a>
limitations of second chance IVR .....	<a href="#">73</a>	Post Call Survey .....	<a href="#">70</a>
<b>M</b>		Private key encryption .....	<a href="#">15</a>
mail approval .....	<a href="#">103</a>	Private key storage .....	<a href="#">15</a>
match update		proficiency .....	<a href="#">43</a>
single resource .....	<a href="#">39</a>	proficiency range .....	<a href="#">46</a>
		purpose .....	<a href="#">10</a>
		<b>Q</b>	
		query metrics .....	<a href="#">37</a>
		query resources .....	<a href="#">45</a>

**R**

ratio of customers to contacts .....	<a href="#">119</a>
receive interactions .....	<a href="#">96</a>
reject .....	<a href="#">45</a>
related documentation .....	<a href="#">145</a>
remote backup .....	<a href="#">15</a>
Remote backup .....	<a href="#">111</a>
reporting	
historical .....	<a href="#">105</a>
real-time .....	<a href="#">106</a>
reports	
Avaya Analytics .....	<a href="#">106</a>
request resource .....	<a href="#">39</a>
reset password .....	<a href="#">15</a>
resource request .....	<a href="#">42</a>
resource selection .....	<a href="#">43</a>
resume interaction .....	<a href="#">96</a>

**S**

SAL policy server .....	<a href="#">138</a>
screenpops .....	<a href="#">99</a>
search customer history .....	<a href="#">100</a>
searching for content .....	<a href="#">147</a>
second chance IVR .....	<a href="#">73</a>
second chance IVR flow .....	<a href="#">73</a>
secure communication .....	<a href="#">139</a>
security .....	<a href="#">137</a>
selection strategy .....	<a href="#">43, 44</a>
service .....	<a href="#">97</a>
service excluded .....	<a href="#">44</a>
service metrics .....	<a href="#">37</a>
Service Rank .....	<a href="#">40</a>
sharing content .....	<a href="#">147</a>
single resource .....	<a href="#">39</a>
single sign-on .....	<a href="#">95</a>
skill level .....	<a href="#">43</a>
SMS .....	<a href="#">67</a>
SNMP .....	<a href="#">75</a>
social messaging platforms .....	<a href="#">14</a>
SocialConnector	
Privacy by Default .....	<a href="#">139</a>
Security of Processing .....	<a href="#">139</a>
sort documents by last updated .....	<a href="#">147</a>
specifications	
hardware and software .....	<a href="#">120</a>
specified resources .....	<a href="#">40</a>
start work .....	<a href="#">95</a>
supervisor .....	<a href="#">97</a>
supervisor reporting dashboard .....	<a href="#">89</a>
user management .....	<a href="#">91</a>
support .....	<a href="#">151</a>
handling browser close .....	<a href="#">78</a>
network connection issues .....	<a href="#">78</a>

**T**

thin provisioning	
VMware disk storage .....	<a href="#">134</a>
thresholds .....	<a href="#">79</a>
time after contact work .....	<a href="#">99</a>
TLS .....	<a href="#">138</a>
training .....	<a href="#">148</a>
transfer .....	<a href="#">102</a>
transfer operations .....	<a href="#">97</a>
transfer to service .....	<a href="#">94</a>
Troubleshooting replication and failover .....	<a href="#">112</a>

**U**

Upgrade Advantage Preferred .....	<a href="#">144</a>
upgrade and migration .....	<a href="#">135</a>
upgrading	
Cluster Control Manager .....	<a href="#">16</a>
Cluster Control Manager for offline deployment .....	<a href="#">16</a>
requirements .....	<a href="#">144</a>
Upgrading Physical hosts running Avaya Analytics .....	<a href="#">85</a>
Upscaling Avaya Analytics .....	<a href="#">14</a>
Upscaling Avaya Analytics Overview .....	<a href="#">111</a>
user .....	<a href="#">97</a>

**V**

vCPU .....	<a href="#">124, 130</a>
view local users .....	<a href="#">15</a>
views	
assigning thresholds .....	<a href="#">92, 106</a>
Virtual machine .....	<a href="#">80</a>
VMware 7.0 .....	<a href="#">15</a>
VMware configuration .....	<a href="#">80</a>
VMWare configuration .....	<a href="#">80</a>
Voice .....	<a href="#">67</a>
voice calls .....	<a href="#">96</a>
voice self service .....	<a href="#">34</a>

**W**

watch list .....	<a href="#">147</a>
web clients .....	<a href="#">85</a>
web servers .....	<a href="#">85</a>
web video .....	<a href="#">34</a>
web voice .....	<a href="#">34</a>
WebLM .....	<a href="#">144</a>
Windows Server 2016 .....	<a href="#">142</a>
work code recording .....	<a href="#">98</a>
work selection strategy .....	<a href="#">43</a>
WORK_UNFULFILLED .....	<a href="#">41, 42</a>
workflow design .....	<a href="#">94</a>

## Z

ZangSmsConnector	
Privacy by Default .....	<a href="#">140</a>
Security of Processing .....	<a href="#">140</a>
zero footprint .....	<a href="#">88</a>