



# IP Office™ Platform 12.0

Deploying an IP500 V2 IP Office  
Essential Edition System

#### Notice

While reasonable efforts have been made to ensure that the information in this document is complete and accurate at the time of printing, Avaya assumes no liability for any errors. Avaya reserves the right to make changes and corrections to the information in this document without the obligation to notify any person or organization of such changes.

#### Documentation disclaimer

"Documentation" means information published in varying media which may include product information, subscription or service descriptions, operating instructions and performance specifications that are generally made available to users of products. Documentation does not include marketing materials. Avaya shall not be responsible for any modifications, additions, or deletions to the original published version of Documentation unless such modifications, additions, or deletions were performed by or on the express behalf of Avaya. End user agrees to indemnify and hold harmless Avaya, Avaya's agents, servants and employees against all claims, law suits, demands and judgments arising out of, or in connection with, subsequent modifications, additions or deletions to this documentation, to the extent made by End user.

#### Link disclaimer

Avaya is not responsible for the contents or reliability of any linked websites referenced within this site or Documentation provided by Avaya. Avaya is not responsible for the accuracy of any information, statement or content provided on these sites and does not necessarily endorse the products, services, or information described or offered within them. Avaya does not guarantee that these links will work all the time and has no control over the availability of the linked pages.

#### Warranty

Avaya provides a limited warranty on Avaya hardware and software. Please refer to your agreement with Avaya to establish the terms of the limited warranty. In addition, Avaya's standard warranty language as well as information regarding support for this product while under warranty is available to Avaya customers and other parties through the Avaya Support website: <https://support.avaya.com/helpcenter/getGenericDetails?detailId=C20091120112456651010> under the link "Warranty & Product Lifecycle" or such successor site as designated by Avaya. Please note that if the product(s) was purchased from an authorized Avaya channel partner outside of the United States and Canada, the warranty is provided by said Avaya Channel Partner and not by Avaya.

"Hosted Service" means an Avaya hosted service subscription that You acquire from either Avaya or an authorized Avaya Channel Partner (as applicable) and which is described further in Hosted SAS or other service description documentation regarding the applicable hosted service. If You purchase a Hosted Service subscription, the foregoing limited warranty may not apply but You may be entitled to support services in connection with the Hosted Service as described further in your service description documents for the applicable Hosted Service. Contact Avaya or Avaya Channel Partner (as applicable) for more information.

#### Hosted Service

THE FOLLOWING APPLIES ONLY IF YOU PURCHASE AN AVAYA HOSTED SERVICE SUBSCRIPTION FROM AVAYA OR AN AVAYA CHANNEL PARTNER (AS APPLICABLE), THE TERMS OF USE FOR HOSTED SERVICES ARE AVAILABLE ON THE AVAYA WEBSITE, [HTTPS://SUPPORT.AVAYA.COM/LICENSEINFO](https://support.avaya.com/licenseinfo) UNDER THE LINK "Avaya Terms of Use for Hosted Services" OR SUCH SUCCESSOR SITE AS DESIGNATED BY AVAYA, AND ARE APPLICABLE TO ANYONE WHO ACCESSES OR USES THE HOSTED SERVICE. BY ACCESSING OR USING THE HOSTED SERVICE, OR AUTHORIZING OTHERS TO DO SO, YOU, ON BEHALF OF YOURSELF AND THE ENTITY FOR WHOM YOU ARE DOING SO (HEREINAFTER REFERRED TO INTERCHANGEABLY AS "YOU" AND "END USER"), AGREE TO THE TERMS OF USE. IF YOU ARE ACCEPTING THE TERMS OF USE ON BEHALF A COMPANY OR OTHER LEGAL ENTITY, YOU REPRESENT THAT YOU HAVE THE AUTHORITY TO BIND SUCH ENTITY TO THESE TERMS OF USE. IF YOU DO NOT HAVE SUCH AUTHORITY, OR IF YOU DO NOT WISH TO ACCEPT THESE TERMS OF USE, YOU MUST NOT ACCESS OR USE THE HOSTED SERVICE OR AUTHORIZE ANYONE TO ACCESS OR USE THE HOSTED SERVICE.

#### Licenses

The Global Software License Terms ("Software License Terms") are available on the following website <https://www.avaya.com/en/legal-license-terms/> or any successor site as designated by Avaya. These Software License Terms are applicable to anyone who installs, downloads, and/or uses Software and/or Documentation. By installing, downloading or using the Software, or authorizing others to do so, the end user agrees that the Software License Terms create a binding contract between them and Avaya. In case the end user is accepting these Software License Terms on behalf of a company or other legal entity, the end user represents that it has the authority to bind such entity to these Software License Terms.

#### Copyright

Except where expressly stated otherwise, no use should be made of materials on this site, the Documentation, Software, Hosted Service, or hardware provided by Avaya. All content on this site, the documentation, Hosted Service, and the product provided by Avaya including the selection, arrangement and design of the content is owned either by Avaya or its licensors and is protected by copyright and other intellectual property laws including the sui generis rights relating to the protection of databases. You may not modify, copy, reproduce, republish, upload, post, transmit or distribute in any way any content, in whole or in part, including any code and software unless expressly authorized by Avaya. Unauthorized reproduction, transmission, dissemination, storage, and/or use without the express written consent of Avaya can be a criminal, as well as a civil offense under the applicable law.

#### Virtualization

The following applies if the product is deployed on a virtual machine. Each product has its own ordering code and license types. Unless otherwise stated, each Instance of a product must be separately licensed and ordered. For example, if the end user customer or Avaya Channel Partner would like to install two Instances of the same type of products, then two products of that type must be ordered.

### Third Party Components

The following applies only if the H.264 (AVC) codec is distributed with the product. THIS PRODUCT IS LICENSED UNDER THE AVC PATENT PORTFOLIO LICENSE FOR THE PERSONAL USE OF A CONSUMER OR OTHER USES IN WHICH IT DOES NOT RECEIVE REMUNERATION TO: (i) ENCODE VIDEO IN COMPLIANCE WITH THE AVC STANDARD ("AVC VIDEO") AND/OR (ii) DECODE AVC VIDEO THAT WAS ENCODED BY A CONSUMER ENGAGED IN A PERSONAL ACTIVITY AND/OR WAS OBTAINED FROM A VIDEO PROVIDER LICENSED TO PROVIDE AVC VIDEO. NO LICENSE IS GRANTED OR SHALL BE IMPLIED FOR ANY OTHER USE. ADDITIONAL INFORMATION MAY BE OBTAINED FROM MPEG LA, L.L.C. SEE [HTTP://WWW.MPEGLA.COM](http://www.mpegla.com).

### Service Provider

WITH RESPECT TO CODECS, IF THE AVAYA CHANNEL PARTNER IS HOSTING ANY PRODUCTS THAT USE OR EMBED THE H.264 CODEC OR H.265 CODEC, THE AVAYA CHANNEL PARTNER ACKNOWLEDGES AND AGREES THE AVAYA CHANNEL PARTNER IS RESPONSIBLE FOR ANY AND ALL RELATED FEES AND/OR ROYALTIES. THE H.264 (AVC) CODEC IS LICENSED UNDER THE AVC PATENT PORTFOLIO LICENSE FOR THE PERSONAL USE OF A CONSUMER OR OTHER USES IN WHICH IT DOES NOT RECEIVE REMUNERATION TO: (i) ENCODE VIDEO IN COMPLIANCE WITH THE AVC STANDARD ("AVC VIDEO") AND/OR (ii) DECODE AVC VIDEO THAT WAS ENCODED BY A CONSUMER ENGAGED IN A PERSONAL ACTIVITY AND/OR WAS OBTAINED FROM A VIDEO PROVIDER LICENSED TO PROVIDE AVC VIDEO. NO LICENSE IS GRANTED OR SHALL BE IMPLIED FOR ANY OTHER USE. ADDITIONAL INFORMATION FOR H.264 (AVC) AND H.265 (HEVC) CODECS MAY BE OBTAINED FROM MPEG LA, L.L.C. SEE [HTTP://WWW.MPEGLA.COM](http://www.mpegla.com).

### Compliance with Laws

You acknowledge and agree that it is Your responsibility for complying with any applicable laws and regulations, including, but not limited to laws and regulations related to call recording, data privacy, intellectual property, trade secret, fraud, and music performance rights, in the country or territory where the Avaya product is used.

### Preventing Toll Fraud

"Toll Fraud" is the unauthorized use of your telecommunications system by an unauthorized party (for example, a person who is not a corporate employee, agent, subcontractor, or is not working on your company's behalf). Be aware that there can be a risk of Toll Fraud associated with your system and that, if Toll Fraud occurs, it can result in substantial additional charges for your telecommunications services.

### Avaya Toll Fraud intervention

If You suspect that You are being victimized by Toll Fraud and You need technical assistance or support, please contact your Avaya Sales Representative.

### Security Vulnerabilities

Information about Avaya's security support policies can be found in the Security Policies and Support section of <https://support.avaya.com/security>.

Suspected Avaya product security vulnerabilities are handled per the Avaya Product Security Support Flow (<https://support.avaya.com/css/P8/documents/100161515>).

### Trademarks

The trademarks, logos and service marks ("Marks") displayed in this site, the Documentation, Hosted Service(s), and product(s) provided by Avaya are the registered or unregistered Marks of Avaya, its affiliates, its licensors, its suppliers, or other third parties. Users are not permitted to use such Marks without prior written consent from Avaya or such third party which may own the Mark. Nothing contained in this site, the Documentation, Hosted Service(s) and product(s) should be construed as granting, by implication, estoppel, or otherwise, any license or right in and to the Marks without the express written permission of Avaya or the applicable third party.

Avaya is a registered trademark of Avaya LLC.

All non-Avaya trademarks are the property of their respective owners.

Linux® is the registered trademark of Linus Torvalds in the U.S. and other countries.

### Downloading Documentation

For the most current versions of Documentation, see the Avaya Support website: <https://support.avaya.com>, or such successor site as designated by Avaya.

### Contact Avaya Support

See the Avaya Support website: <https://support.avaya.com> for Product or Cloud Service notices and articles, or to report a problem with your Avaya Product or Cloud Service. For a list of support telephone numbers and contact addresses, go to the Avaya Support website: <https://support.avaya.com> (or such successor site as designated by Avaya), scroll to the bottom of the page, and select Contact Avaya Support.

# Contents

## 1. IP500 V2 Overview

1.1 Additional Documentation.....	11
1.2 Technical Specifications.....	11
1.3 Equipment Availability.....	13
1.4 Repair .....	13
1.5 RoHS .....	13
1.6 IP Office Modes.....	14
1.6.1 System SD Cards .....	14
1.6.2 Overall Capacity.....	15
1.6.3 Hardware Support Summary.....	16
1.6.4 Feature Support Summary.....	17
1.6.5 Supported Country Locales .....	17
1.7 IP500 V2 System Components.....	19
1.8 System SD Card.....	21
1.9 Licensing .....	22
1.10 Control Unit Cards.....	23
1.10.1 IP500 Base Cards .....	23
1.10.2 IP500 Trunk Cards .....	25
1.11 External Expansion Modules.....	26
1.11.1 IP500 External Expansion Modules .....	27
1.11.2 IP400 External Expansion Modules .....	28
1.11.3 Connecting External Expansion Modules.....	29
1.12 Power Supplies and Cables .....	30
1.12.1 Power Supplies.....	30
1.12.2 Power Supply Cords .....	31
1.12.3 Power Supply Backup.....	32
1.12.4 Cabling and Cables.....	33
1.12.5 Grounding .....	35
1.12.6 Lightning Protection/Out-of-Building Connections.....	36
1.13 Wall and Rack Mounting.....	37
1.13.1 Wall Mounting Kits.....	37
1.13.2 Rack Mounting Kits.....	38
1.14 IP Office Phones .....	39
1.15 VoIP/IP Telephony.....	40
1.15.1 Voice Compression Channels .....	41
1.16 IP Office Software Applications .....	42
1.16.1 Programming Applications.....	43
1.16.2 User Applications .....	44
1.16.3 Voicemail Applications .....	44
1.16.4 Call Logging Applications.....	45
1.16.5 Call Center Applications.....	45
1.16.6 CTI Applications.....	45
1.17 Training .....	46
1.18 Web Sites .....	46
1.19 Emergency and Power Failure Ports.....	47

## 2. Installation Overview

2.1 Environmental Requirements.....	51
2.2 Space Requirements.....	53
2.2.1 Control Unit.....	53
2.2.2 External Expansion Modules .....	54
2.2.3 Wall Mounting.....	56
2.2.4 Rack Space Requirements.....	59
2.3 Tools and Parts Required.....	61

2.4 Documentation.....	62
2.5 Unpacking .....	63

## 3. Installing the Administrator Software

3.1 Downloading the Software.....	67
3.2 Installing the Administrator Applications.....	68
3.3 Installer PC Connection.....	70
3.4 Starting IP Office Manager.....	71
3.5 Starting the System Status Application.....	72
3.6 Starting System Monitor.....	73
3.7 Starting IP Office Web Manager.....	74
3.8 Phone Based Administration.....	74

## 4. Preparing the System SD Card

4.1 Upgrade the Card Firmware.....	77
4.2 Creating an Offline Configuration File.....	78
4.3 Importing and Exporting Settings.....	79
4.4 Adding a Pre-Built Configuration File.....	80
4.5 Adding a License File.....	80
4.6 Adding Security Certificates .....	80
4.7 Adding a 9600 Series Screen Saver File.....	81
4.8 Adding Music on Hold Files .....	81

## 5. Installing the Control Unit Cards

5.1 Fitting IP500 Daughter Cards.....	85
5.2 Inserting IP500 Base Cards .....	86

## 6. Installing the Physical System

6.1 Wall Mounting .....	89
6.1.1 Wall Mounting Kit V3.....	90
6.2 Rack Mounting .....	91
6.3 Connecting External Expansion Modules .....	93
6.4 Grounding .....	95
6.5 Starting the System.....	96
6.6 Checking the LEDs.....	97
6.7 Connecting Phones.....	99
6.7.1 Analog Phones.....	99
6.7.2 DS Digital Station Phones.....	99
6.7.3 IP/SIP Phones.....	99

## 7. Initial Configuration using Manager

7.1 Network Connection.....	103
7.2 Initial Configuration.....	105
7.3 Extension Numbering.....	106
7.4 Disable Unused Trunks.....	107
7.5 Setting the Digital Trunk Clock Source.....	108
7.6 Setting the Trunk Prefixes .....	110
7.7 Uploading the License File.....	111
7.8 Saving the Configuration.....	112

## 8. Initial Configuration Using IP Office Web Manager

8.1 The System's Initial IP Address .....	114
8.2 Initial Configuration.....	115
8.3 Dashboard Wizard Menus .....	118
8.3.1 System Settings.....	119
8.3.2 VoIP Settings .....	121
8.3.3 Voicemail Settings.....	122

8.3.4 Licensing Settings.....	123	10.12.2 Shutdown a Card Using System Status Application.....	151
8.3.5 Users and Extensions.....	124	10.12.3 Shutdown a Card Using IP Office Web Manager .....	151
8.3.6 Groups.....	125	10.12.4 Shutdown a Card Using a System Phone....	151
8.3.7 Lines .....	126	10.13 Memory Card Startup.....	152
8.3.8 Incoming Call Routes.....	127	10.13.1 Startup a Card Using IP Office Manager.....	152
8.3.9 Outgoing Call Routes .....	128	10.13.2 Startup a Card Using System Status Application.....	152
<b>9. System Security</b>		10.13.3 Startup a Card Using IP Office Web Manager .....	152
9.1 Changing the Default Security Settings.....	131	10.13.4 Startup a Card Using a System Phone.....	152
9.2 Changing the Remote User Password.....	132	<b>11.Additional Processes</b>	
9.3 Disabling SIP Trunk Support.....	132	11.1 Adding the System Certificate to a Browser.....	155
9.4 Disabling H.323 Telephone Support.....	133	11.2 Changing a System from IP Office Basic Edition Mode .....	157
9.5 Disabling SIP Extension Support.....	133	11.3 Rerunning the Initial Configuration Utility.....	158
9.6 Adding a Certificate .....	133	11.4 Automating the Change to Standard Mode .....	159
<b>10.SD Card Management</b>		11.5 Saving the Configuration File Off-Line.....	160
10.1 Booting from the SD Cards .....	139	11.6 Switching Off a System.....	161
10.2 Creating an IP Office SD Card .....	141	11.6.1 Shutdown a System Using IP Office Manager .....	161
10.3 Viewing the Card Contents.....	143	11.6.2 Shutdown a System Using System Status Application.....	161
10.4 Backing Up to the Backup Folder.....	144	11.6.3 Shutdown a System Using a System Phone..	162
10.4.1 Backup to the Backup Folder Using IP Office Manager.....	144	11.6.4 Shutdown a System Using the AUX Button....	162
10.4.2 Backup to the Backup Folder Using System Status Application.....	144	11.6.5 Shutdown a System Using IP Office Web Manager .....	162
10.4.3 Backup to the Backup Folder Using a System Phone.....	144	11.7 Rebooting a System .....	163
10.4.4 Backup to the Backup Folder Using a IP Office Web Manager.....	144	11.7.1 Reboot a System Using IP Office Manager....	163
10.5 Restoring from the Backup Folder.....	145	11.7.2 Reboot a System Using IP Office Web Manager .....	163
10.5.1 Restoring from the Backup Folder Using IP Office Manager.....	145	11.7.3 Reboot a System Using the Reset Button.....	164
10.5.2 Restoring from the Backup Folder Using System Status Application.....	145	11.8 Changing Components .....	164
10.5.3 Restoring from the Backup Folder Using a System Phone.....	145	11.8.1 Like for Like Replacement.....	165
10.5.4 Restoring from the Backup Folder Using IP Office Web Manager.....	145	11.8.2 Higher Capacity Replacement.....	165
10.6 Backing Up to the Optional SD Card .....	146	11.8.3 Lower Capacity Replacement.....	165
10.6.1 Backing Up to the Optional SD Using IP Office Manager.....	146	11.8.4 Adding a New Component.....	165
10.6.2 Backing Up to the Optional SD Using System Status Application.....	146	11.8.5 Permanent Removal.....	166
10.6.3 Backing Up to the Optional SD Using IP Office Web Manager.....	146	11.8.6 Replacement with a Different Type.....	166
10.6.4 Backing Up to the Optional SD Using a System Phone.....	146	11.9 Defaulting the Configuration.....	167
10.7 Restoring a Configuration from an Optional Card....	147	11.9.1 Defaulting the Configuration Using IP Office Manager .....	167
10.7.1 Restoring from the Optional SD Using IP Office Manager.....	147	11.9.2 Defaulting the Configuration Using IP Office Web Manager.....	167
10.7.2 Restoring from the Optional SD Using a System Phone.....	147	11.9.3 Defaulting the Configuration Using the Reset Button.....	167
10.8 Loading Software from an Optional SD Card .....	148	11.9.4 Defaulting the Configuration Using Debug....	168
10.8.1 Loading Software from the Optional SD Using IP Office Manager.....	148	11.9.5 Defaulting the Configuration Using Boot Loader .....	169
10.8.2 Loading Software from the Optional SD Using a System Phone.....	148	11.10 Defaulting Security Settings .....	170
10.9 Backing Up to a PC.....	149	11.10.1 Defaulting Security Using IP Office Manager .....	171
10.10 Restoring from a PC.....	149	11.10.2 Defaulting Security Using IP Office Web Manager .....	171
10.11 Upgrading Card Software.....	150	11.10.3 Defaulting Security using the RS232 Port....	172
10.12 Memory Card Shutdown/Removal.....	151	11.10.4 Defaulting Security Using the Boot Loader...	173
10.12.1 Shutdown a Card Using IP Office Manager..	151	11.11 Loading a Configuration.....	174
		11.11.1 Creating an Offline Configuration File.....	175

11.11.2 Loading a Configuration Using IP Office Manager .....	176	12.7.1 IP500 Wall Mounting Kits.....	237
11.11.3 Loading a Configuration Using IP Office Web Manager.....	176	12.7.2 Rack Mounting Kit.....	237
11.11.4 Loading a Configuration onto a System SD Card .....	176	12.7.3 Barrier Box Rack Mounting Kit.....	238
11.12 Upgrading systems.....	177	12.8 Phones .....	239
11.12.1 Upgrade Using the Upgrade Wizard.....	178	12.9 Phone Button Modules.....	240
11.12.2 Locally Upgrade the SD System Card Using Manager.....	180	12.10 Applications.....	242
11.12.3 Upgrading Using an Optional SD Card.....	181	12.10.1 Avaya Call Reporting .....	243
11.12.4 Upgrading Using IP Office Web Manager.....	182	12.10.2 Avaya Contact Center Select.....	243
11.13 Swapping Extension Users .....	183	12.10.3 Embedded Voicemail.....	243
11.14 Out of Building Telephone Installations .....	184	12.10.4 Avaya Workplace Client.....	244
11.14.1 DS Phones.....	185	12.10.5 IP Office Application Server.....	245
11.14.2 Analog Phone Barrier Box.....	186	12.10.6 IP Office Manager.....	246
11.14.3 Rack Mounting Barrier Boxes .....	187	12.10.7 Media Manager.....	246
11.15 Using the External Output Port.....	188	12.10.8 IP Office Web Client.....	247
11.15.1 Port Connection.....	188	12.10.9 System Monitor.....	247
11.16 SNMP .....	189	12.10.10 one-X Portal for IP Office.....	247
11.16.1 Installing the IP Office MIB Files.....	190	12.10.11 IP Office SoftConsole.....	248
11.16.2 Enabling SNMP and Polling Support.....	192	12.10.12 System Status Application .....	248
11.16.3 Enabling SNMP Trap Sending.....	192	12.10.13 TAPI.....	249
11.17 Refreshing the System Files from Manager.....	193	12.10.14 User Portal.....	250
11.18 Reset Button.....	194	12.10.15 Voicemail Pro.....	250
11.19 AUX Button .....	194	12.10.16 IP Office Ports.....	251
11.20 RS232 Port Maintenance.....	195	12.11 Operating System Support.....	252
11.21 Erasing the Core Software.....	196	12.11.1 Windows Support.....	252
11.21.1 Erasing Core Software Using the Reset Button .....	196	12.11.2 Android Support.....	253
11.21.2 Erasing Core Software Using Debug .....	197	12.11.3 Apple Support.....	254
11.21.3 Erasing Core Software Using the Boot Loader .....	198	12.11.4 Linux Support.....	254
11.22 Enabling IP Office Web Manager.....	199	12.11.5 Browser Support.....	255
<b>12. System Components</b>		12.12 Physical Ports.....	256
12.1 IP500 V2 Control Unit.....	203	12.12.1 Cables.....	257
12.2 IP500 V2 System SD Cards .....	206	12.12.2 ANALOG Port.....	259
12.3 IP500 Base Cards.....	207	12.12.3 AUDIO Port.....	259
12.3.1 4-Port Expansion Card.....	209	12.12.4 BRI Port (So).....	260
12.3.2 Analog Phone.....	210	12.12.5 BRI Port (To).....	261
12.3.3 ATM V2 Combination Card.....	211	12.12.6 DC I/P Port.....	262
12.3.4 BRI Combination Card.....	212	12.12.7 DS Ports (RJ45).....	262
12.3.5 Digital Station (DS8/DS8A).....	213	12.12.8 EXPANSION Port.....	263
12.3.6 Unified Communications Module .....	214	12.12.9 EXT O/P Port.....	263
12.3.7 VCM V2/VCM V3.....	215	12.12.10 LAN Port.....	264
12.4 IP500 Trunk Daughter Cards.....	217	12.12.11 PF Port.....	265
12.4.1 Analog Trunk Card V2.....	218	12.12.12 PHONE (POT) Port.....	266
12.4.2 BRI Trunk Cards.....	219	12.12.13 PRI Port.....	267
12.4.3 PRI Trunk Cards.....	220	12.12.14 RS232 Port (DTE).....	268
12.5 IP500 External Expansion Modules.....	222	12.13 Licences .....	269
12.5.1 Analog Trunk 16.....	223	12.13.1 System Edition Licenses.....	269
12.5.2 DS16B/30B, DS16B2/30B2.....	226	12.13.2 Upgrade Licenses .....	270
12.5.3 Phone 16/30.....	228	12.13.3 Trunk Licensing.....	270
12.6 IP400 Expansion Modules.....	230	12.13.4 Telephone/Endpoint Licenses .....	271
12.6.1 Analog Trunk 16.....	231	12.13.5 User Licenses.....	272
12.6.2 Digital Station V2.....	233	12.13.6 Voicemail Pro Licenses.....	274
12.6.3 Phone V2.....	235	12.13.7 Trial Licenses .....	275
12.7 Mounting Kits.....	237	12.13.8 CTI Licenses.....	275
		12.13.9 Other Licenses.....	275
		12.14 Hardware/Software Compatibility.....	276
		12.14.1 Control Units and Control Unit Components.....	277
		12.14.2 Phones.....	280

---

12.14.3 Applications.....	284
12.15 PCS Levels.....	285
12.16 TAA .....	285
<b>13.Safety Statements</b>	
13.1 Lightning Protection/Hazard Symbols.....	288
13.2 Trunk Interface Modules.....	289
13.3 Further Information and Product Updates.....	290
13.4 Port Safety Classification.....	290
13.5 EMC Directive.....	291
13.6 Regulatory Instructions for Use.....	292
13.6.1 Australia .....	292
13.6.2 Canada.....	292
13.6.3 China .....	293
13.6.4 Japan.....	294
13.6.5 European Union .....	294
13.6.6 New Zealand.....	295
13.6.7 FCC Notification.....	296
13.6.8 Compliance with FCC Rules .....	298
Index .....	299



# Chapter 1.

## IP500 V2 Overview

---

# 1. IP500 V2 Overview

This document is intended to assist with the installation of an IP Office system running in IP Office Essential Edition or IP Office Preferred Edition mode on an IP500 V2 control unit. Installation in other modes is covered by separate manuals.

- Within this document, IP500 V2 refers to IP500 V2 and IP500 V2A control units unless specifically stated otherwise.

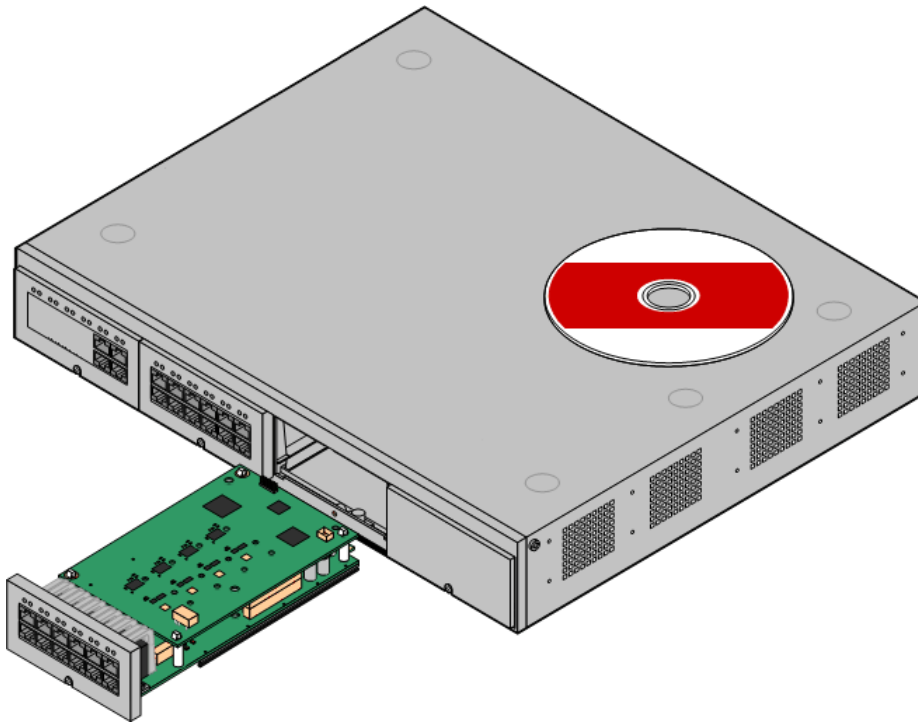

- The IP Office is a converged voice and data communications system. It should only be installed by persons with telephony and IP data network experience.
- Installers must be trained on IP Office systems. Through [Avaya Learning](#)<sup>46</sup>, Avaya provides a range of training courses including specific IP Office implementation and installation training. It also provides certification schemes for installers to achieve IP Office accreditation.
- It is the installer's responsibility to ensure that all installation work is done in accordance with local and national regulations and requirements. It is also their responsibility to accurately establish the customer's requirements before installation and to ensure that the installation meets those requirements.
- You should read and understand this documentation before installation. You should also obtain and read the Avaya Technical Bulletins relevant to recent software and hardware releases to ensure that you are familiar with any changes to the IP Office equipment and software.
- This document does not cover the addition of an IP500 V2 system as an IP500 V2 Expansion System system in a Server Edition or IP Office Select network. However, the hardware compatibility notes for the control units in this manual remain applicable unless stated otherwise.

## 1.1 Additional Documentation

This manual only covers the basic system installation necessary to result in a configurable system. IP Office applications and ancillary products, including IP telephones, are outside the range of this manual.

If those applications and products are to be part of the system installation, the separate documentation for those products should be obtained, read and understood prior to installation.

- **! IP Office Technical Bulletins**

You must obtain and read the IP Office Technical Bulletin relating to the IP Office software release which intend to install. The bulletin contains important information that may not have been included in this manual. IP Office Technical Bulletins are available from the [Avaya support](http://support.avaya.com) website (<http://support.avaya.com>).

### To download documentation:

1. Browse to <https://support.avaya.com>.
2. Select **Support by Product** and then **Documents**.
3. Enter **IP Office** in the **Enter Product Name** box and select the matching option from the displayed list.
4. Use the **Choose Release** drop-down to select the required IP Office release.
5. Select the type of documents required from the list and click **ENTER**.

## 1.2 Technical Specifications

The following is a summary of the technical specifications for the IP500 V2 control unit. For additional details for it and other units that can be attached, see [System Components](#)<sup>202</sup>.

Specification	Value																
Height	73mm (2U rack)																
Width	445mm																
Depth	365mm																
Maximum weight of chassis (fully loaded)	4kg maximum																
Operating Temperature	5°C to 40°C																
Operating Humidity	10% to 95% non-condensing																
Operation Altitude	2000m																
Storage Temperature	-40° C to 70°C																
AC voltage	100-240 V																
Frequency	50/60 Hz																
Maximum Amps	1.7A																
Storage Life	No limit on storage life.																
Service Life	At least 10 years, subject to operation conditions.																
Transport Management	No special requirements for transportation.																
Disposal Management	The IP500 V2 control unit does not contain expensive and toxic materials. Do not throw the device into unsorted municipal waste. Use designated utilization points for disposal of e-waste.																
<b>General</b>																	
Manufacturer Address	<b>Avaya LLC</b> 350 Mt. Kemble Avenue, Morristown, NJ 07960, USA																
Date of Manufacture	The Date of Manufacture is directly marked on the device label, composed of 12 alphanumeric characters in the format <i>yyLLwwdxxxxx</i> . The date and place of manufacture are defined as below.																
	<table border="1"> <thead> <tr> <th>Code Format</th> <th colspan="2">Year of Manufacture</th> <th colspan="2">Manufacturing Location</th> <th colspan="2">Calendar Week</th> <th>Day of Week</th> </tr> </thead> <tbody> <tr> <td>Digit Position</td> <td>1</td> <td>2</td> <td>3</td> <td>4</td> <td>5</td> <td>6</td> <td>7</td> </tr> </tbody> </table>	Code Format	Year of Manufacture		Manufacturing Location		Calendar Week		Day of Week	Digit Position	1	2	3	4	5	6	7
Code Format	Year of Manufacture		Manufacturing Location		Calendar Week		Day of Week										
Digit Position	1	2	3	4	5	6	7										

Specification	Value							
	Character	y	y	L	L	w	w	d
	Where LL =							
	<b>WZ</b>	Wistron Infocomm (Zhongshan) Corp 08 EAST KEJI RD HONGSHAN TORCH DEVELOPMENT ZONE HONGSHAN UANGDONG 528437 CHINA						
	<b>TL</b>	Wistron Corp SCIENCE-BASED INDUSTRIAL PARK HSIN ANN RD SINCHUO00 TAIWAN						

## 1.3 Equipment Availability

SAP codes and details of specific items within this documentation are for reference only. Items available in any specific locale should be confirmed against the local Avaya IP Office price list for that locale. The local price list may also include additional items relative to the installation requirements of that locale.

This documentation covers the equipment supported by IP Office 12.0. That includes equipment supported but no longer available as new from Avaya.

## 1.4 Repair

IP Office systems do not contain any user serviceable or repairable components. If a faulty unit is suspected, the whole unit should be replaced.

IP Office control units should not be opened under any circumstances except the [insertion of IP500 base cards](#)<sup>84</sup>.

## 1.5 RoHS

RoHS is a European Union directive for the Removal of Certain Hazardous Substances from Electrical and Electronic Equipment. Similar legislation has been or is being introduced in a number of other countries. Avaya has decided to make its global product range compliant with the requirements of RoHS.

The actions taken vary:

- In some cases equipment has been discontinued and is no longer available from Avaya.
- In some cases new manufactured stock has been made RoHS compliant and keeps its existing SAP code.
- In other cases the equipment has been replaced by a new RoHS compliant alternative with new SAP codes.
- The SAP codes within this document are for RoHS compliant equipment unless otherwise stated.

---

## 1.6 IP Office Modes

IP Office systems can run in a number of modes. For IP Office Release 12.0, the following modes are supported for IP500 V2 control units:

### IP Office Basic Edition Modes

The following operating modes are collectively referred to as IP Office Basic Edition mode. Its supports no IP based features apart from for system management and systems operate entirely standalone, they cannot be networked together.

- **IP Office Basic Edition**  
This is the default operating mode for control units.
- **IP Office Basic Edition - Norstar Mode**  
This mode operates the same as the IP Office Basic Edition mode. This mode is sold in Middle East and North African locales.
- **IP Office Basic Edition - PARTNER Mode**  
This mode operates the same as the IP Office Basic Edition mode. This mode is sold in North American locales.

### Standard Modes

Both the following modes can be used standalone or can be networked together to share resources and act (from the user perspective) as a single large system. This type of network is called an Small Community Network (SCN).

- **IP Office Essential Edition**  
Systems run in this mode if an **Essential Edition** license is added to the configuration. Systems set to this mode without a license will not support any telephony functions.
- **IP Office Preferred Edition**  
This mode is similar to IP Office Essential Edition but adds support for the Voicemail Pro and one-X Portal for IP Office applications. This mode is enabled by adding a **Preferred Edition (Voicemail Pro)** license to a system already licensed for **Essential Edition**.

### Other Modes

- **Server Edition**  
This IP Office mode is not covered by this documentation. It is centered around a Linux-based IP Office server that acts as the primary server for the network of any additional Server Edition servers that are then added. The IP Office expansion servers added to the network can be both Linux-based servers and IP500 V2 control units. Refer to the separate Server Edition documentation. The hardware compatibility notes for the IP500 V2 control unit in this manual remain applicable for Server Edition usage unless stated otherwise.
- **IP Office Select**  
This mode enables additional capacity and features for a Server Edition network. All systems in the network need to be configured as IP Office Select systems. Again, IP500 V2 control units can be employed as expansion systems in a IP Office Select network.
- **IP Office Subscription**  
This mode uses subscriptions (per-user per-month licenses) to enabled features. It is supported by systems running on IP500 V2 control units and on Linux-based servers including virtual servers. For details, refer to "[Deploying an IP500 V2A IP Office Subscription System](#)".

### 1.6.1 System SD Cards

IP500 V2 control unit must be fitted with an Avaya **System SD** card. The default mode of the system is determined by the type of System SD card present. The system can then be configured to the required mode.

The different System SD cards are:

- **IP Office U-Law SD Card**  
A system fitted with this type of card defaults to U-Law telephony and IP Office Basic Edition **Key System** operation. Intended for North American locales.
- **IP Office A-Law SD Card**  
A system fitted with this type of card defaults to A-Law telephony and IP Office Basic Edition **PBX System** operation. Intended for locales outside North America.

## 1.6.2 Overall Capacity

The following table is a summary only. Support for particular types of extension, trunk and user ports also depends on other factors such as local support variations. For example, BRI trunks are not supported in North American locales.

For more detailed capacity notes, refer to the "IP Office Platform Guidelines: Capacity" document.

		IP Office Basic Edition - PARTNER Mode	IP Office Basic Edition - Norstar Mode	IP Office Basic Edition	IP Office Essential Edition IP Office Preferred Edition IP Office Subscription
<b>Extensions</b>	Maximum Extensions	100 <sup>[1]</sup>	100 <sup>[1]</sup>	100 <sup>[1]</sup>	384
<b>Trunks</b>	Maximum Trunks	64	64	64	– <sup>[5]</sup>
	- Maximum Analog Trunks	32	32	32	204
	- Maximum BRI Channels <sup>[3]</sup>	–	12	12	32
	- Maximum PRI Channels <sup>[4]</sup>	24	30	30	240
	- Maximum SIP Channels <sup>[2]</sup>	20	20	20	– <sup>[5]</sup>
	- Maximum H323 IP Channels	–	–	–	– <sup>[5]</sup>

- 100 Extensions in 3-digit extension numbering mode. 48 extensions in 2-digit extension numbering mode.
  - For IP Office Basic Edition modes, the system assumes that the base control unit is always fully populated with up to 32 extensions, either real or phantom or a mix, to which it assigns extension numbers in sequence.
    - It does this before assigning extension numbers to any real extensions on attached external expansion modules up to the system extension limit. If the system extension limit has not been exceeded, any remaining extension numbers are assigned to additional phantom extensions.
- In all modes, voice compression hardware resources are also required for SIP support.
- IP Office Basic Edition mode systems do not support BRI and PRI trunks in the same system. They are also restricted to 12 BRI channels regardless of the BRI hardware installed.
- IP Office Basic Edition mode systems are limited to 1 x single-port PRI card.
- Capacity is dependent on licenses, voice compression resources and available bandwidth.

### 1.6.3 Hardware Support Summary

Note that even where indicated as supported, the availability and support of equipment may still be subject to local restrictions. For supported phones, see [IP Office Phones](#)<sup>39</sup>.

	IP Office Basic Modes	IP Office Essential Edition IP Office Preferred Edition	IP Office Subscription
<b>IP500 V2A Control Unit</b>	✓	✓	✓
<b>IP500 Base Cards</b>			
<b>IP500 DS8 Digital Station</b> <sup>[5]</sup>	✓ 3	✓ 3	✓ 3
<b>IP500 DS8A Digital Station</b>	✓ 4	✓ 4	✓ 4
<b>IP500 Analog Phone 2/8</b>	✓ 4	✓ 4	✓ 4
<b>IP500 VCM 32/64</b>	-	✓ 2	✓ 2
<b>IP500 4-Port Expansion</b>	-	✓ 1	✓ 1
<b>IP500 BRI Combo</b> <sup>[3]</sup>	✓ 2	✓ 2	✓ 2
<b>IP500 ATM Combo</b>	✓ 2	✓ 2	✓ 2
<b>IP500 ATM Combo V2</b>	✓ 2	✓ 2	✓ 2
<b>IP500 ETR6</b> <sup>[1]</sup>	✓ 3	-	-
<b>Unified Communications Module</b>	-	✓ 1	✓ 1
<b>Trunk Daughter Cards</b>			
<b>Analog Trunk Cards</b>	✓ 4	✓ 4	✓ 4
<b>BRI Trunk Cards</b> <sup>[3]</sup>	✓ 3	✓ 3	✓ 4
<b>PRI Trunk Cards</b> <sup>[3][4]</sup>	✓ 1	✓ 4	✓ 4
<b>Expansion Modules</b>			
<b>Number of Modules</b> <sup>[2]</sup>	8	12	12
<b>Digital Station</b>	✓	✓	✓
<b>Phone</b>	✓	✓	✓
<b>Analog Trunk</b>	✓	✓	✓
<b>Telephone Types</b> (see <a href="#">IP Office Phones</a> <sup>39</sup> for more details)			
<b>ETR Phones</b> (ETR ports)	✓	-	-
<b>DS Phones</b> (DS ports)	✓	✓	✓
<b>H323 IP Phones</b> (LAN)	-	✓	✓
<b>SIP IP Phones</b> (LAN)	-	✓	✓
<b>DECT R4</b> (LAN)	-	✓	✓
<b>Voicemail Types</b>			
<b>Embedded Voicemail</b>	✓	✓	✓
<b>Voicemail Pro</b>	-	✓	✓

- ETR6 is only supported in IP Office Basic Edition - PARTNER Mode and IP Office Basic Edition U-Law modes.
- External expansion modules can be added up to the overall limit for extensions and trunks. IP Office Basic Edition systems support only one Analog Trunk 16 module.
- IP Office Basic Edition mode systems do not support a mix of BRI and PRI trunks and only supports a maximum of 12 BRI channels.
- IP Office Basic Edition mode systems only support 1 single-port PRI card.
- DS8: Not supported in IP500 V2A. Use a DS8A instead.

## 1.6.4 Feature Support Summary

The table below is a general summary only. For more specific details refer to the installation documentation for the specific application.

		IP Office Basic Edition			IP Office Essential Edition	IP Office Preferred Edition	IP Office Subscription
		PARTNER Mode	Norstar Mode	Quick Mode			
Admin Applications	Phone Based Admin	✓	✓	✓	–	–	–
	IP Office Web Manager	✓	✓	✓	✓	✓	✓
	IP Office Manager	✓	✓	✓	✓	✓	✓
	Monitor (System Monitor)	✓	✓	✓	✓	✓	✓
	System Status Application	✓	✓	✓	✓	✓	✓
Applications	one-X Portal for IP Office	–	–	–	–	✓	✓
	SoftConsole	–	–	–	✓	✓	✓
	TAPI (1st Party)	–	–	–	✓	✓	✓
	TAPI (3rd Party)	–	–	–	✓	✓	✓
	Voicemail Pro	–	–	–	–	✓	✓
	Media Manager	–	–	–	–	✓	✓
Voicemail Languages	Embedded Voicemail	<ul style="list-style-type: none"> <li>Arabic, Cantonese, Danish, Dutch, English (UK), English (US), Finnish, French, French (Canada), German, Hebrew, Italian, Japanese, Korean, Mandarin, Norwegian, Polish, Portuguese, Portuguese (Brazil), Russian, Spanish, Spanish (Argentina), Spanish (Latin), Spanish (Mexico), Swedish, Turkish.</li> </ul>					
	Voicemail Pro	–	–	–	As above plus: Greek, Hungarian. Minus: Arabic, Spanish (Mexico).		

## 1.6.5 Supported Country Locales

When a new or defaulted system's configuration is first opened in IP Office Manager, the value set in the **Locale** field should always be checked and changed if necessary.

The system's locale sets factors such as the default ringing patterns and caller display settings. The locale also controls the language that a voicemail server will attempt to use for prompts by default.

Locale	IP Office Basic Edition			IP Office Essential Edition, IP Office Preferred Edition	IP Office Subscription
	Partner	Norstar	Quick		
Argentina	–	–	✓	✓	✓
Australia	–	–	✓	✓	–
Bahrain	–	✓	✓	✓	✓
Belgium	–	–	✓	✓	✓
Brazil	–	–	✓	✓	✓
Canada	✓	–	✓	✓	–
Chile	–	–	✓	✓	✓
China	–	–	✓	✓	✓
Colombia	–	–	✓	✓	✓
Czech	–	–	✓	✓	✓
Denmark	–	–	✓	✓	✓
Egypt	–	✓	✓	✓	✓
Finland	–	–	✓	✓	✓
France	–	–	✓	✓	–
Germany	–	–	✓	✓	✓
Greece	–	–	✓	✓	✓

Locale	IP Office Basic Edition			IP Office Essential Edition, IP Office Preferred Edition	IP Office Subscription
	Partner	Norstar	Quick		
Hong Kong	-	-	✓	✓	✓
Hungary	-	-	✓	✓	✓
Iceland	-	-	✓	✓	✓
India	-	-	✓	✓	✓
Ireland	-	-	✓	✓	-
Italy	-	-	✓	✓	✓
Japan	-	-	-	✓	✓
Korea	-	-	✓	✓	✓
Kuwait	-	✓	✓	✓	✓
Malaysia	-	-	✓	✓	✓
Mediterranean	-	-	-	✓	✓
Mexico	✓	-	✓	✓	✓
Morocco	-	✓	✓	✓	✓
Netherlands	-	-	✓	✓	-
New Zealand	-	-	✓	✓	✓
Norway	-	-	✓	✓	✓
Oman	-	✓	✓	✓	✓
Pakistan	-	✓	✓	✓	✓
Peru	-	-	✓	✓	✓
Philippines	-	-	✓	✓	✓
Poland	-	-	✓	✓	✓
Portugal	-	-	✓	✓	✓
Qatar	-	✓	✓	✓	✓
Russia	-	-	✓	✓	✓
Saudi Arabia	-	✓	✓	✓	✓
Singapore	-	-	✓	✓	✓
South Africa	-	✓	✓	✓	✓
Spain	-	-	✓	✓	✓
Sweden	-	-	✓	✓	✓
Switzerland	-	-	✓	✓	✓
Taiwan	-	-	✓	✓	✓
Turkey	-	✓	✓	✓	✓
United Arab Emirates	-	✓	✓	✓	✓
United Kingdom	-	-	✓	✓	-
United States	✓	-	✓	✓	-
Venezuela	-	-	✓	✓	✓

## 1.7 IP500 V2 System Components

The following are the typical components of a IP Office Essential Edition or IP Office Preferred Edition mode system based on an IP500 V2 control unit.

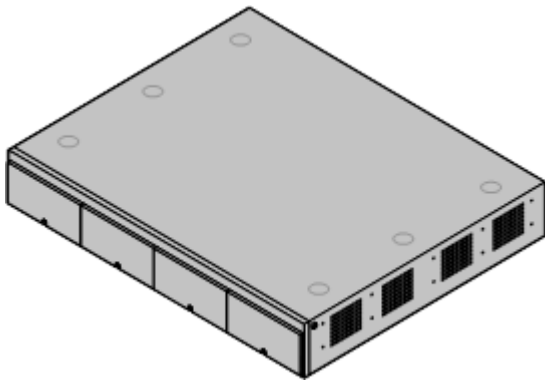

- [IP Office IP500 V2 System Unit](#)<sup>203</sup>  
The control unit holds the main configuration and performs the routing and switching for telephone calls and data traffic. Each control unit includes 4 slots for optional base cards to support trunk and phone extension ports.

-  [Avaya System SD Card](#)<sup>21</sup>  
This card holds the firmware and other files used by the system. An Avaya System SD card is mandatory for system operation.
  - The card's unique ID number is used for license validation.
  - The card also provides storage for Embedded Voicemail if used.

- [License Keys](#)<sup>269</sup>  
Various features and applications require licenses in the system's configuration. These are entered by uploading a single PLDS XML file containing all the system's license. The file and its licenses are specific to the ID number of the System SD card installed in the system.

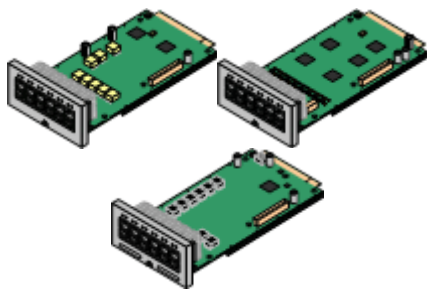

- [IP500 Base Cards](#)<sup>23</sup>  
The control unit has slots for up to 4 base cards, though specific cards may have other limits. These can be used to add ports for analog extensions, digital extensions, voice compression channels and other resources.

- [IP500 Digital Station Base Card](#)<sup>213</sup>
- [IP500 Analog Phone Base Card](#)<sup>210</sup>
- [IP500 VCM Base Card](#)<sup>215</sup>
- [IP500 4-Port Expansion Base Card](#)<sup>209</sup>

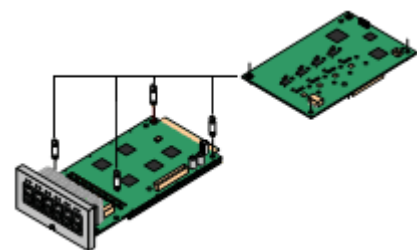

- [IP500 Trunk Daughter Cards](#)<sup>25</sup>  
Many of the base cards can be fitted with a daughter card in order to support various types of trunk connections.

- [IP500 Analog Trunk Card](#)<sup>218</sup>
- [IP500 Analog Trunk Card V2](#)<sup>218</sup>
- [IP500 BRI Trunk Card](#)<sup>219</sup>
- [IP500 PRI Trunk Card](#)<sup>220</sup>

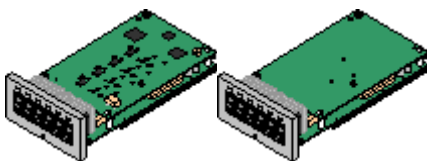

- [IP500 Combination Cards](#)<sup>23</sup>  
These card are pre-paired base and daughter cards. They provide 6 digital station ports, 2 analog phone ports, 10 voice compression channels and either 4 analog trunk ports or 4 BRI channels (2 ports). The trunk daughter card cannot be removed or replaced with another type.

- [IP500 BRI Combination Card](#)<sup>212</sup>
- [IP500 ATM Combination Card](#)<sup>211</sup>
- [IP500 ATM Combination Card V2](#)<sup>211</sup>

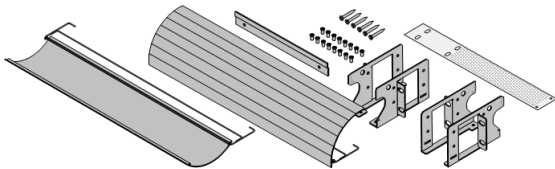
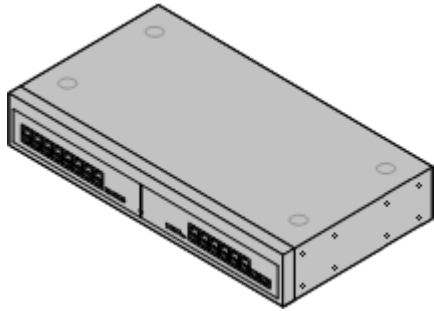

- **External Expansion Modules**<sup>26</sup>  
Additional ports can be added using a number of external expansion modules.
  - Systems support up to 8 external expansion modules as standard. If fitted with an IP500 4-Port Expansion Base Card, up to 12 external expansion modules are supported.
- **Power Supplies**<sup>30</sup>  
The IP500 control unit has an internal power supply unit. Each external expansion module is supplied with an external power supply unit. Additional power supply units may also be required for IP phones and some phone add-ons.
- **Power Cords**<sup>31</sup>  
Depending on the locale, different power cords need to be ordered for each control unit, external expansion module and any phones or devices using external power supply units.
- **Cables**<sup>33</sup>  
The system is designed primarily for connection to a structured cabling system using CAT3 UTP cabling. This approach allows telephone and data traffic to share the same wiring infrastructure and simplifies equipment moves.
- **Mounting Kits**<sup>37</sup>  
The control unit can be used free-standing, with external expansion modules stacked above it. With optional rack mounting kits, the control unit and external expansion modules can also be rack mounted. Alternatively with an optional wall mounting kit the IP500 control unit can be wall mounted. IP500 external expansion modules can also be wall mounted.
- **Surge Protectors and Barrier Boxes**<sup>36</sup>  
Where the installation includes extensions in other buildings additional protective equipment is required. This equipment may also be required in areas where the lightning risk is high.
- **Phones**<sup>39</sup>  
IP Office systems support a variety of Avaya digital and IP phones plus analog phones.
- **Application Software/DVDs**<sup>42</sup>  
The IP Office applications can be ordered on a number of DVDs. In addition they can be downloaded from the IP Office section of the [Avaya support](http://support.avaya.com) web site (<http://support.avaya.com>).

## 1.8 System SD Card



The IP Office system requires an [Avaya System SD card](#)<sup>206</sup> in order to operate. The card is inserted into the **System SD** slot on the rear of the control unit before the system is started.

- This card carries the firmware and various other files that the system loads when it powers up.
- The card's serial number is used to validate any licenses used by the system. Note that this means all system licenses are tied to the particular SD card and not to the control unit.
- The card's ID number is printed on the card's label after **PLDS ID**, **FK SN** or **FK** depending on the age of the card. On newer cards is a 12-digit number. Older cards may have a 10-digit number. For PLDS licensing, use the 12-digit number. On older cards, for licensing, prefix the 10-digit number with **11**.
- Once the system is operational, the card holds copies of various files such as the system configuration.
- If Embedded Voicemail is used to provide voicemail services rather than a separate Voicemail Pro server, then the System SD card stores all the voicemail prompts, messages, etc.

### Setting the System's Original Software Level

For a new IP Office control unit, the version of IP Office software that it loads from the system SD card when it is first powered up becomes its original software level. That value is written into the control unit's permanent memory and cannot be changed.

Therefore, it is important to ensure that the System SD card has been loaded with the correct version of software before the system is first powered up. This is done by using IP Office Manager to [load the required level of software onto the SD card](#)<sup>77</sup>.

---

## 1.9 Licensing

The IP Office system requires licenses for some features, see [Licenses](#)<sup>269</sup>. The license file can be either uploaded manually or [pre-loaded onto the System SD card](#)<sup>80</sup>.

### How is the system licensed?

- An XML file containing the full set of PLDS licenses is uploaded to the system. The license file is unique to the feature key serial number of the System SD card installed in the system.
- The card's ID number is printed on the card's label after **PLDS ID**, **FK SN** or **FK** depending on the age of the card. On newer cards is a 12-digit number. Older cards may have a 10-digit number. For PLDS licensing, use the 12-digit number. On older cards, for licensing, prefix the 10-digit number with **11**.

### Minimum License Requirements

For IP Office Essential Edition, the system requires an **Essential Edition** system license for the specific IP Office release you want it to run.

### Subscriptions

Systems can also obtain their entitlements for user and features through monthly subscriptions. For details refer to "[Deploying an IP500 V2A IP Office Subscription System](#)". Existing PLDS licensed systems can be migrated to subscription licensing.

## 1.10 Control Unit Cards

The following control unit cards are supported by IP Office R12.0 IP Office Essential Edition and IP Office Preferred Edition mode systems:

### 1.10.1 IP500 Base Cards

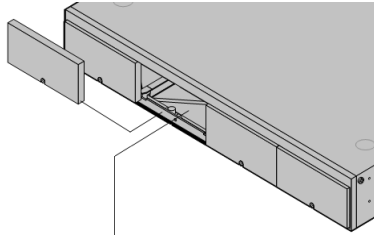

The IP500 V2 control unit has 4 slots for the insertion of IP500 base cards. The slots are numbered 1 to 4 from left to right. Normally they can be used in any order, however if the capacity for a particular type of card is exceeded, the card in the rightmost slot will be disabled.

Each base card includes an integral front panel with ports for cable connections. Typically the first 8 ports on the left are for connection of extension devices. The 4 ports on the left are used for connection of trunks if a [trunk daughter card](#)<sup>25</sup> is added to the base card.

#### [IP500 Digital Station Base Card](#)<sup>213</sup>

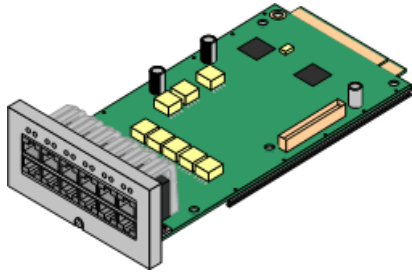

This card provides 8 DS (digital station) ports for the connection of Avaya digital phones (1400, 2400 and 9500 Series phones).

- **Maximum:**
  - **DS8:** 3 per control unit. Not supported by IP500 V2A control units.
  - **DS8A:** 4 per control unit.

#### [IP500 Analog Phone Base Card](#)<sup>210</sup>

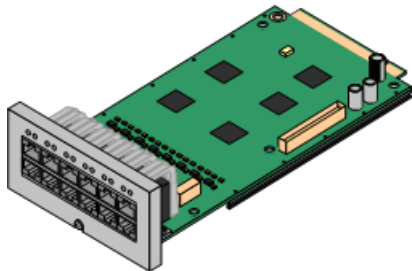

The card is available in two variants, supporting either 2 or 8 analog phone ports.

- **Maximum:** 4 per control unit.
  - The analog phone ports do not include a ringing capacitor. Where this is a requirement, connection should be via a Master socket containing ringing capacitors.
  - If fitted with an IP500 Analog Trunk daughter card, during power failure phone port 8 is connected to analog trunk port 12.

#### [IP500 VCM Base Card](#)<sup>215</sup>

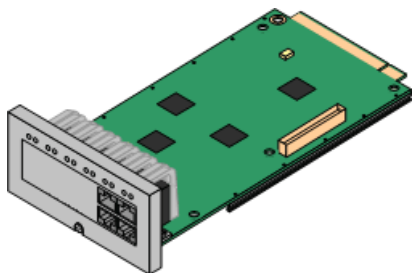

This card is available in variants supporting either 32 or 64 voice compression channels for use with VoIP calls.

- **Maximum:** 2 per control unit.
  - The VCM V2 and V3 cards are functionally the same. However, VCM V3 cards are only supported for R11.1.3 and higher.

#### [IP500 4-Port Expansion Base Card](#)<sup>209</sup>

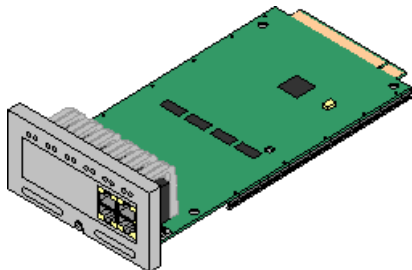

This card adds an additional 4 expansion ports for external expansion modules. The card is supplied with four 2m yellow interconnect cables.

- **Maximum:** 1 per control unit (Right-hand slot 4 only).
- This card does not accept a trunk daughter card.
- **Supported Expansion Modules:**

The 4-Port Expansion card supports the following external expansion modules:

  - IP500 Analogue Trunk Module.
  - IP500 BRI So Module.
  - IP500 Digital Station Module.
  - IP500 Digital Station Module A.
  - IP500 Digital Station Module B.
  - IP500 Phone Module.

#### [IP500 BRI Combination Card](#)<sup>212</sup>

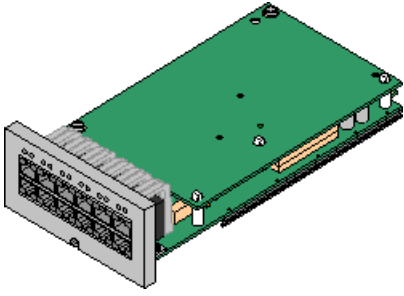

This card provides 6 digital station ports (1-6), 2 analog extension ports (7-8) and 2 BRI trunk ports (9-10, 4 channels). The card also includes 10 voice compression channels.

- **Maximum:** 2 per control unit.
- IP500 Combination cards are pre-fitted with a trunk daughter card which cannot be removed or changed for another type/capacity trunk daughter card.
- IP Office Basic Edition - Norstar Mode and IP Office Basic Edition systems are limited to a maximum of 12 BRI channels using BRI Combination and or BRI trunk daughter cards.

### [IP500 ATM Combination Card/IP500 ATM Combination Card V2](#)<sup>211</sup>

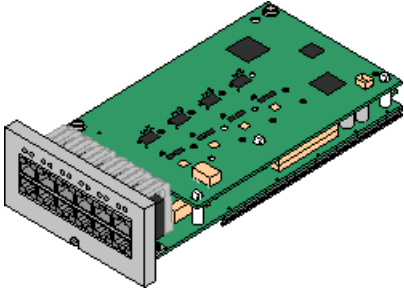

This card provides 6 digital station ports (1-6), 2 analog extension ports (7-8) and 4 analog trunk ports (9-12). The card also includes 10 voice compression channels.

- **Maximum:** 2 combination cards per control unit.
- IP500 Combination cards are pre-fitted with a trunk daughter card which cannot be removed or changed for another type/capacity trunk daughter card.
- The analog phone ports do not include a ringing capacitor. Where this is a requirement, connection should be via a Master socket containing ringing capacitors.
- During power failure phone port 8 is connected to analog trunk port 12.

### [Unified Communications Module](#)<sup>214</sup>

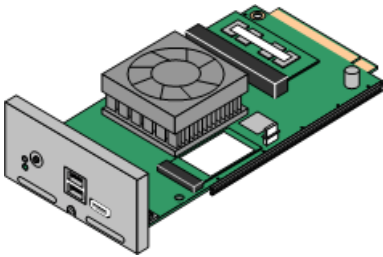

This card acts as an embedded Linux server for the Linux-based one-X Portal for IP Office and/or Voicemail Pro applications.

- **Maximum:** 1 per control unit.
- This card does not accept an IP500 trunk daughter card.

## 1.10.2 IP500 Trunk Cards

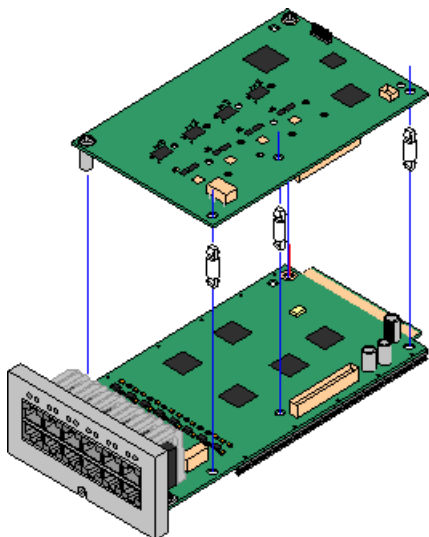

Many [IP500 base cards](#)<sup>23</sup> can be fitted with an IP500 trunk daughter cards to support the connection of trunks to the base card.

Each daughter card is supplied with the stand off pillars required for installation and a label to identify the daughter cards presence on the front of the base card after installation.

- IP500 Combination cards are pre-fitted with a trunk daughter card which cannot be removed or changed for another type of trunk daughter card.

### [IP500 Analog Trunk Card V2](#)<sup>218</sup>

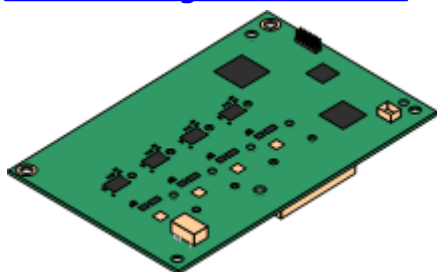

These cards allow the base card to support 4 analog loop-start trunks.

- **Maximum:** 4 per control unit.
  - The analog phone ports do not include a ringing capacitor. Where this is a requirement, connection should be via a Master socket containing ringing capacitors.
  - If fitted to a base card with analog phone ports, during power failure phone port 8 is connected to analog trunk port 12.

### [IP500 PRI-U Trunk Card](#)<sup>220</sup>

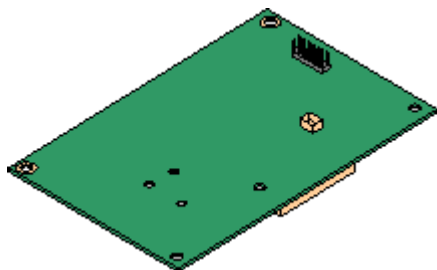

This type of card allows the base card to support PRI trunk connections. The cards are available in single and dual port variants. The card can be configured for E1 PRI, T1 robbed bit, T1 PRI or E1R2 PRI trunks.

- **Maximum:** 4 PRI port cards.
- The IP Office supports 8 unlicensed B-channels on each IP500 PRI-U port fitted. Additional B-channels, up to the capacity of ports installed and PRI mode selected require [IP500 Universal PRI \(Additional Channels\)](#)<sup>270</sup> licenses added to the configuration. These additional channels consume the licenses based on which additional channels are configured as in-service from port 9 of slot 1 upwards. D-channels are not affected by licensing.
- The PRI-U V2 cards are functionally the same as previous PRI cards, but only supported with IP Office R11.1 FP2 SP4 and higher.

### [IP500 BRI Trunk Card](#)<sup>219</sup>

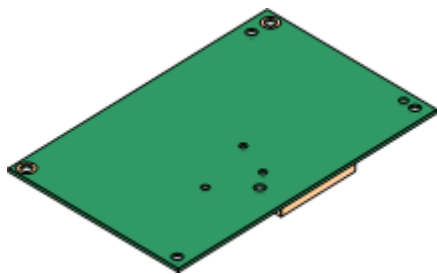

This card allows the base card to support up to 4 BRI trunk connections, each trunk providing 2B+D digital channels. The card is available in 2-port (4 channels) and 4-port (8 channels) variants.

- **Maximum:** 4 per control unit.
- **S-Bus Connection:** The card can be switched from To trunk mode to So mode. This mode requires additional terminating resistors and an ISDN crossover cable connection, see [BRI Port \(So\)](#)<sup>260</sup>.

## 1.11 External Expansion Modules

These modules can be used to add additional ports to an IP Office systems. The number of external expansion modules supported depends on the control unit type. Each module uses an external [power supply unit](#)<sup>30</sup> supplied with the module. A locale specific [power cord](#)<sup>31</sup> for the PSU must be ordered separately.

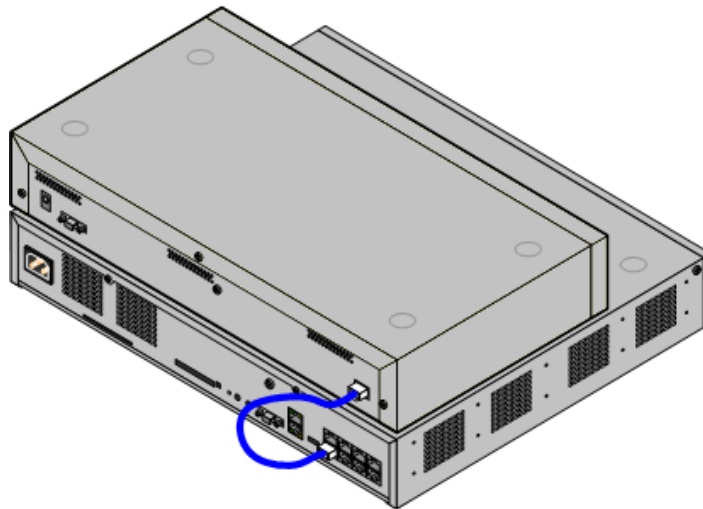

IP500 System with External Expansion Module

- Systems support up to 8 external expansion modules as standard. If fitted with an IP500 4-Port Expansion Base Card, up to 12 external expansion modules are supported.
  - Each external expansion module is supplied with a blue 1 meter (3'3") expansion interconnect cable. This cable must be used when connecting to expansion ports on the rear of a control unit.
  - When connecting to expansion ports on an IP500 4-Port Expansion card, a supplied yellow 2 meter (6'6") expansion interconnect cable can be used in place of the supplied blue cable. 4 Yellow cables are supplied with the IP500 4-Port Expansion card.

- **! Important: External Expansion Module Power**

In order to be detected and operated correctly, external expansion modules must start before the IP Office control unit. Normally this achieved by connected all expansion modules to the same power strip as the control unit. The control unit applies a short delay to its own start-up process to ensure that expansion modules powered on at the same time as it are detected.

### IP500 External Expansion Modules

Expansion modules include an external power supply unit (PSU) and a 1m blue interconnect cable. They do not include a locale specific power cord for the external PSU or any phone extension cables.

Variant	Country	SAP Code
<b>Digital Phones (Non-IP)</b>		
<a href="#">IPO 500 Digital Station 16B</a> <sup>226</sup>	All	700501585
<a href="#">IPO 500 Digital Station 30B</a> <sup>226</sup>	All	700501586
<b>Analog Phones</b>		
<a href="#">IPO 500 Phone 16</a> <sup>228</sup>	All	700449507
<a href="#">IPO 500 Phone 30</a> <sup>228</sup>	All	700426224
<b>Others</b>		
<a href="#">IPO 500 Analog Trunk 16</a> <sup>223</sup>	US	700449473

### 1.11.1 IP500 External Expansion Modules

The following IP500 external expansion modules are supported by IP Office Release 12.0. Each module uses an external [power supply unit](#)<sup>30</sup> supplied with the module. A locale specific [power cord](#)<sup>31</sup> for the PSU must be ordered separately.

The external module can be stacked on top of the control unit. They can also be wall or rack mounted using one of the [IP Office mounting kits](#)<sup>237</sup>.

- Systems support up to 8 external expansion modules as standard. If fitted with an IP500 4-Port Expansion Base Card, up to 12 external expansion modules are supported.

#### [IP500 Digital Station B/B2 Modules](#)<sup>226</sup>

Provides an additional 16 or 30 RJ45 ports. These can be used as either [DS](#)<sup>262</sup> ports or BST ports. However, the module can only support one port type at any time. For IP Office Release 10.1 the DS16B/DS30B modules have been superseded by the DS16B2/DS30B2 models.

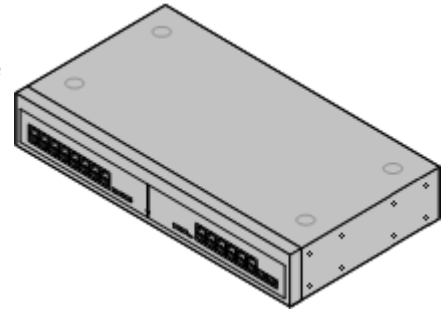

#### [IP500 Phone Modules](#)<sup>228</sup>

Provides, depending on variant, an additional 16 or 30 [PHONE](#)<sup>266</sup> ports for connecting analog phones.

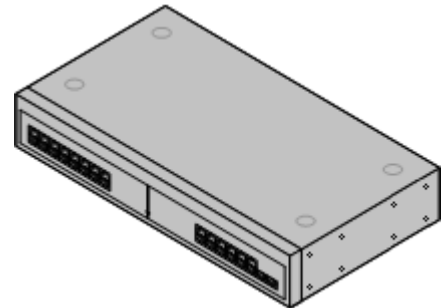

#### [IP500 Analog Trunk Module](#)<sup>223</sup>

Provides an additional 16 [ANALOG](#)<sup>269</sup> ports for connection of analog trunks. Supports both loop-start and ground-start trunks.

- Use with ground start trunks requires that the trunk module and the IP Office control unit are grounded.

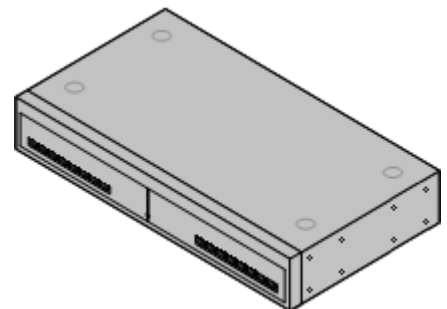

## 1.11.2 IP400 External Expansion Modules

The following IP400 external expansion modules are supported by IP Office Release 12.0 and can be used with IP500 V2 control units.

Each module uses an external [power supply unit](#)<sup>30</sup> supplied with the module. A locale specific [power cord](#)<sup>31</sup> for the PSU must be ordered separately.

### [IP400 Analog Trunk Module \(ATM16\)](#)<sup>231</sup>

Provides an additional 16 [ANALOG](#)<sup>259</sup> ports for connection of analog trunks. Supports both loop-start and ground-start trunks.

- Available in a number of variants for different locales.
- Use with ground start trunks requires that the trunk module and the IP Office control unit are grounded.

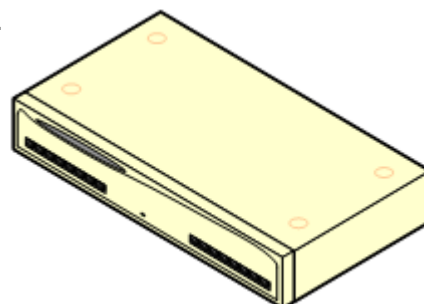

### [IP400 Digital Station Module V2](#)<sup>233</sup>

Provides, depending on variant, an additional 16 or 30 [DS](#)<sup>262</sup> ports for supported [Avaya digital phones](#)<sup>39</sup>. Supersedes the previous Digital Station module.

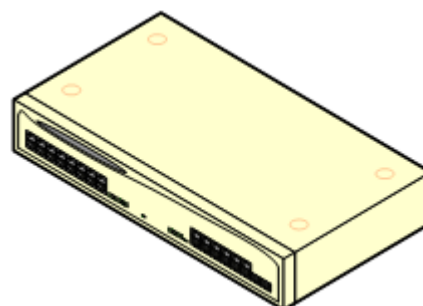

### [IP400 Phone Module V2](#)<sup>235</sup>

Provides, depending on variant, an additional 16 or 30 [PHONE](#)<sup>266</sup> ports for analog phones. Supersedes the previous Phone module. With IP Office 3.1, the Phone V2 supports a wider range of message waiting indication (MWI) options than Phone V1 modules.

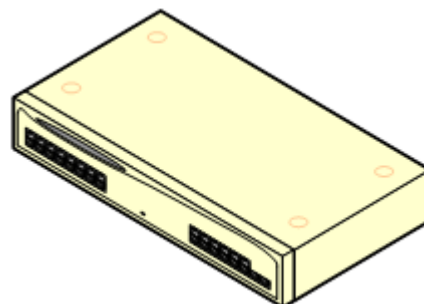

### 1.11.3 Connecting External Expansion Modules

The integral expansion ports on a control unit are located on the rear of the unit. An additional 4 expansion ports can be added to the front of the control unit by installing an IP500 4-Port Expansion card.

- Each external expansion module is supplied with a blue 1 meter (3'3") expansion interconnect cable. This cable must be used when connecting to expansion ports on the rear of a control unit.
- When connecting to expansion ports on an IP500 4-Port Expansion card, a supplied yellow 2 meter (6'6") expansion interconnect cable can be used in place of the supplied blue cable. 4 Yellow cables are supplied with the IP500 4-Port Expansion card.

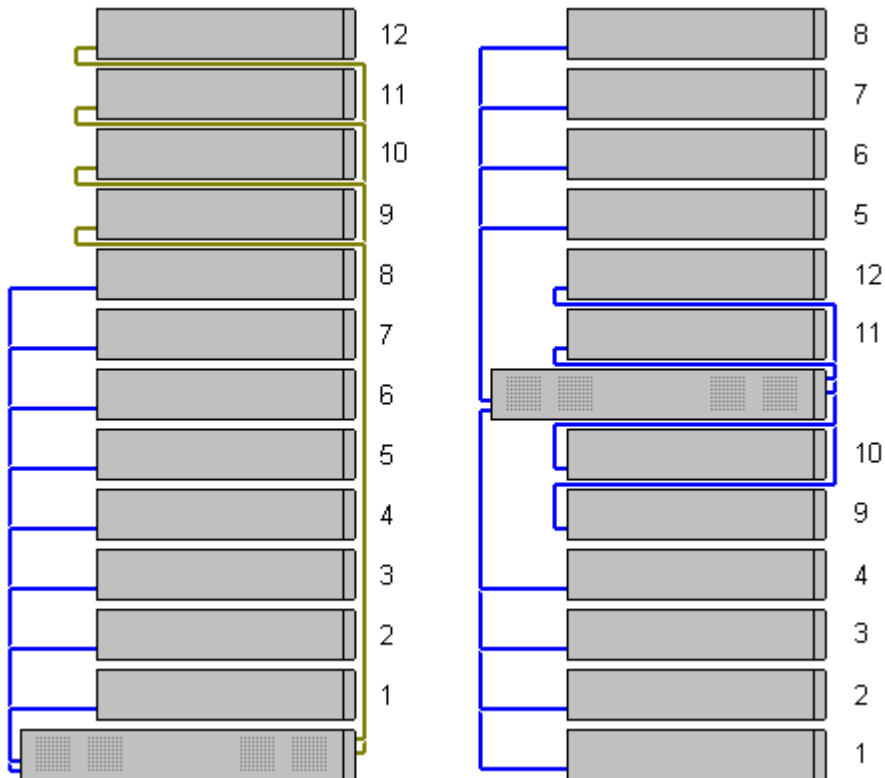

• **Supported Expansion Modules:**

The 4-Portal Expansion card supports the following external expansion modules:

- IP500 Analogue Trunk Module.
- IP500 BRI So Module.
- IP500 Digital Station Module.
- IP500 Digital Station Module A.
- IP500 Digital Station Module B.
- IP500 Phone Module.

---

## 1.12 Power Supplies and Cables

All IP Office control units and external expansion modules either have an internal power supply unit or are supplied with an external power supply unit.

### 1.12.1 Power Supplies

IP500 V2 control units have an internal power supply unit and so only require a suitable [locale specific power cord](#)<sup>31</sup> and a power outlet that includes a switch. Note that if the power cord includes an earth lead, the power outlet must be connected to a protective earth.

External expansion modules are all supplied with an external power supply unit (PSU). These PSUs include an integral 1.5 meter lead for connection to the control unit or expansion module. A [power cord](#)<sup>31</sup> for connection from the PSU to the power outlet is not included as this varies by locale. The appropriate power cord must be ordered separately or sourced locally.

- The connector required on the power cord is an IEC60320 C13 connector.

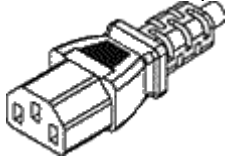

- **! Important: External Expansion Module Power**

In order to be detected and operated correctly, external expansion modules must start before the IP Office control unit. Normally this is achieved by connecting all expansion modules to the same power strip as the control unit. The control unit applies a short delay to its own start-up process to ensure that expansion modules are powered on at the same time as it is detected.

- Additional power supply units are required for phone button modules and may also be required for Avaya IP phones.
- Avaya IP phones can use IEEE 802.3af Power over Ethernet (PoE) power supplies.



## 1.12.2 Power Supply Cords

Each control unit and expansion module requires a switched power outlet socket rated at 110-240V ac, 50-60Hz. Connection from that power outlet socket requires an appropriate locale specific power cord which is not supplied with the unit and must be ordered separately. Note that if the power cord includes an earth lead, the power outlet must be connected to a protective earth.

Power cords must not be attached to the building surface or run through walls, ceilings, floors and similar openings. Installation measures must be taken to prevent physical damage to the power supply cord, including proper routing of the power supply cord and provision of a socket outlet near the fixed equipment or positioning of the equipment near a socket outlet.

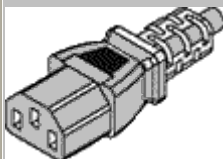
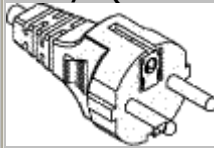
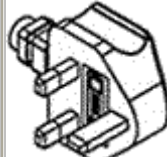
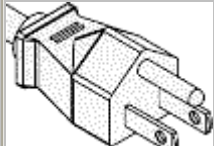
For locales not detailed below an appropriate power cord must be obtained locally.

Power Cord Type	Power Outlet Plug Type	Locales	SAP Codes
<b>Earthed Power Cords (IEC60320 C13)</b> 	<b>CEE7/7 (Schuko)</b> 	Europe and South Africa.	700289762
	<b>BS1363</b> 	Czech Republic, Ireland, United Kingdom.	700289747
	<b>NEMA5-15P / CS22.2 No.42</b> 	North, Central and South America.	700289770

-  **Caution:**  
 Connect the AC power supply only to the designated power port marked on the product, ensuring that the switched AC power socket used is near the equipment and easily accessible.
-  **Danger:**  
 Never alter the AC cord or plug. If the plug does not fit into the outlet, have a proper outlet installed by a qualified electrician. Improper connection increases the risk of electric shock.

---

### 1.12.3 Power Supply Backup

The use of an Uninterrupted Power Supply (UPS) with any telephone system is strongly recommended. Even at sites that rarely lose electrical power, that power may occasionally have to be switched off for maintenance of other equipment. In addition, most UPSs also provide an element of power conditioning, reducing spikes and surges.

The capacity of UPS systems and the total equipment load the UPS is expected to support are usually quoted in VA. Where equipment load is quoted in Watts, multiply by 1.4 to get the VA load.

The calculation of how much UPS capacity is required depends on several choices.

- **What equipment to place on the UPS?**

Remember to include server PCs such as the voicemail. It is recommended that the total load on a new UPS is never greater than 75% capacity, thus allowing for future equipment.

- **How many minutes of UPS support is required?**

Actual UPS runtime is variable, it depends on what percentage of the UPS capacity the total equipment load represents. For example, a 1000VA capacity UPS may only support a 1000VA (100%) load for 5 minutes. This relationship is not linear, the same UPS may support a 500VA (50%) load for 16 minutes. Therefore, the lower the percentage of maximum capacity used, the increasingly longer the UPS runtime, for example up to 8 hours.

- **How frequent are the power losses?**

You also need to include allowance for the UPS recharge time. For most UPS's the ratio of discharge to full recharge time is 1:10.

- **How many output sockets does the UPS provide?**

Multiple UPS units may be required to ensure that every item of supported equipment has its own supply socket.

#### Example Values

The dominate factor in the power consumption of an IP Office system is the telephones attached to the control unit and any external expansion modules. This does not include IP telephones which require their own separate power supplies. If any server PCs are being used by the system, the requirements of those PCs should also be included in the assessment. Similarly support for adjunct systems such as DECT should be considered.

The following are worst case figures tested found using fully populated control units and external expansion modules:

- **IP500 V2 Control Unit:** 115W.
- **IP500 Digital Station 16 External Expansion Module:** 31W.
- **IP500 Digital Station 30 External Expansion Module:** 56W.
- **IP500 DS16A Digital Station RJ21 External Expansion Module:** 34W.
- **IP500 DS30A Digital Station RJ21 External Expansion Module:** 60W.
- **IP500 Phone 16 External Expansion Module:** 25W.
- **IP500 Phone 30 External Expansion Module:** 45W.
- **IP500 Analog Trunk Module 16 External Expansion Module:** 8.8W.

## 1.12.4 Cabling and Cables

The IP Office systems are designed primarily for use within an RJ45 structured cabling system using CAT3 unshielded twisted-pair (UTP) cabling and RJ45 sockets.

A structured cabling system is one where cables are run from a central RJ45 patch panel in the communications/data room to individual RJ45 sockets at user locations. All wires in each cable between the patch panel and the desk socket are connected straight through. This arrangement allows devices connected at the patch panel to be swapped to match the type of device that needs to be connected at the user socket. For example, making one user socket a phone port and another user socket a computer LAN port, without requiring any rewiring of the cables between the patch panel and the user location.

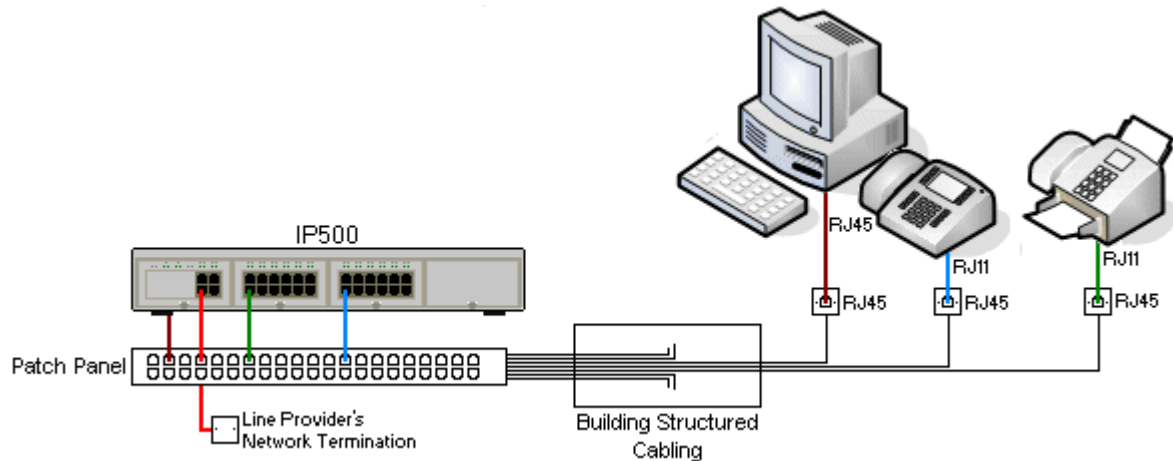

- **Traditional IDC Punchdown Wiring Installations**

Where necessary, the far end RJ45 plug can be stripped from IP Office cables and wired into traditional wiring systems using punch-block connectors. This type of installation should be performed by an experienced wiring technician.

- **Trunk Connections**

The majority of IP Office trunk ports use RJ45 connectors for acceptance of an RJ45-to-RJ45 cable. However, connection at the line provider's end may require use of a different plug type in order to match the line providers equipment.

- **RJ11 Phone Connectors**

Many phones use RJ11 sockets and are supplied with RJ11-to-RJ11 cables. RJ11 plugs can be inserted into RJ45 sockets and in many case the connection will work. However this is not recommended or supported as the connection lock is not truly positive and may become disconnected. An [RJ45-to-RJ11 cable](#)<sup>262</sup> is available for these connections.

## Avaya IP Office Cables

The following are Avaya supplied cables available for use with IP Office systems. The maximum length is applicable if the standard Avaya cable is replaced (if allowed) with an alternate non-Avaya cable.

Cable	Description	SAP Code	Standard Length	Maximum Length
<a href="#">9-Way DTE Cable</a> <sup>268</sup>	Connects to control unit RS232 DTE port. 9-Way D-type plug to 9-way D-type socket.	-	2m/6'6".	2m/6'6".
<a href="#">Structured Cabling DS Line Cable</a> <sup>262</sup>	Connects from RJ45 sockets to RJ11 socketed DS and analog phones.	TT700047871	4m/13'2".	See table below.
<a href="#">BRI/PRI Trunk Cable</a> <sup>261</sup>	Connects BRI/PRI trunk ports to the line provider's network termination point. RJ45 to RJ45. Red.	700213440	3m/9'10".	-
<a href="#">Expansion Interconnect Cable</a> <sup>263</sup>	Connects the control unit to expansion modules. RJ45 to RJ45. Blue. May be replaced by a yellow interconnect cable (2m (6'6") - 700472871) supplied with the <a href="#">IP500 4-Port Expansion</a> <sup>209</sup> card when using that card.	700213457	1m/3'3".	1m/3'3".
<a href="#">LAN Cable</a> <sup>264</sup>	Connects from IP Office LAN ports to IP devices. RJ45 to RJ45. Grey.	700213481	3m/9'10".	100m/328'.

The table below details the maximum total cable distances for non-IP extensions using different cable thicknesses. Cabling should be Category-1 unshielded twisted pair cable or better.

Telephone	Unshielded Twisted-Pair (UTP) - 50nf/Km		
	AWG22 (0.65mm)	AWG24 (0.5mm)	AWG26 (0.4mm)
1400 Series	1200m/3937'	1000m/3280'.	670m/2200'
9500 Series	1200m/3937'	1000m/3280'	670m/2200'
Analog Phones	1000m/3280'	1000m/ 3280'	400m/1312'

## 1.12.5 Grounding



All IP Office control units and external expansion modules must be connected to a functional ground. Where the unit is connected to a power outlet using a power cord with an earth lead, the power outlet must be connected to a protective earth.

Use of ground connections reduces the likelihood of problems in most telephony and data systems. This is especially important in buildings where multiple items of equipment are interconnected using long cable runs, for example phone and data networks.

In some cases, such as ground start trunks, in addition to being a protective measure, this is a functional requirement for the equipment to operate. In other cases it may be a locale regulatory requirement and or a necessary protective step, for example areas of high lightning risk.

-  **WARNING**

During installation do not assume that ground points are correctly connected to ground. Test ground points before relying on them to ground connected equipment.

The ground point on IP Office control units and external expansion modules are marked with a  or  symbol. Ground connections to these points should use a 14 AWG solid wire with either a green sleeve for a functional ground or green and yellow sleeve for a protective ground.

- **Additional protective equipment**

In addition to grounding, additional protective equipment will be required in the following situations. Refer to "[Out of Building Telephone Installations](#)<sup>36</sup>".

- On any Digital Station or Phones external expansion module connected to an extension located in another building.
- In the Republic of South Africa, on all Analog Trunk external expansion modules (ATM16) and on any control units containing an analog trunk cards (ATM4/ATM4U).

## 1.12.6 Lightning Protection/Out-of-Building Connections

The following are the only supported scenarios in which wired extensions and devices outside the main building can be connected to the IP Office system. In these scenarios, additional protection, in the form of protective grounding and surge protectors, must be fitted.

- ⚠ WARNING**

The fitting of additional protection does not remove the risk of damage. It merely reduces the chances of damage.

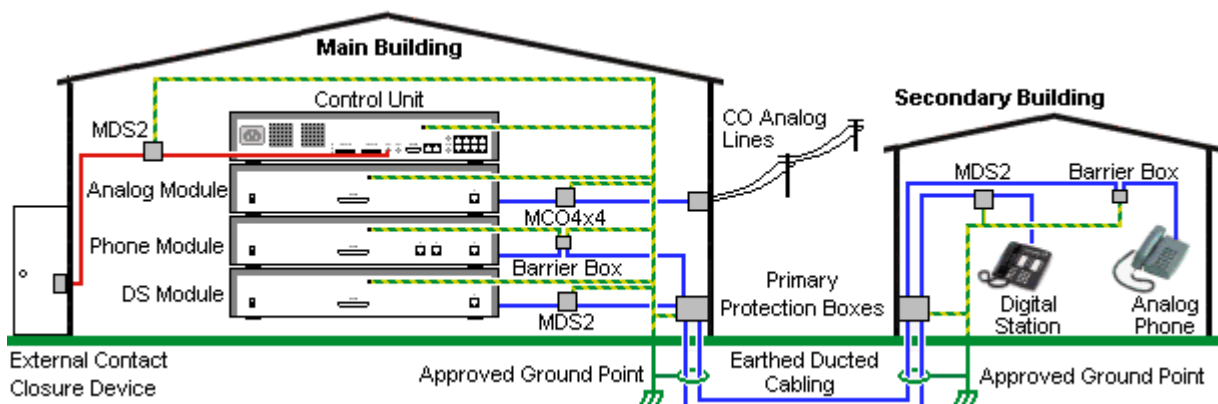

- Only ports on IP Office external expansion modules are supported. Out-of-building connection to ports on base cards in the control unit is not supported.
- Cables of different types, for example trunk lines, phone extensions, ground and power connections, should be kept separate.
- All cabling between buildings should be enclosed in grounded ducting. Ideally this ducting should be buried.
- A Primary Protection Box must be provided at the point where the cables enter the building. This should be three point protection (tip, ring and ground). Typically this would be gas tube protection provided by the local telephone company. The ground wire must be thick enough to handle all the lines being affected by indirect strike at the same time.

Connection Type	Protection Device Type	Requirement
<b>Analog Phone Extensions</b> Phones External expansion module (POT <sup>186</sup> or PHONE <sup>266</sup> ) ports only.	<b>IP Office Barrier Box</b> <sup>186</sup> Supports a single connection. Maximum of 16 on any expansion module.	<ul style="list-style-type: none"> <li>• Connection from the external expansion module to the phone must be via a surge protector at each end and via the primary protection point in each building.</li> <li>• The IP Office external expansion modules, control unit and IROB devices must be connected to the protective ground point in their building.</li> </ul>
<b>DS Phone Extensions</b>	<b>ITW Linx MDS2</b> <sup>185</sup> Supports up to 4 connections. This device was previously referred to as the Avaya 146E.	<ul style="list-style-type: none"> <li>• The between building connection must be via earthed ducting, preferable underground. The cable must not be exposed externally at any point.</li> </ul>
<b>Analog Trunks</b>	<b>ITW Linx MCO4x4</b> <sup>185</sup> Supports up to 4 two-wire lines. This device was previously referred to as the Avaya 146C.	<p>For installations in the Republic of South Africa, the fitting of surge protection on analog trunks is a requirement.</p> <p>For other locations where the risk of lightning strikes is felt to be high, additional protection of incoming analog trunks is recommended.</p>
<b>External Output Switch</b>	<b>ITW Linx MDS2</b> <sup>185</sup> Supports up to 4 connections. This device was previously referred to as the Avaya 146E.	<p>Connections from an IP Office Ext O/P port to an external relay device must be via a surge protector.</p> <p>When using the MDS2 on the Ext O/P port, use only the Line 1 and Equipment 1 jacks, do not use the Line 2 or Equipment 2 jacks.</p>

The towerMAX range of devices are supplied by ITWLinx (<http://www.itwlinx.com>).

## 1.13 Wall and Rack Mounting

All the IP Office control units are designed to be free-standing. On systems with external expansion modules, the control unit and modules are intended to be stacked.

Using additional option mounting kits, some systems can be wall or rack mounted.

Control/Expansion Unit	Wall Mount	Rack Mount
IP500 V2 Control Unit	✓	✓
IP500 External Expansion Modules	✓	✓

### 1.13.1 Wall Mounting Kits

IP500 V2 control units and IP500 external expansion modules can be wall or rack mounted. To do this, a wall mounting kit is required in addition to suitable wall fixings.

In addition to the existing [environmental requirements](#)<sup>51</sup> for an IP Office system, the following additional requirements apply when wall mounting a unit:

- The wall surface must be vertical, flat and vibration free. Attachment to temporary walls is not supported.
- Only the screws provided with the mounting kit should be used to attach the brackets to the control unit or expansion modules.
- The installation must be done by a service person.
- Ensure that the system has been shut down and power has been removed from all the units. Shut down the system using a shutdown command and then remove the power. Do not simply remove the power.
- A suitable plywood mounting surface of at least 1m x 1m x 19mm (39" x 39" x 0.75") is required. If an expansion box is being mounted as well a plywood mounting surface of at least 1.2m x 1.2m x 19mm (48" x 48" x 0.75") is required.
- A minimum of 6 x 45mm long 5mm/6mm ( 1.75" #10/#12) pan head screws must be used to secure the plywood to the wall studs.
- The supplied 20mm long 4mm (#8 3/4") wood screws must be used to secure the brackets to the plywood mounting surface

The following kit is currently available:

- **IPO IP500 WALL MNTG KIT V3** (SAP Code 700503160)

This kit can be used for [wall and rack mounting](#) of IP500 V2 control units and IP500 external expansion modules. The kit incorporates cable routing at the front and rear of the unit. For wall mounted control units, it allows orientation of the control unit base card slots to the left or to the right.

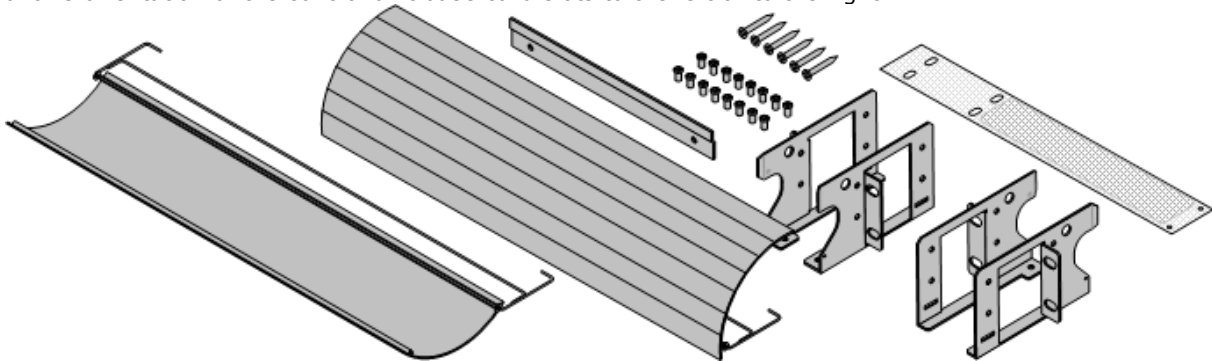

## 1.13.2 Rack Mounting Kits

All IP Office control units and external expansion modules can be rack mounted into standard 19" rack systems. Each unit requires a 2U slot space within the rack. Rack mounting requires a kit for each control unit and external expansion module.

Where systems are being rack mounted, the effect of conditions within the rack cabinet must be considered. For example, the rack temperature may be above the room temperature and airflow within the rack is restricted. The [environmental requirements](#)<sup>51</sup> for the individual IP Office units are still applicable inside the rack cabinet.

- **IPO IP500 WALL MNTG KIT V3** (SAP Code 700503160)

This kit can be used for [wall and rack mounting](#) of IP500 V2 control units and IP500 external expansion modules. The kit incorporates cable routing at the front and rear of the unit. For wall mounted control units, it allows orientation of the control unit base card slots to the left or to the right.

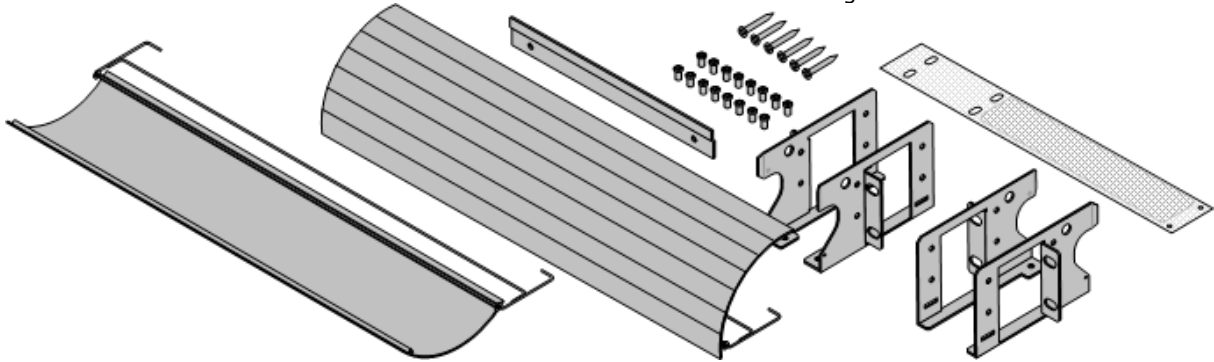

- **IPO IP500 RACK MNTG KIT** (SAP Code 700429202)

This kit contains all the components required for the rack mounting of a single IP500 V2 control unit or IP500 external expansion module. This includes screws for fixing of the brackets to the module, bolts for securing the module in the rack and cable tidy brackets..

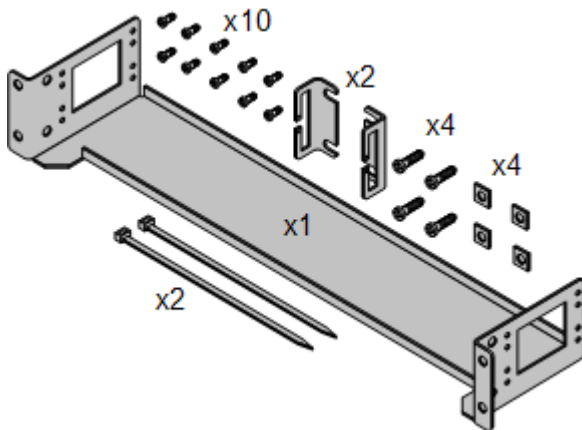

### Barrier Box Rack Mounting Kit

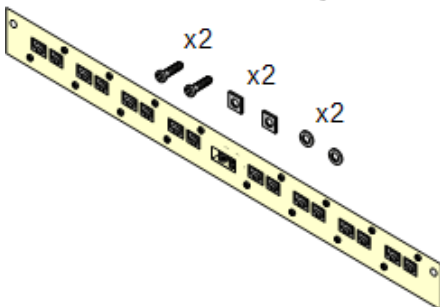

- **Barrier Box Rack Mounting Kit** (SAP 700293905)

Barrier boxes must be used for [out-of-building analog phone extensions](#)<sup>36</sup>. This bracket allows up to 8 IP Office barrier boxes to be rack mounted and simplifies the number of connections to the protective ground point in the rack. This kit must be used when more than 3 barrier boxes are in use and supports a maximum of 16 barrier boxes for a single external expansion module.

## 1.14 IP Office Phones

IP Office Release 12.0 supports the following phones and phone add-ons. Availability may depend on location and may be subject to local restrictions. For historic phone support, see [Hardware/Software Compatibility](#)<sup>260</sup>. For details of button modules, see [Phone Button Modules](#)<sup>240</sup>.

- Note that support

### Avaya DS Digital Telephones (DS Ports)

These digital stations connect to the system via [DS](#)<sup>262</sup> ports.

- **1400 Series:** 1403, 1408, 1416
- **9500 Series:** 9504, 9508

The following additional DS port phones are only supported in IP Office Essential Edition and IP Office Preferred Edition modes:

- **2400 Series:** 2402, 2410, 2420.

### Analog Telephones

Analog phones and devices connect to the system via [PHONE](#)<sup>266</sup>. Due to the variety of analog phones and devices available, no guarantee of operation is given. It is the responsibility of the installer/maintainer to test and verify the operation of proposed analog equipment.

- **6200 Series:** 6211, 6219, 6221 (*North America*).
- **B100 Series:** B149, B159, B169\*.
- **Interquartz Gemini:** 9330-AV, 9335-AV, 9281-AV (*Europe, Middle East, Africa, Asia-Pacific*).

### IP Telephones

IP Phones (SIP and H323) connect to the system via the RJ45 LAN or WAN. These device require an Avaya IP Endpoint license and voice compression resources from the system (see [Voice Compression Channels](#)<sup>41</sup>).

#### H323:

- **1600 Series:** 1603IP/SW, 1608, 1608-I, 1616, 1616-I
- **3700 Series:** 3720, 3725, 3730, 3735, 3745, 3749, 3755, 3759 - Connection via DECT R4 base stations.
- **9600 Series:** 9608, 9608G, 9611G, 9621G, 9641G, 9641GS.

#### SIP:

- **1000 Series:** 1010, 1040
- **1100 Series:** 1120E, 1140E
- **1200 Series:** 1220, 1230
- **B100 Series:** B169\*, B179, B199. (\*The B169 is a DECT phone that connects to a DECT base station. The base station connects to the IP Office via either an analog and SIP base station.)
- **D100 Series:** These DECT handsets (up to 8) use a base station that connects to the IP Office system using a SIP trunk and appear on the IP Office as SIP extensions.
- **H175:** SIP video telephone.
- **H200 Series:** H229, H239, H249.
- **J100 Series:** J129, J139, J159, J169, J179, J189.
- **K100 Series:** K155, K165, K175 including K155 V3 and K175 V3 models.

### Softphone Clients

The following softphone clients are supported with IP Office Essential Edition:

- **Avaya Workplace Client.**
- **IP Office User Portal**

### Other Phones

Whilst non-Avaya analog and IP phones may operate with the system, Avaya will not provide support for those phones. The same also applies to other Avaya phones not specifically supported.

---

## 1.15 VoIP/IP Telephony

IP Office is a converged telephony system. That is, it combines aspects of traditional PABX telephone systems and digital IP data and telephony systems.

The VoIP mode of operation can include external SIP trunks, IP trunks between customer systems and/or H.323 or SIP IP telephones for users. In either case the following factors must be considered:

- The IP Office control unit must be fitted with [voice compression channels](#)<sup>41</sup>. These are used whenever an IP device (trunk or extension) needs to communicate with a non-IP device (trunk or extension) or to a device that uses a different codec.
- A network assessment is a mandatory requirement for all systems using VoIP. For support issues with VoIP, Avaya may request access to the network assessment results and may refuse support if those are not available or satisfactory.

A network assessment would include a determination of the following:

- A network audit to review existing equipment and evaluate its capabilities, including its ability to meet both current and planned voice and data needs.
- A determination of network objectives, including the dominant traffic type, choice of technologies, and setting voice quality objectives.
- The assessment should leave you confident that the implemented network will have the capacity for the foreseen data and voice traffic, and can support H.323, DHCP, TFTP and jitter buffers in H.323 applications.
- An outline of the expected network assessment targets is:

Test	Minimum Assessment Target
Latency	Less than 150ms.
Packet Loss	Less than 3%.
Duration	Monitor statistics once every minute for a full week.

## 1.15.1 Voice Compression Channels

Calls to and from IP devices require conversion to the audio codec format being used by the IP device. For IP Office systems, that conversion is done by voice compression channels as detailed in the table below.

For IP500 V2 control units, channels can be added using [IP500 VCM cards](#)<sup>215</sup> and [IP500 Combination Cards](#)<sup>211</sup>. These support the common IP audio codecs: G.722, G.711, G.723, G.729a and G.729b. Note: G.729b is not supported on Linux-based IP Office systems.

The voice compression channels are used as follows:

Call Type	Voice Compression Channel Usage
<b>IP Device to Non-IP Device</b>	These calls require a voice compression channel for the duration of the call. If no channel is available, busy indication is returned to the caller.
<b>IP Device to IP Device</b>	<p>Call progress tones (for example dial tone, secondary dial tone, etc) do not require voice compression channels with the following exceptions:</p> <ul style="list-style-type: none"> <li>• Short code confirmation, ARS camp on and account code entry tones require a voice compression channel.</li> <li>• Devices using G723 require a voice compression channel for all tones except call waiting.</li> </ul> <p>When a call is connected:</p> <ul style="list-style-type: none"> <li>• If the IP devices use the same audio codec no voice compression channel is used.</li> <li>• If the devices use differing audio codecs, a voice compression channel is required for each.</li> </ul>
<b>Non-IP Device to Non-IP Device</b>	No voice compression channels are required.
<b>Music on Hold</b>	This is provided from the IP Office's TDM bus and therefore requires a voice compression channel when played to an IP device.
<b>Conference Resources and IP Devices</b>	Conferencing resources are managed by the conference chip which is on the IP Office's TDM bus. Therefore, a voice compression channel is required for each IP device involved in a conference. This includes services that use conference resources such as call listen, intrusion, call recording and silent monitoring.
<b>Page Calls to IP Device</b>	IP Office 4.0 and higher only uses G729a for page calls, therefore only requiring one channel but also only supporting pages to G729a capable devices.
<b>Voicemail Services and IP Devices</b>	Calls to the IP Office voicemail servers are treated as data calls from the TDM bus. Therefore calls from an IP device to voicemail require a voice compression channel.
<b>Fax Calls</b>	These are voice calls but with a slightly wider frequency range than spoken voice calls. IP Office only supports fax across IP between IP Office systems with the Fax Transport option selected. It does not currently support T38.
<b>T38 Fax Calls</b>	<p>Each T38 fax call uses a VCM channel.</p> <p>Within a Small Community Network, a T38 fax call can be converted to a call across an H323 SCN lines using the IP Office Fax Transport Support protocol. This conversion uses 2 VCM channels.</p> <p>In order use T38 Fax connection, the <b>Equipment Classification</b> of an analog extension connected to a fax machine can be set <b>Fax Machine</b>. Additionally, a new short code feature <b>Dial Fax</b> is available.</p>

### Measuring Channel Usage

The System Status Application can be used to display voice compression channel usage. Within the **Resources** section it displays the number of channel in use. It also displays how often there have been insufficient channels available and the last time such an event occurred.

On IP500 VCM cards, channel usage is also indicated by the LEDs (1 to 8) on the front of the [IP500 VCM card](#)<sup>215</sup>.

---

## 1.16 IP Office Software Applications

The IP Office applications are available on a number of DVDs. These can be ordered at a nominal cost to cover order processing and delivery. Separate installation packages for IP Office applications can also be [downloaded](#)<sup>67</sup> from the Avaya support website at <http://support.avaya.com>.

Title	Discs	Description	SAP Code
<b>IP Office Release 12.0 Admin and User DVD Set</b>	1	This DVD contain installation packages for all the main IP Office administration and user applications.	700513659
<b>IP Office Release 12.0 Server Edition Installation DVD</b>	2	Installation DVD for Server Edition and IP Office Application Server servers.	700513657
<b>Virtualized IP Office Server Edition DVD</b>	1	Installation DVD for virtualized Server Edition and IP Office Application Server servers.	700513658
<b>IP Office Linux Server TTS DVD Set</b>	3	Contains text to speech engines for use with Linux based Voicemail Pro's TTS functions.	-

- It is acceptable to make copies of the Avaya IP Office DVDs listed above. However the content must remain intact, unaltered and without change or addition. Avaya does not accept any liability and responsibility for damage or problems arising from the use of such copies.

## 1.16.1 Programming Applications

The following applications are used to program and maintain an IP Office system. Typically, they run on a PC connected to the IP Office system via its LAN interface. These applications are all provided on the IP Office Administrator Applications DVD.

Due to the nature of the applications, if installed on a PC at the customer site, this should be a secure PC or the PC of a trusted user. For maintainers, these applications can also be run remotely if a secure route for data connections to the customer's system exists.

- **IP Office Manager Version**

It is important to download and install the correct version of the IP Office administration suite including IP Office Manager.

- For system installation, you should use the version of IP Office Manager that matches the IP Office release required on the system. This sets the version of software loaded when [recreating the System SD card](#)<sup>77</sup>.
- For system maintenance, the version of IP Office Manager used sets the version of software uploaded to a system when [upgrading the system](#)<sup>177</sup>.
- For system configuration, IP Office Manager Version 12.0 is backwards compatible for systems running software from IP Office Release 6.0 upwards. IP Office Manager cannot load the configuration of an IP Office system running a higher version of software.

- **Admin Lite Not Supported**

Note that the IP Office Manager installed using the **AdminLite** installer is not the full version. It runs in English only and does not include the files needed for actions such as system upgrades, SD card recreation, etc. To fully support systems, ensure that you install the full IP Office Administration suite installer (approximately 1.52GB compared to the 230MB **AdminLite** installer).

### Applications

- [IP Office Manager](#)<sup>246</sup>

This tool is used to access all parts of the IP Office configuration. Different levels of access can be defined to control which parts of the configuration the IP Office Manager user can view and alter. IP Office Manager is also used to upgrade the software files used by an IP Office system.

- [IP Office Web Manager](#)<sup>74</sup>

The system configuration can be accessed via web browser using the same service user accounts as used for IP Office Manager. Currently, for non-basic mode IP500 V2 system, IP Office Web Manager can only be used to configure users, groups and service users (security accounts) and to perform basic maintenance actions. Therefore, IP Office Manager is still required for full system installation and maintenance.

- [System Status Application](#)<sup>248</sup>

This application can be used to inspect the current status of IP Office lines and extensions and to view records of recent alarms and events. It runs as a Java application.

- [Monitor \(SysMon\)](#)<sup>247</sup>

Monitor is a tool that can show a trace of all activity on the IP Office system in detail. As a consequence, interpretation of Monitor traces requires a high-level of data and telephony protocol knowledge. Despite that however, all IP Office installers and maintainers need to understand how to run Monitor when necessary as Avaya may request copies of Monitor traces to resolve support issues.

---

## 1.16.2 User Applications

The IP Office supports a number of applications that operate in parallel with users telephones. These applications are installed from the IP Office Applications DVD. The one-X Portal for IP Office server can also be installed as part of the IP Office Application DVD installation.

- **[one-X Portal for IP Office](#)**<sup>247</sup>  
This application is installed on an [IP Office Application Server](#)<sup>245</sup> server PC connected to the IP Office. Users can access the one-X portal from their own PC using a web browser. The application allows the user to control their phones, access voicemail messages, call logs and phone directories.
- **[SoftConsole](#)**<sup>248</sup>  
It is intended for telephone system operators or receptionists. It displays details of calls and allows them to quickly see the status of the callers required destination and transfer the call. The SoftConsole user is able to access a range of details about the status of users and groups on the IP Office system. Up to 4 simultaneous SoftConsole users are supported.
- **[Avaya Workplace Client](#)**<sup>244</sup>  
This is a unified communications application that runs on Windows, macOS, iOS and Android devices. It can be used as a softphone or to control a desk phone.
- **[IP Office User Portal](#)**<sup>250</sup>  
The user portal is a browser based application provided by the IP Office system. Individual users can use the application to see and change their own telephone settings. Which users can use the application and which feature they can access are controlled by settings in the IP Office system configuration.

## 1.16.3 Voicemail Applications

The IP Office supports a range of applications for the recording and playing of voicemail messages.

- **[Embedded Voicemail](#)**<sup>243</sup>  
Embedded voicemail supports basic voicemail mailbox operation, simple auto-attendants and announcements. Embedded Voicemail uses the Avaya SD card fitted to the system for storage of greetings, messages, announcements, etc.
- **[Voicemail Pro](#)**<sup>250</sup>  
This voicemail service runs on a [IP Office Application Server](#)<sup>245</sup> server PC connected to the IP Office. It support additional features such as call recordings and text-to-speech (TTS) and can be customized to provide special services. It requires various licenses entered into the IP Office configuration to control the features it offers and the number of simultaneous connections.
- **[Media Manager](#)**<sup>246</sup>  
Voicemail Pro can be used for manual and automatic call recording. Those recording are placed into mailboxes. Media Manager allows those recordings to be redirected to a separate store where details of each recording are maintained in a searchable database. This allows recordings to be archived, searched and played back separately from mailbox messages. This application requires entry of a additional licenses into the IP Office configuration. This application requires an IP Office Application Server including additional hard disk for storage of recordings.

## 1.16.4 Call Logging Applications

A wide range of 3rd -party applications exist to provide call logging and accounting for telephone systems. In addition, the IP Office provides an SMDR output.

- **SMDR Output**

The IP Office control unit can be configure to output SMDR records for each call to a specified IP address.

## 1.16.5 Call Center Applications

IP Office Essential Edition supports the following contact center applications:

- **Avaya Call Reporting**  <sup>243</sup>

Avaya Call Reporting provides call reporting and tracking through a set of 50 standard reports. It can also support a call recording library within the same reporting interface. Visual call center status display is provided through wallboards and agent dashboard displays.

## 1.16.6 CTI Applications

IP500 V2 systems support a range of CTI interfaces for connections to applications. These are provided through various API's and SDK's. See [https://www.devconnectprogram.com/site/global/products\\_resources/ip\\_office/interfaces/index.gsp](https://www.devconnectprogram.com/site/global/products_resources/ip_office/interfaces/index.gsp) for more details.

Simple interfaces such as SMDR and TAPI are supported without the need for any additional licenses or subscriptions.

- **TAPILink Pro**

TAPILink Pro provides provides third party CTI operation. This means that a single server can control and monitor any number of telephone devices. This requires entry of a CTI Link Pro license. TAPILink Pro also provides the ability to monitor and control groups. This allows an application to be notified when a call enters a queue, and can also redirect it to another location.

- **TAPI WAV driver**

Provides software-based support for voice processing. Purchasing the CTI Link Pro RFA license key also enables 4 ports of voice processing; additional ports can be purchased in 4 port increments. The TAPI-WAV driver is for use with TAPI 2.1 only; for TAPI 3.0, IP Office supports the Media Service Provider (MSP) interface, defined by Microsoft in TAPI 3.0.

- **DevLink Pro**

Provides a real-time event stream for calls and events on the system. The real-time event stream takes the form of a call record, which is issued whenever the state of any endpoint of a call changes (typically there are two endpoints on a call, but for some circumstances, such as conference calls, intruded calls there may be more).

---

## 1.17 Training

Avaya Learning provides a wide range of training courses for IP Office and associated applications. This includes courses necessary for IP Office resellers to become Avaya Authorized Channel Partners and for individuals to achieve IP Office certification.

Details of courses can be found on the Avaya Learning web site (<http://www.avaya-learning.com>). The site can be used to check course availability and to book course. It also includes on-line courses and on-line course assessments. The site requires users to setup a user name and password in order to track their personal training record.

## 1.18 Web Sites

Information to support the IP Office can be found on a number of web sites.

- **Avaya** (<http://www.avaya.com>)  
The official web site for Avaya. The front page also provides access to individual Avaya web sites for different countries.
- **Avaya Support** (<http://support.avaya.com>)  
Contains documentation and software downloads for Avaya products including IP Office. Copies of the IP Office software images are available from this site and updated core software files.
- **Avaya Documentation** (<https://documentation.avaya.com>)  
Contains Avaya product user guides and technical manuals in HTML format.
- **Avaya IP Office Knowledge Base** (<https://ipofficekb.avaya.com>)  
Contains IP Office user guides and technical manuals in HTML and PDF formats.
- **Avaya Learning** (<http://www.avaya-learning.com>)  
This site provides access to the full range of Avaya training courses. That includes both on-line courses, course assessments and access to details of classroom based courses. The site requires users to register in order to provide the user with access to details of their training record.
- **International Avaya Users Group** (<https://iaug.org>)  
This is the official discussion forum for Avaya product users. However it does not include any separate area for discussion of IP Office issues.
- **Avaya Product Compatibility Matrix** (<https://secureservices.avaya.com/compatibility-matrix/menus/product.xhtml>)
- **Other Non-Avaya Web Sites**  
A number of third-party web forums exist that discuss IP Office. These can act as useful source of information about how the IP Office is used. Some of these forums require you to be a member and to register. These are not official Avaya forums and their content is not monitored or sanctioned by Avaya.
  - **Tek-Tips** (<http://www.tek-tips.com>)
  - **IP Office Info** (<http://www.ipofficeinfo.com>)

## 1.19 Emergency and Power Failure Ports

IP Office systems provide 2 types of analog extension power failure ports. In all cases these only work with loop-start analog trunks. Any phones connected to these ports should be clearly labeled as power fail extensions in accordance with the appropriate national and local regulatory requirements.

### Switching Power Failure Ports

During normal operation, these ports can be used for normal analog phone connection. During power failure, the ports connect directly to an analog trunk port.

This type of power failure port is provided by the following cards:

- **IP500 Analog Phone 8 Card**  
When an IP500 Analog Phone 8 base card is fitted with an IP500 Analog Trunk daughter card, during power failure extension port 8 is connected to analog trunk port 12.
- **IP500 ATM Combination Card/IP500 ATM Combination Card V2**  
On this card, during power failure, extension port 8 is connected to analog trunk port 12.

### Emergency Only Power Failure Ports

During normal operation, these ports cannot be used. During power failure, the ports connect directly to an analog trunk port.

- **IP500 Analog Trunk Daughter Card/IP500 Analog Trunk Daughter Card V2**  
Regardless of the IP500 card hosting it, during power failure pins 4 and 5 of port 12 are connected to pins 7 and 8.



# Chapter 2.

# Installation Overview

---

## 2. Installation Overview

This installation process is a simple outline. Many steps can be completed before the actual installation at the customer site.

### Installation process summary

#### 1. System SD Card Licensing

- a. Obtain an IP Office System SD card.
- b. Using the card's PLDS ID number, obtain a license file for the required release of IP Office software. The file needs to include an IP Office Essential Edition license plus licenses for any other features required.

#### 2. [Prepare for installation](#)<sup>50</sup>

- a. [Environmental Requirements](#)<sup>51</sup>  
Check that the installation area meets the system environmental requirements.
- b. [Space Requirements](#)<sup>53</sup>  
Check that the installation area meets the system space requirements.
- c. [Tools and Parts Required](#)<sup>61</sup>  
Check that you have the tools and additional parts required.
- d. [Documentation](#)<sup>62</sup>  
Ensure that you have obtained and read all the relevant documentation.
- e. [Unpacking](#)<sup>63</sup>  
Check that all the required equipment has been delivered and that there is no damage.

#### 3. [Admin Software Installation](#)<sup>66</sup>

For system installation you need a PC with the IP Office administrator software installed. This must include a copy of IP Office Manager that matches the IP Office software level required.

- a. [Downloading the Software](#)<sup>67</sup>
- b. [Installing the Administrator Applications](#)<sup>68</sup>

#### 3. [Preparing the System SD card](#)<sup>76</sup>

Upgrade the System SD card to the required release of IP Office software.

#### 4. [Install the control unit cards](#)<sup>84</sup>

Attach any trunk daughter cards to their IP500 base cards and insert the base cards into the control unit.

#### 5. [Install the system](#)<sup>88</sup>

- a. [Wall Mounting](#)<sup>89</sup>  
If wall mounting, attach the brackets and fit the unit to the wall.
- b. [Rack Mounting](#)<sup>91</sup>  
If rack mounting, attach the brackets and fit the control unit into the rack.
- c. [Connect the External Expansion Modules](#)<sup>93</sup>  
Connect the external expansions modules to the control unit.
- d. [Ground the system](#)<sup>95</sup>  
Attach required ground cables to the control unit and external expansion modules.
- e. [Starting the System](#)<sup>96</sup>  
Insert the System SD card and power up the system.
- f. [Connecting Phones](#)<sup>99</sup>  
Connect the Avaya digital phones.

#### 6. Initial Configuration

Once the physical system is started, it can be configured. This can be done using either [IP Office Manager](#)<sup>102</sup> or [IP Office Web Manager](#)<sup>114</sup>.

## 2.1 Environmental Requirements

The planned location must meet the following requirements. If being installed into a rack system, these are requirements for within the rack:

1.  Temperature: Operating 5°C to 40°C (Storage -40°C to 70°C).
2.  Relative Humidity: Operating 10% to 90% (Storage 5% to 95%).
3.  Check there are no flammable materials in the area.
4.  Check there is no possibility of flooding.
5.  Check that no other machinery or equipment needs to be moved first.
6.  Check that it is not an excessively dusty atmosphere.
7.  Check that the area is unlikely to suffer rapid changes in temperature and humidity.
8.  Check for the proximity of strong magnetic fields, sources of radio frequency and other electrical interference.
9.  Check there are no corrosive chemicals or gasses.
10.  Check there is no excessive vibration or potential of excessive vibration, especially of any mounting surface.
11.  Check that where telephones are installed in another building, that the appropriate protectors and protective grounds are fitted (see [Out of Building Telephone Installation](#)<sup>36</sup>).
12.  Check there is suitable lighting for installation, system programming and future maintenance.
13.  Check that there is sufficient working space for installation and future maintenance.
14.  Ensure that likely activities near the system will not cause any problems. For example, access to and maintenance of any other equipment in the area.
15.  Where ventilation holes are present on any of the IP Office units, those holes should not be covered or blocked.
16.  The surface must be flat horizontal for free-standing or rack mounted installations.

### Rack Mounting

1. Rack Positioning - Ensure compliance with the rack manufacturers safety instructions. For example check that the rack legs have been lowered and fixing brackets have been used to stop toppling.
2. Elevated Operating Ambient - If installed in a closed or multi-unit rack assembly, the operating ambient temperature of the rack environment may be greater than room ambient. Therefore, consideration should be given to installing the equipment in an environment compatible with the maximum ambient temperature (T<sub>ma</sub>) specified by the manufacturer.
  - Operating Temperature: 5°C (40°F) to 40°C (104°F).
  - Operating Humidity: 10% to 95% non-condensing.
3. Reduced Air Flow - Installation of the equipment in a rack should be such that the amount of air flow required for safe operation of the equipment is not compromised. Proper ventilation must be maintained. The side ventilation slots on the IP500 control unit should not be covered or blocked.
4. Mechanical Loading - Mounting of the equipment in the rack should be such that a hazardous condition is not achieved due to uneven mechanical loading.
5. Circuit Overloading - Consideration should be given to the connection of the equipment to the supply circuit and the effect that overloading of the circuits might have on overcurrent protection and supply wiring. Appropriate consideration of equipment nameplate ratings should be used when addressing this concern.
6. Reliable Earthing - Reliable earthing of rack-mounted equipment should be maintained. Particular attention should be given to supply connections other than direct connections to the branch circuit (e.g. use of power strips).
7.  Only the screws provided with the mounting kit should used to attach the brackets to the control unit.

---

## Wall Mounting

In addition to the requirements above, the following are applicable to IP Office units that support wall mounting.

1. Units must only be mounted onto permanent wall surfaces.
2. The surface must be vertical and flat.
3. Orientation of the unit must be as shown in the section on [IP500 Wall Mounting](#)<sup>89</sup>.
4. The appropriate Avaya wall mounting kits must be used.

## IMPORTANT SAFETY INSTRUCTIONS

When using your telephone equipment, basic safety precautions should always be followed to reduce the risk of fire, electric shock and injury to persons, including the following:

1. Do not use this product near water, for example, near a bath tub, wash bowl, kitchen sink or laundry tub, in a wet basement or near a swimming pool.
2. Avoid using a telephone (other than a cordless type) during an electrical storm. There may be a remote risk of electric shock from lightning.
3. Do not use the telephone to report a gas leak in the vicinity of the leak.
4. Use only the power cord and batteries indicated in this manual.

## 2.2 Space Requirements

IP Office control units and modules are designed to be installed either in a free-standing stack or into a 19" rack system. Rack installation requires a [rack mounting kit](#)<sup>37</sup> for each control unit and expansion module.

- **Cable Clearance**

Clearance must be provided at the front and rear for cable access. On control units, allow a minimum clearance of 90mm (3.5 inches). On external expansion modules allow 75mm (3 inches).

- **Additional Clearance**

Care should be taken to ensure that the positioning of the modules does not interrupt air flow and other factors that may affect [environmental requirements](#)<sup>51</sup>. This is especially important for control units as these have ventilation slots on both sides and the rear.

- **Cable Access**

Power cords must not be attached to the building surface or run through walls, ceilings, floors and similar openings. Installation measures must be taken to prevent physical damage to the power supply cord, including proper routing of the power supply cord and provision of a socket outlet near the fixed equipment or positioning of the equipment near a socket outlet.

### 2.2.1 Control Unit

The ventilation slots on the rear and sides should not be covered or blocked.

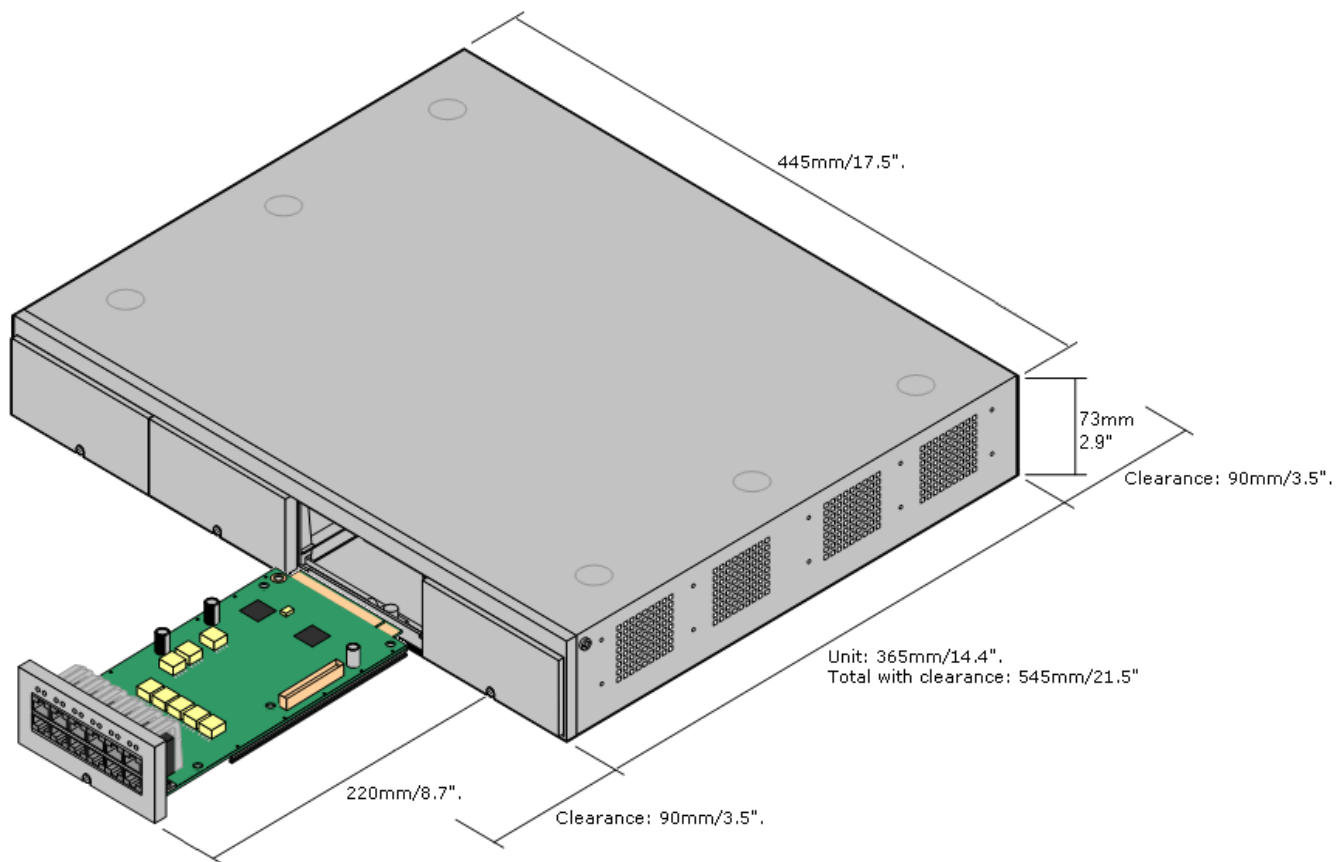

## 2.2.2 External Expansion Modules

The dimensions below are applicable to all IP Office external expansion modules.

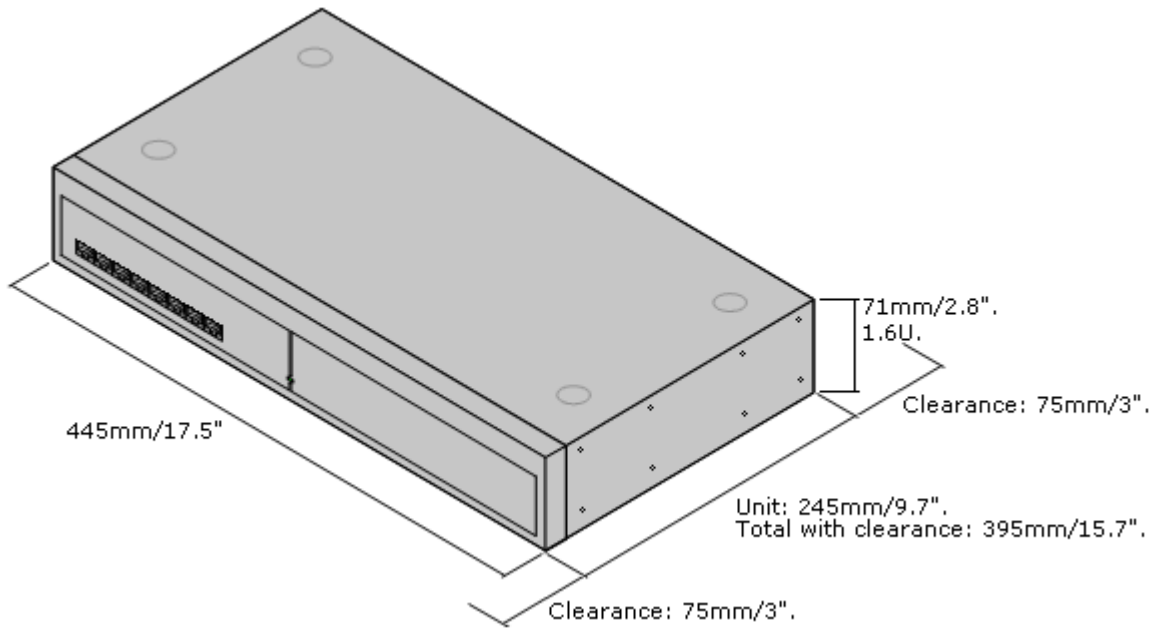

For free-standing systems, the external expansion modules can be stacked on top of the control unit. For that, and for rack mounted systems, the diagram below shows the recommended options to accommodate the length of the module interconnect cable.

The integral expansion ports on a control unit are located on the rear of the unit. An additional 4 expansion ports can be added to the front of the control unit by installing an IP500 4-Port Expansion card.

- Each external expansion module is supplied with a blue 1 meter (3'3") expansion interconnect cable. This cable must be used when connecting to expansion ports on the rear of a control unit.
- When connecting to expansion ports on an IP500 4-Port Expansion card, a supplied yellow 2 meter (6'6") expansion interconnect cable can be used in place of the supplied blue cable. 4 Yellow cables are supplied with the IP500 4-Port Expansion card.

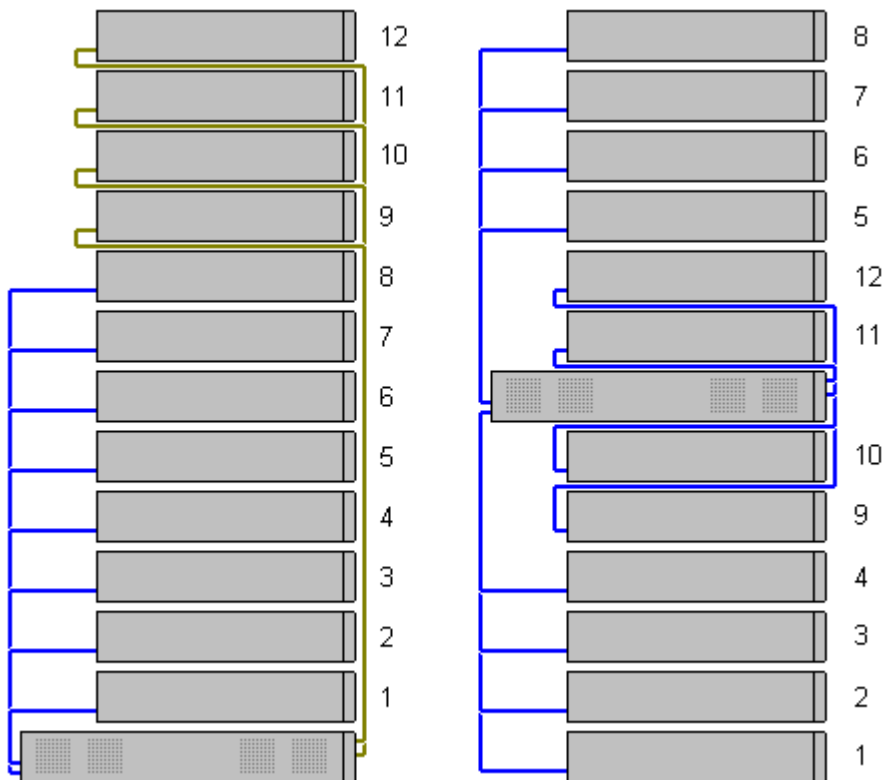

### Supported Expansion Modules:

The 4-Port Expansion card supports the following external expansion modules:

- IP500 Analogue Trunk Module.
- IP500 BRI So Module.

- IP500 Digital Station Module.
- IP500 Digital Station Module A.
- IP500 Digital Station Module B.
- IP500 Phone Module.

---

## 2.2.3 Wall Mounting

IP500 V2 control units and IP500 external expansion modules can be wall or rack mounted. To do this, a wall mounting kit is required in addition to suitable wall fixings.

In addition to the existing [environmental requirements](#)<sup>51</sup> for an IP Office system, the following additional requirements apply when wall mounting a unit:

- The wall surface must be vertical, flat and vibration free. Attachment to temporary walls is not supported.
- Only the screws provided with the mounting kit should be used to attach the brackets to the control unit or expansion modules.
- The installation must be done by a service person.
- Ensure that the system has been shut down and power has been removed from all the units. Shut down the system using a shutdown command and then remove the power. Do not simply remove the power.
- A suitable plywood mounting surface of at least 1m x 1m x 19mm (39" x 39" x 0.75") is required. If an expansion box is being mounted as well a plywood mounting surface of at least 1.2m x 1.2m x 19mm (48" x 48" x 0.75") is required.
- A minimum of 6 x 45mm long 5mm/6mm ( 1.75" #10/#12) pan head screws must be used to secure the plywood to the wall studs.
- The supplied 20mm long 4mm (#8 3/4") wood screws must be used to secure the brackets to the plywood mounting surface

The following kit is currently available:

- **IPO IP500 WALL MNTG KIT V3** (SAP Code 700503160)  
This kit can be used for wall and rack mounting of IP500 V2 control units and IP500 external expansion modules. The kit incorporates cable routing at the front and rear of the unit. For wall mounted control units, it allows orientation of the control unit base card slots to the left or to the right.

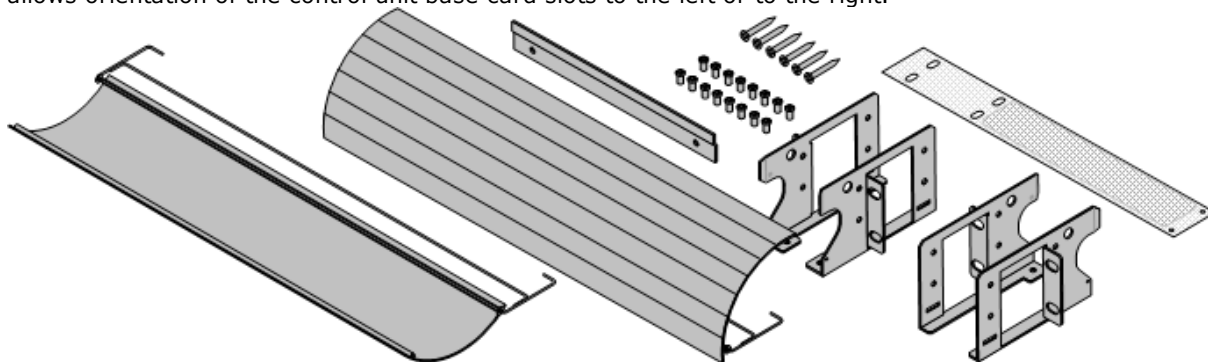

Wall Mounting Space Requirement

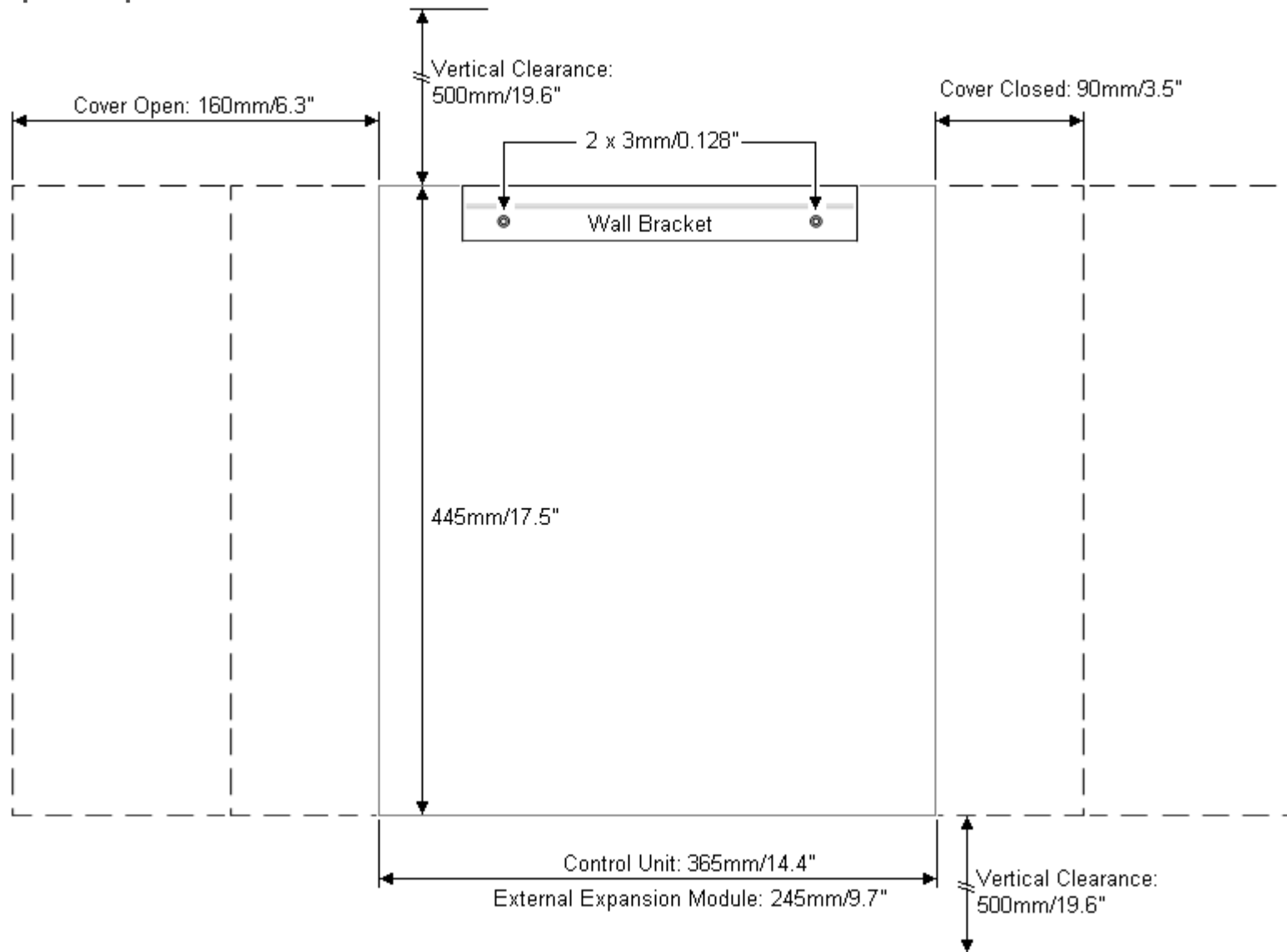



## 2.2.4 Rack Space Requirements

All IP Office control units and external expansion modules can be rack mounted into standard 19" rack systems. Each unit requires a 2U slot space within the rack. Rack mounting requires a kit for each control unit and external expansion module.

Where systems are being rack mounted, the effect of conditions within the rack cabinet must be considered. For example, the rack temperature may be above the room temperature and airflow within the rack is restricted. The [environmental requirements](#)<sup>51</sup> for the individual IP Office units are still applicable inside the rack cabinet.

- IPO IP500 WALL MNTG KIT V3 (SAP Code 700503160)**  
 This kit can be used for [wall and rack mounting](#) of IP500 V2 control units and IP500 external expansion modules. The kit incorporates cable routing at the front and rear of the unit. For wall mounted control units, it allows orientation of the control unit base card slots to the left or to the right.

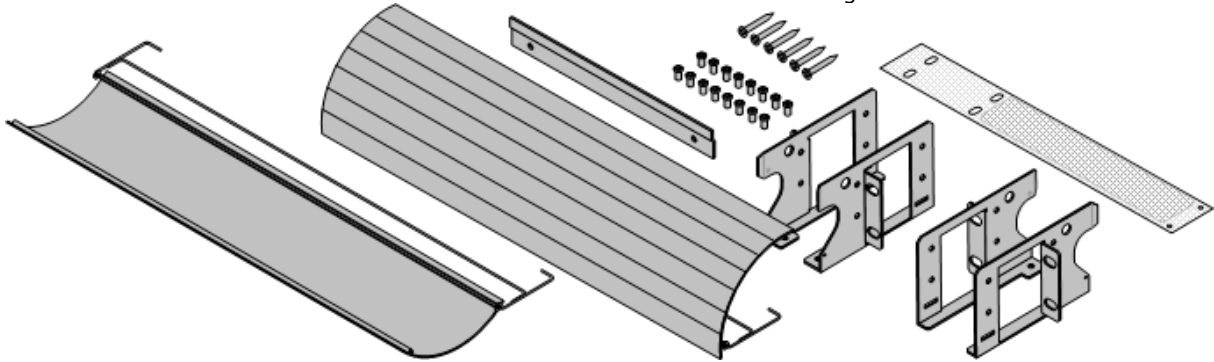

- IPO IP500 RACK MNTG KIT (SAP Code 700429202)**  
 This kit contains all the components required for the rack mounting of a single IP500 V2 control unit or IP500 external expansion module. This includes screws for fixing of the brackets to the module, bolts for securing the module in the rack and cable tidy brackets..

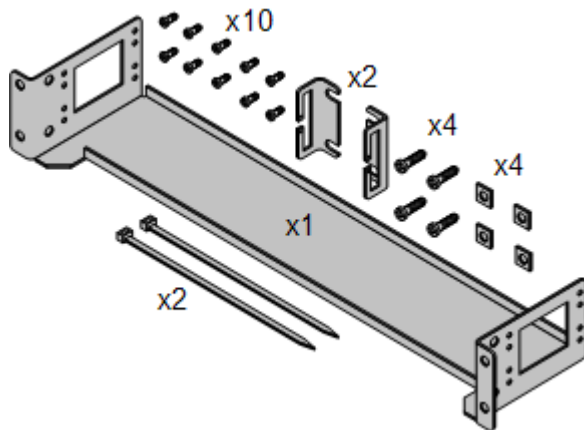

### Barrier Box Rack Mounting Kit

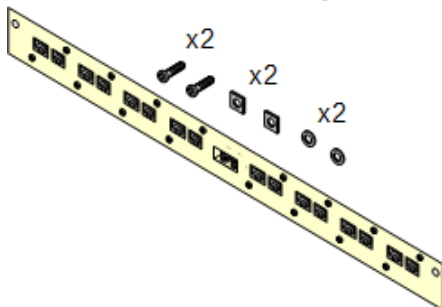

- Barrier Box Rack Mounting Kit (SAP 700293905)**  
 Barrier boxes must be used for [out-of-building analog phone extensions](#)<sup>36</sup>. This bracket allows up to 8 IP Office barrier boxes to be rack mounted and simplifies the number of connections to the protective ground point in the rack. This kit must be used when more than 3 barrier boxes are in use and supports a maximum of 16 barrier boxes for a single external expansion module.

## Rack Module Positioning

The integral expansion ports on a control unit are located on the rear of the unit. An additional 4 expansion ports can be added to the front of the control unit by installing an IP500 4-Port Expansion card.

- Each external expansion module is supplied with a blue 1 meter (3'3") expansion interconnect cable. This cable must be used when connecting to expansion ports on the rear of a control unit.
- When connecting to expansion ports on an IP500 4-Port Expansion card, a supplied yellow 2 meter (6'6") expansion interconnect cable can be used in place of the supplied blue cable. 4 Yellow cables are supplied with the IP500 4-Port Expansion card.

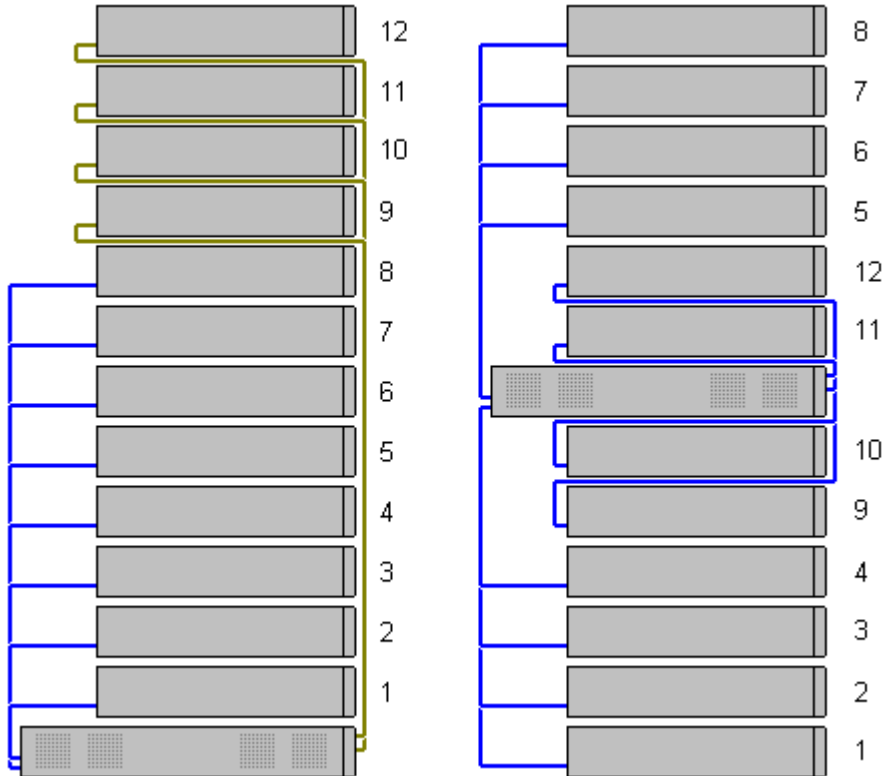

### Supported Expansion Modules:

The 4-Port Expansion card supports the following external expansion modules:

- IP500 Analogue Trunk Module.
- IP500 BRI So Module.
- IP500 Digital Station Module.
- IP500 Digital Station Module A.
- IP500 Digital Station Module B.
- IP500 Phone Module.

## 2.3 Tools and Parts Required



The following is a general summary of the tools required. Additional tools and equipment will be required for wall and or rack mounting and to fashion ground cable connections suitable to local requirements.

### IP Office Parts

The minimum parts required are:

- [IP500 V2 Control Unit](#)<sup>203</sup>
- [Avaya SD Card](#)<sup>206</sup>
- [PLDS License File](#)<sup>269</sup>

A file is needed if any licensed features are required. The file must be appropriate for the release of software being licensed. Note that includes the license for IP Office Essential Edition and, if required, IP Office Preferred Edition.

- The card's ID number is printed on the card's label after **PLDS ID**, **FK SN** or **FK** depending on the age of the card. On newer cards is a 12-digit number. Older cards may have a 10-digit number. For PLDS licensing, use the 12-digit number. On older cards, for licensing, prefix the 10-digit number with **11**.

### Tools Required

- 5mm Flat-blade screwdriver.
- Crosshead screwdriver.
- Anti-static wrist strap and ground point.
- RJ45-RJ45 Ethernet LAN Cable.
- M4 Cross-Head Screwdriver.
- Tools suitable for crimping a cable spade.
- If wall mounting, drills and tools for wall mounting fixtures.

### System Administration

- Windows PC with:
  - [IP Office Admin suite installed](#)<sup>68</sup>.
  - RJ45 Ethernet LAN port.
  - SD Card reader.

### Additional Parts Required

In addition to orderable IP Office equipment, the following items will be required.

- 14AWG Solid copper wire for ground connection of control units and expansion modules.
- Cable sleeve matching local regulator requirements for ground wires. Typically green for a functional ground and green/yellow for a protective ground.
- If wall mounting, additional fixtures and fittings suitable for the wall type and mounting kit being used.
- Cable ties and labels for tidying and identifying cables.

---

## 2.4 Documentation

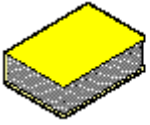

Ensure that you have read this manual in full before starting installation. Also include the installation documentation for any other equipment and applications being installed as part of the IP Office system.

IP Office documentation is available from the following web sites.

- **Avaya Support** (<http://support.avaya.com>)  
Contains documentation and software downloads for Avaya products including IP Office. Copies of the IP Office software images are available from this site and updated core software files.
  - **Avaya Documentation** (<https://documentation.avaya.com>)  
Contains Avaya product user guides and technical manuals in HTML format.
  - **Avaya IP Office Knowledge Base** (<https://ipofficekb.avaya.com>)  
Contains IP Office user guides and technical manuals in HTML and PDF formats.
- 
- **! IP Office Technical Bulletins**  
You must obtain and read the IP Office Technical Bulletin relating to the IP Office software release which intend to install. The bulletin contains important information that may not have been included in this manual. IP Office Technical Bulletins are available from the [Avaya support](http://support.avaya.com) website (<http://support.avaya.com>).

## 2.5 Unpacking

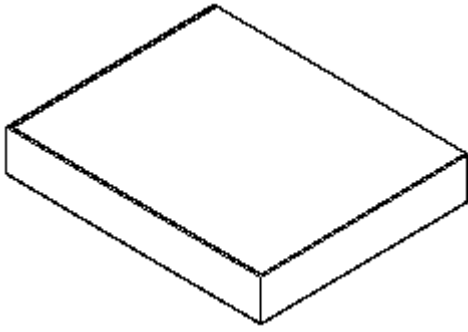

Use the following procedure when unpacking any equipment supplied by Avaya or an Avaya reseller or distributor.

### Information Required

- **Equipment Checklist.**  
An installation checklist of the parts and equipment ordered for the installation.

### Procedure

1.  **Check for Packaging Damage**  
Before unpacking any equipment, check for any signs of damage that may have occurred during transit. If any damage exists bring it to the attention of the carrier.
2.  **Check the Correct Parts Have Been Delivered**  
Check all cartons against the packing slip and ensure that you have the correct items. Report any errors or omissions to the equipment supplier.
3.  **Retain All Packaging and Documentation**  
While unpacking the equipment, retain all the packaging material. Fault returns are only accepted if repackaged in the original packaging. If performing a staged installation, the original packaging also assists when repacking equipment to move it to the final installation site.
4.  **Ensure that Anti-Static Protection Measures are Observed**  
Ensure that anti-static protection measures are observed at all times when handling equipment with exposed electrical circuit boards.
5.  **Check All Parts**  
Visually inspect each item and check that all the necessary documentation and accessory items have been included. Report any errors or omissions to the dealer who supplied the equipment.
6.  **Check All Documentation**  
Ensure that you read and retain any documentation included with the equipment.



# Chapter 3.

## Installing the Administrator Software

---

## 3. Installing the Administrator Software

In order to install and maintain an IP Office system you must be familiar with using the following applications.

- **IP Office Manager**

This is a Windows based application. IP Office Manager is used to access all parts of the IP Office configuration. Different levels of access can be defined to control which parts of the configuration the user can view and alter. IP Office Manager is also used to upgrade the software files used by an IP Office system.

- **IP Office Manager Version**

It is important to download and install the correct version of the IP Office administration suite including IP Office Manager.

- For system installation, you should use the version of IP Office Manager that matches the IP Office release required on the system. This sets the version of software loaded when [recreating the System SD card](#)<sup>77</sup>.
    - For system maintenance, the version of IP Office Manager used sets the version of software uploaded to a system when [upgrading the system](#)<sup>77</sup>.
    - For system configuration, IP Office Manager Version 12.0 is backwards compatible for systems running software from IP Office Release 6.0 upwards. IP Office Manager cannot load the configuration of an IP Office system running a higher version of software.

- **Admin Lite Not Supported**

Note that the IP Office Manager installed using the **AdminLite** installer is not the full version. It runs in English only and does not include the files needed for actions such as system upgrades, SD card recreation, etc. To fully support systems, ensure that you install the full IP Office Administration suite installer (approximately 1.52GB compared to the 230MB **AdminLite** installer).

- **IP Office Web Manager**

Following installation, the configuration for an IP500 V2 system can also be accessed via web browser using the same service user accounts as used for IP Office Manager.

- **System Status Application**

System Status Application (SSA) is a reporting tool that provides a wide range of information about the current status of an IP Office system. It reports the available resources and components within the system and details of calls in progress. Details of alarms current and historical alarms are shown. When required for diagnostics escalation, SSA can take a snap shot image of the IP Office system's status including a copy of its current configuration.

- **Monitor (System Monitor)**

System Monitor is a tool that can show the activity on the IP Office system in great detail. As a consequence, interpretation of traces requires a high-level of data and telephony protocol knowledge. However, all IP Office installers and maintainers must know how to run Monitor to capture a trace as Avaya may request those traces to investigate support issues.

## 3.1 Downloading the Software

The IP Office administration suite of software is available as an [orderable DVD](#)<sup>42</sup>. However, the software can also be downloaded from the Avaya support website (<http://support.avaya.com>).

- **IP Office Manager Version**

It is important to download and install the correct version of the IP Office administration suite including IP Office Manager.

- For system installation, you should use the version of IP Office Manager that matches the IP Office release required on the system. This sets the version of software loaded when [recreating the System SD card](#)<sup>77</sup>.
- For system maintenance, the version of IP Office Manager used sets the version of software uploaded to a system when [upgrading the system](#)<sup>177</sup>.
- For system configuration, IP Office Manager Version 12.0 is backwards compatible for systems running software from IP Office Release 6.0 upwards. IP Office Manager cannot load the configuration of an IP Office system running a higher version of software.

- **Admin Lite Not Supported**

Note that the IP Office Manager installed using the **AdminLite** installer is not the full version. It runs in English only and does not include the files needed for actions such as system upgrades, SD card recreation, etc. To fully support systems, ensure that you install the full IP Office Administration suite installer (approximately 1.52GB compared to the 230MB **AdminLite** installer).

- **! IP Office Technical Bulletins**

You must obtain and read the IP Office Technical Bulletin relating to the IP Office software release which intend to install. The bulletin contains important information that may not have been included in this manual. IP Office Technical Bulletins are available from the [Avaya support](#) website (<http://support.avaya.com>).

### To download Avaya software:

1. Browse to <http://support.avaya.com> and log in.
2. Select **Support by Product** and click **Downloads**.
3. Enter **IP Office** in the **Enter Product Name** box and select the matching option from the displayed list.
4. Use the **Choose Release** drop-down to select the required IP Office release.
5. Click **Downloads**. The page lists the most recently available downloads.
6. Click **View Downloads** for the full list of downloads.
7. Select the required software package for download.
8. The page displayed in a new tab or window, details the options for downloading that software. For IP500 installation, download the full administration package, not the separate binary files or the Admin lite download packages.
9. Also download the documents listed under the **RELATED DOCUMENTS** heading if shown.

---

## 3.2 Installing the Administrator Applications

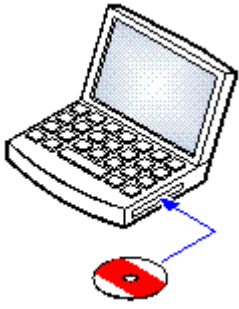

The IP Office Administration suite consists of a number of applications for IP Office installers and maintainers.

- **System Monitor** - *Install* ✓
- **IP Office Manager** - *Install* ✓
- **System Status** - *Install* ✓

### Requirements

- **IP Office Admin Suite**

The IP Office Admin Suite can be downloaded from [Avaya's support website \(http://support.avaya.com\)](http://support.avaya.com).

- **Windows PC Requirements**

The specifications below are the minimum requirements for IP Office Manager. If other applications are to be installed on the PC their individual requirements should also be met. The supported versions of Windows are listed in the [Operating Systems](#) section.

- **Standard Manager:** Core i3 CPU, 4GB RAM, 32/64-bit OS
- **Server Edition Manager:** Core i5 CPU, 6GB RAM , 32/64-bit OS
- **Server Edition Select Manager:** Core i5 CPU, 8GB RAM, 64-bit OS
- IP Office Manager is only supported on Windows set to 100% font size display.
- System Status Application requires Java to also be installed on the PC. It is not installed by the admin suite installer. This can be the run-time edition (JRE) or developers kit (JDK). The application has been tested with Oracle and Azul Zulu versions of Java. The presence of Java can be tested using the command **java -version**.

**To install the IP Office administrator applications:**

1. Unzip the installer package.
2. Right-click on setup.exe file and select **Run as administrator**.
3. Select the language for the installation process. This does not affect the language used by IP Office Manager when running. Click **Next >**.
4. If you agree, click **I accept the terms in the license agreement** and then click **Next >**.
5. If required, change the destination to which the applications should be installed. We recommend that you accept the default destination. Click **Next >**.
6. The next screen is used to select which applications should be installed. Clicking on each will display a description of the application. Click on the ▼ next to each application to change the installation selection. When you have selected the installations required, click **Next >**.

- **Manager**

Install the basis IP Office Manager application required for editing system configurations plus any of the following:

- **Memory Cards**

Install the files needed to recreate an Avaya System SD card.

- **Manager Help Files**

Install the application help files in all available languages. If not selected, only English is installed.

- **IP Office Firmware Files**

Install the firmware files used by IP Office external expansion modules. These files are only need if IP Office Manager is to be used for system upgrades.

- **Phone Firmware Files**

Install the firmware files used by the various Avaya IP telephones supported by IP Office. These files are only need if IP Office Manager is to be used for system upgrades.

- **Embedded Voicemail Audio Files**

Install the voicemail prompts used by Embedded Voicemail. These files are only need if IP Office Manager is to be used for system upgrades.

- **Web Manager**

Install a copy of the files that need to be loaded onto a system for it to run IP Office Web Manager.

- **System Monitor**

Install the System Monitor application.

- **System Status Application**

Install the System Status Application application.

- System Status Application requires Java to also be installed on the PC. It is not installed by the admin suite installer. This can be the run-time edition (JRE) or developers kit (JDK). The application has been tested with Oracle and Azul Zulu versions of Java. The presence of Java can be tested using the command **java -version**.

7. Ensure that at minimum **System Monitor** and **Manager** are selected. Click **Next >**.
8. Click **Install**. If the installation requires other components such as Windows .Net, follow the prompts to install those components.
9. If requested, reboot the PC.
10. Click **Finish**.

### 3.3 Installer PC Connection

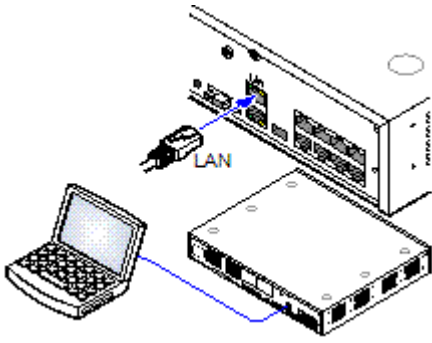

During installation it is recommended that the IP Office control unit is started without it being connected to any network. That ensures that the IP Office defaults to a known set of IP address settings.

If the IP Office is started connected to a network with a DHCP server, the programming PC will need to be connected to the same network as either a DHCP client or with an IP address valid for that network.

This section covers connecting your installation PC directly to the IP Office control unit.

#### Requirements

- **IP Office Administration PC**  
A Windows PC with the [IP Office Administrator Application suite installed](#)<sup>68</sup>.
- **LAN Cable**

#### To connect directly to a defaulted IP Office system:

1. The default address for the IP Office control unit LAN port is 192.168.42.1/255.255.255.0. To directly connect a PC, change the TCP/IP properties for the PC's LAN port to the following:

<b>Fixed IP address</b>	192.168.42.203
<b>Subnet mask</b>	255.255.255.0
<b>Default gateway</b>	192.168.42.1.

- While setting the PC to be a DHCP client could be used, this is not recommended for performing more advanced functions such as firmware upgrades.
2. Connect the LAN cable from the PC's LAN port to the LAN port on the IP Office control unit.
3. Check that the orange LED lamp on the IP Office LAN port is on. The green LED may also be flickering as it indicates traffic across the LAN connection.
4. To test the connection before running IP Office Manager or System Status Application:
  - Right-click on the start icon and select **Run**. Enter **cmd**.
  - In the command window that appears, enter ping **192.168.42.1**. The results should show a number of ping replies from the IP Office. This confirms basic communication between the IP Office Manager PC and the IP Office.
  - If there are no ping replies, enter **ipconfig**. The results should list the IP address settings of the IP Office Manager PC as required above. If they do, enter **exit** and check the cable connection.
5. You can now start [IP Office Manager](#)<sup>71</sup>, [System Status](#)<sup>72</sup> or [System Monitor](#)<sup>73</sup>.

## 3.4 Starting IP Office Manager



IP Office Manager is used to access all parts of the IP Office configuration. IP Office Manager can also be used to upgrade the software files used by an IP Office system.

### Requirements

- **IP Office Administration PC**  
A Windows PC with the [IP Office Administrator Application suite installed](#)<sup>68</sup>.
- **LAN Cable**

### To login to a system using IP Office Manager:

1. Select **Start | All Programs | IP Office | Manager**.
2. If the PC has firewall software installed, you may be prompted as to whether you want to allow this program to access the network. Select **Yes** or **OK**.
3. Select **File | Open Configuration** from the menu bar.
4. The **Select IP Office** window appears. After a few seconds it should list the IP Office control unit. The default display name used for a newly installed IP Office control unit is its MAC address.

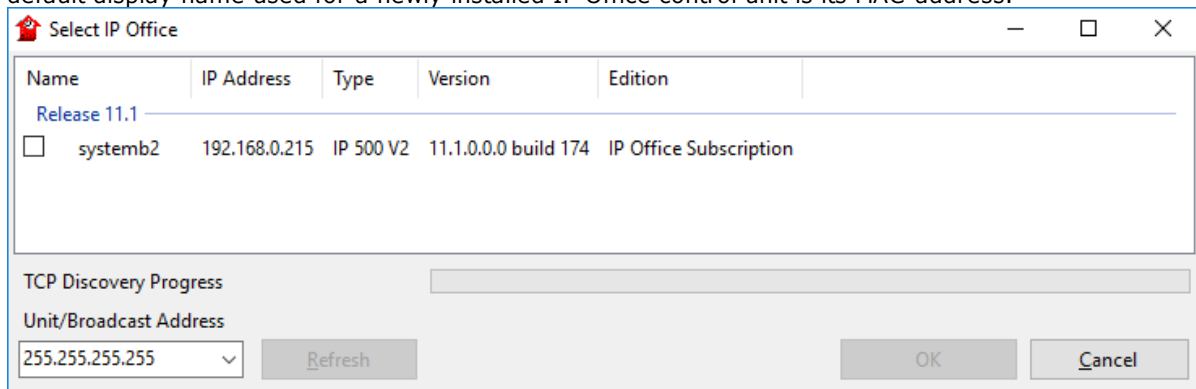

- If the system required was not found, the address used for the search can be changed. Enter or select the required address in the **Unit/Broadcast Address** field and then click **Refresh** to perform a new search.
5. Click the check the box next to the system and then click **OK**.
  6. The name and password request is displayed. The name and password must match one of those setup through the the system's security settings.

## 3.5 Starting the System Status Application



The System Status Application (SSA) is a reporting tool that provides a wide range of information about the current status of an IP Office system. It can report the available resources and components within the system and details of calls in progress. Details of the number of alarms are recorded plus the time date of the most recent alarms.

When required for diagnostics escalation, SSA is able to take a snap shot image of the system's status including a copy of its current configuration. Use of SSA requires an IP Office service user name and password that has been configured for System Status access in the IP Office's security settings.

For full details of using System Status Application, refer to the using ["Using IP Office System Status"](#) manual.

- System Status Application requires Java to also be installed on the PC. It is not installed by the admin suite installer. This can be the run-time edition (JRE) or developers kit (JDK). The application has been tested with Oracle and Azul Zulu versions of Java. The presence of Java can be tested using the command **java -version**.

### To start System Status:

1. There are several methods that can be used to start the System Status Application.
  - On a PC where [System Status has been installed](#)<sup>68</sup>, select **Start | Programs | IP Office | System Status**.
  - If IP Office Manager is also installed on the PC and is running, select **File | Advanced | System Status**.
  - In a web browser, enter the IP address of the control unit. Select the link for the **System Status**.
  - If already running IP Office Web Manager, select **Monitoring** and click **System Status**.
2. Once System Status has started, it will request the details of the IP Office system to which you want it to connect.

- **Control Unit IP Address**  
Enter the IP address of the IP Office control units LAN interface or use the drop down to select a previously used address.
  - **Services Base TCP Port**  
This should match the Services Base TCP Port setting set in the IP Office system's security settings. The default is 50804.
  - **Local IP Address**  
If the PC has more than one IP address assigned to its network card or multiple network cards, the address to use can be selected if necessary.
  - **User Name/Password**  
Enter a user name and password that has been provided for System Status usage. By default this is the same as the user name and password used with IP Office Manager. This must be the name of an IP Office service user name that has been configured for system status access in the IP Office's security settings.
  - **Auto Reconnect**  
If selected, System Status Application attempts to reconnect using the same settings if connection to the system is lost.
  - **Secure Connection**  
Use an encrypted TLS connection to the system. If selected and the system is not configured for secure access, System Status Application offers to reattempt connection using unsecure access instead.
3. Enter the required details for the IP Office and click **Logon**.

### 3.6 Starting System Monitor

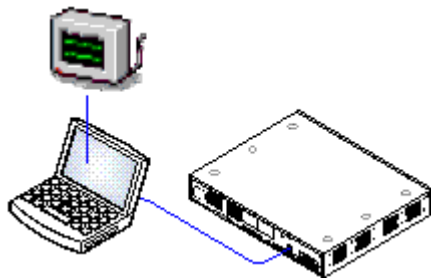

System Monitor is a tool that can show all activity on the IP Office system in great detail. As a consequence, interpretation of Monitor traces requires a high-level of data and telephony protocol knowledge. However, all IP Office installers and maintainers must understand how to run Monitor when necessary as Avaya may request copies of Monitor traces to resolve support issues.

For full details of using System Monitor, refer to the using ["Using IP Office System Monitor"](#) manual.

#### Requirements

- **IP Office Administration PC**  
A Windows PC with the [IP Office Administrator Application suite installed](#)<sup>68</sup>.
- **LAN Cable**

#### 1. To start System Monitor:

1. Select **Start | Programs | IP Office | System Monitor**.
2. Select **File** and then **Select Unit**.
3. Enter the **IP Address** and **Password** of the system that you want to monitor. The values depend on the protocol selected.

Protocol	UDP	TCP	HTTP	HTTPS
<b>Port</b>	-	-	80	443
<b>Username</b>	-	-	Use the same name and password as used for Administrator access for system configuration.	
<b>Password</b>	The <b>System Password</b> or, if set, the specific <b>Monitor Password</b> .			

4. Click **OK**.

---

## 3.7 Starting IP Office Web Manager

Web browser access to the system can be used to run IP Office Web Manager. Enter the system's IP address and then select the **IP Office Web Manager** link. For full details, refer to the IP Office Web Manager Manual.

To use IP Office Web Manager requires the application files to be present on the system's SD card. This is done by selecting the option to include the web manager files when [recreating the SD card](#)<sup>77</sup>.

### To login to a system using IP Office Web Manager:

1. Enter the IP address of the IP Office system. From the menu that appears, click on **IP Office Web Manager**. Alternatively, enter `https://<IP_Address>:8443/WebMgmtEE/WebManagement.html`.
2. The login menu for IP Office Web Manager appears.

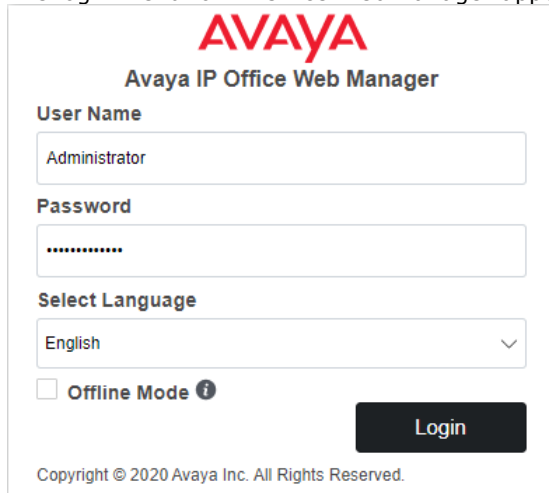

3. Enter the name and password for system administration. The default name and password are both **Administrator**.
  - **Offline Mode** - Some configuration changes can only be applied to a system using a reboot, for example changing line settings. To edit those settings you need to select **Offline Mode**. In that mode, the top of the browser window displays a **Save to IP Office** link which when clicked, displays a menu for the system reboot.
4. Click **Login**.
  - a. You are prompted to change any default password.
  - b. For a new system, the [initial configuration menu](#)<sup>105</sup> appears.

## 3.8 Phone Based Administration

IP Office Essential Edition mode systems do not support phone based administration by default.

Once installed, System Phone rights can be assigned to specific users. For details, refer to the "Administering Avaya IP Office Platform with Manager" manual.

# Chapter 4.

## Preparing the System SD Card

---

## 4. Preparing the System SD Card

New control units are supplied with no installed firmware or configuration. When first powered up, the control unit loads and installs the necessary firmware from the Avaya [System SD](#)<sup>206</sup> card installed in the control unit. It then creates a default configuration matching the physical cards already installed in the control unit and any external expansion modules already attached to it.

You can perform a number of additional actions prior to installing the System SD card in order to pre-configure the system. These can greatly speed up the physical installation at the customer site as they can all be done in advance.

- [Upgrade the Card Firmware](#)<sup>77</sup>
- [Creating an Offline Configuration File](#)<sup>78</sup>
- [Importing and Exporting Settings](#)<sup>79</sup>
- [Adding a Pre-Built Configuration File](#)<sup>80</sup>
- [Adding a License File](#)<sup>80</sup>
- [Adding Security Certificates](#)<sup>80</sup>
- [Adding a 9600 Series Screen Saver File](#)<sup>81</sup>
- [Adding Music on Hold Files](#)<sup>81</sup>

Additional actions that can be performed on SD cards are detailed in the [SD Card Management](#)<sup>138</sup> section.

## 4.1 Upgrade the Card Firmware

You can use IP Office Manager to update the set of files on an System SD card to match those expected for the particular IP Office release. This can be used to upgrade the card from an existing system or to prepare the card for a new system.

IP Office Manager updates the card with the binary firmware files for the control unit, external expansion modules and phones. It also includes the prompt files for embedded voicemail operation and an option for the web manager application files.

Existing files such as the system configuration, PLDS license file and embedded voicemail messages and greetings are retained.

- For the card to be used in an control unit's **System SD** card slot it must be Avaya System SD card. The card must be correctly formatted (that can be done using IP Office Manager), however a reformat of an existing working card is not necessary before using recreate to update the card contents.
- The source for the files copied to the SD card are the sub-folders of the **\Memory Cards** folder under Manager's applications **Working Directory** (normally **C:\Program Files(x86)\Avaya\IP Office\Manager**). However, if the **Working Directory** is changed to a location without an appropriate set of **\Memory Cards** sub-folders, the required set of files will not be copied onto the SD card.

### Setting the Initial System Software Level

When the control unit makes its first call, the version of software it is running is written to a permanent record on the control unit. This becomes the base level of the control unit when considering the future requirements for upgrade. Therefore, for a new system it is important that you upgrade the System SD card to the required software version before starting the system.

### Determining the System SD card software level

On the SD card, in the **system/primary** folder, locate and open the **filelist.txt** file. The header section at the start of the file ends with the version of the set of files previously copied onto the card. The remainder of the file lists the actual files.

### To upgrade/recreate a System SD card

1. Once started do not interrupt this process, for example by removing the SD card. This process takes approximately 20 minutes.
2. Insert the SD card into a card reader on the IP Office Manager PC.
3. Using IP Office Manager, select **File | Advanced | Recreate IP Office SD Card**.
4. Select **IP Office A-Law** or **IP Office U-Law**. This selection affects how the IP Office systems operates when defaulted with this card present in its **System SD** card slot.
5. Browse to the card location and click **OK**.
6. IP Office Manager will prompt whether you want to include Avaya IP Office Web Manager files as part of the recreate process. Those files are necessary if you want to run [IP Office Web Manager](#)<sup>74</sup> to manage the IP Office system into which the card is loaded.
7. IP Office Manager will start creating folders on the SD card and copying the required files into those folders. This process will take approximately 20 minutes.
8. Do not remove the SD card during the process. Wait until the IP Office Manager displays the message "*System SD Card successfully recreated*".

## 4.2 Creating an Offline Configuration File

IP Office Manager can be used to create a new configuration without connecting to an IP Office system. During the process, you can specify the locale of the system, what type of trunk cards it uses and what type of control unit and expansion modules to include.

This allows the creation of a configuration prior to installation of system. The configuration file can then be placed onto the System SD card before it is installed into the system. Otherwise the configuration can be uploaded to the system after initial installation of the system.

- The configuration created must match the physical equipment in the IP Office system onto which it is loaded. Doing otherwise may cause the IP Office system to reset and experience other problems.

### To create an offline configuration file

1. Start IP Office Manager with no configuration loaded into IP Office Manager
2. Select **File | Offline | Create New Config.**

Slot	Extension/VCM	Trunk
1	None	None
2	None	None
3	None	None
4	None	None

3. Select the type of configuration that you want to create. The equipment and settings are restricted to those supported in the selected mode.
4. When completed click **OK**.
5. IP Office Manager creates and loads the configuration.
6. Edit the configuration to match the customer requirements. This can include [importing information from pre-prepared CSV files](#)<sup>79</sup>.
  - Note that since this configuration is being done offline without licensing, you can configure features that may become unsupported once the configuration is loaded into the licensed system.
7. When completed, select **File | Save Configuration As.**
8. When prompted to enter a password to encrypt the file, leave the fields blank and click **OK**.

Slot	Extension/VCM	Trunk
1	None	None
2	None	None
3	None	None
4	None	None

10. You can now rename and copy the file onto the System SD card. See [Adding a Pre-Built Configuration File](#)<sup>80</sup>.

## 4.3 Importing and Exporting Settings

IP Office Manager can import configuration settings created elsewhere. This can be useful when setting up a new system or sharing common settings such as a directory between systems.

- **Comma Separated Variable Text Files (.csv)**

These are plain text files. These files can be created and edited using programs such as WordPad or Excel. The format is CSV using commas as field separator, no text delimiters and no header row. The simplest way to check the required format for a CSV file prior to import, is to export and study the settings from an existing system.

File Name	Fields in Order	Notes
Directory	Name, Number.	–
HuntGroup	Name, Extension, Group, Hunt, Rotary, Idle, Queuing On, Voicemail On, Broadcast, Voicemail Email.	Apart from Name, Extension and Voicemail Email, the fields use a 1 or 0 value for on or off.
License	License, License Key	The License field is for information only and is ignored during import.
ShortCode	Code, Telephone Number, Feature.	–
User	Name, Extension, User Restriction/Rights, Voicemail Email.	
Configuration	The format of this CSV is too complex to be described. It is a full export of all the IP Office system's configuration settings. This file format should only be used for export and import between systems and not for any offline editing.	

- **UTF-8 Character Encoding**

IP Office Manager imports and exports CSV files using UTF-8 character encoding which uses a double byte to support characters with diacritic marks such as ä. Other applications, such as Excel, may, depending on the user PC settings, use different encoding which will cause such characters to be removed or corrupted. Care should be taken to ensure that any tool used to create or edit the CSV supports all the characters expected and uses UTF-8 format.

- **Importing into Manager from Excel**

From Excel save the file as a .csv. This file will use ANSI character encoding. Open the file in Notepad and use the **Save As** option to rename the file and select UTF-8 encoding. Import the UTF-8 version of the file into IP Office Manager.

- **Exporting from IP Office Manager into Excel**

Do not double-click on the file exported from IP Office Manager. Start Excel and use **File | Open** to select the file. Excel will recognize that the file uses UTF-8 encoding and will start its text file importation wizard. Follow the wizard instructions and select comma as the field delimiter.

### Exporting Settings

1. Within IP Office Manager, load the IP Office configuration. Select **File | Import/Export...**
2. Select **Export**.
3. Select the type of file. The list of exportable entry types will change to match the file type.
4. Select the types of items that should be exported.
5. Use the **Save In** path to select the location for the exported files. The default location used is sub-directory of the IP Office Manager application directory based on system name of the currently loaded IP Office system.
6. Click **OK**.

### Importing Settings

Importing settings will overwrite any existing entries that match an entry being imported.

1. Within IP Office Manager, select **File | Import/Export...** from the menu bar.
2. Select **Import**.
3. Select the type of file. The list of items will change to match the type of file selected and whether a matching file or files is found in the current file path.
4. Use **Look In** to adjust the file path.
5. Select the types of items that should be imported.
6. Click **OK**.

---

## 4.4 Adding a Pre-Built Configuration File

IP Office Manager can be used to [create an offline configuration file](#)<sup>78</sup>. That file can then be edited and placed on a system's System SD card prior to its installation. That file is then loaded when the new system is started.

- The configuration created must match the physical equipment in the IP Office system onto which it is loaded. Doing otherwise may cause the IP Office system to reset and experience other problems.

### To load a pre-built offline configuration onto a System SD card

1. Using IP Office, create an offline configuration that matches the customer requirements and the equipment that will be installed in the IP Office.
2. Rename the configuration file **config.cfg**.
3. Using a card reader, copy the file into the **/system/primary** folder on the System SD memory card.

## 4.5 Adding a License File

The XML file containing the systems PLDS licenses is stored on the System SD card. This file can be added to the system SD card prior to installation. The license are then automatically imported into the system configuration when the system is started.

- The card's ID number is printed on the card's label after **PLDS ID**, **FK SN** or **FK** depending on the age of the card. On newer cards is a 12-digit number. Older cards may have a 10-digit number. For PLDS licensing, use the 12-digit number. On older cards, for licensing, prefix the 10-digit number with **11**.

### Minimum License Requirements

For IP Office Essential Edition, the system requires an **Essential Edition** system license for the specific IP Office release you want it to run.

### To load a License File onto a system SD card

1. Rename the supplied .XML license file to **PLDSkeys.xml**.
2. Using a card reader, copy the file into the **/system/primary** folder on the System SD memory card.

## 4.6 Adding Security Certificates

The IP Office system can use security certificates to validate the connections between itself, applications and other IP Office systems. Certificates can also be used for IP telephony communications.

Certificates can be placed onto the System SD card. Those certificates are then loaded into the system's certificate store when the system is started. The certificate file name extension must indicate the type of encoding; PEM encoded files should end with **.pem**, DER encoded files should end with **.der**.

### To load a certificate to add:

1. Using a card reader, copy the file into the **/system/primary/certificates/tcs/add** folder on the System SD memory card.

### To load a certificate to remove:

The mechanism above can adapted to also remove an existing certificate.

1. Using a card reader, copy the file into the **/system/primary/certificates/tcs/remove** folder on the System SD memory card. If the matching certificate already exists in the system certificate store, that certificate is removed.

## 4.7 Adding a 9600 Series Screen Saver File

When idle, 9600 Series phones can timeout to displaying a screen saver image. Various **.jpg** files are present in the cards **/system/primary** folder by default.

You can replace these files with your own branded files. The files should be smaller than the screen size on 9600 Series phones in order to then be moved around the screen.

Phone	Maximum Size	Phone	Maximum Size	Phone	Maximum Size
9611	160x160	9621G	320x160	9641G	320x240

- Color Displays: Color depth is 16 bit.
- Non-Color Displays: Best results are achieved with a single grayscale logo image. 2 levels of grayscale are also supported.
- To invoke transparent backgrounds with logos, use a background color of 0,255,0 (brightest possible green).

## 4.8 Adding Music on Hold Files

By default the IP Office will use internal music on hold by uploading a music file to the system. For IP500 V2 systems, you can load a file onto the System SD card prior to installing it in the IP Office.

The file must be of the following format and must be called **holdmusic.wav**.

Property	Value	Property	Value
File Type	WAV	Audio Sample Rate	8kHz
Bit Rate	128kbps	Audio Format	PCM
Audio sample size	16 bit	Length	Up to 90 seconds.
Channels	1 (mono)		

### To loading a music on hold file onto a System SD card

1. Rename the music file **holdmusic.wav**.
2. Using a card reader, copy the file into the **/system/primary** folder on the System SD memory card.
3. If the IP Office is or will be configured for additional hold music files (up to 3 additional files), copy those files to the same location. The name of the additional files must match those specified in the IP Office system's configuration.



# Chapter 5.

## Installing the Control Unit Cards

## 5. Installing the Control Unit Cards

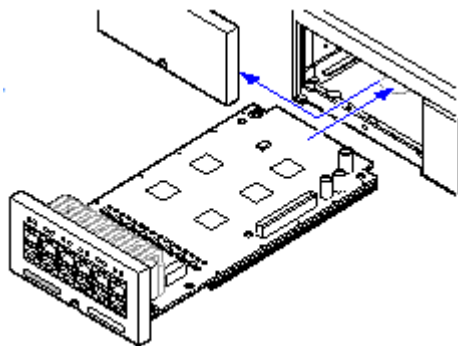

The IP500 base cards and trunk daughter cards should be fitted before power is applied to the control unit. Ensure that cards are inserted in the order that matches the planned or pre-built configuration.

This process has 2 stages:

1. [Fit the IP500 trunk daughter cards onto the IP500 base cards.](#)<sup>85</sup>
2. [Insert the IP500 Base Cards into the Control Unit.](#)<sup>86</sup>

### Warning

- Correct anti-static protection steps should be taken before handling circuit boards.
- **! IMPORTANT: You Must Switch Off the Control Unit Before Adding, Removing or Swapping Components**  
Base cards, trunk cards and external expansions modules must only be removed and added to an IP Office system when that system is [switched off](#)<sup>161</sup>. Failure to do so will result in the new component not loading the correct firmware and not operating or not operating correctly. This applies even when swapping like for like components.

### General Notes

- Cards can be fitted in any order into any available slots. The only exception is the IP500 4-Port Expansion card which can only be installed in right hand slot 4.
- It is recommended that cards are fitted from left to right.
- There are restrictions to the number of supported cards of some types. When such a limit is exceed, the right-most card of that type will not function.
- Ensure that you use the labels supplied to identify the card fitted into the control unit.

## 5.1 Fitting IP500 Daughter Cards

IP500 trunk daughter cards can be fitted to any IP500 base card except the 4-Port Expansion card. For IP500 Combination cards, the trunk daughter card is pre-installed and cannot be changed.

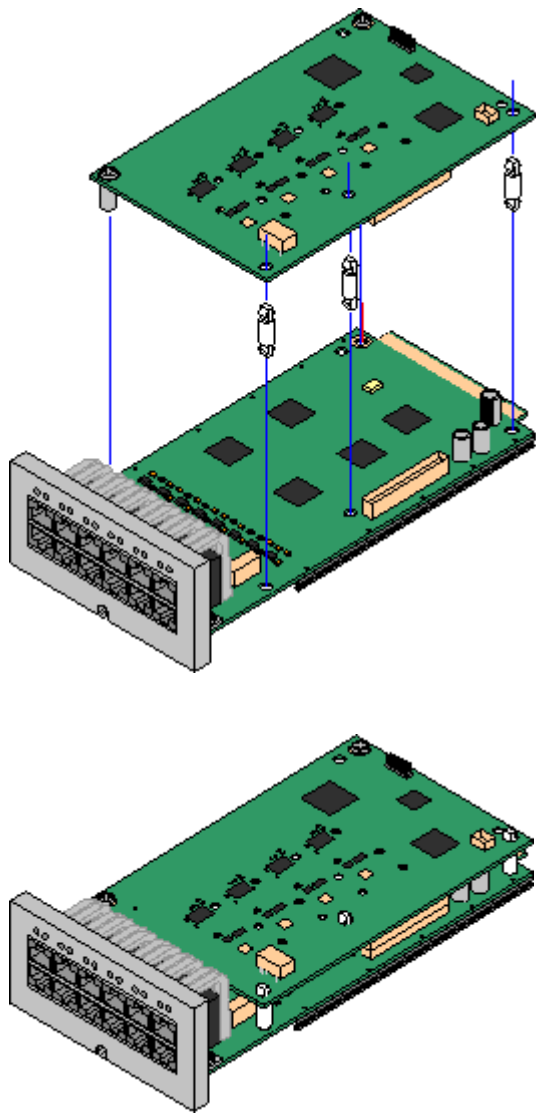

### ⚠ Warning

- Correct anti-static protection steps should be taken while handling circuit boards.

### Parts and Equipment Required

1.  **IP500 Base Card**
2.  **IP500 Trunk Daughter Card**
3.  **3 Stand Off Pillars**  
These are supplied with the trunk daughter card.

### Tools Required

1.  5mm Flat-blade screwdriver.
2.  Anti-static wrist strap and ground point.

### Procedure: Installing a Trunk Daughter Card

1. Check that correct cards have been supplied.
2. Ensure that you are wearing an anti-static wrist strap connected to a suitable ground point.
3. On the base card identify the position of 3 holes for the plastic pillars for the IP500 card. These are along the same edge as the card connector.
4. Fit the stand off pillars to the IP500 base card.
5. If there is a clip-on metal shield over the connector block on the base card, remove it.
6. Using minimal force and checking that the pins are correctly located, push the IP500 trunk card onto its connector block and the stand off pillars.
7. Check that the card connector has snapped into position.
8. Using the washers and screws provided, secure the metal stand off pillars to the base card.
9. A set of labels are supplied with the trunk daughter card. Fit the appropriate label to the front of the base card.

## 5.2 Inserting IP500 Base Cards

Having prepared each IP500 base card by adding any [trunk daughter card](#)<sup>185</sup>, the base card can be inserted into the control unit.

### Warnings

- Correct anti-static protection steps should be taken while handling circuit boards.
- **! IMPORTANT: You Must Switch Off the Control Unit Before Adding, Removing or Swapping Components**  
Base cards, trunk cards and external expansions modules must only be removed and added to an IP Office system when that system is [switched off](#)<sup>161</sup>. Failure to do so will result in the new component not loading the correct firmware and not operating or not operating correctly. This applies even when swapping like for like components.

### Tools Required

- □ 5mm Flat-blade screwdriver.
- □ Anti-static wrist strap and ground point.

### Installing an IP500 Card

1. Check that there is no power to the control unit.
2. Using a flat-bladed screwdriver, remove the cover from the slot on the front of the control unit that will be used for each card being installed. This cover is no longer required but should be retained until installation has been completed.

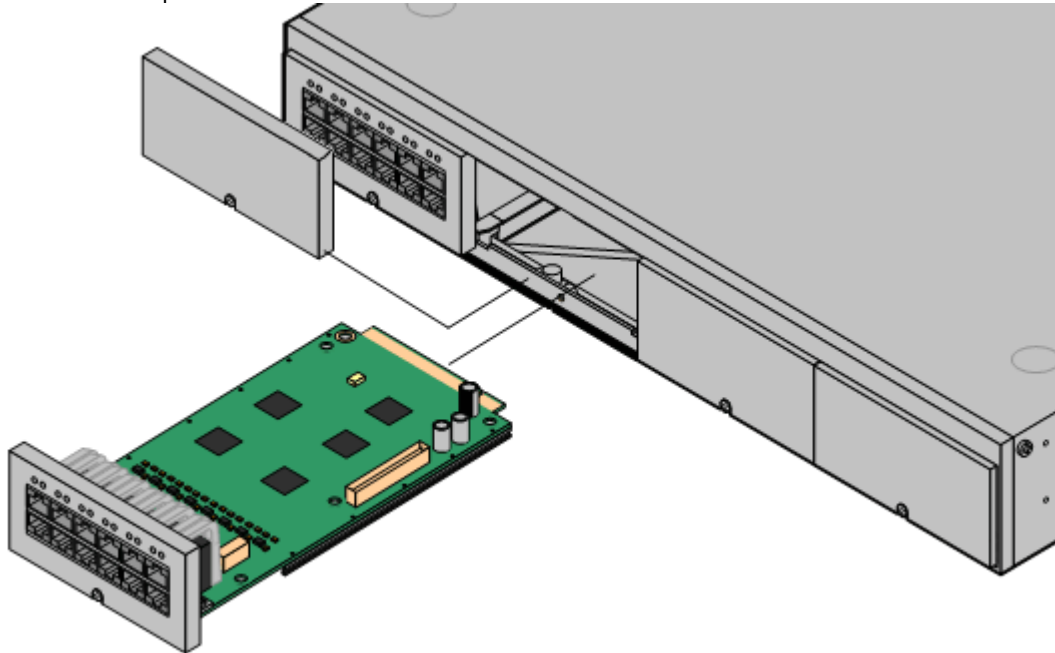

3. Allowing the card to rest against the bottom of the slot, begin sliding it into the control unit. When half inserted, check that the card rails have engaged with the slot edges by trying to gently rotate it. If the card rotates remove it and begin inserting it again.
4. The card should slide in freely until almost fully inserted. At this point apply pressure at the base of the front of the card to complete insertion.
5. Using a flat-bladed screwdriver secure the card.

# Chapter 6.

# Installing the Physical System

---

## 6. Installing the Physical System

Having prepared for installation, this section covers the basic on-site installation.

### Summary

#### 1. System SD Card Licensing

- a. Obtain an IP Office System SD card.
- b. Using the card's PLDS ID number, obtain a license file for the required release of IP Office software. The file needs to include an IP Office Essential Edition license plus licenses for any other features required.

#### 2. Prepare for installation [□](#)<sup>50</sup>

- a. [Environmental Requirements](#) [□](#)<sup>51</sup>  
Check that the installation area meets the system environmental requirements.
- b. [Space Requirements](#) [□](#)<sup>53</sup>  
Check that the installation area meets the system space requirements.
- c. [Tools and Parts Required](#) [□](#)<sup>61</sup>  
Check that you have the tools and additional parts required.
- d. [Documentation](#) [□](#)<sup>62</sup>  
Ensure that you have obtained and read all the relevant documentation.
- e. [Unpacking](#) [□](#)<sup>63</sup>  
Check that all the required equipment has been delivered and that there is no damage.

#### 3. Admin Software Installation [□](#)<sup>66</sup>

For system installation you need a PC with the IP Office administrator software installed. This must include a copy of IP Office Manager that matches the IP Office software level required.

- a. [Downloading the Software](#) [□](#)<sup>67</sup>
- b. [Installing the Administrator Applications](#) [□](#)<sup>68</sup>

#### 3. Preparing the System SD card [□](#)<sup>76</sup>

Upgrade the System SD card to the required release of IP Office software.

#### 4. Install the control unit cards [□](#)<sup>84</sup>

Attach any trunk daughter cards to their IP500 base cards and insert the base cards into the control unit.

#### 5. Install the system [□](#)<sup>88</sup>

- a. [Wall Mounting](#) [□](#)<sup>89</sup>  
If wall mounting, attach the brackets and fit the unit to the wall.
- b. [Rack Mounting](#) [□](#)<sup>91</sup>  
If rack mounting, attach the brackets and fit the control unit into the rack.
- c. [Connect the External Expansion Modules](#) [□](#)<sup>93</sup>  
Connect the external expansions modules to the control unit.
- d. [Ground the system](#) [□](#)<sup>95</sup>  
Attach required ground cables to the control unit and external expansion modules.
- e. [Starting the System](#) [□](#)<sup>96</sup>  
Insert the System SD card and power up the system.
- f. [Connecting Phones](#) [□](#)<sup>99</sup>  
Connect the Avaya digital phones.

#### 6. Initial Configuration

Once the physical system is started, it can be configured. This can be done using either [IP Office Manager](#) [□](#)<sup>102</sup> or [IP Office Web Manager](#) [□](#)<sup>114</sup>.

## 6.1 Wall Mounting

IP500 V2 control units and IP500 external expansion modules can be wall or rack mounted. To do this, a wall mounting kit is required in addition to suitable wall fixings.

In addition to the existing [environmental requirements](#)<sup>51</sup> for an IP Office system, the following additional requirements apply when wall mounting a unit:

- The wall surface must be vertical, flat and vibration free. Attachment to temporary walls is not supported.
- Only the screws provided with the mounting kit should be used to attach the brackets to the control unit or expansion modules.
- The installation must be done by a service person.
- Ensure that the system has been shut down and power has been removed from all the units. Shut down the system using a shutdown command and then remove the power. Do not simply remove the power.
- A suitable plywood mounting surface of at least 1m x 1m x 19mm (39" x 39" x 0.75") is required. If an expansion box is being mounted as well a plywood mounting surface of at least 1.2m x 1.2m x 19mm (48" x 48" x 0.75") is required.
- A minimum of 6 x 45mm long 5mm/6mm ( 1.75" #10/#12) pan head screws must be used to secure the plywood to the wall studs.
- The supplied 20mm long 4mm (#8 3/4") wood screws must be used to secure the brackets to the plywood mounting surface

The following kit is currently available:

- **IPO IP500 WALL MNTG KIT V3** (SAP Code 700503160)  
This kit can be used for [wall and rack mounting](#) of IP500 V2 control units and IP500 external expansion modules. The kit incorporates cable routing at the front and rear of the unit. For wall mounted control units, it allows orientation of the control unit base card slots to the left or to the right.

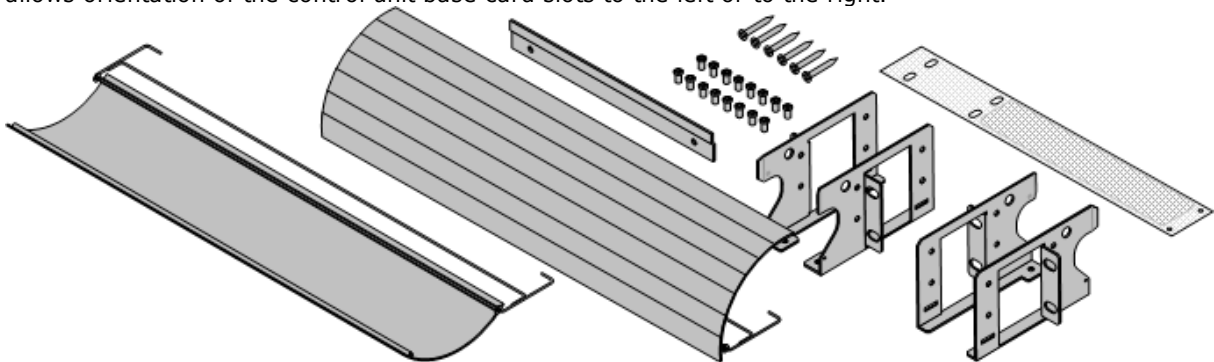

### 6.1.1 Wall Mounting Kit V3

These notes relate to the **IPO IP500 WALL MNTG KIT V3** (SAP 700503160). This kit can be used to wall or rack mount IP500 V2 control units and IP500 external expansion modules.

The kits includes all components necessary for wall mounting onto a plywood surface. The use of the cable covers is optional.

In addition to the existing [environmental requirements](#)<sup>D51</sup> for an IP Office system, the following additional requirements apply when wall mounting a unit:

- The wall surface must be vertical, flat and vibration free. Attachment to temporary walls is not supported.
- Only the screws provided with the mounting kit should be used to attach the brackets to the control unit or expansion modules.
- The installation must be done by a service person.
- Ensure that the system has been shut down and power has been removed from all the units. Shut down the system using a shutdown command and then remove the power. Do not simply remove the power.
- A suitable plywood mounting surface of at least 1m x 1m x 19mm (39" x 39" x 0.75") is required. If an expansion box is being mounted as well a plywood mounting surface of at least 1.2m x 1.2m x 19mm (48" x 48" x 0.75") is required.
- A minimum of 6 x 45mm long 5mm/6mm ( 1.75" #10/#12) pan head screws must be used to secure the plywood to the wall studs.
- The supplied 20mm long 4mm (#8 3/4") wood screws must be used to secure the brackets to the plywood mounting surface
- The installation must be done by a service person only.
- For control units, the mesh flame screen must be installed on the bottom edge of the control unit before mounting. The flame screen attaches to the outside of the control unit.
- Ensure that the system has been shutdown and power has been removed from all the units. Shutdown the system using a shutdown command and then remove power. Do not simply remove the power.
- Full installation instructions are included with the kit.

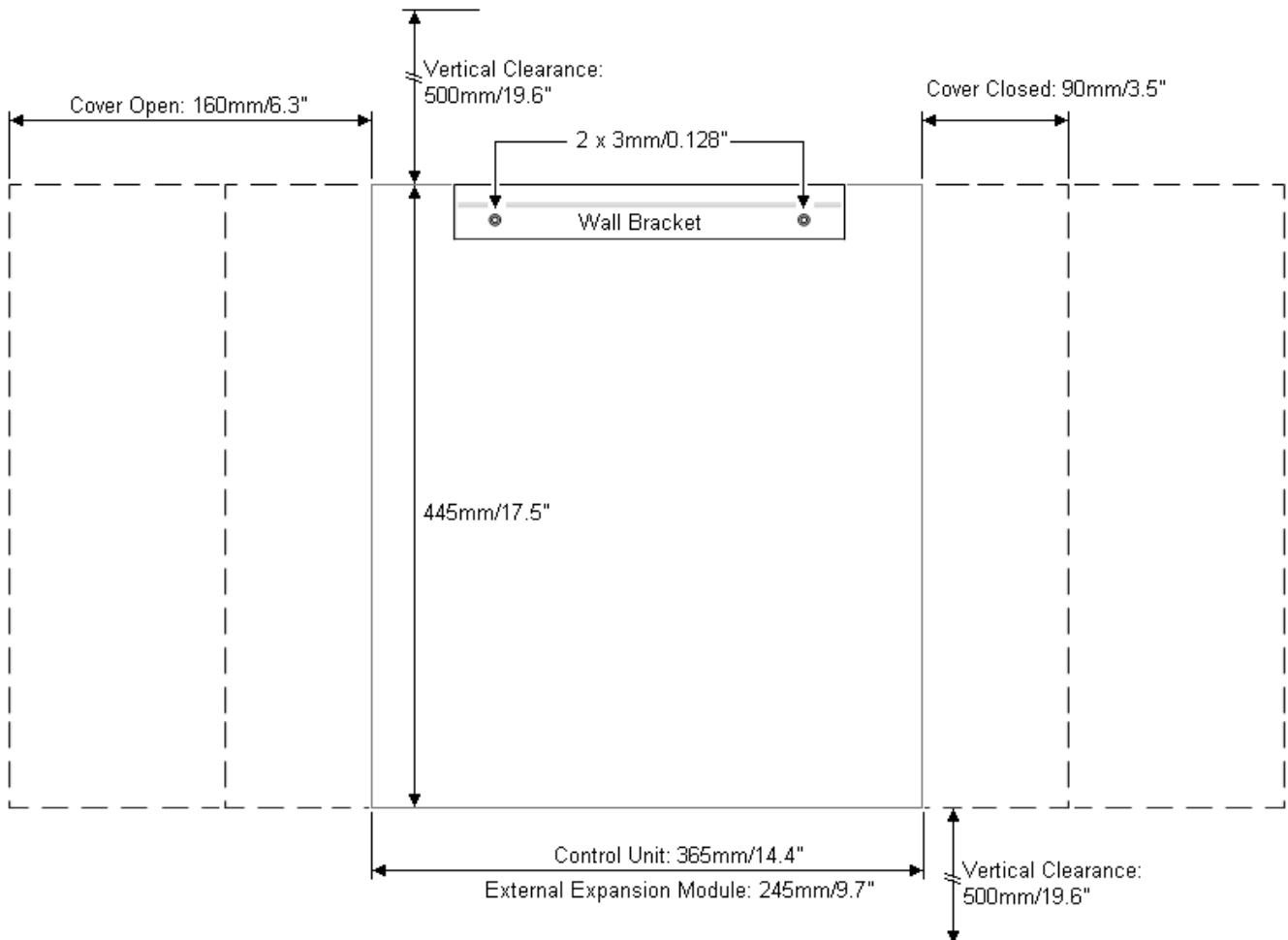

## 6.2 Rack Mounting

All IP Office control units and external expansion modules can be rack mounted into standard 19" rack systems. Each unit requires a 2U slot space within the rack. Rack mounting requires a kit for each control unit and external expansion module.

Where systems are being rack mounted, the effect of conditions within the rack cabinet must be considered. For example, the rack temperature may be above the room temperature and airflow within the rack is restricted. The [environmental requirements](#)<sup>35</sup> for the individual IP Office units are still applicable inside the rack cabinet.

- **IPO IP500 WALL MNTG KIT V3** (SAP Code 700503160)

This kit can be used for [wall and rack mounting](#) of IP500 V2 control units and IP500 external expansion modules. The kit incorporates cable routing at the front and rear of the unit. For wall mounted control units, it allows orientation of the control unit base card slots to the left or to the right.

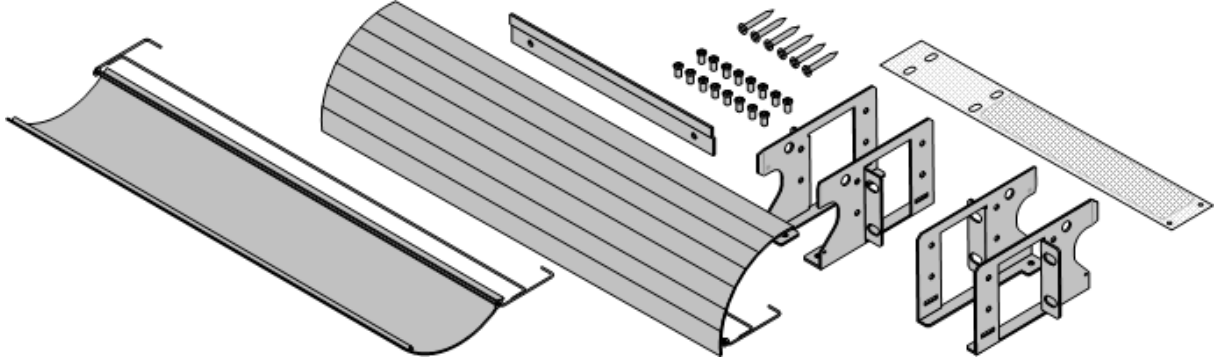

- **IPO IP500 RACK MNTG KIT** (SAP Code 700429202)

This kit contains all the components required for the rack mounting of a single IP500 V2 control unit or IP500 external expansion module. This includes screws for fixing of the brackets to the module, bolts for securing the module in the rack and cable tidy brackets..

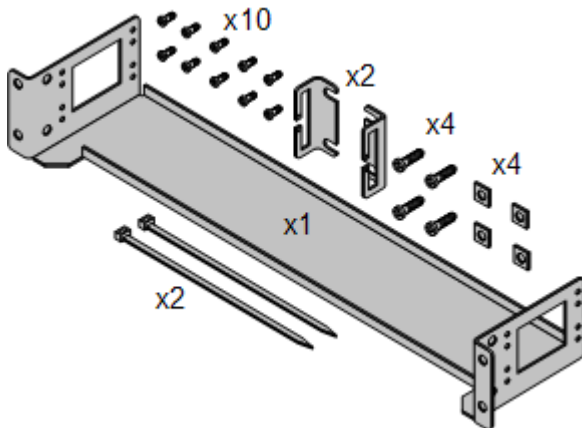

### Barrier Box Rack Mounting Kit

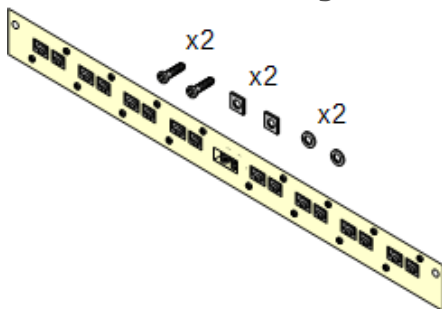

- **Barrier Box Rack Mounting Kit** (SAP 700293905)

Barrier boxes must be used for [out-of-building analog phone extensions](#)<sup>36</sup>. This bracket allows up to 8 IP Office barrier boxes to be rack mounted and simplifies the number of connections to the protective ground point in the rack. This kit must be used when more than 3 barrier boxes are in use and supports a maximum of 16 barrier boxes for a single external expansion module.

---

## Environmental Requirements

In addition to the existing [environmental requirements](#)<sup>51</sup> for an IP Office system, the following additional factors must be considered when rack mounting a unit:

1. Rack Positioning - Ensure compliance with the rack manufacturers safety instructions. For example check that the rack legs have been lowered and fixing brackets have been used to stop toppling.
2. Elevated Operating Ambient - If installed in a closed or multi-unit rack assembly, the operating ambient temperature of the rack environment may be greater than room ambient. Therefore, consideration should be given to installing the equipment in an environment compatible with the maximum ambient temperature (T<sub>ma</sub>) specified by the manufacturer.
  - Operating Temperature: 5°C (40°F) to 40°C (104°F).
  - Operating Humidity: 10% to 95% non-condensing.
3. Reduced Air Flow - Installation of the equipment in a rack should be such that the amount of air flow required for safe operation of the equipment is not compromised. Proper ventilation must be maintained. The side ventilation slots on the IP500 control unit should not be covered or blocked.
4. Mechanical Loading - Mounting of the equipment in the rack should be such that a hazardous condition is not achieved due to uneven mechanical loading.
5. Circuit Overloading - Consideration should be given to the connection of the equipment to the supply circuit and the effect that overloading of the circuits might have on overcurrent protection and supply wiring. Appropriate consideration of equipment nameplate ratings should be used when addressing this concern.
6. Reliable Earthing - Reliable earthing of rack-mounted equipment should be maintained. Particular attention should be given to supply connections other than direct connections to the branch circuit (e.g. use of power strips).
7.  Only the screws provided with the mounting kit should be used to attach the brackets to the control unit.

## 6.3 Connecting External Expansion Modules

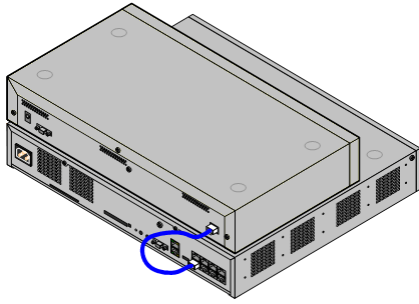

Any external expansion modules should be connected to the control unit before power is applied to the control unit. Ensure that modules are attached in the order that matches the planned or pre-built configuration.

External expansion modules connect to the IP Office control unit using an expansion interconnect cable. Each module is supplied with an expansion connect cable and a [power supply unit](#)<sup>30</sup>. An appropriate [locale specific power cord](#)<sup>31</sup> for the power supply unit must be ordered separately.

- Each external expansion module is supplied with a blue 1 meter (3'3") expansion interconnect cable. This cable **must** be used when connecting to expansion ports on the rear of a control unit.
- When connecting to expansion ports on an IP500 4-Port Expansion card, a supplied yellow 2 meter (6'6") expansion interconnect cable can be used in place of the supplied blue cable. 4 Yellow cables are supplied with the IP500 4-Port Expansion card.
- **! IMPORTANT: You Must Switch Off the Control Unit Before Adding, Removing or Swapping Components**  
Base cards, trunk cards and external expansions modules must only be removed and added to an IP Office system when that system is [switched off](#)<sup>161</sup>. Failure to do so will result in the new component not loading the correct firmware and not operating or not operating correctly. This applies even when swapping like for like components.

### Installation Requirements

- Installation space either on or under the existing IP Office control unit. See [Rack Space Requirements](#)<sup>59</sup> for the positioning of multiple stacked modules.
- Switched power outlet socket.  
The power outlet used must include a switch and in cases where the [power cord](#)<sup>31</sup> includes an earth lead, that outlet must have a protective earth connection.
- **! Important: External Expansion Module Power**  
In order to be detected and operated correctly, external expansion modules must start before the IP Office control unit. Normally this achieved by connected all expansion modules to the same power strip as the control unit. The control unit applies a short delay to its own start-up process to ensure that expansion modules powered on at the same time as it are detected.
- Available EXPANSION port on the control unit.
- Grounding Requirements
  - **Functional Grounding**  
Connection of a [functional earth](#)<sup>35</sup> is:
    - Recommend for all modules.
    - Connection of a functional ground is mandatory for Analog Trunk modules.
  - **Protective Grounding**  
Connections of a protective ground via [surge protection equipment](#)<sup>36</sup> is:
    - Mandatory for Analog trunk modules in the Republic of South Africa.
    - Mandatory for Digital Station and Phone modules connected to out of building extensions.
    - Mandatory for Digital Station V2 and Phone V2 modules.

### Tools Required

- IP Office Manager PC.
- [Tools for rack mounting](#)<sup>91</sup> (optional).

### Parts and Equipment Required

- **External Expansion Module.**  
Each module is supplied with a suitable external power supply unit and a 1m blue interconnect cable. 2m Yellow interconnect cables are supplied with the IP500 4-Port Expansion card and should only be used with that card.
- [Power cord for the power supply unit](#)<sup>31</sup>.
- [Rack mounting kit](#)<sup>37</sup> (optional).
- [Wall mounting kit](#)<sup>89</sup> (optional - IP500 external expansion modules only).
- Cable labeling tags.

---

## Procedure

1. External expansion modules should not be attached to a control unit that has power. If adding a new module to an existing system, [shutdown the system](#)<sup>161</sup>.
2. If the IP Office system is being installed in a rack, attach the [rack mounting kit](#)<sup>91</sup> to the expansion module.
3. Attach the external expansion module's power supply but do not switch power on.
4. Connect the expansion interconnect cable from the module's EXPANSION port to the EXPANSION port on the control unit.

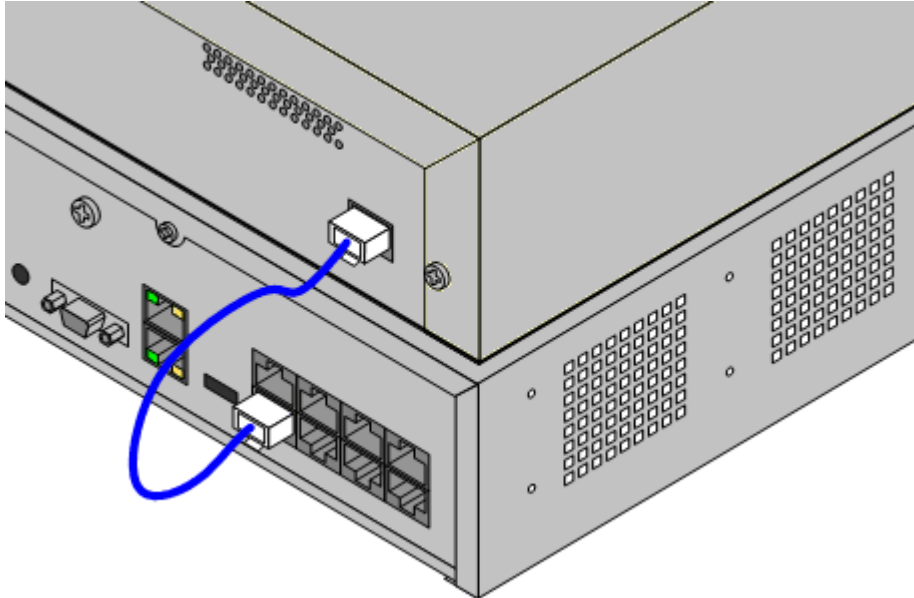

- **Note**

It is recommended to connect modules from port 1 upwards, using each port in sequence.

5. Make careful note of the port used and include this detail on the cable label and any other system records.
6. Attach any other external expansion modules being added.
7. You can now [attach the grounding cabling](#)<sup>95</sup> for the external expansion modules.
  - a. Once the expansion modules are connected and grounded you can [start the system](#)<sup>96</sup>. Ensure that the external expansion module's are started before the control unit.

## 6.4 Grounding

Use of ground connections reduces the likelihood of problems in most telephony and data systems. This is especially important in buildings where multiple items of equipment are interconnected using long cable runs, for example phone and data networks.

All IP Office control units and external expansion modules must be connected to a functional ground. Where the unit is connected to a power outlet using a power cord with an earth lead, the power outlet must be connected to a protective earth.

In some cases, such as ground start trunks, in addition to being a protective measure this is a functional requirement for the equipment to operate. In other cases it may be a locale regulatory requirement and or a necessary protective step, for example areas of high lightning risk.



- **⚠ WARNING**  
During installation do not assume that ground points are correctly connected to ground. Test ground points before relying on them to ground connected equipment.
- **Additional protective equipment**  
In addition to grounding, additional protective equipment will be required in the following situations.
  - On any Digital Station or Phones external expansion module connected to an extension located in another building. Refer to "[Out of Building Telephone Installations](#)"<sup>36</sup>.
  - In the Republic of South Africa, on all Analog Trunk external expansion modules (ATM16) and on any control units containing an analog trunk cards (ATM4/ATM4U).

### Tools Required

- □ M4 Cross-Head Screwdriver.
- □ Tools suitable for crimping a cable spade.

### Parts and Equipment Required

- □ 14AWG Solid copper wire for ground connection.
- □ Cable sleeve matching local regulator requirements. Typically green for a functional ground and green/yellow for a protective ground.

The ground point on IP Office control units and expansion modules are marked with a  or  symbol. Ground connections to these points should use a 14 AWG solid wire with either a green sleeve for a functional ground or green and yellow sleeve for a protective ground.

### IP500 V2 Control Unit

On IP500 V2 control units the ground point is located above the RS232 DTE port.

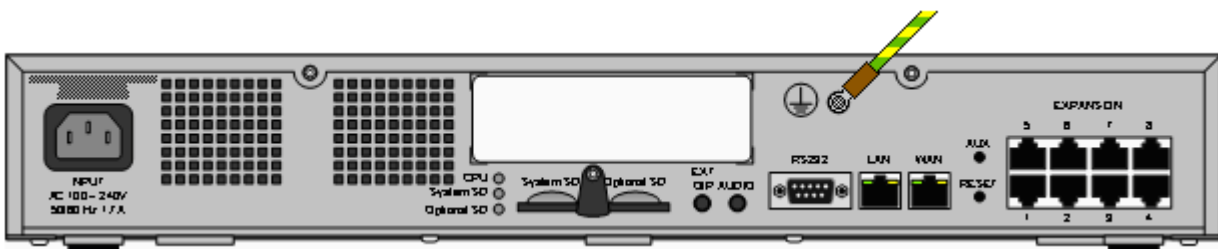

### External Expansion Modules

On expansion modules, the ground point is a 4mm screw located towards the right on the rear of the module.

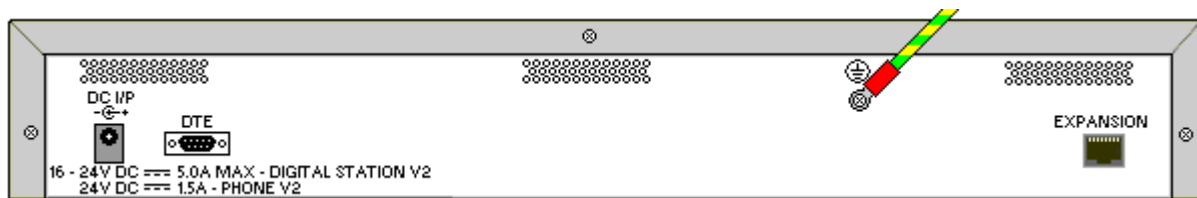

- On some older modules, the dedicated ground point screw is not present. In those cases, the top-center cover fixing screw (3mm) can be used as an alternative ground connection point. A toothed washer should be added to ensure good contact.

---

## 6.5 Starting the System

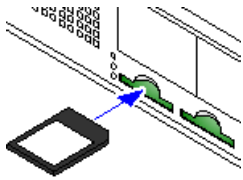

Before inserting the System SD card and starting the system, check the following:

- a. Ensure that you have the correct type of [Avaya System SD card](#)<sup>206</sup>.
- b. Check that the ID number printed on the card matches the number against which licenses have been issued.
- c. Ensure that the card has the required level of software. If necessary, [upgrade the card using IP Office Manager](#)<sup>77</sup>.

### Inserting the System SD card:

1. With the control unit shut down:
  - i. The SD card slots are covered by a plastic tab. Partially release the screw holding the tab so that it can be moved clear of the **System SD** card slot.
  - ii. Insert the card into the slot labeled **System SD**.
2. Apply power to any external expansion modules.
  - **! Important: External Expansion Module Power**  
In order to be detected and operated correctly, external expansion modules must start before the IP Office control unit. Normally this achieved by connected all expansion modules to the same power strip as the control unit. The control unit applies a short delay to its own start-up process to ensure that expansion modules powered on at the same time as it are detected.
3. Apply power to the control unit. The power outlet used must include a switch and the power outlet must have a protective earth connection.
4. The control unit loads firmware from the System SD card with which it upgrades itself and its internal components.
5. The LED's on any base card in the system will go through a sequence of being solid red for a minute, then flashing red for 2 minutes. This sequence will then repeat. In total this process takes approximately 6 minutes (future restarts not involving any software update take approximately 2 minutes).
6. The end of this process is indicated by LED1 on each base card flashing every orange every 5 seconds. This is the systems normal healthy heartbeat indication. On base cards with a trunk daughter card fitted, LED9 also flashes every 5 seconds.
7. The control unit then begins upgrading the external expansion modules if necessary. This is indicated by the center LED on the module flashing red. This process is completed when the LED changes to steady green.
8. If a configuration file is already [present on the System SD](#)<sup>80</sup> card it is loaded by the IP Office. If not, new systems create a default configuration and copy that configuration onto the System SD card.

## 6.6 Checking the LEDs

The LED's shown on an operating system are summarized below.

### Control Unit LEDs

LED	Description
Optional SD	<ul style="list-style-type: none"> <li>• <b>Off</b> = Card shutdown.</li> <li>• <b>Green on</b> = Card present.</li> </ul>
System SD	<ul style="list-style-type: none"> <li>• <b>Green flashing</b> = Card in use.</li> <li>• <b>Orange steady</b> = Reset imminent.</li> <li>• <b>Red flashing</b> = Card initializing or shutting down.</li> <li>• <b>Red fast flashing</b> = card full</li> <li>• <b>Red steady</b> = Card failure/wrong type.</li> </ul>
CPU	<ul style="list-style-type: none"> <li>• <b>Alternate red/green</b> = Starting up.</li> <li>• <b>Green on</b> = Okay.</li> <li>• <b>Red on</b> = No software.</li> <li>• <b>Flashing Red</b> = Error/Shutdown.</li> </ul>

### Base Card LEDs

Note: Cards not supported by the system's particular mode, locale or level of software will display a solid red LED.

Base Card	LEDs 1 to 8 Usage												
All Cards	<ul style="list-style-type: none"> <li>• LED1 is also used for base card status:                             <ul style="list-style-type: none"> <li>• <b>Red On</b> = Error/Not supported.</li> <li>• <b>Red Slow Flash</b> = Initializing.</li> <li>• <b>Red Flash every 5 seconds</b> = Card okay.</li> <li>• <b>Red Fast Flash</b> = System shutdown.</li> </ul> </li> </ul>												
IP500 Analog Phone	<ul style="list-style-type: none"> <li>• No status LEDs are used for analog phone extensions.</li> </ul>												
IP500 Digital Station	<ul style="list-style-type: none"> <li>• <b>Green Flashing</b> = Phone detected.</li> <li>• <b>Green On</b> = Phone active.</li> </ul>												
IP500 Combination	<ul style="list-style-type: none"> <li>• LEDs 1 to 6                             <ul style="list-style-type: none"> <li>• <b>Green Flashing</b> = Phone detected.</li> <li>• <b>Green On</b> = Phone active.</li> </ul> </li> </ul>												
IP500 VCM	<ul style="list-style-type: none"> <li>• LEDs 1 to 8 are unlabelled. They are used to indicate voice compression channel usage. Each LED represents 12.5% of available voice compression channel capacity.</li> </ul>												
IP500 4-Port Expansion	<ul style="list-style-type: none"> <li>• LEDs 1 to 8 are used for the expansion ports on the rear of the control unit. LEDs 9 to 12 are used for the card's own expansion ports.                             <table border="1" style="margin-left: 20px;"> <tbody> <tr> <td><b>Green</b></td> <td><b>On</b></td> <td>Expansion module present.</td> </tr> <tr> <td><b>Red</b></td> <td><b>Flashing</b></td> <td>Initializing.</td> </tr> <tr> <td><b>Red</b></td> <td><b>On</b></td> <td>Error.</td> </tr> <tr> <td><b>Orange</b></td> <td><b>Regular Flash</b></td> <td>Base card okay.</td> </tr> </tbody> </table> </li> </ul>	<b>Green</b>	<b>On</b>	Expansion module present.	<b>Red</b>	<b>Flashing</b>	Initializing.	<b>Red</b>	<b>On</b>	Error.	<b>Orange</b>	<b>Regular Flash</b>	Base card okay.
<b>Green</b>	<b>On</b>	Expansion module present.											
<b>Red</b>	<b>Flashing</b>	Initializing.											
<b>Red</b>	<b>On</b>	Error.											
<b>Orange</b>	<b>Regular Flash</b>	Base card okay.											

## Trunk Daughter Card LEDs

Trunk Daughter Card	LEDs 9 to 12 Usage
All cards	<ul style="list-style-type: none"> <li>LED 9 is also used for daughter card status. <ul style="list-style-type: none"> <li><b>Red On</b> = Error</li> <li><b>Red Slow Flash</b> = Initializing.</li> <li><b>Red Flash every 5 seconds</b> = Card okay.</li> <li><b>Red Fast Flash</b> = System shutdown.</li> </ul> </li> </ul>
Analog Trunk	<ul style="list-style-type: none"> <li><b>Green on</b> = Line connected to the port but idle.</li> <li><b>Green flashing</b> = Line in use.</li> </ul>
PRI Trunk	<ul style="list-style-type: none"> <li><b>Off</b> = No trunk present.</li> <li><b>Green on</b> = Trunk present.</li> <li><b>Green flashing</b> = Trunk in use.</li> <li><b>Red/Green Fast Flash</b> (port 9) or <b>Green Fast Flash</b> (port 10) = Alarm indication signal (AIS) from the trunk remote end.</li> <li><b>Red with Green Blink</b> (port 9) or <b>Green Blink</b> (port 10) = Port in loopback mode (set through IP Office System Monitor).</li> </ul>
BRI Trunk	<ul style="list-style-type: none"> <li><b>Off</b> = No trunk present.</li> <li><b>Green on</b> = Trunk present.</li> <li><b>Green flashing</b> = Trunk in use.</li> </ul>

## External Expansion Module LEDs

Module	LEDs
All	<p>The center LED on all external expansion modules is used to indicate the overall state of the module as follows:</p> <ul style="list-style-type: none"> <li><b>Red flashing</b> = Module starting up/Loading firmware.</li> <li><b>Red on</b> = Error.</li> <li><b>Green on</b> = Module okay.</li> <li><b>Green flashing</b> = Module starting up/Loading firmware (IP500 DS16A/30A module only).</li> </ul>
Analog Trunk 16	<ul style="list-style-type: none"> <li>None.</li> </ul>
BRI So8	<ul style="list-style-type: none"> <li><b>Green On</b> = Connected.</li> <li><b>Green Flashing</b> = Activity.</li> </ul>
Digital Station 16/30	<ul style="list-style-type: none"> <li><b>Green Flashing</b> = Phone detected.</li> <li><b>Green On</b> = Phone active.</li> </ul>
Digital Station 16A/30A	<ul style="list-style-type: none"> <li><b>Green On</b> = Phone detected.</li> </ul>
Phone	<ul style="list-style-type: none"> <li>None.</li> </ul>

## 6.7 Connecting Phones

During initial power up, the IP Office automatically creates extension and user entries for all analog and digital extension ports in the system. This allows those devices to be connected immediately.

- **! Warning**

If the system has been upgraded from a previous release of IP Office software, all phones are restricted from making any calls until an upgrade license has been entered. The dialing restriction includes not being able to make emergency calls.

- This section does not cover the installation of DECT, H323 and SIP telephones. For installation of those devices refer to the appropriate supplementary installation manuals.

### 6.7.1 Analog Phones

Connect any analog phones to their appropriate [Phone](#)<sup>266</sup> ports. Ensure that those connected to [power failure ports](#)<sup>47</sup> are clearly labeled as such.

### 6.7.2 DS Digital Station Phones

Connect any digital phones to their appropriate [DS](#)<sup>262</sup> ports. These phones may need to upgrade their firmware to match that supported by the IP Office core software. The appropriate firmware is supplied with the IP Office Manager software and copied onto the System SD card for IP500 V2 systems.

The phones will automatically load the firmware from the IP Office system if necessary.

- The upgrade process takes approximately 10 minutes during which time the phone will display a warning. The phone should not be disconnected during this process.
- Once the phone connected to a port has been upgraded, the IP Office will not check whether the phone on that port needs to be upgraded again except following a system reboot, i.e. multiple phones cannot be upgraded by swapping the connected phones on the same port.

### 6.7.3 IP/SIP Phones

The installation and configuration of H323 and SIP IP telephones is not covered by this document. Refer to the appropriate IP Office installation manual for the type of phone being installed.



# Chapter 7.

## Initial Configuration using Manager

---

## 7. Initial Configuration using Manager

This section covers basic configuration changes required for IP Office systems using the IP Office Manager application. This covers just the basic configuration, the full range of configuration possible through IP Office Manager is covered in the [IP Office Manager manual](#)<sup>11</sup>.

### Summary

1. [Network Connection](#)<sup>103</sup>  
Use IP Office Manager to connection to the new system.
2. [Initial Configuration](#)<sup>105</sup>  
The **Initial Configuration** menu is shown the first time that IP Office Manager or IP Office Web Manager connects to a new system.
3. [Set the Extension Numbering](#)<sup>106</sup>  
Renumber all the user extensions if required.
4. [Disable any Unused Trunks](#)<sup>107</sup>  
Disabling the use of trunks and trunk channels that are not available.
5. [Select the Clock Source for Digital Trunks](#)<sup>108</sup>  
Altering which digital trunk is used to provide the IP Office with its clock signal for call synchronization.
6. [Enter Trunk Prefixes](#)<sup>110</sup>  
On systems where a prefix is being used for external dialing, ensure that the same prefix is added to incoming numbers in order to allow return calls.
7. [Uploading the License File](#)<sup>111</sup>  
Upload the license file provided for the system and check the license status for the licenses.

### Basic Security Configuration

After completing the basic configuration, you should follow the processes in the [System Security](#)<sup>130</sup> chapter.

## 7.1 Network Connection

This section below details how a new IP Office system determines what IP address it should use.

When a defaulted or new IP Office control unit is switched on, it requests IP address information from a DHCP Server. This occurs regardless of whether a LAN cable is connected or not. The process is done separately for both the LAN port (LAN1 in the configuration) and the WAN port (LAN2 in the configuration).

1. The system makes a DHCP request for IP address information.
2. If a DHCP server responds within approximately 10 seconds, the control unit defaults to being a DHCP client and uses the IP address information supplied by the DHCP server.
3. If no DHCP Server responds, the control unit still defaults to being the DHCP client but assumes the following default addresses (Note that the IP Office does not check that these addresses are valid and or available on the network.):
  - **LAN Port (LAN1):** 192.168.42.1/255.255.255.0.
  - **WAN Port (LAN2):** 192.168.43.1/255.255.255.0.
- Systems can be configured as a DHCP server. They can also be configured to only provide DHCP for Avaya IP phones and or for remote access dial-in connections.
- **!** Once an IP500 V2 control unit has obtained IP address and DHCP mode settings, it will retain those settings even if rebooted without a configuration file present on the System SD card. To fully remove the existing IP address and DHCP mode settings, you must [default the system configuration](#)<sup>167</sup>.

### PC Connection

Depending on the conditions that applied when the IP Office control unit was first started, a PC can be connected as follows:

- **If the control unit is not connected to a network:**  
Connect the PC directly to the control unit. Set the PC to an address valid on the same network as the IP Office defaults above. For example 192.168.42.203/255.255.255.0.
- **If the control unit is connected to a network with no DHCP server:**  
Connect the PC directly to the control unit. Set the PC to an address valid on the same network as the IP Office defaults above. For example 192.168.42.203/255.255.255.0.
- **If the control unit is connected to a network with a DHCP server:**  
Connect the PC to the network. The PC must be set as a DHCP client or to an address that is valid for that network.
  - If using IP Office Manager, its **Select IP Office** menu can locate the control unit.
  - Otherwise, the address being used by the control unit system needs to be determined from the DHCP server. Most DHCP servers can list the clients registered to them.
- **If the control unit is using a pre-built configuration:**  
Use the IP addresses as set in that configuration. Ensure that the PC is on the same subnet or on a network able to route to and from that subnet.

## To login to a system using IP Office Manager:

1. Select **Start | All Programs | IP Office | Manager**.
2. Check the default settings for the application:
  - a. Click **File | Preferences**.
  - b. If you don't expect to ever manage any IP Office Basic Edition systems, select **Default to Standard Mode**, and unselect **Set Simplified View as default**.
  - a. Click **OK**.
3. Click  or select **File | Open Configuration** from the menu bar.
4. The **Select IP Office** window appears. After a few seconds it should list the IP Office control unit. The default display name used for a newly installed IP Office control unit is its MAC address.

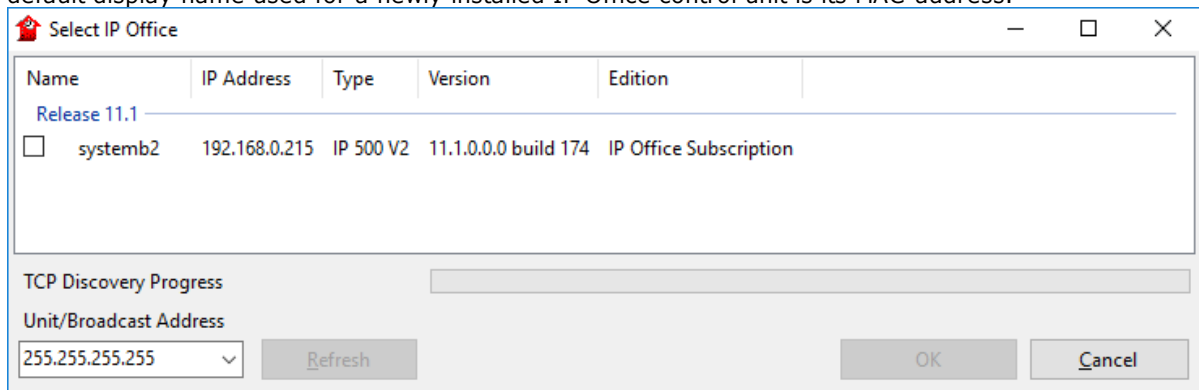

- If the system required was not found, the address used for the search can be changed. Enter or select the required address in the **Unit/Broadcast Address** field and then click **Refresh** to perform a new search.
5. Click the check the box next to the system and then click **OK**.
  6. The name and password request is displayed. The default name and password are **Administrator**.
  7. You are now prompted to go through the initial configuration menu. See [Initial Configuration](#)<sup>105</sup>.

## 7.2 Initial Configuration

The initial configuration menus appear the first time IP Office Manager connects to a new or defaulted system.

- For an existing system, this menu can be rerun by selecting **File | Advanced | Initial configuration** in IP Office Manager or **Actions | Service Commands | Initial Configuration** in IP Office Web Manager.

### To start the initial configuration using IP Office Manager:

- Having [connected to the new system](#)<sup>103</sup>, you are prompted to change the default passwords.
  - Administrator Password:** This password is used for access to the system's telephony configuration.
  - Security Administrator Password:** This password is used for access to the system's security configuration. Note that by default the administrator password above can also be used for security configuration.
  - System Password:** This password is used for system upgrades using IP Office Manager and can also be used for connecting System Monitor.
- Enter the new passwords and click **OK**.
- The **Initial Configuration** menu prompts you for a number of key settings.

Setting	Description
<b>System Mode</b>	For an IP Office Essential Edition or IP Office Preferred Edition system, select <b>IP Office Standard Edition</b> .
<b>System Name</b>	Used to help identify and access the system.
<b>Retain Configuration</b>	This option appears if this menu is rerun on an existing system. If selected, the system attempts to retain as much of the configuration as is compatible with the other selections made in this menu.
<b>Locale</b>	This sets a range of settings to match the telephony requirements of that selected country. It also sets the default language for the system and all users.
<b>Default Extension Password</b>	This password is used for the initial registration of IP extensions.
<b>Under Centralized Management</b>	This setting is used for branch systems in a Avaya Aura network. Refer to the separate <a href="#">branch installation documentation</a> <sup>11</sup> .
The following settings are used to configure the systems IP address settings:	
<b>Public LAN Interface</b>	This option performs two roles: <ol style="list-style-type: none"> <li>It is used to display the IP address settings of each of the system's two LAN ports. <b>LAN1</b> matches the port on the control unit labeled <b>LAN</b>, <b>LAN2</b> matches the port labeled <b>WAN</b>. Check that these settings are as required.</li> <li>The final selection is used to set which of the ports is connected to the customer network that should be used for external internet access via the customer firewall or similar. The <b>Gateway</b> address of that LAN is then added to the system's IP routes as the default IP route.</li> </ol>
<b>IP Address</b>	Set the IP address of the system on the currently selected LAN interface.
<b>IP Mask</b>	Set the IP address mask of the system on the currently selected LAN interface.
<b>Gateway</b>	Set the IP address of the external router.

- Click **Save**. The new configuration is opened in IP Office Manager.
- This configuration has not as yet been saved to the system. Either:
  - Continue the basic configuration using the following sections of this chapter and then save the configuration when finished.
  - [Save the configuration](#)<sup>112</sup> as it currently is. This may cause the system to reboot, the save menu will indicate if that is required. After saving the configuration, reload the configuration and continue with configuration.
    - Note: Because the passwords have now been changed from their defaults, you are prompted to enter the new password when saving.

## 7.3 Extension Numbering

The system can use a mix of extension numbers up to 15 digits in length. By default, hunt groups and extensions are given 3-digit extension numbers starting from 200 upwards.

### To renumber all user extensions using IP Office Manager:

IP Office Manager can be used to renumber all extensions on the system. This will also update any references to the extension number in other configuration fields.

1. With the system configuration, select **Tools | Extension Renumber**.

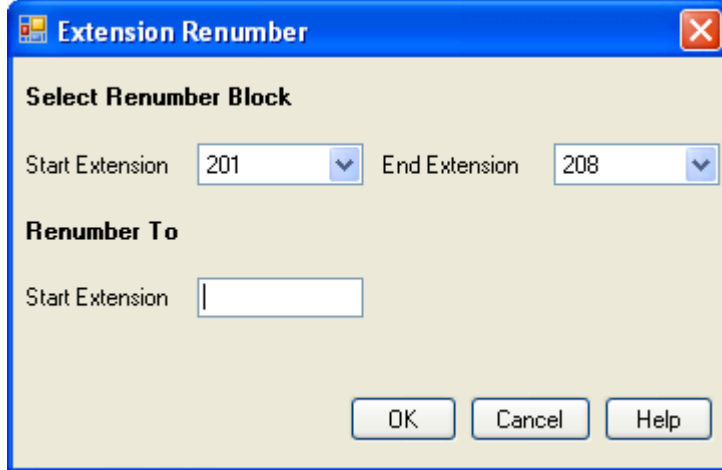

2. Select the range of existing user extensions you want renumber and enter the new starting extension number for that range.
3. Click **OK**.
4. Either:
  - Continue the basic configuration using the following sections of this chapter and then save the configuration when finished.
  - [Save the configuration](#)<sup>112</sup> as it currently is. This may cause the system to reboot, the save menu will indicate if that is required. After saving the configuration, reload the configuration and continue with configuration.
5. Continue with the [basic configuration](#)<sup>107</sup> or click on the  save icon to [save the updated configuration](#)<sup>112</sup> and then continue.

## 7.4 Disable Unused Trunks

Each trunk card or module provides a fixed number of trunk ports, with each digital trunk port supporting a number of digital channels. By default, the configuration contains entries for all the possible trunks and channels.

In cases where the number of trunks or trunk channels useable is lower than the number supported by the trunk card, the unused trunks and channels must be disabled. Failure to do this will cause problems with outgoing calls.

- For IP500 Analog Trunk 4 V2 cards and ATM4 Combination V2 cards, the system can detect with analog trunks are connected and so can automatically treat unconnected trunk ports as out of service.

- **! WARNING**

The processes below require the IP Office system to reboot in order to apply any changes made. The reboot ends all current calls and services.

### To disable unused trunks using IP Office Manager:

- Within the IP Office configuration, select  **Line**.
- For each line, set those lines or channels that are not connected or being used as **Out of Service**. The location of the relevant setting varies depending on the trunk type.

- **Analog Trunks**

To disable the whole trunk, on the main form, set the **Admin** option to **Out of Service**.

- **BRI, E1 PRI, S0 and QSIG Trunks**

To disable the whole trunk, set the **Admin** option to **Out of Service**. Otherwise, set the number of channels to match the actual subscribed channels.

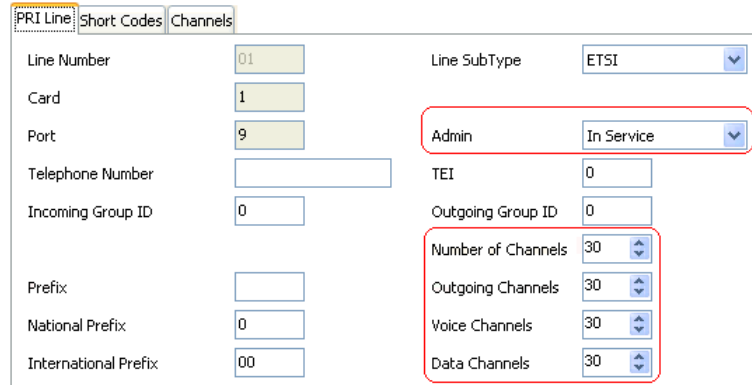

Line Number: 01, Line SubType: ETSI, Card: 1, Port: 9, Telephone Number: [empty], Incoming Group ID: 0, Prefix: [empty], National Prefix: 0, International Prefix: 00, Admin: In Service, TEI: 0, Outgoing Group ID: 0, Number of Channels: 30, Outgoing Channels: 30, Voice Channels: 30, Data Channels: 30.

- **T1, T1 PRI and E1R2 Trunks**

To disable the whole trunk, set the **Admin** option to **Out of Service**. Otherwise, select the **Channels** tab and set those channels that are not used to **Out of Service**.

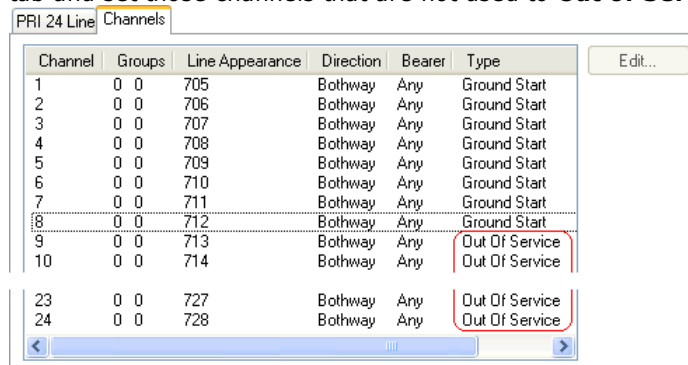

Channel	Groups	Line Appearance	Direction	Bearer	Type
1	0 0	705	Bothway	Any	Ground Start
2	0 0	706	Bothway	Any	Ground Start
3	0 0	707	Bothway	Any	Ground Start
4	0 0	708	Bothway	Any	Ground Start
5	0 0	709	Bothway	Any	Ground Start
6	0 0	710	Bothway	Any	Ground Start
7	0 0	711	Bothway	Any	Ground Start
8	0 0	712	Bothway	Any	Ground Start
9	0 0	713	Bothway	Any	Out Of Service
10	0 0	714	Bothway	Any	Out Of Service
23	0 0	727	Bothway	Any	Out Of Service
24	0 0	728	Bothway	Any	Out Of Service

- For T1 channels, set the **Type** to **Out of Service**.
- For T1 PRI channels, set the **Admin** field to **Out of Service**.
- For E1R2 channels, set the **Line Signalling Type** to **Out of Service**.

- Then, either:

- Continue the basic configuration using the following sections of this chapter and then save the configuration when finished.
- [Save the configuration](#) <sup>112</sup> as it currently is. This may cause the system to reboot, the save menu will indicate if that is required. After saving the configuration, reload the configuration and continue with configuration.

---

## 7.5 Setting the Digital Trunk Clock Source

Digital trunks require the systems at each end of the trunk to share a clock signal to ensure synchronization of call signaling. The IP Office can obtain and use the clock signal from any of its digital trunks. Typically the clock signal provided by a digital trunk from the central office exchange is used as this is usually the most accurate and reliable clock source.

If no trunk clock source is available, the system can use its own internal clock if necessary. However, an external trunk source is preferred. To do this, the **Clock Quality** setting on each line in the IP Office configuration is set to one of the following:

- **Network**  
If available, the clock signal from this trunk should be used as the clock source for call synchronization. If several trunk are configured with this setting, the trunk used is determined in the order of slots 1 to 4 and then by port on each slot.
- **Fallback**  
If available, the clock signal from this trunk can be used as the clock source if none of the trunks set as **Network** are providing a clock source. If several trunk are configured with this setting, the trunk used is determined in the order of slots 1 to 4 and then by port on each slot.
- **Unsuitable**  
The clock source from this trunk will not be used as the clock source.

In the example below the first IP Office is set to use the public network trunk as its clock source and ignoring the possible clock source from the QSIG trunk. The other IP Office system is using the clock signal received from the first IP Office on its QSIG trunk as its clock source. Thus both IP Offices are using the same clock source and that clock source is the public network exchange.

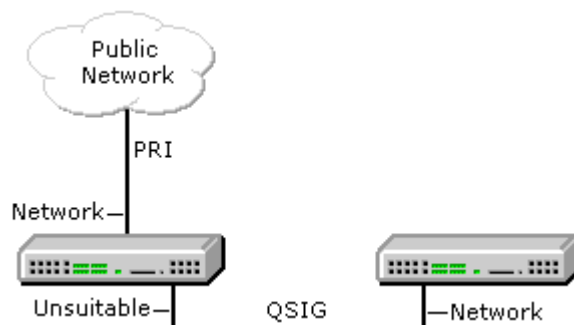

### Viewing the Current Clock Source

The current clock source being used by an IP Office system is shown on the **Resources** page within the System Status Application.

**To set a trunk's clock quality source using IP Office Manager:**

1. Within the IP Office configuration, select **Line**.
2. For each digital line, select the line and on the **Line** tab select how that trunk's clock source should be used by the system. For E1R2 trunks, the **Clock Quality** setting is on the **Advanced** tab.

PRI 24 Line Channels

Line Number	01	Line SubType	T1
Channel Allocation	24 -> 1		
Prefix			
Clock Quality	Network	Framing	ESF
CRC Checking	Network	Zero Suppression	B&ZS
CSU Operation	<input type="checkbox"/>	Line Signalling	CPE
Haul Length	0-115 ft	Incoming Routing Digits	4
Channel Unit	Foreign Exchange		

- Ensure that only one trunk is set to **Network**. This should preferably be a direct digital trunk to the central office exchange.
  - One other trunk can be set as **Fallback** should the selected **Network** trunk connection be lost. If possible, this should be a trunk from a different provider since that reduces the chances of both sources failing at the same time.
  - Ensure that all other digital trunks are set as **Unsuitable**.
3. Then, either:
    - Continue the basic configuration using the following sections of this chapter and then save the configuration when finished.
    - [Save the configuration](#)<sup>112</sup> as it currently is. This may cause the system to reboot, the save menu will indicate if that is required. After saving the configuration, reload the configuration and continue with configuration.

---

## 7.6 Setting the Trunk Prefixes

By default, systems with a U-Law System SD card default to using a 9 prefix for external calls. Systems started with an A-Law System SD card default to no prefix (any dialing that doesn't match an internal number is assumed to be an external number).

Where a prefix is used for outgoing calls, that same prefix needs to be added to trunk settings. That trunk prefix is then used as follows:



- **Incoming Calls**

On incoming calls, the trunk's set prefix is added to any incoming caller ID received with the call and stored in the call log on phones, etc. The prefix should be such that the resulting caller ID can be used by the systems phones and applications to make return calls. For example, if the system is configured to require a 9 to indicate an outgoing call, the trunk needs to add a 9 to the incoming caller ID so that that ID can be used for return calls.

- **Outgoing Calls**

On outgoing calls, the short codes used to route the call to a trunk must remove any external dialing prefix (for example 9) so that the number dialed from the system to the trunk is suitable for routing by the trunk provider.

### To set trunk prefixes using IP Office Manager:

1. Within the IP Office configuration, select  Line.
2. For each line enter the prefix. The location of the prefix settings varies for each trunk type. Some trunk types have a single prefix field. Other trunk types may have separate prefix fields for national, international and other calls.
3. Then either:
  - Continue the basic configuration using the following sections of this chapter and then save the configuration when finished.
  - [Save the configuration](#) <sup>112</sup> as it currently is. This may cause the system to reboot, the save menu will indicate if that is required. After saving the configuration, reload the configuration and continue with configuration.

## 7.7 Uploading the License File

The IP Office system requires licenses for some features, see [Licenses](#)<sup>109</sup>. The license file can be either uploaded manually or [pre-loaded onto the System SD card](#)<sup>80</sup>.



### How is the system licensed?

- An XML file containing the full set of PLDS licenses is uploaded to the system. The license file is unique to the feature key serial number of the System SD card installed in the system.
- The card's ID number is printed on the card's label after **PLDS ID**, **FK SN** or **FK** depending on the age of the card. On newer cards is a 12-digit number. Older cards may have a 10-digit number. For PLDS licensing, use the 12-digit number. On older cards, for licensing, prefix the 10-digit number with **11**.

### Minimum License Requirements

For IP Office Essential Edition, the system requires an **Essential Edition** system license for the specific IP Office release you want it to run.

### To upload the license file using IP Office Manager:

1. Within the system configuration click on  **License**.
2. The field **PLDS Host ID** shows the serial number of the System SD card fitted to the system. Check that this number matches the one against which the licenses have been issued.
  - The card's ID number is printed on the card's label after **PLDS ID**, **FK SN** or **FK** depending on the age of the card. On newer cards is a 12-digit number. Older cards may have a 10-digit number. For PLDS licensing, use the 12-digit number. On older cards, for licensing, prefix the 10-digit number with **11**.
3. Click **Add...**
4. For the license type select **PLDS** and click **OK**.
5. Browse to the location of the XML file supplied containing the licenses. Select the file and click **Open**.
6. Continue with the [basic configuration](#)<sup>112</sup> or click on the  save icon to [save the updated configuration](#)<sup>112</sup> and then continue.

## 7.8 Saving the Configuration

Having completed the basic configuration, the new configuration needs to be saved back to the system. This will very likely require the system to reboot.

After saving the configuration, reload it into IP Office Manager;

- If the IP address settings were changed, you may need to change your PC settings to reload the configuration.
- After reloading the configuration, any licenses should now be listed as **Valid**.

### To save configuration changes using IP Office Manager:

1. Click **OK** to save any changes to the current menu.
2. Click on the  icon. The **Save Configuration** menu appears.

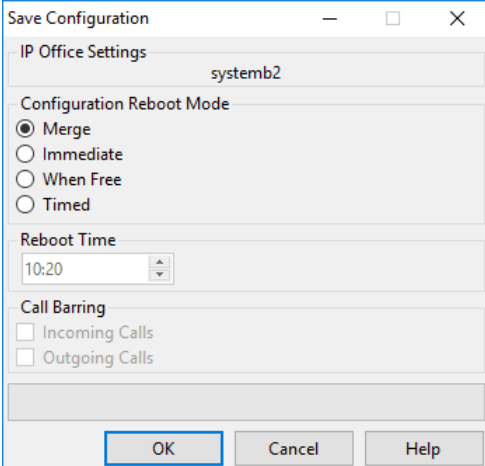

- **Merge**  
This method is automatically selected if none of the configuration changes made require a system reboot. If this method is used for a configuration that includes changes that do require a reboot, those changes are not applied until the system is manually rebooted.
- **Immediate**  
This method saves the new configuration changes and then restarts the system. Any current calls and services in progress are ended. This method is automatically selected if any of the changes made so far require a reboot before they are applied to the system.
- **Free**  
This method allows the **Incoming Call Barring** and **Outgoing Call Barring** options to be used. The system reboots when the criteria for the selected options are matched.
- **Timed (HH:MM)**  
This method reboots the the system at the selected time. It can also be used with the call barring options to only reboot after the set time when the selected options are matched.
- **Incoming Call Barring**  
This option can be used with the **Free** and **Timed** reboot methods. When selected, the system bars any further incoming calls. However, it allows existing calls to continue until they are ended.
- **Outgoing Call Barring**  
This option can be used with the **Free** and **Timed** reboot methods. When selected, the system bars any further outgoing calls. However, it allows existing calls to continue until they are ended.
  - **! WARNING:** This option also bars the making of emergency calls. Therefore, it should be used with caution.

4. Select the options required and click **OK**.

### Basic Security Configuration

After completing the basic configuration, you should follow the processes in the [System Security](#)<sup>130</sup> chapter.

# Chapter 8.

## Initial Configuration Using IP Office Web Manager

---

## 8. Initial Configuration Using IP Office Web Manager

You can use your web browser to configure an IP500 V2 system through its IP Office Web Manager menus. For new IP500 V2 systems, that includes running a series of initial wizard configuration menus to cover key settings for a new system.

### 8.1 The System's Initial IP Address

In order to connect to a new system using a browser, you first need to determine what IP address the system has adopted.

This section below details how a new IP Office system determines what IP address it should use.

When a defaulted or new IP Office control unit is switched on, it requests IP address information from a DHCP Server. This occurs regardless of whether a LAN cable is connected or not. The process is done separately for both the LAN port (LAN1 in the configuration) and the WAN port (LAN2 in the configuration).

1. The system makes a DHCP request for IP address information.
2. If a DHCP server responds within approximately 10 seconds, the control unit defaults to being a DHCP client and uses the IP address information supplied by the DHCP server.
3. If no DHCP Server responds, the control unit still defaults to being the DHCP client but assumes the following default addresses (Note that the IP Office does not check that these addresses are valid and or available on the network.):
  - **LAN Port (LAN1):** 192.168.42.1/255.255.255.0.
  - **WAN Port (LAN2):** 192.168.43.1/255.255.255.0.
- Systems can be configured as a DHCP server. They can also be configured to only provide DHCP for Avaya IP phones and or for remote access dial-in connections.
- **!** Once an IP500 V2 control unit has obtained IP address and DHCP mode settings, it will retain those settings even if rebooted without a configuration file present on the System SD card. To fully remove the existing IP address and DHCP mode settings, you must [default the system configuration](#)<sup>167</sup>.

#### PC Connection

Depending on the conditions that applied when the IP Office control unit was first started, a PC can be connected as follows:

- **If the control unit is not connected to a network:**  
Connect the PC directly to the control unit. Set the PC to an address valid on the same network as the IP Office defaults above. For example 192.168.42.203/255.255.255.0.
- **If the control unit is connected to a network with no DHCP server:**  
Connect the PC directly to the control unit. Set the PC to an address valid on the same network as the IP Office defaults above. For example 192.168.42.203/255.255.255.0.
- **If the control unit is connected to a network with a DHCP server:**  
Connect the PC to the network. The PC must be set as a DHCP client or to an address that is valid for that network.
  - If using IP Office Manager, its **Select IP Office** menu can locate the control unit.
  - Otherwise, the address being used by the control unit system needs to be determined from the DHCP server. Most DHCP servers can list the clients registered to them.
- **If the control unit is using a pre-built configuration:**  
Use the IP addresses as set in that configuration. Ensure that the PC is on the same subnet or on a network able to route to and from that subnet.

## 8.2 Initial Configuration

Having determined the new systems IP address and configured your PC to be able to connect to addresses in that range:

1. In your web browser:
  - a. Enter the control unit's current IP address in the browser address bar.
  - b. Click **IP Office Web Manager**. The address shown is now similar to `https://192.168.0.42:8443/WebMgmtEE/WebManagement.html`.
2. The connection as this stage may not be seen as secure. Follow whichever steps your browser provides for continuing with an unsecure connection.
  - For example, in Chrome, select **SHOW ADVANCED** and then **Proceed**.
  - Once the system is installed, its security certificate can be downloaded to remove the need for this in future. See [Adding the System Certificate to a Browser](#)<sup>155</sup>.
3. At the login menu, login using the default name and password **Administrator**.
4. You are prompted to change the default passwords.
  - **Administrator Password:** This password is used for access to the system's telephony configuration.
  - **Security Administrator Password:** This password is used for access to the system's security configuration. Note that by default the administrator password above can also be used for security configuration.
  - **System Password:** This password is used for system upgrades using IP Office Manager and can also be used for connecting System Monitor.
5. If a license agreement is shown, read the license and then click **Accept** and **OK**.
6. Click on the **System** icon.

System Configuration-00E00705219A

GENERAL			
System Name *	Services Device ID	DNS Server	Locale
00E00705219A		0 . 0 . 0 . 0	United States (US English)
System Mode	Activate Mode	Phone Password	
Standard	None	.....	
LAN Interface			
LAN1 CONFIGURATION			
IP Address	IP Subnet Mask	DHCP Mode	Enable NAT
192 . 168 . 0 . 35	255 . 255 . 255 . 0	Disabled	NO
LAN2 CONFIGURATION			
IP Address	IP Subnet Mask	DHCP Mode	Enable NAT
192 . 168 . 43 . 1	255 . 255 . 255 . 0	Disabled	NO
Gateway	0 . 0 . 0 . 0		
TIME SETTINGS			
Time Setting Configuration Source	Time Server IP Address	Time Offset	Local Time Offset from UTC
Voicemail Pro/Manager	0 . 0 . 0 . 0	00:00	-06:00
Automatic DST	Clock Forward/Back Settings (Start Date - End Date (DST Offset))		
NO	2014-03-09 02:00:00 - 2014-11-02 02:00:00(01:00)		Edit Delete
<input type="button" value="Back"/> <input type="button" value="Apply"/> <input type="button" value="Reset"/>			

7. Enter the details that you want the system to use. For full details of the **System** options, see [System Settings](#)<sup>119</sup>. At this stage, the key values are:

Setting	Description
<b>System Mode</b>	For an IP Office Essential Edition or IP Office Preferred Edition system, select <b>IP Office Standard Edition</b> .
<b>System Name</b>	Used to help identify and access the system.
<b>Retain Configuration</b>	This option appears if this menu is rerun on an existing system. If selected, the system attempts to retain as much of the configuration as is compatible with the other selections made in this menu.
<b>Locale</b>	This sets a range of settings to match the telephony requirements of that selected country. It also sets the default language for the system and all users.

Setting	Description
<b>Default Extension Password</b>	This password is used for the initial registration of IP extensions.
<b>Under Centralized Management</b>	This setting is used for branch systems in a Avaya Aura network. Refer to the separate <a href="#">branch installation documentation</a> <sup>11</sup> .
The following settings are used to configure the systems IP address settings:	
<b>Public LAN Interface</b>	This option performs two roles: <ul style="list-style-type: none"> <li>a. It is used to display the IP address settings of each of the system's two LAN ports. <b>LAN1</b> matches the port on the control unit labeled <b>LAN</b>, <b>LAN2</b> matches the port labeled <b>WAN</b>. Check that these settings are as required.</li> <li>b. The final selection is used to set which of the ports is connected to the customer network that should be used for external internet access via the customer firewall or similar. The <b>Gateway</b> address of that LAN is then added to the system's IP routes as the default IP route.</li> </ul>
<b>IP Address</b>	Set the IP address of the system on the currently selected LAN interface.
<b>IP Mask</b>	Set the IP address mask of the system on the currently selected LAN interface.
<b>Gateway</b>	Set the IP address of the external router.

8. When the system settings are set as required, click **Apply**. The dashboard now contains a series of other icons for working through the initial configuration of the system.

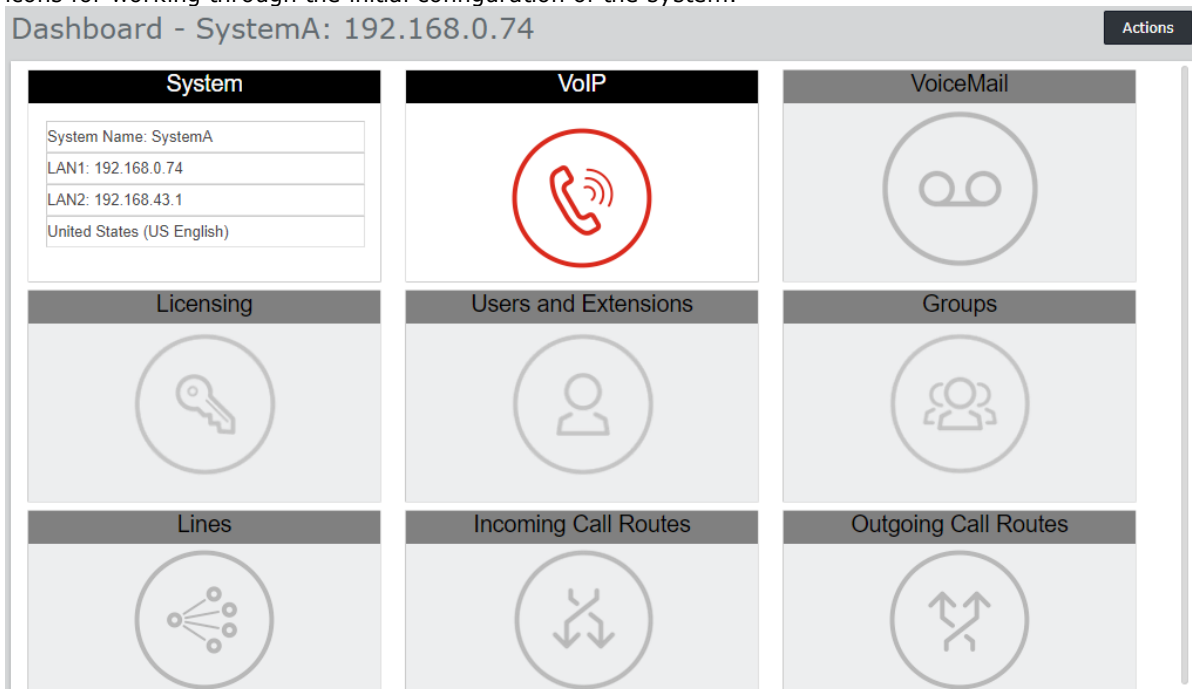

9. The next icon to click is highlighted in red. After you complete each set of settings, the icon in the panel is replaced with a summary of the key settings and the next icon is highlighted. You can return to previous panels if you want to make further changes to their settings. For details of the individual panels see [Dashboard Wizard Menus](#)<sup>118</sup>.

10. Once you have completed all the steps of the wizard, click the **Save to IP Office** link shown in the yellow bar at the top of the window.

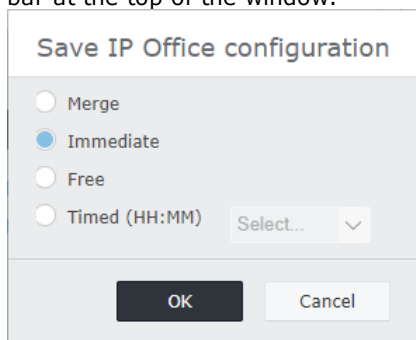

The image shows a dialog box titled "Save IP Office configuration". It contains four radio button options: "Merge", "Immediate", "Free", and "Timed (HH:MM)". The "Immediate" option is selected. To the right of the "Timed (HH:MM)" option is a dropdown menu with the text "Select..." and a downward arrow. At the bottom of the dialog box are two buttons: "OK" and "Cancel".

11. The save configuration menu is displayed with a recommended save setting based on the changes you have made. For a new install this is likely to be a save using an immediate reboot of the new system. Accept the recommended setting and click **OK**.
12. After the reboot, continue the system configuration using the system's new IP address.

## 8.3 Dashboard Wizard Menus

This section provides a summary of the dashboard wizard menus only. For full details refer to the "Administering IP Office System Using Web Manager" help and manual.

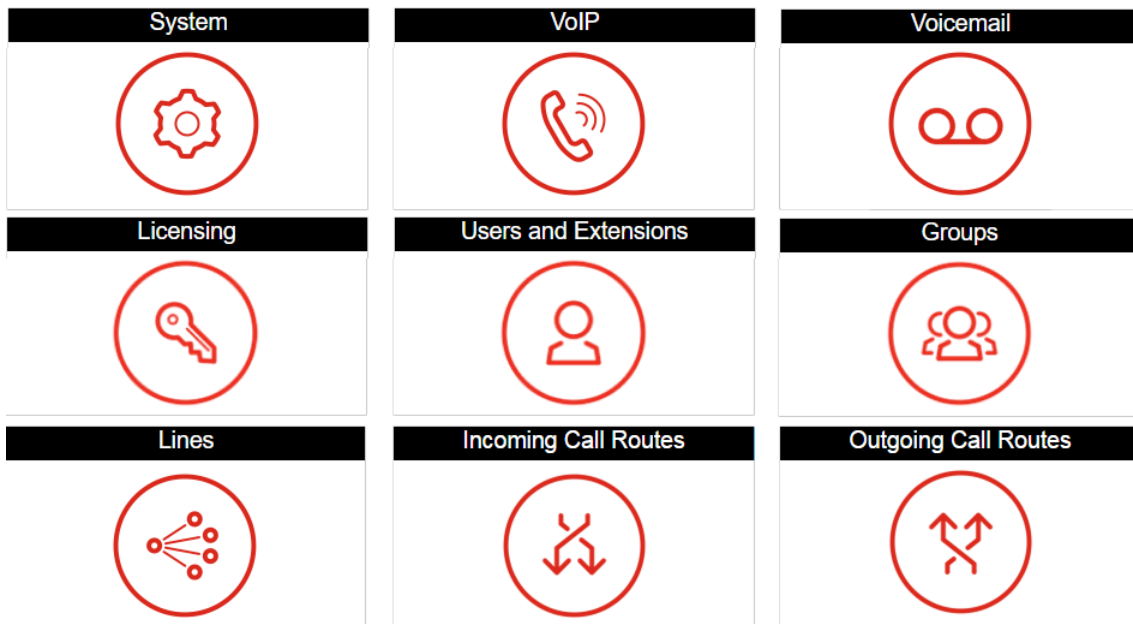

- [System](#)<sup>119</sup>
- [Licensing](#)<sup>123</sup>
- [Lines](#)<sup>126</sup>
- [VoIP](#)<sup>121</sup>
- [Users and Extensions](#)<sup>124</sup>
- [Incoming Call Routes](#)<sup>127</sup>
- [Voicemail](#)<sup>122</sup>
- [Groups](#)<sup>125</sup>
- [Outgoing Call Routes](#)<sup>128</sup>  
(United States/Canada only)

### 8.3.1 System Settings

This panel allows the setting of a number of key settings (location, mode, IP address and time/date settings).

GENERAL			
System Mode	System Name*	Locale	
IP Office Subscription	systema	South Africa (UK English)	
Default Extension Password	Retain Configuration		
.....	<input type="checkbox"/> NO		
SUBSCRIPTION SYSTEM DETAILS			
System ID	Customer ID	License Server Address	
111316383730	9186064	admin.ipocloud.com	
Public LAN Interface			
LAN1			
LAN1 CONFIGURATION			
IP Address	IP Subnet Mask	DHCP Mode	Enable NAT
192 . 168 . 0 . 210	255 . 255 . 255 . 0	Disabled	<input type="checkbox"/> NO
LAN2 CONFIGURATION			
IP Address	IP Subnet Mask	DHCP Mode	Enable NAT
192 . 168 . 1 . 212	255 . 255 . 255 . 0	Disabled	<input type="checkbox"/> NO
Gateway			
192 . 168 . 0 . 1			
Cancel	Apply	Reset	

#### General

- **System name**  
This name is used to identify the system in other tools and menus.
- **Retain Configuration**  
This option is shown if the dashboard is being used to reconfigure an existing system. If selected, this option will retain as much of the existing configuration as possible. If disabled, all existing configuration settings are returned to their defaults.
- **Locale**  
This value sets a large number of system defaults that are location specific, especially settings relating to telephony. Therefore it is important to set this value correctly to match the actual system location.
- **System Mode**  
The IP500 V2 can be used in a number of modes:
  - **IP Office Basic Edition**  
This option should be selected for a system that will run in one of the IP Office Basic Edition modes. This option is only available when configuring a new IP500 V2. If selected, the dashboard will only show the System settings. For details refer to the Server Edition documentation.
  - **IP Office Standard Edition**  
This option should be selected for a system that should run in either IP Office Essential Edition or IP Office Preferred Edition mode.
  - **IP Office Server Edition Expansion**  
This option is used for systems being installed as an expansion unit in a Server Edition or IP Office Select network. For details refer to the Server Edition documentation.
  - **IP Office Subscription**  
This option is used to set the system to use subscription settings.
- **Phone Password**  
This values sets the default phone password used for the initial registration of IP phone extensions.

#### LAN Interface

These fields are used to set the IP address settings of the system's LAN1 (LAN) and LAN2 (WAN) ports.

- **Public LAN Interface**  
Select the LAN interface (LAN1 or LAN2) that is connected to the customer's public facing internet service (ie. their router or firewall). The selection affects some of the default IP routes added to the configuration.

---

## Time Settings

This section sets the time source for the system. The fields available depend on the time source selected.

- **Time Setting Configuration Source**

This field is used to set the time source the system should use.

- **SNTP**

If selected, the system will obtain its date and time information from the configured time server address, for example **0.pool.ntp.org**. The additional settings available are to then apply a time zone, time offset and daylight saving time (DST) options if required.

- **Voicemail Pro/Manager**

If selected, the system will request date and time information from the server running the Voicemail Pro application or IP Office Manager.

- **None**

If selected, the system date and time will need to be set manually. That can be done from an Avaya phone where the user is set as a system phone user. Refer to the IP Office Manager help.

## 8.3.2 VoIP Settings

This tab is used to enable basic support for IP telephony, trunks and extensions, via H323 and or SIP connections.

- **! Warning:**

Do not enable any settings unless you are sure that the system will be using H323 or SIP connections. Enabling unnecessary connections introduces additional security requirements which, if not meet, may place the system at risk.

### VoIP Configuration

**LANS**

Select LAN

LAN1

---

**H.323 GATEKEEPER**

<b>H.323 Gatekeeper Enable</b>	<b>H.323 Signaling Over TLS</b>	<b>Auto-create Extension</b>	<b>H.323 Remote Extension Enable</b>
<input checked="" type="checkbox"/> YES	<div style="border: 1px solid #ccc; padding: 2px;">Disabled</div>	<input type="checkbox"/> NO	<input type="checkbox"/> NO

---

**SIP REGISTRAR**

<b>SIP Trunks Enable</b>	<b>SIP Registrar Enable</b>
<input checked="" type="checkbox"/> YES	<input type="checkbox"/> NO

- **Select LAN**

Select the LAN being configured.

- **H.323 Gatekeeper Enable**

Only select this option if the system will be installed with H.323 trunks and extensions.

- **H.323 Signaling Over TLS**

Support H.323 signaling using TLS. Note that enabling this requires additional configuration and reduces the overall IP phone capacity of the system.

- **Auto-Create Extension**

If is selected, the system automatically creates user and SIP extension entries in its configuration based on SIP extension registration. This setting is automatically disabled the settings 24-hours after it is enabled.

- **H.323. Remote Extension Enable**

Enable to support Avaya H.323 telephones located at remote locations.

- **SIP Trunks Enable**

Only select this option if the system will be installed with SIP trunks.

- **SIP Registrar Enable**

Only select this option if the system will be installed with SIP extensions. When selected, the following additional options are shown:

- **Auto-create Extn/User:** *Default = Off*

If is selected, the system automatically creates user and SIP extension entries in its configuration based on SIP extension registration. This setting is automatically disabled the settings 24-hours after it is enabled.

- **SIP Remote Extn Enable:** *Default = Off*

Currently remote SIP extension options are only supported for Avaya SIP client applications. Remote connection is not supported for third-party SIP devices.

- **SIP Domain Name:** *Default = Blank*

This value is used by SIP endpoints for registration with the system. If left blank, registration uses the LAN IP address. The entry should match the domain suffix part of the **SIP Registrar FQDN** below, for example *acme.com*.

- Note: For Avaya SIP telephones supported for resilience, the **SIP Domain Name** must be common to all systems in the network.
- This is the local SIP registrar domain name that needed by SIP devices in order to register with the IP Office. If you are using TLS, this value needs to be included in the security certificates applied to the IP Office and, if used, separate HTTP file server.

- **SIP Registrar FQDN:** *Default = Blank*

This is the fully-qualified domain name, for example *example.acme.com*, to which the SIP endpoint should send its registration requests. This address must be resolvable by DNS to the IP address of the IP Office system.

### 8.3.3 Voicemail Settings

This panel displays the voicemail and default music on hold settings of the system. If using embedded voicemail, the form can also be used to configure auto-attendant to answer calls (up to 40).

#### Voicemail and Auto Attendant Configuration

**Voicemail**

Voicemail Type

---

**HOLD MUSIC**

System Source

Select a File

---

**Auto Attendant**

Name	Maximum Inactivity	AA Number	Direct Dial-By-Number	Dial By Name Match ...	Enable Local Recording	
<input type="checkbox"/> Default	8	01	Off	Last then First	On	<input type="button" value="edit"/> <input type="button" value="delete"/>

- **Voicemail Type**

The main selections options are listed below. For details of the other options refer to the IP Office Web Manager help. Additional fields are displayed depending on the selection.

- **Embedded Voicemail**

This option uses the system's own system SD card as the source for voicemail and storage for messages. This is a simple voicemail solution with only basic features. However, it does provide support for up to 40 auto-attendants.

- **Voicemail Pro/Lite**

Select this option if voicemail will be provided by a server running IP Office Voicemail Pro. Enter the IP address of the server.

- **Hold Music**

This option allows you to select the systems default source for music-on-hold. The options are:

- **WAV File**

Use a WAV file uploaded to the system. The file must be called **holdmusic.wav** and match the format list below. Use the Select a File option to select and upload the file.

Property	Value	Property	Value
<b>File Type</b>	WAV	<b>Audio Sample Rate</b>	8kHz
<b>Bit Rate</b>	128kbps	<b>Audio Format</b>	PCM
<b>Audio sample size</b>	16 bit	<b>Length</b>	Up to 90 seconds.
<b>Channels</b>	1 (mono)		

- **External**

Use the audio input from the system's Audio port on the rear of the control unit.

- **Tone**

Use a regular repeated tone generated by the system.

- **Auto Attendant**

If the Voicemail Type is set to Embedded Voicemail, the dashboard allows you to configure auto-attendants. These can be used as destinations for the Incoming Call Routing menu. The wizard automatically creates 3 time profiles call **Morning**, **Afternoon** and **Evening** for use by the auto-attendants. These are set to 08:00-11:59, 12:00-16:59 and 00:00-07:59, 7-days a week respectively.

### 8.3.4 Licensing Settings

This section of the dashboard allows you to add a license file for the system and to see what licenses were included in the file. An unlicensed system will not allow any telephone functions until licenses are added (at minimum for an IP500 V2 an **Essential Edition** license is required). The license file must match the PLDS

If the license file was placed on the [system SD card](#)<sup>80</sup> before the system was started, the licenses from the file are automatically added.

License | SystemA

**Manage Licenses**  
Manage Solution-Wide Licenses

Remote Server  
Configure License Server

License Mode	Licensed Version	Grace Period Days	PLDS Host ID	Grace PLDS Host ID	PLDS File Status
License Normal	-		111316383730	-	Valid

Grace System ID (ADI)  
-

PLDS License ▾

Feature	Instances	Status	Expiry Date	Source
Receptionist	4	Valid	2018-03-03	PLDS Nodal
Additional Voicemail Pro (...)	152	Valid	2018-03-03	PLDS Nodal
VMPro Recordings Admini...	1	Valid	2018-03-03	PLDS Nodal
Additional Embedded Voic...	4	Valid	2018-03-03	PLDS Nodal
VMPro TTS (Generic)	40	Valid	2018-03-03	PLDS Nodal
Teleworker	384	Valid	2018-03-03	PLDS Nodal
Mobile Worker	384	Valid	2018-03-03	PLDS Nodal
Office Worker	384	Valid	2018-03-03	PLDS Nodal
Avaya Softphone	100	Valid	2018-03-03	PLDS Nodal
VMPro TTS (Scansoft)	40	Valid	2018-03-03	PLDS Nodal
VMPro TTS Professional	40	Valid	2018-03-03	PLDS Nodal
IPSec Tunnelling	1	Valid	2018-03-03	PLDS Nodal
Power User	384	Valid	2018-03-03	PLDS Nodal
Avaya IP Endpoints	384	Valid	2018-03-03	PLDS Nodal
Voice Networking Channels	32	Valid	2018-03-03	PLDS Nodal

Displaying 1 - 31 of 31

Back

#### To add a license file:

1. Click **PLDS License** and select **Send To IP Office**.
2. Select the PLDS XML file provided for the system. The file must match the **PLDS Host ID** shown on the menu (that host ID is linked to the serial number of the system SD card fitted in the system).
3. Click **OK**. The file is uploaded to the system and replaces any previous license file and the licenses it may have contained.

### 8.3.5 Users and Extensions













































This form displays a list of user in the configuration. For a new IP500 V2 system, a user is automatically created for each physical phone port detected when the system was started.

To edit a particular user click on the  pencil icon. To add a new user, click **+Add User**. For full details of the user and extension settings refer to the IP Office Web Manager help. As you add users, you can use the panel on the left to filter which users are shown in the list.

**Users**
Actions ▾
**+ Add User**

Show All

Edit Multiple
Delete

	Name	Full Name	Extension	Hunt Gro...	Voicemail	Email Ad...	Password	Voicemail...	Login Code	
<input type="checkbox"/>	RemoteMa...				On					 
<input type="checkbox"/>	NoUser				On					
<input type="checkbox"/>	Extn201		201	Main	On					  
<input type="checkbox"/>	Extn202		202	Main	On					  
<input type="checkbox"/>	Extn203		203	Main	On					  
<input type="checkbox"/>	Extn204		204	Main	On					  
<input type="checkbox"/>	Extn205		205	Main	On					  
<input type="checkbox"/>	Extn206		206	Main	On					  
<input type="checkbox"/>	Extn207		207	Main	On					  
<input type="checkbox"/>	Extn208		208	Main	On					  
<input type="checkbox"/>	Extn209		209	Main	On					  
<input type="checkbox"/>	Extn210		210	Main	On					  
<input type="checkbox"/>	Extn211		211	Main	On					  
<input type="checkbox"/>	Extn212		212	Main	On					  
<input type="checkbox"/>	Extn213		213	Main	On					  
<input type="checkbox"/>	Extn214		214	Main	On					  

Displaying 1 - 18 of 18

Back

### 8.3.6 Groups

This form displays a list of groups in the configuration. For a new IP500 V2 system, one group, called **Main** and with the extension number 200, is automatically added. This group will contain all the phone extensions that were automatically created (one for each physical phone port) when the system was started.

To edit a particular group click on the  pencil icon. To add a new group, click **+Add Group**. For full details of the group settings and configuration refer to the IP Office Web Manager help . As you add groups, you can use the panel on the left to filter which groups are shown in the list.

**Groups**
+ Add Group

Show All

**Ring Modes**

Collective

Sequential

Rotary

Longest Waiting

Collective Call Waiting

**Profiles**

Standard Hunt Group

XMPP Group

Centralized Group

ICR Agent Group



Group of Application Servers

**Queuing**

On

Off

Search on 'Name', 'Extension' Delete 

	Name	Extension	Ring Mode	Profile	Queuing	
<input type="checkbox"/>	Main	200	Collective	Standard Hunt Group	On	 

Displaying 1 - 1 of 1

Back

### 8.3.7 Lines





This form displays a list of all the external lines. For a new IP500 V2 system, the analog, PRI and BRI lines are automatically added with default settings to match the physical line interfaces found in the system when it was started. Other line types need to be added manually.

To edit a particular line click on the  pencil icon. To add a new line, for example a SIP line, click **+Add Line** and select the line type required. For full details of line settings and configuration refer to the IP Office Web Manager help.

## Lines

+ Add Line ▾

Show All

LINE TYPE	Line Number	Line Type	Line Subtype	Gateway IP Address	
<input type="checkbox"/> BRI Line	5	Analog Line			
<input type="checkbox"/> H.323 Line	6	Analog Line			
<input type="checkbox"/> PRI30 Line	7	Analog Line			
<input type="checkbox"/> PRI24 Line	8	Analog Line			
<input type="checkbox"/> Analog Line					
<input type="checkbox"/> E1-R2 Line					
<input type="checkbox"/> IP DECT Line					
<input type="checkbox"/> SIP Line					
<input type="checkbox"/> SM Line					
<input type="checkbox"/> SIP DECT Line					
<input type="checkbox"/> IP Office Line					

Displaying 1 - 4 of 4

Back

## 8.3.8 Incoming Call Routes

This part of the dashboard wizard performs two actions:

- Define the days and times for a time profile called **Working Hours**. The default is 08:00 to 16:59 Monday to Friday.
- Select the destinations for the different incoming line group IDs, created through [line configuration](#)<sup>126</sup>, during and outside the hours defined by the time profile. One entry is shown for each different incoming line group. The destination for each can be set to any user or group extension number or to an auto-attendant name if embedded voicemail auto-attendants have been configured.

### Incoming Call Routes

Working hours Time Profile

Start Time  End Time

Sunday
  Monday
  Tuesday
  Wednesday
  Thursday
  Friday
  Saturday

Incoming Line Group ID	Trunk Identifier	Incoming Number	Working Hours Destination	Out Of Office Hours Destination
0	4 Analog Trunks		200 Main	200 Main

Create
Back

### 8.3.9 Outgoing Call Routes

This dashboard menu is only available on systems where the locale has been set to United States or Canada.

By default the configuration contains one **Automatic Route Selection** (ARS) entry call **Main**. All user dialing of external numbers is directed to that ARS entry to determine which lines should carry the outgoing calls (with all lines by default being in line group 0 and that line group used for all calls).

The dashboard wizard adds 3 additional ARS entries, called **Local**, **National** and **International** respectively.

#### OUTGOING CALL ROUTES

TELEPHONY SETTINGS

Directory Overrides Barring

YES

---

LINE SELECTION FOR OUTGOING CALLS

Select line for outgoing calls

Outgoing Group ID	Line Information
0	Analogue-5
0	Analogue-6
0	Analogue-7
0	Analogue-8

---

ASSIGN USERS TO OUTBOUND ROUTE

Name	Outgoing Route
RemoteManager	Main
NoUser	Main
Extn201	Main
Extn202	Main
Extn203	Main

- Directory Overrides Barring**  
If enabled, dialing (including speed dials and selection from a directory list) overrides outgoing call barring applied to the user when the number dialed matches a number in the system directory.
- Select line for outbound calls**  
When click the drop-down lists the available outgoing line group IDs created during [line configuration](#)<sup>126</sup>. The line group ID selected is applied to all the short codes in the new default ARS entries (**Local**, **National** and **International**) in the configuration.
- Assign Users to Outbound Route**  
By default each users outgoing calls are routed via the ARS entry Main (this is done by the system short code 9N). This list allows you to select for each users whether their calls should be routed using one of the other default ARS entries (**Local**, **National** or **International**). When a selection is made, a 9N short code with the appropriate ARS destination is added to the user's settings.

# Chapter 9.

# System Security

---

## 9. System Security

The IP Office system and its applications support a range of features for making links between them and users more secure. Full details of the options available are described in the [Avaya IP Office Platform Security Guidelines](#)<sup>11</sup> manual.

This section covers only some basic changes recommended to help make a new system more secure.

1. [Changing the Default Security Settings](#)<sup>131</sup>
2. [Changing the Remote User Password](#)<sup>132</sup>
3. [Disabling SIP Trunk Support](#)<sup>132</sup>
4. [Disabling H.323 Telephone Support](#)<sup>133</sup>
5. [Disabling SIP Extension Support](#)<sup>133</sup>
6. [Adding a Certificate](#)<sup>133</sup>



### Additional recommendations:

- If the network to which the IP Office is attached has external public Internet access, that access must be controlled by some additional security devices such as a Firewall and, for VoIP, a Session Border Controller (SBC).
- If LAN2 (the WAN port) is not being used, ensure that it is not connected to the network.



## 9.1 Changing the Default Security Settings

This process covers the minimal security changes required for the IP Office service run by the server. For full details of all the security settings, refer to the IP Office Manager help.

### To set/check the initial security configuration:

1. Using IP Office Manager, select **File | Advanced | Security Settings**. If the **Select IP Office Menu** does not appear, click .
2. Select the server and click **OK**. Enter the administrator user name and password.
3. For a system with default security settings, a number of warnings are displayed. Note each warning and click **OK**.
4. Select and change the following passwords:
  - a. **System Password**  
This password is used by IP Office Manager for system software upgrades. Click on the **Change** button and enter a new password. Click **OK**.
  - b. **Voicemail Password**  
This password is used by the Voicemail Pro server to connect to the IP Office system. When set, the same password also needs to be set in the voicemail server's preferences using the Voicemail Pro client.
  - c. **Monitor Password**  
This password is used by the System Monitor application to connect to the IP Office system using UDP or TCP. If not set, the **System Password** set above is used instead.
5. Select  **General**.
  - a. Enable **Block IP Phone Passcodes**. This stops H.323 and SIP IP phones being registered using passcodes such as 0000 or the same as the extension number.
  - b. Check the **IP Office User Details** section. This section defines what security rules are applied to the setting and use of user passwords (other than the voicemail password).
6. The **Application Controls** section indicates a number of unsecure interfaces used by the system. Deselect those that are not required by the planned customer applications. As you select or deselect the controls, the **Application Support** section below changes to show the effect of the change.

Application Control	Used by	Notes
<b>TFTP Server</b>	System Monitor	If disabled, in addition to disabling the other TFTP options below, the system cannot support the network viewer component in the System Monitor application.
<b>TFTP Directory Read</b>	IP DECT	If disabled, DECT operates without the system directory feature.
<b>TFTP Voicemail</b>	Voicemail Pro	–
<b>Program Code</b>	IP Office Manager	Used for upgrades from IP Office Manager, recommend disabling when not required.
<b>DevLink</b>	DevLink	–
<b>TAPI</b>	TAPI/DevLink	Disable unless the customer site will use TAPI applications with the IP Office.
<b>HTTP Directory Read</b>	one-X Portal for IP Office	–
<b>HTTP Directory Write</b>	one-X Portal for IP Office	–



7. Click **OK**.
8. Click  **Service Users**. By default, only the **Administrator** and **EnhTcpsaServer** users are enabled.
  - a. Select **EnhTcpsaService**. This service is used by one-X Portal for IP Office. If one-X Portal for IP Office is being installed, we recommend that the password is only changed after that installation is completed. If one-X Portal for IP Office is not being installed:
    - Click on the **Change** button and enter a new password for the service.
    - Click on **Account Status** and selected **Disabled**.
    - Click **OK**.
9. Click on the  icon to save the security changes.

---

## 9.2 Changing the Remote User Password

The configuration contains a user whose password is used as the default for remote dial in access to the IP Office network. The password of this user should be changed.

### To change the remote user password:

1. [Start IP Office Manager](#)  and connect to the IP Office system.
2. Click on  **Users** and in the list of users click on **Remote Manager**.
3. On the **User** tab, enter a new password for the user and click **OK**.
4. Click on the  icon and save the updated configuration back to the system.



## 9.3 Disabling SIP Trunk Support

The system supports SIP trunks. If these are not required for the customer installation, we recommend that the system's SIP trunk support is disabled.

### To disable SIP trunk support:

- **! WARNING**

The processes below require the IP Office system to reboot in order to apply any changes made. The reboot ends all current calls and services.

1. [Start IP Office Manager](#)  and receive the configuration from the IP Office system.
2. Select **System**.
3. Select **LAN1** and select the **VoIP** tab.
4. Check that **SIP Trunks Enable** is not selected.
5. Repeat the process for **LAN2**.
6. Click on the  save icon and save the updated configuration back to the system.

## 9.4 Disabling H.323 Telephone Support

The system supports H.323 IP telephones by default. If these are not required for the customer installation, we recommend that the system's H.323 telephone support is disabled.

### To disable H.323 telephone support:

- **! WARNING**

The processes below require the IP Office system to reboot in order to apply any changes made. The reboot ends all current calls and services.

1. [Start IP Office Manager](#)<sup>71</sup> and receive the configuration from the IP Office system.
2. Select **System**.
3. Select **LAN1** and select the **VoIP** tab.
4. Check that **H323 Gatekeeper Enable** is not selected.
5. Check that **H323 Remote Extn Enable** is not selected.
6. Repeat the process for **LAN2**.
7. Click on the  save icon and save the updated configuration back to the system.

## 9.5 Disabling SIP Extension Support

The system supports H.323 IP telephones by default. If these are not required for the customer installation, we recommend that the system's SIP telephone support is disabled.

### To disable SIP telephone support:

- **! WARNING**

The processes below require the IP Office system to reboot in order to apply any changes made. The reboot ends all current calls and services.

1. [Start IP Office Manager](#)<sup>71</sup> and receive the configuration from the IP Office system.
2. Select **System**.
3. Select **LAN1** and select the **VoIP** tab.
4. Check that **SIP Registrar Enable** is not selected.
5. Repeat the process for **LAN2**.
6. Click on the  save icon and save the updated configuration back to the system.

## 9.6 Adding a Certificate



For secure access to the server menus, the browser used requires the appropriate certificate.

- If using the server's own generated certificate, you can it using the following process.
- If using a certificate uploaded to the server, obtain a copy of the same certificate from the original source.

### To download the server certificate:

1. Login using IP Office Web Manager.
2. Select **Security | Certificates**.
3. Click **Export** and then click **Yes**.
4. The file is downloaded to your browser's normal location.

### To add a server security certificate to Firefox:

1. Click the  icon and select  **Options**. Alternatively, click on the  **Settings** icon if shown on the browser home page.
2. Click **Advanced** and select **Certificates**.
3. Click **View Certificates**.
4. Click **Authorities**.
5. Click **Import**. Browse to the location of the CRT or PEM file downloaded from the server. Select the file and click **Open**.

- 
6. Select all the check boxes to trust the certificate.
  7. Click **OK** twice.

**To add a server security certificate to Internet Explorer:**

1. Change the file extension from *.pem* to *.crt*.
2. Click **Tools** and select **Internet Options**.
3. Select the **Content** tab and click **Certificates**.
3. Click **Import**.
4. Click **Next** and **Browse** to the location of the downloaded certificate. Select it and click **Open**.
5. Click **Next**. Click **Place all certificates in the following store**.
  - If using the server's own generated certificate, select the **Trusted Root Certification Authorities**.
  - If using a certificate from another source, select **Intermediate Certification Authorities**.
6. Click **Next** and then **Finish**.
7. Click **OK, Close**.
8. Click **OK**.

### To add a server security certificate to Google Chrome:

1. Change the file extension from *.pem* to *.crt*.
2. Click the ☰ icon and select **Settings**.
3. Click **Advanced**. Scroll to **Privacy and security** and click **Manage certificates**.
3. Click **Import**.
4. Click **Next** and **Browse** to the location of the downloaded certificate. Select it and click **Open**.
5. Click **Next**. Click **Place all certificates in the following store**.
  - If using the server's own generated certificate, select the **Trusted Root Certification Authorities**.
  - If using a certificate from another source, select **Intermediate Certification Authorities**.
6. Click **Next** and then **Finish**.
7. Click **OK, Close**.

### To add a server security certificate to Mac Safari:

1. From the browser, open the directory containing the certificate file.
2. Double-click the certificate.
3. You are prompted to store the certificate in the **login keychain** or the **system keychain**. To make the certificate available to all users of this system, select **system keychain**.



# Chapter 10.

# SD Card Management

## 10. SD Card Management

The IP500 V2 control unit has two SD card slots, labeled **System SD** and **Optional SD** respectively. These are used as follows:

### • System SD Card

An Avaya System SD card must be present in this slot at all times. This card holds copies of the IP Office firmware and configuration.

- The card's unique ID number is used to validate any licenses used by the system. Note that this means all system licenses are tied to the particular SD card and not to the control unit.
- The card's ID number is printed on the card's label after **PLDS ID**, **FK SN** or **FK** depending on the age of the card. On newer cards is a 12-digit number. Older cards may have a 10-digit number. For PLDS licensing, use the 12-digit number. On older cards, for licensing, prefix the 10-digit number with **11**.
- If Embedded Voicemail is being used for voicemail, auto-attendants and announcements, the card stores the prompts for those services and acts as the message store for voicemail messages.
- Prior to any planned shutdown or restart of the system, the current configuration running in the system's RAM memory is copied to the **/primary** folder on the System SD card and to the system's non-volatile memory.
- Following a restart, the software in the **/primary** folder is loaded by the IP500 V2 control unit. If the required software is not present or valid a sequence of fallback options is used, see [Booting from the SD Cards](#)<sup>139</sup> for full details.
- Following a restart, if present, the configuration file in the **/primary** folder is loaded by the control unit. If no file is present, the system will check for a file in its internal non-volatile memory. If no copy is found, it generates a default configuration file. See [Booting from the SD Cards](#)<sup>139</sup> for full details.
- Once each day (approximately between 00:00 and 00:30), the system copies its current configuration from its RAM memory to the **/primary** folder on the card.
- Configuration changes made using IP Office Manager, are first written to the copy of the configuration file on the card, and then merged with the configuration running in the system's RAM memory.
- The write lock setting on the System SD card is ignored.

### • Optional SD Card

A card does not have to be present in this slot for normal operation. The slot can be used for various maintenance actions.

- A card with updated software or a configuration file can be inserted and those files then transferred to the System SD card. See [Backing Up to the Optional SD Card](#)<sup>146</sup>.
- The contents of the System SD card can be copied to the Optional SD card while the IP Office system is running. See [Loading Software from an Optional SD Card](#)<sup>148</sup>.
- The write lock setting on optional SD cards is honored.



#### Card Removal

SD cards should always be [shutdown](#)<sup>151</sup> before being removed from a running system. Though the card slot LED indicates when data is being written to an card, lack of flashing LED is not a sufficient safeguard. Shutting down the card disables Embedded Voicemail and IP Office Web Manager. If the **System SD** card is removed, features licensed by the card's serial number continue operating for up to 2 hours.

### Card Specification

Non-Avaya cards can be used in the **Optional SD** slot as long as they match or exceed the following specification:

- Only Avaya System SD can be used in the **System SD** slot:
  - Current Avaya SD cards are 8GB. The use of older 4GB cards is not recommended.
- Non-Avaya cards can be used in the **Optional SD** slot as long as they match or exceed the following specification:
  - SDHC 4GB minimum Class 2+. Single partition FAT32 format.
  - The card size should match or exceed that of the System SD card being used by the IP500 V2 control unit.

## 10.1 Booting from the SD Cards

When being powered up, the control unit looks for a valid ip500v2.bin binary file to load. It does this using the sources below in the order shown, skipping to the next source if the file is not present or is not valid.

1. System SD card **/primary** folder.
2. The control unit's own internal non-volatile memory. Once a system has been installed, it uses its non-volatile memory to keep copies of the configuration and system binary files it is using. These can be used to restore operation during a system reboot. Note that though a system can boot from non-volatile memory, a System SD card must still be present for correct system operation.
3. System SD card **/backup** folder.
4. Optional SD card **/primary** folder.
5. Optional SD card **/backup** folder.
6. If no file is found, the control unit falls back to making BOOTP requests to the network. IP Office Manager can respond the BOOTP request. See [Erasing the Operational Firmware](#)<sup>196</sup>.

Once a valid ip500v2.bin file is found, the IP Office control unit will load that firmware. The source from which the control unit binary file was loaded is then used to load further files.

### Configuration File Loading

Having installed the necessary system firmware files as above, the IP500 V2 control unit requires a configuration file:

- If the IP500 V2 booted using binary files from an SD card location, it looks for a valid configuration file in the same location.
  - If a configuration file is present and valid, it is loaded.
  - If a configuration file is present but is not valid, load the configuration copy in its non-volatile memory if present, else it assumes a default configuration.
  - If a configuration file is not present, use the non-volatile memory copy as above unless the reboot is as a result of a default system command.
- If the IP500 V2 booted using binary files from its non-volatile memory, it will also load the configuration copy from that location.
  - It will indicate a boot alarm (see below).
  - It will attempt to restore the firmware file in the System SD card's **/primary** folder using the copy in its non-volatile memory.
  - The normal boot up process of upgrading expansion module firmware does not occur. If the **File | Advanced | Upgrade** command is used, only external expansion modules actually present in the system are listed for upgrade.

### Post Boot Operation

During normal operation, configuration and binary files sent to the System SD card **/primary** folder using IP Office Manager are also written to the non-volatile memory.

If the system has booted from its non-volatile memory due to an SD card problem, it is still possible to upgrade the ip500v2.bin file using the IP Office upgrade wizard.

---

## Boot Alarms

The following apply if the IP500 V2 boots using software other than that in its System SD **/primary** folder:

- An alarm will be shown in the System Status Application. It will also generate an alarm if the card in any slot is not compatible. These alarms are also output as SNMP, Syslog or email alarms.
- The IP Office Manager **Select IP Office** menu will display an  icon, indicating that the IP Office system is running using software other than from the System SD card's primary folder.
- The configuration can be read but will be read only. Attempting to send a configuration to the system will cause the error message **Failed to save configuration data. (Internal error)**.

## Bypassing the System SD Card Primary Folder

The control unit can be forced to bypass the System SD card's **/primary** folder and non-volatile memory when starting. This is done by pressing the **Aux** button while applying power to the control unit.

This action may be necessary if, following an upgrade of the IP Office system, it is determined that a roll back to the previously backed up firmware and configuration is required. Using the **Aux** button should restore system operation using the **/backup** folder files while the installer then restores the contents of the **/primary** folder to a previous release.

## 10.2 Creating an IP Office SD Card

These processes can be applied to Avaya IP Office SD cards. They can also be applied to non-Avaya SD cards for use in a system's **Optional SD** card slot. For the **System SD** slot, only Avaya System SD cards should be used. The card must be the following format.

- Only Avaya System SD can be used in the **System SD** slot:
  - Current Avaya SD cards are 8GB. The use of older 4GB cards is not recommended.
- Non-Avaya cards can be used in the **Optional SD** slot as long as they match or exceed the following specification:
  - SDHC 4GB minimum Class 2+. Single partition FAT32 format.
  - The card size should match or exceed that of the System SD card being used by the IP500 V2 control unit.
-  **WARNING**  
Avaya supplied SD cards should not be formatted using any other method than the format commands within IP Office Manager and System Status Application. Formatting the cards using any other method removes the unique number used for validating IP Office licenses.
- **! Warning: IP Office Manager Version**  
These processes use files provided by the installed version of IP Office Manager being used. You must ensure that the version of IP Office Manager used matches the version of software required.
  - **Admin Lite Not Supported**  
Note that the IP Office Manager installed using the **AdminLite** installer is not the full version. It runs in English only and does not include the files needed for actions such as system upgrades, SD card recreation, etc. To fully support systems, ensure that you install the full IP Office Administration suite installer (approximately 1.52GB compared to the 230MB **AdminLite** installer).

### Creating a Card on a Local PC

These processes can be run on an SD card inserted in a card reader on the IP Office Manager PC. That card can then be used in the System SD card slot of a new system or in the Optional SD card slot of an existing system to upgrade that system.

### Formatting an SD Card

Avaya SD cards should only be formatted using the format options provided within IP Office Manager or System Status Application. Using any other application removes the unique ID used for license/subscription validation. This process is not normally necessary with Avaya SD cards unless you suspect that the card has been incorrectly formatted.

-  **WARNING: All File Will Be Erased**  
Note that this action will erase any existing files and folders on the card. Once a card has been formatted, the folders and files required for IP Office operation can be loaded onto the card from the IP Office Manager PC using the Recreate IP Office SD Card command.
1. Insert the SD card into a reader slot on the IP Office Manager computer.
  2. Using IP Office Manager, select **File | Advanced | Format IP Office SD Card**.
  3. Select **IP Office A-Law** or **IP Office U-Law**. This selection just sets the card label shown when viewing the card details. It does not affect the actual formatting. Select the label that matches the files set you will be placing on the card.
  4. Browse to the card location and click **OK**.
  5. The status bar at the bottom of IP Office Manager will display the progress of the formatting process.
  6. When the formatting is complete, you can use the **Recreate IP Office SD Card** command to load the IP Office folders and files onto the card from the IP Office Manager PC.

---

## Recreating an IP Office SD Card

You can use IP Office Manager to update the set of files on an System SD card to match those expected for the particular IP Office release. This can be used to upgrade the card from an existing system or to prepare the card for a new system.

IP Office Manager updates the card with the binary firmware files for the control unit, external expansion modules and phones. It also includes the prompt files for embedded voicemail operation and an option for the web manager application files.

Existing files such as the system configuration, PLDS license file and embedded voicemail messages and greetings are retained.

- For the card to be used in an control unit's **System SD** card slot it must be Avaya System SD card. The card must be correctly formatted (that can be done using IP Office Manager), however a reformat of an existing working card is not necessary before using recreate to update the card contents.
- The source for the files copied to the SD card are the sub-folders of the **\Memory Cards** folder under Manager's applications **Working Directory** (normally **C:\Program Files(x86)\Avaya\IP Office\Manager**). However, if the **Working Directory** is changed to a location without an appropriate set of **\Memory Cards** sub-folders, the required set of files will not be copied onto the SD card.

## Setting the Initial System Software Level

When the control unit makes its first call, the version of software it is running is written to a permanent record on the control unit. This becomes the base level of the control unit when considering the future requirements for upgrade. Therefore, for a new system it is important that you upgrade the System SD card to the required software version before starting the system.

## Determining the System SD card software level

On the SD card, in the **system/primary** folder, locate and open the **filelist.txt** file. The header section at the start of the file ends with the version of the set of files previously copied onto the card. The remainder of the file lists the actual files.

## To upgrade/recreate a System SD card

1. Once started do not interrupt this process, for example by removing the SD card. This process takes approximately 20 minutes.
2. Insert the SD card into a card reader on the IP Office Manager PC.
3. Using IP Office Manager, select **File | Advanced | Recreate IP Office SD Card**.
4. Select **IP Office A-Law** or **IP Office U-Law**. This selection affects how the IP Office systems operates when defaulted with this card present in its **System SD** card slot.
5. Browse to the card location and click **OK**.
6. IP Office Manager will prompt whether you want to include Avaya IP Office Web Manager files as part of the recreate process. Those files are necessary if you want to run [IP Office Web Manager](#)<sup>74</sup> to manage the IP Office system into which the card is loaded.
7. IP Office Manager will start creating folders on the SD card and copying the required files into those folders. This process will take approximately 20 minutes.
8. Do not remove the SD card during the process. Wait until the IP Office Manager displays the message *"System SD Card successfully recreated"*.

## 10.3 Viewing the Card Contents

Using IP Office Manager you can view the folders and files on the System SD card and the Optional SD card. You can then use various commands to upload and download files to and from the cards.

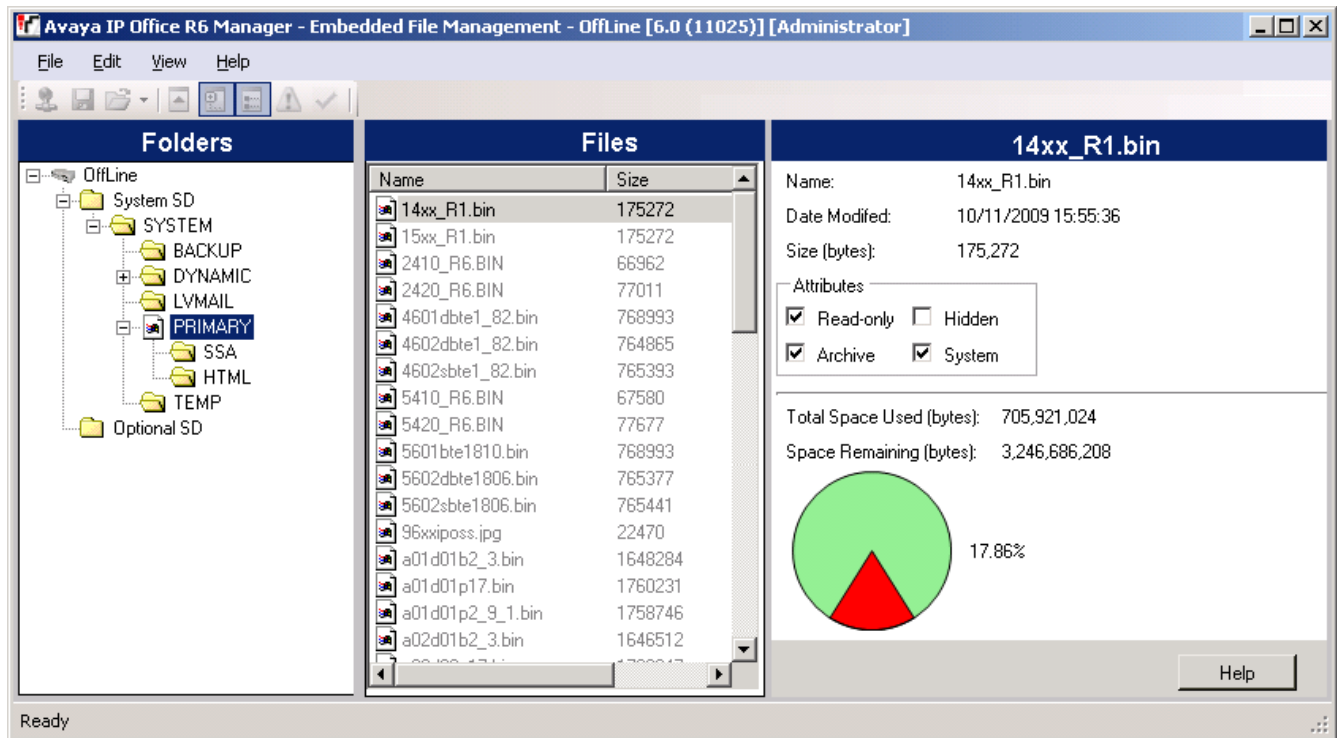

1. Using IP Office Manager, select **File | Advanced | Embedded File Management**.
2. Using the **Select IP Office** menu, select the IP Office system.
3. The file contents of the memory cards are displayed.

---

## 10.4 Backing Up to the Backup Folder

This process copies the contents of the **/primary** folder on the System SD card over the **/backup** folder on the same card. Any files with matching file names are replaced. This takes approximately 6 minutes. For methods to restore from the **/backup** folder see [Restore from the Backup Folder](#)<sup>145</sup>.

These processes do not backup the prompts, messages and greetings used by the system's voicemail mailboxes and auto attendants. They are stored in the card's **/lvmail** and **/dynamic/lvmail** folders.

### 10.4.1 Backup to the Backup Folder Using IP Office Manager

#### To backup to the **/backup** folder using IP Office Manager

1. Using IP Office Manager, select **File | Advanced | Embedded File Management**.
2. Using the **Select IP Office** menu, select the IP Office system.
3. The file contents of the memory cards are displayed.
4. Select **File | Backup System Files**.
  - The contents of the **/primary** folder on the System SD card will be copied to the **/backup** folder. This process takes approximately 6 minutes.

### 10.4.2 Backup to the Backup Folder Using System Status Application

#### To backup to the **/backup** folder using the System Status Application

1. Start [System Status](#)<sup>72</sup> and access the IP Office's status output.
2. In the navigation panel select **System**.
3. At the bottom of the screen select **Backup System Files**.
  - The contents of the **/primary** folder on the System SD card will be copied to the **/backup** folder. This process takes approximately 6 minutes.

### 10.4.3 Backup to the Backup Folder Using a System Phone

This process can be used by a user configured as a System Phone user and using a 1400, 1600, 9500 or 9600 Series phone (excluding XX01, XX02 and XX03 models). The user's **Login Code** is used to restrict access to the system administration functions on the phone.

#### To backup to the **/backup** folder using a System Phone

1. Select **Features | Phone User | System Admin**.
2. Enter your IP Office user login code.
3. From the menu select **Memory Card**.
4. Select **System Backup**.
  - The contents of the **/primary** folder on the System SD card will be copied to the **/backup** folder. This process takes approximately 6 minutes.

### 10.4.4 Backup to the Backup Folder Using a IP Office Web Manager

#### To backup to the **/backup** folder using IP Office Web Manager

1. Login to [IP Office Web Manager](#)<sup>74</sup>.
  - a. Enter the system's IP address in the browser. Select **IP Office Web Manager**. Alternatively, enter `https://<IP_Address>:8443/WebMgmtEE/WebManagement.html`.
  - b. Enter an administrator user name and password and click **Login**.
2. Click **Actions** and select **Backup**.
2. For the destination select **On Device**.
3. Click **Backup**.

## 10.5 Restoring from the Backup Folder

The contents of the **/backup** folder on the System SD card can be copied to the **/primary** folder on the same card. Any files with matching file names are replaced. The system then restarts using the files in the **/primary** folder.

- **! WARNING**

The processes below require the IP Office system to reboot in order to apply any changes made. The reboot ends all current calls and services.

### 10.5.1 Restoring from the Backup Folder Using IP Office Manager

1. Using IP Office Manager, select **File | Advanced | Embedded File Management**.
2. Using the **Select IP Office** menu, select the IP Office system.
3. The file contents of the memory cards are displayed.
4. Select **File | Restore System Files**.
  - The contents of the **/backup** folder on the System SD card are copied to the **/primary** folder. The process takes approximately 6 minutes.
  - When the process has been completed, the system restarts.

### 10.5.2 Restoring from the Backup Folder Using System Status Application

1. Start [System Status](#)<sup>72</sup> and access the IP Office's status output.
2. In the navigation panel select **System**.
3. At the bottom of the screen select **Restore System Files**.
  - The contents of the **/backup** folder on the System SD card are copied to the **/primary** folder. The process takes approximately 6 minutes.
  - When the process has been completed, the system restarts.

### 10.5.3 Restoring from the Backup Folder Using a System Phone

This process can be used by a user configured as a System Phone user and using a 1400, 1600, 9500 or 9600 Series phone (excluding XX01, XX02 and XX03 models). The user's **Login Code** is used to restrict access to the system administration functions on the phone.

#### To restore from the **/backup** folder using a System Phone

1. Select **Features | Phone User | System Admin**.
2. Enter your IP Office user login code.
3. From the menu select **Memory Card**.
4. Select **System Restore**.
  - The contents of the **/backup** folder on the System SD card are copied to the **/primary** folder. The process takes approximately 6 minutes.
  - When the process has been completed, the system restarts.

### 10.5.4 Restoring from the Backup Folder Using IP Office Web Manager

1. Login to [IP Office Web Manager](#)<sup>74</sup>.
  - a. Enter the system's IP address in the browser. Select **IP Office Web Manager**. Alternatively, enter `https://<IP_Address>:8443/WebMgmtEE/WebManagement.html`.
  - b. Enter an administrator user name and password and click **Login**.
2. Click **Actions** and select **Restore**.
2. For the destination select **On Device**.
3. Click **Restore**.

---

## 10.6 Backing Up to the Optional SD Card

This process copies all files on the System SD card to the Optional SD card. It includes the **/primary** and **/backup** folders and the Embedded Voicemail files including message files. Any matching files and folders on the Optional SD card are overwritten.

The process is a simple copy. Any files already copied that change while the process are not recopied. Any new files added while the process is running, for example voicemail messages, may not be copied.

This process takes at least 90 minutes and may take much longer depending on the amount of data to be copied, for example it will be longer if Embedded Voicemail is being used by the IP Office system to take messages.

### 10.6.1 Backing Up to the Optional SD Using IP Office Manager

#### To backup the System SD card to the Optional SD card using IP Office Manager

1. Using IP Office Manager, select **File | Advanced | Embedded File Management**.
2. Using the **Select IP Office** menu, select the IP Office system.
3. The file contents of the memory cards are displayed.
4. Select **File | Copy System Card**.
  - The contents of the System SD card will be copied to the Optional SD card. This process at least 90 minutes and can take much longer.

### 10.6.2 Backing Up to the Optional SD Using System Status Application

#### To backup the System SD card to the Optional SD card using System Status Application

1. Start [System Status](#)<sup>72</sup> and access the IP Office's status output.
2. In the navigation panel select **System**.
3. Select **Memory Cards**.
4. Select **System Card**.
5. At the bottom of the screen select **Copy System Card**.
  - The contents of the System SD card will be copied to the Optional SD card. This process at least 90 minutes and can take much longer.

### 10.6.3 Backing Up to the Optional SD Using IP Office Web Manager

#### To backup the System SD card to the Optional SD card using IP Office Web Manager

1. Login to [IP Office Web Manager](#)<sup>74</sup>.
  - a. Enter the system's IP address in the browser. Select **IP Office Web Manager**. Alternatively, enter `https://<IP_Address>:8443/WebMgmtEE/WebManagement.html`.
  - b. Enter an administrator user name and password and click **Login**.
2. Click **Actions**. Select **Service Commands** and select **Copy to Optional SD**.
3. Click **OK**.

### 10.6.4 Backing Up to the Optional SD Using a System Phone

This process can be used by a user configured as a System Phone user and using a 1400, 1600, 9500 or 9600 Series phone (excluding XX01, XX02 and XX03 models). The user's **Login Code** is used to restrict access to the system administration functions on the phone.

#### To backup the System SD card to the Optional SD card using a System Phone

1. Select **Features | Phone User | System Admin**.
2. Enter your IP Office user login code.
3. From the menu select **Memory Card**.
4. Select **Copy**.
  - The contents of the System SD card will be copied to the Optional SD card. This process at least 90 minutes and can take much longer.

## 10.7 Restoring a Configuration from an Optional Card

The following processes copy the configuration file (*config.cfg*) and licenses file (*PLDSkeys.xml*). The processes take a few seconds.

- **! WARNING**

The processes below require the IP Office system to reboot in order to apply any changes made. The reboot ends all current calls and services.

### 10.7.1 Restoring from the Optional SD Using IP Office Manager

#### To copy a configuration file from the Optional SD card using IP Office Manager

1. Using IP Office Manager, select **File | Advanced | Embedded File Management**.
2. Using the **Select IP Office** menu, select the IP Office system.
3. The file contents of the memory cards are displayed.
4. Select **File | Upgrade Configuration**.
  - The configuration file (*config.cfg*) and licenses file (*PLDSkeys.xml*) in the */primary* folder on the Optional SD card are copied to the */primary* folder on the System SD card. This process takes approximately a few seconds.
  - When the process has been completed, the IP Office system will be restarted.

### 10.7.2 Restoring from the Optional SD Using a System Phone

This process can be used by a user configured as a System Phone user and using a 1400, 1600, 9500 or 9600 Series phone (excluding XX01, XX02 and XX03 models). The user's **Login Code** is used to restrict access to the system administration functions on the phone.

#### To copy a configuration file from the Optional SD card using a System Phone

1. Select **Features | Phone User | System Admin**.
2. Enter your IP Office user login code.
3. From the menu select **Memory Card**.
4. Select **Upgrade Config...**
  - The configuration file (*config.cfg*) and licenses file (*PLDSkeys.xml*) in the */primary* folder on the Optional SD card are copied to the */primary* folder on the System SD card. This process takes approximately a few seconds.
  - When the process has been completed, the IP Office system will be restarted.

---

## 10.8 Loading Software from an Optional SD Card

These processes copy all files in the folder except the configuration file (**config.cfg**) and licenses file (**PLDSkeys.xml**).

The processes take approximately 5 minutes. These process do not restore Embedded Voicemail prompts (see [Upgrading Card Software](#)<sup>150</sup>).

- **! IP Office Technical Bulletins**

You must obtain and read the IP Office Technical Bulletin relating to the IP Office software release which intend to install. The bulletin contains important information that may not have been included in this manual. IP Office Technical Bulletins are available from the [Avaya support](http://support.avaya.com) website (<http://support.avaya.com>).

- **! WARNING**

The processes below require the IP Office system to reboot in order to apply any changes made. The reboot ends all current calls and services.

### 10.8.1 Loading Software from the Optional SD Using IP Office Manager

**To copy software files from the Optional SD card using IP Office Manager**

1. Using IP Office Manager, select **File | Advanced | Embedded File Management**.
2. Using the **Select IP Office** menu, select the IP Office system.
3. The file contents of the memory cards are displayed.
4. Select **File | Upgrade Binaries**.
  - The software files (all files in the folder except the configuration file (**config.cfg**) and licenses file (**PLDSkeys.xml**)) in the **/primary** folder on the Optional SD card are copied to the **/primary** folder on the System SD card. This process takes approximately 5 minutes.
  - When the process has been completed, the IP Office system will be restarted.

### 10.8.2 Loading Software from the Optional SD Using a System Phone

This process can be used by a user configured as a System Phone user and using a 1400, 1600, 9500 or 9600 Series phone (excluding XX01, XX02 and XX03 models). The user's **Login Code** is used to restrict access to the system administration functions on the phone.

**To copy software files from the Optional SD card using a System Phone**

1. Select **Features | Phone User | System Admin**.
2. Enter your IP Office user login code.
3. From the menu select **Memory Card**.
4. Select **Upgrade Binaries....**
  - The software files (all files in the folder except the configuration file (**config.cfg**) and licenses file (**PLDSkeys.xml**)) in the **/primary** folder on the Optional SD card are copied to the **/primary** folder on the System SD card. This process takes approximately 5 minutes.
  - When the process has been completed, the IP Office system will be restarted.

## 10.9 Backing Up to a PC

This process copies the **/backup** folder on the System SD card to a folder specified on the PC running IP Office Web Manager. This process takes approximately 25 minutes.

Before using this process, the contents of the **/Backup** folder can be updated with the files from the **/primary** folder on the same card. See [Backing Up to the Backup Folder](#)<sup>74</sup>.

### To backup to a PC using IP Office Web Manager

1. Login to [IP Office Web Manager](#)<sup>74</sup>.
  - a. Enter the system's IP address in the browser. Select **IP Office Web Manager**. Alternatively, enter `https://<IP_Address>:8443/WebMgmtEE/WebManagement.html`.
  - b. Enter an administrator user name and password and click **Login**.
2. Click **Actions** and select **Backup**.
3. For the destination select **Client Machine**.
4. Click **Configure Path**.
5. Select the location for the backup and click **Open**. We recommend that you create a new folder and then select that folder.
6. Click **Start Backup**.
7. Wait until a backup completed message is displayed. Click **Cancel** to close the menu.

## 10.10 Restoring from a PC

This process restores a previous backup, overwriting the **/primary** folder on the System SD card.

### • ! WARNING

The processes below require the IP Office system to reboot in order to apply any changes made. The reboot ends all current calls and services.

### To restore from a PC backup using IP Office Web Manager

1. Login to [IP Office Web Manager](#)<sup>74</sup>.
  - a. Enter the system's IP address in the browser. Select **IP Office Web Manager**. Alternatively, enter `https://<IP_Address>:8443/WebMgmtEE/WebManagement.html`.
  - b. Enter an administrator user name and password and click **Login**.
2. Click **Actions** and select **Restore**.
3. Click **Restore from** and select **Client Machine**.
4. Click **OK**.
5. Click **Configure Path**.
6. Select the folder containing the previous backup and click **Open**.
7. Click **Start Restore**.
8. Wait until a restore completed message is displayed. Click **Cancel** to close the menu. The system reboots.

## 10.11 Upgrading Card Software

In addition to using the traditional [IP Office Upgrade Wizard](#)<sup>178</sup>, IP500 V2 control units can be upgraded by loading the required set of firmware files onto the System SD card and rebooting the system.

- **! IP Office Technical Bulletins**

You must obtain and read the IP Office Technical Bulletin relating to the IP Office software release which intend to install. The bulletin contains important information that may not have been included in this manual. IP Office Technical Bulletins are available from the [Avaya support](http://support.avaya.com) website (<http://support.avaya.com>).

- **! WARNING**

The processes below require the IP Office system to reboot in order to apply any changes made. The reboot ends all current calls and services.

There are a number of ways in which this can be done.

Method	Description	Location	Software Files	Embedded Voicemail Prompts
<a href="#">System SD Card Upgrade</a> <sup>180</sup>	In this method, the System SD card is shut down and removed from the control unit. The card's contents are upgraded using IP Office Manager.	Local	✓	✓
<a href="#">Upgrade from Optional SD Card</a> <sup>181</sup>	This method uses an SD card loaded with the required version of IP Office software. The card is inserted into the control unit's Option SD card slot and its contents copied to the System SD card.	Local	✓	–

## 10.12 Memory Card Shutdown/Removal

Before a memory card is removed from an IP Office system that is running, the card must be shutdown. Removing a memory card while the system is running may cause file corruption. Card services can be restarted by either reinserting the card or using a [Start Up command](#)<sup>152</sup>.

### 10.12.1 Shutdown a Card Using IP Office Manager

#### To shutdown a memory card using IP Office Manager

1. Using IP Office Manager, select **File | Advanced | Memory Card Commands | Shutdown**.
2. Using the **Select IP Office** menu, select the IP Office system containing the memory card.
3. Click **OK**.
  - At the back of the control unit, confirm that the appropriate memory card LED is off.
  - The card can now be removed in order to perform the necessary maintenance actions.

### 10.12.2 Shutdown a Card Using System Status Application

#### To shutdown a memory card using System Status Application

1. Start [System Status](#)<sup>72</sup> and access the IP Office's status output.
2. In the navigation panel select **System**.
3. Select **Memory Cards**.
4. Select either **System Card** or **Optional Card**.
5. At the bottom of the screen select **Shutdown**.
  - At the back of the control unit, confirm that the appropriate memory card LED is off.
  - The card can now be removed in order to perform the necessary maintenance actions.

### 10.12.3 Shutdown a Card Using IP Office Web Manager

#### To shutdown a card using IP Office Web Manager

1. Login to [IP Office Web Manager](#)<sup>74</sup>.
  - a. Enter the system's IP address in the browser. Select **IP Office Web Manager**. Alternatively, enter `https://<IP_Address>:8443/WebMgmtEE/WebManagement.html`.
  - b. Enter an administrator user name and password and click **Login**.
2. Click **Actions**. Select **Service Commands** and select **Memory Card Stop**.
3. Select the card to stop and click **OK**.

### 10.12.4 Shutdown a Card Using a System Phone

This process can be used by a user configured as a System Phone user and using a 1400, 1600, 9500 or 9600 Series phone (excluding XX01, XX02 and XX03 models). The user's **Login Code** is used to restrict access to the system administration functions on the phone.

#### To shutdown a card using a System Phone

1. Select **Features | Phone User | System Admin**.
2. Enter your IP Office user login code.
3. From the menu select **Memory Card**.
4. Select **System** for the System SD card or **Option** for the Optional SD card.
5. Select **Shutdown**.
  - At the back of the control unit, confirm that the appropriate memory card LED is off.
  - The card can now be removed in order to perform the necessary maintenance actions.

---

## 10.13 Memory Card Startup

Reinserting a memory card into a system that is already switched on automatically restarts card operation. However, if the [card has been shutdown](#)<sup>151</sup> but not removed, it can be restarted using IP Office Manager without requiring a reboot.

### 10.13.1 Startup a Card Using IP Office Manager

#### To startup a card using IP Office Manager

1. Using IP Office Manager, select **File | Advanced | Memory Card Commands | Startup**.
2. Using the **Select IP Office** menu, select the IP Office system containing the memory card.
3. Click **OK**.

### 10.13.2 Startup a Card Using System Status Application

#### To startup a card using System Status Application

1. Start [System Status](#)<sup>72</sup> and access the IP Office's status output.
2. In the navigation panel select **System**.
3. Select **Memory Cards**.
4. Select either **System Card** or **Optional Card**.
5. At the bottom of the screen select **Start Up**.

### 10.13.3 Startup a Card Using IP Office Web Manager

#### To startup a card using IP Office Web Manager

1. Login to [IP Office Web Manager](#)<sup>74</sup>.
  - a. Enter the system's IP address in the browser. Select **IP Office Web Manager**. Alternatively, enter *https://<IP\_Address>:8443/WebMgmtEE/WebManagement.html*.
  - b. Enter an administrator user name and password and click **Login**.
2. Click **Actions**. Select **Service Commands** and select **Memory Card Start**.
3. Select the card to start and click **OK**.

### 10.13.4 Startup a Card Using a System Phone

This process can be used by a user configured as a System Phone user and using a 1400, 1600, 9500 or 9600 Series phone (excluding XX01, XX02 and XX03 models). The user's **Login Code** is used to restrict access to the system administration functions on the phone.

#### To startup a card using a System Phone

1. Select **Features | Phone User | System Admin**.
2. Enter your IP Office user login code.
3. From the menu select **Memory Card**.
4. Select **System** for the System SD card or **Option** for the Optional SD card.
5. Select **Startup**.

# Chapter 11.

## Additional Processes

---

# 11. Additional Processes

This section covers a range of maintenance processes.

## Processes

- [Adding the System Certificate to a Browser](#) <sup>155</sup>
- [Changing a System from IP Office Basic Edition Mode](#) <sup>157</sup>
- [Rerunning the Initial Configuration Utility](#) <sup>158</sup>
- [Automating the Change to Standard Mode](#) <sup>159</sup>
- [Saving the Configuration File Off-Line](#) <sup>160</sup>
- [Switching Off a System](#) <sup>161</sup>
- [Rebooting a System](#) <sup>163</sup>
- [Changing Components](#) <sup>164</sup>
- [Defaulting the Configuration](#) <sup>167</sup>
- [Defaulting Security Settings](#) <sup>170</sup>
- [Loading a Configuration](#) <sup>174</sup>
- [Upgrading systems](#) <sup>177</sup>
- [Swapping Extension Users](#) <sup>183</sup>
- [Out of Building Telephone Installations](#) <sup>36</sup>
- [Using the External Output Port](#) <sup>188</sup>
- [SNMP](#) <sup>189</sup>
- [Refreshing the System Files from Manager](#) <sup>193</sup>
- [Reset Button](#) <sup>194</sup>
- [AUX Button](#) <sup>194</sup>
- [RS232 Port Maintenance](#) <sup>195</sup>
- [Erasing the Core Software](#) <sup>196</sup>
- [Enabling IP Office Web Manager](#) <sup>199</sup>

## Other Processes

The following additional maintenance processes are covered in other sections of this document:

- [Creating an IP Office SD card](#) <sup>141</sup>
- [Viewing card contents](#) <sup>143</sup>
- [Backing up the configuration](#) <sup>144</sup>
- [Restoring the configuration](#) <sup>145</sup>
- [Copying to the Optional SD card](#) <sup>146</sup>
- [Restoring from the Optional SD card](#) <sup>147</sup>
- [Memory card shutdown/removal](#) <sup>151</sup>
- [Memory card startup](#) <sup>152</sup>
- [Installing the administration applications](#) <sup>68</sup>

## 11.1 Adding the System Certificate to a Browser



For secure access to the server menus, the browser used requires the appropriate certificate.

- If using the server's own generated certificate, you can it using the following process.
- If using a certificate uploaded to the server, obtain a copy of the same certificate from the original source.

### To download the server certificate:

1. Login using IP Office Web Manager.
2. Select **Security | Certificates**.
3. Click **Export** and then click **Yes**.
4. The file is downloaded to your browser's normal location.

### To add a server security certificate to Firefox:

1. Click the  icon and select  **Options**. Alternatively, click on the  **Settings** icon if shown on the browser home page.
2. Click **Advanced** and select **Certificates**.
3. Click **View Certificates**.
4. Click **Authorities**.
5. Click **Import**. Browse to the location of the CRT or PEM file downloaded from the server. Select the file and click **Open**.
6. Select all the check boxes to trust the certificate.
7. Click **OK** twice.

### To add a server security certificate to Internet Explorer:

1. Change the file extension from *.pem* to *.crt*.
2. Click **Tools** and select **Internet Options**.
3. Select the **Content** tab and click **Certificates**.
3. Click **Import**.
4. Click **Next** and **Browse** to the location of the downloaded certificate. Select it and click **Open**.
5. Click **Next**. Click **Place all certificates in the following store**.
  - If using the server's own generated certificate, select the **Trusted Root Certification Authorities**.
  - If using a certificate from another source, select **Intermediate Certification Authorities**.
6. Click **Next** and then **Finish**.
7. Click **OK, Close**.
8. Click **OK**.

---

### To add a server security certificate to Google Chrome:

1. Change the file extension from *.pem* to *.crt*.
2. Click the ☰ icon and select **Settings**.
3. Click **Advanced**. Scroll to **Privacy and security** and click **Manage certificates**.
3. Click **Import**.
4. Click **Next** and **Browse** to the location of the downloaded certificate. Select it and click **Open**.
5. Click **Next**. Click **Place all certificates in the following store**.
  - If using the server's own generated certificate, select the **Trusted Root Certification Authorities**.
  - If using a certificate from another source, select **Intermediate Certification Authorities**.
6. Click **Next** and then **Finish**.
7. Click **OK, Close**.

### To add a server security certificate to Mac Safari:

1. From the browser, open the directory containing the certificate file.
2. Double-click the certificate.
3. You are prompted to store the certificate in the **login keychain** or the **system keychain**. To make the certificate available to all users of this system, select **system keychain**.

## 11.2 Changing a System from IP Office Basic Edition Mode

The process below will change the mode of the system and default its configuration.

### To change a system from IP Office Basic Edition mode:

- **! WARNING**

The processes below require the IP Office system to reboot in order to apply any changes made. The reboot ends all current calls and services.

1. Using IP Office Manager, receive the [configuration from the system](#)<sup>71</sup>.
2. When requested, enter the service user name and password.
3. The IP Office Manager application automatically switches to its simplified view as the configuration is from a system running in IP Office Basic Edition mode.
4. Select **File | Advanced | Switch to Standard Mode (Default)**.
5. The configuration changes to a default one for a IP Office Essential Edition system and IP Office Manager switches to its advanced view mode.
6. This is a suitable time to begin [initial configuration](#)<sup>102</sup> before sending the configuration back to the IP Office system to restart in IP Office Essential Edition.
  - For a system to run in IP Office Essential Edition or IP Office Preferred Edition mode, its configuration must include an **Essential Edition** license. A system without this license will not allow any telephony functions until the license is added.
7. Once the system has rebooted, use IP Office Manager to again receive the configuration from the system. The user name and password for configuration should be the normal defaults **Administrator** and **Administrator**.

---

## 11.3 Rerunning the Initial Configuration Utility

You can rerun the initial configuration utility that is used for new systems.

### To rerun the initial configuration utility:

1. Using IP Office Manager or IP Office Web Manager, load the system configuration. Then either:
  - **Using IP Office Manager:**
    - a. Select **File | Advanced | Initial Configuration**.
    - b. The **Retain Configuration Settings** option controls whether the whole configuration should be defaulted or not.
    - c. Continue the initial configuration. See [Initial Configuration](#)<sup>105</sup> with Manager.
  - **Using IP Office Web Manager:**
    - a. Select **Solution | Actions | Initial Configuration**.
    - b. Select **Retain Configuration Settings** option controls whether the whole configuration should be defaulted or not.
    - c. Continue the initial configuration. See [Initial Configuration](#)<sup>115</sup> with Web Manager.

## 11.4 Automating the Change to Standard Mode

If the only systems that you install are ones using IP Office standard modes, IP Office Manager can be set to automatically default the system to IP Office standard mode.

- **! WARNING**

The processes below require the IP Office system to reboot in order to apply any changes made. The reboot ends all current calls and services.

1. In IP Office Manager, select **File | Preferences**.
2. On the **Preferences** sub-tab, enable **Default to Standard Mode**.

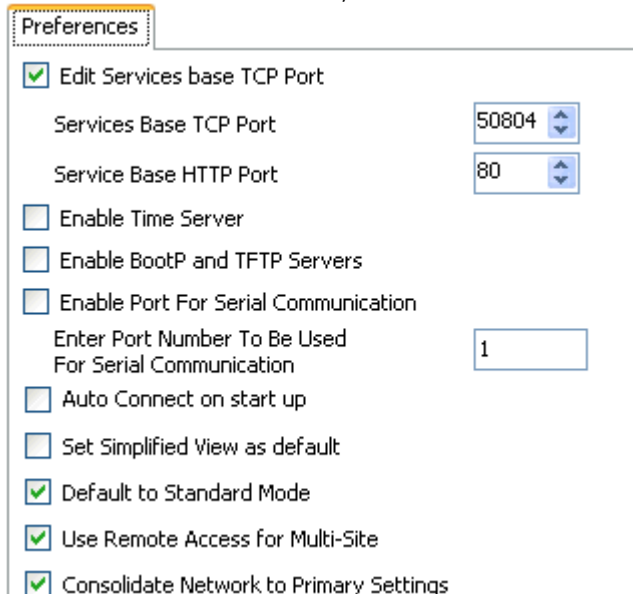

The screenshot shows the 'Preferences' dialog box in IP Office Manager. The 'Default to Standard Mode' checkbox is checked. Other settings include:

- Edit Services base TCP Port
  - Services Base TCP Port: 50804
  - Service Base HTTP Port: 80
- Enable Time Server
- Enable BootP and TFTP Servers
- Enable Port For Serial Communication
  - Enter Port Number To Be Used For Serial Communication: 1
- Auto Connect on start up
- Set Simplified View as default
- Default to Standard Mode
- Use Remote Access for Multi-Site
- Consolidate Network to Primary Settings

3. With this option enabled, when a configuration for a new or defaulted system running in IP Office Basic Edition is received by IP Office Manager, it will automatically be converted to a IP Office Essential Edition configuration.
4. **! Important: IP Address Settings Default to Server**  
The conversion will set the DHCP mode to **Server** and the LAN addresses to their defaults of 192.168.42.1 and 192.168.43.1. Using IP Office Manager to change these settings to the required values.
5. This is a suitable time to begin [initial configuration](#)<sup>102</sup> before sending the configuration back to the IP Office system to restart in IP Office Essential Edition.
  - For a system to run in IP Office Essential Edition or IP Office Preferred Edition mode, its configuration must include an **Essential Edition** license. A system without this license will not allow any telephony functions until the license is added.
6. Sending the configuration back to the system restarts the system in IP Office Essential Edition mode.

---

## 11.5 Saving the Configuration File Off-Line

The system holds multiple copies of its configuration file and will always try to restore the last working copy. For example, once a day (approximately between 00:00 and 00:30), the system copies its current configuration to the **/primary** folder on the System SD card.

Sometimes however, it may be necessary to obtain a copy of the system configuration file for other purposes. For example, it may be requested when reporting an issue.

- Note that the processes below are just for the system configuration file. They do not include other files being used by the system and files such as those used by Embedded Voicemail. For full backups see [Backing Up to the Backup Folder](#)<sup>144</sup> and [Backing Up to the Optional SD Card](#)<sup>146</sup>. These can then be used to restore the system if necessary.
- IP Office Manager can be configured to automatically save copies of the configuration file each time it is used to edit the configuration. Within IP Office Manager, look at the **File | Preferences | Security** settings and select **Help** for details.

### To download a copy of the system configuration file using IP Office Manager:

1. Login to IP Office Manager and load the system configuration.
2. Select **File | Save Configuration As**.
3. Save the file to a folder on your PC.

### To download a copy of the system configuration file using IP Office Web Manager:

1. Login to IP Office Web Manager and load the system configuration.
2. Select **Actions | Download Configuration**.
3. A copy of the system configuration is downloaded (the method and location of the download depend on the browser being used).

## 11.6 Switching Off a System

Systems must be shut down in order to perform maintenance rather than just switched off. The shut down can be either indefinite or for a set period of time after which the IP Office will automatically reboot. Note that the control unit memory cards can be [shutdown](#)<sup>161</sup> and [restarted](#)<sup>162</sup> separately from the system.

During the shut down process, the current configuration in the control unit's RAM memory is copied to the control units non-volatile memory. For IP500 V2 systems that location is the System SD card.

- **! WARNING**

A shutdown must always be used to switch off the system. Simply removing the power cord or switching off the power input may cause the loss of configuration data.

- This is not a polite shutdown, any user calls and services in operation will be stopped. Once shutdown, the system cannot be used to make or receive any calls until restarted.
- The shutdown process takes up to a minute to complete.

- **Shutdown LED Indication**

When shutdown, the LEDs shown on the system are as follows. Do not remove power from the system or remove any of the memory cards until the system is in this state:

- LED1 on each IP500 base card installed will also flash red rapidly plus LED 9 if a trunk daughter card is fitted to the base card.
- The CPU LED on the rear of the system will flash red rapidly.
- The System SD and Optional SD memory card LEDs on the rear of the system are extinguished.

- **Restarting a System**

To restart a system when shutdown indefinitely, or to restart a system before the timed restart expires, switch power to the system off and on again.

### Process Options

- [Shutdown a System Using IP Office Manager](#)<sup>161</sup>
- [Shutdown a System Using System Status Application](#)<sup>161</sup>
- [Shutdown a System Using a System Phone](#)<sup>162</sup>
- [Shutdown a System Using the AUX Button](#)<sup>162</sup>
- [Shutdown a System Using IP Office Web Manager](#)<sup>162</sup>

### 11.6.1 Shutdown a System Using IP Office Manager

#### To shutdown a system using IP Office Manager

1. Using IP Office Manager, select **File | Advanced | System Shutdown**.
2. Using the **Select IP Office** menu, the **System Shutdown Mode** menu is displayed.

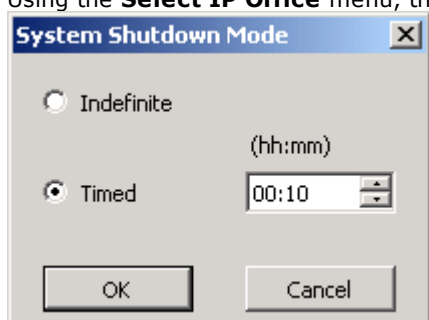

3. Select the type of shutdown required. If **Indefinite** is used, the system can only be restarted by having its power switched off and then on again. If a **Timed** shutdown is selected, the IP Office will reboot after the set time has elapsed.
4. Click **OK**.
5. Wait until the LEDs on the front of the system are all fast flashing red before performing any other actions.

### 11.6.2 Shutdown a System Using System Status Application

#### To shutdown a system using System Status Application

1. Start [System Status](#)<sup>72</sup> and access the IP Office's status output.

- 
2. In the navigation panel select **System**.
  3. At the bottom of the screen select **Shutdown System**.
  4. Select the time duration for the shutdown or indefinite.
  5. Click **OK**.
  6. Wait until the LEDs on the front of the system are all fast flashing red before performing any other actions.

### 11.6.3 Shutdown a System Using a System Phone

This process can be used by a user configured as a System Phone user and using a 1400, 1600, 9500 or 9600 Series phone (excluding XX01, XX02 and XX03 models). The user's **Login Code** is used to restrict access to the system administration functions on the phone.

Unlike IP Office Manager, a system phone user cannot select an indefinite shutdown. They can set a timed shutdown of between 5 minutes and 24 hours.

#### To shutdown a system using a system phone

1. Select **Features | Phone User | System Admin**.
2. Enter your IP Office user login code.
3. From the menu select **System Shutdown**.
4. Select a time period for the shutdown. It must be in between 5 minutes and 24 hours.
5. Press **Done** and then **Confirm** to begin the shutdown.
6. Wait until the LEDs on the front of the system are all fast flashing red before performing any other actions.

### 11.6.4 Shutdown a System Using the AUX Button

This method is supported by IP500 V2 control units.

#### To shutdown a system using the IP500 V2 AUX Button

1. On the rear of the control unit, press and hold the **AUX** button for more than 5 seconds.
2. The control unit will shutdown with the restart timer set to 10 minutes.
3. Wait until the LEDs on the front of the system are all fast flashing red before performing any other actions.

### 11.6.5 Shutdown a System Using IP Office Web Manager

#### To shutdown a system using IP Office Web Manager

1. Login to [IP Office Web Manager](#)<sup>74</sup>.
  - a. Enter the system's IP address in the browser. Select **IP Office Web Manager**. Alternatively, enter `https://<IP_Address>:8443/WebMgmtEE/WebManagement.html`.
  - b. Enter an administrator user name and password and click **Login**.
2. Click **Actions**. Select **Service Commands** and then **System Shutdown**.
3. Click **OK**.
4. Wait until the LEDs on the front of the system are all fast flashing red before performing any other actions.

## 11.7 Rebooting a System

It may occasionally be necessary to reboot the system. For example, after reinserting a System SD card with upgraded system software. That can be done using any of the following processes.

- **! WARNING**

One of the following methods should always be used to restart a system. Simply removing and then reapplying power to the system may cause the loss of data and unexpected system operation.

### Process Options

- [Reboot a System Using IP Office Manager](#)<sup>163</sup>
- [Reboot a System Using IP Office Web Manager](#)<sup>163</sup>
- [Reboot a System Using the Reset Button](#)<sup>164</sup>

### 11.7.1 Reboot a System Using IP Office Manager

#### To reboot a system using IP Office Manager

1. Using IP Office Manager, select **File | Advanced | Reboot**.
2. Use the **Select IP Office** menu to locate and select the IP Office system. Enter a valid user name and password.
3. The type of reboot can then be selected.
  - **Reboot**  
Select when the reboot should occur.
    - **Immediate**  
Reboot the system immediately.
    - **When Free**  
Reboot the system when there are no calls in progress. This mode can be combined with the **Call Barring** options.
    - **Timed**  
The same as When Free but waits for a specific time after which it then wait for there to be no calls in progress. The time is specified by the **Reboot Time**. This mode can be combined with the **Call Barring** options.
  - **Reboot Time**  
This setting is used when the reboot mode **Timed** is selected. It sets the time for the IP Office reboot. If the time is after midnight, the IP Office's normal daily backup is canceled.
  - **Call Barring**  
These settings can be used when the reboot mode when **When Free** is selected. They bar the sending or receiving of any new calls.
    - **! WARNING:** This option also bars the making of emergency calls. Therefore, it should be used with caution.
4. Click **OK**.

### 11.7.2 Reboot a System Using IP Office Web Manager

#### To reboot a system using IP Office Web Manager

1. Login to [IP Office Web Manager](#)<sup>74</sup>.
  - a. Enter the system's IP address in the browser. Select **IP Office Web Manager**. Alternatively, enter `https://<IP_Address>:8443/WebMgmtEE/WebManagement.html`.
  - b. Enter an administrator user name and password and click **Login**.
2. Click **Actions**. Select **Service Commands** and then **Reboot**.
3. Select when the reboot should occur:
  - **Immediate** - Reboot the system immediately.
  - **Free** - Reboot the system when there are no calls in progress.
  - **Timed** - Reboot the system at the set time.
4. Click **OK**.

---

## 11.7.3 Reboot a System Using the Reset Button

### To reboot a system using the Reset button

Use this process to reboot the system when free. Once invoked, the system bars any new incoming or outgoing calls until after the reboot.

1. On the rear of the control unit, press and hold the **Reset** button for between 5 to 10 seconds until the **CPU** led changes to steady orange.
2. When the **CPU** LED changes to steady orange, release the button.
  - If the **CPU** LED changed to flashing orange or red, keep the button held until the **CPU** LED changes to flashing green. Then release the button and reattempt the process once the CPU LED has returned to steady green.
3. Wait for the reboot to complete before performing any other actions.

## 11.8 Changing Components

In the sections below, the term component can refer to a card fitted into the IP Office or an external expansion module.

- **! IMPORTANT: You Must Switch Off the Control Unit Before Adding, Removing or Swapping Components**

Base cards, trunk cards and external expansions modules must only be removed and added to an IP Office system when that system is switched off<sup>161</sup>. Failure to do so will result in the new component not loading the correct firmware and not operating or not operating correctly. This applies even when swapping like for like components.

Note that for existing extension ports, by default both an extension entry and a user entry will exist in the IP Office configuration. Extension entries can be deleted without deleting the corresponding user entry. This allows retention of the user settings and association of the user with a different extension by changing that extensions **Base Extension** number to match the user's **Extension ID**.

### Processes

- [Like for Like Replacement](#)<sup>165</sup>
- [Higher Capacity Replacement](#)<sup>165</sup>
- [Lower Capacity Replacement](#)<sup>165</sup>
- [Adding a New Component](#)<sup>165</sup>
- [Permanent Removal](#)<sup>166</sup>
- [Replacement with a Different Type](#)<sup>166</sup>

### 11.8.1 Like for Like Replacement

If replacing with a component of the same type, no configuration changes are necessary.

#### To do a like for like replacement

1. [Shutdown the system](#)<sup>161</sup>.
2. Switch off power to the system.
3. Remove the card or external expansion module. Note the card slot or expansion port used as the replacement must be installed in the same position.
4. Install the replacement using the appropriate process for the type of component ([Fitting IP500 cards](#)<sup>84</sup>, [Adding External Expansion Modules](#)<sup>93</sup>).
5. Restart the IP Office system.

### 11.8.2 Higher Capacity Replacement

If replacing with a component of the same type but higher capacity, when restarted the IP Office will automatically create configuration entries for the new trunks or extensions/users.

#### To replace a component with one of the same type but higher capacity

1. [Shutdown the system](#)<sup>161</sup>.
2. Switch off power to the system.
3. Remove the card or external expansion module. Note the card slot or expansion port used as the replacement must be installed in the same position.
4. Install the replacement using the appropriate process for the type of component ([Fitting IP500 cards](#)<sup>84</sup>, [Adding External Expansion Modules](#)<sup>93</sup>).
5. Restart the IP Office system.
6. Use IP Office Manager to configure the new trunks or extensions/users.

### 11.8.3 Lower Capacity Replacement

If replacing with a component of the same type but lower capacity, after restarting the IP Office the configuration will need to be edited to remove redundant entries.

#### To replace a component with one of the same type but lower capacity

1. [Shutdown the system](#)<sup>161</sup>.
2. Switch off power to the system.
3. Remove the card or external expansion module. Note the card slot or expansion port used as the replacement must be installed in the same position.
4. Install the replacement using the appropriate process for the type of component ([Fitting IP500 cards](#)<sup>84</sup>, [Adding External Expansion Modules](#)<sup>93</sup>).
5. Restart the IP Office system.
6. Use IP Office Manager to delete the trunks or extensions/users that are no longer supported by the component installed.

### 11.8.4 Adding a New Component

If adding a new component to an available slot or port, when restarted the IP Office will automatically create configuration entries for the new trunks or extensions/users.

#### To add a new component

1. [Shutdown the system](#)<sup>161</sup>.
2. Switch off power to the system.
3. Install the replacement using the appropriate process for the type of component ([Fitting IP500 cards](#)<sup>84</sup>, [Adding External Expansion Modules](#)<sup>93</sup>).
4. Restart the IP Office system.
5. Use IP Office Manager to configure the new trunks or extensions/users.

---

## 11.8.5 Permanent Removal

If permanently removing the component, the configuration will need to be edited to remove redundant trunk or extension/user entries.

### To permanently remove a component

1. [Shutdown the system](#)<sup>161</sup>.
2. Switch off power to the system.
3. Remove the card or external expansion module.
4. Restart the IP Office system.
5. Use IP Office Manager to delete the trunks or extensions/users in the configuration that relate to the component removed.
6. In the **Control Unit** section of the configuration, delete the entry for the component that is no longer present in the system.

## 11.8.6 Replacement with a Different Type

If replacing a component with one of a different type, the process should be divided into two stages.

1. First remove the existing component using the [Permanent Removal](#)<sup>166</sup> process and adjust the configuration and reboot.
2. Then install the new component using the [Adding a New Component](#)<sup>165</sup> process.

## 11.9 Defaulting the Configuration

The following processes erases the configuration held in the control unit's memory. That include both the current configuration being used in RAM memory and the backup configuration stored in non-volatile memory. Following this, the system restarts with a default configuration.

This process should be performed from a PC with a fixed IP address, directly connected to the control unit and with the system disconnected from any network. Following this process, the control unit's IP address defaults to 192.168.42.1.

For IP Office Release 7.0 and higher, IP500 V2 systems using **IP Office A-Law** or **IP Office U-Law** System SD cards default to IP Office Basic Edition mode. Loading the configuration, switches IP Office Manager to simplified view. To change the system back, see [Changing the System from Basic Mode](#)<sup>165</sup>.

### Process Options

- [Defaulting the Configuration Using IP Office Manager](#)<sup>167</sup>
- [Defaulting the Configuration Using IP Office Web Manager](#)<sup>167</sup>
- [Defaulting the Configuration Using the Reset Button](#)<sup>167</sup>
- [Defaulting the Configuration Using Debug](#)<sup>168</sup>
- [Defaulting the Configuration Using Boot Loader](#)<sup>169</sup>

### 11.9.1 Defaulting the Configuration Using IP Office Manager

Read and note the warnings regarding [defaulting the configuration](#)<sup>167</sup> before using this process.

#### To erase the configuration using IP Office Manager

1. Start IP Office Manager.
2. Select **File | Advanced | Erase Configuration (Default)**.
3. Select the system to be defaulted and click **OK**.
4. Enter an administration name and password and click **OK**.

### 11.9.2 Defaulting the Configuration Using IP Office Web Manager

Read and note the warnings regarding [defaulting the configuration](#)<sup>167</sup> before using this process.

#### To default the configuration using IP Office Web Manager

1. Login to [IP Office Web Manager](#)<sup>74</sup>.
  - a. Enter the system's IP address in the browser. Select **IP Office Web Manager**. Alternatively, enter `https://<IP_Address>:8443/WebMgmtEE/WebManagement.html`.
  - b. Enter an administrator user name and password and click **Login**.
2. Click **Actions**. Select **Service Commands** and then **Erase Configuration**.
3. Click **OK**.
4. Wait until the system has rebooted before logging in again.

### 11.9.3 Defaulting the Configuration Using the Reset Button

Read and note the warnings regarding [defaulting the configuration](#)<sup>167</sup> before using this process.

#### To default the configuration using the Reset button

1. On the rear of the control unit, press and hold the **Reset** button for between 10 to 30 seconds until the **CPU** led changes to flashing orange.
2. When the **CPU** LED changes to flashing orange, release the button.
  - If the **CPU** LED changed to red, keep the button held until the **CPU** LED changes to flashing green. Then release the button and reattempt the process once the CPU LED has returned to steady green.
3. Wait for the reboot to complete before performing any other actions.

---

## 11.9.4 Defaulting the Configuration Using Debug

Read and note the warnings regarding [defaulting the configuration](#)<sup>167</sup> before using this process.

-  **WARNING**

Use of the RS232 port should only be performed if absolutely necessary and only if the actions cannot be completed using IP Office Manager or IP Office Web Manager. In all cases, you must make every effort to ensure that you have a backup copy of the system configuration.

### To erase the configuration using debug:

This process erases the IP Office's configuration settings but does not alter its security settings. It is easier to use than the boot loader method.

1. Ensure that you have a backup copy of the IP Office's configuration before performing this action. If a copy of the configuration cannot be downloaded using IP Office Manager, check the IP Office Manager application directory for previously downloaded configurations.
  - a. Use IP Office Manager to download an up to date copy of the configuration. If that is not possible, check in the IP Office Manager application folder for a previous copy of the configuration.
  - b. Using IP Office Manager, select **File | Open Configuration**.
  - c. Using the **Select IP Office Menu**, locate and select the IP Office system. Click **OK**.
  - d. Enter the name and password for a service user account on that IP Office. Click **OK**. IP Office Manager will receive and display the configuration from the IP Office.
    - If not already done, this action creates a BOOTP entry in IP Office Manager for the IP Office system.
    - This action also confirms communication between the IP Office Manager PC and the IP Office prior to any following process.
  - e. Select **File | Save Configuration As...** and save a copy of the configuration file onto the PC.
2. Attach the serial cable between the PC and the RS232 DTE port on the IP Office control unit.
  - a. Start the terminal program on your PC. Ensure that it has been setup as listed in [RS232 DTE Port Settings](#)<sup>268</sup>. Within a HyperTerminal session, the current settings are summarized across the base of the screen.
  - b. Enter **AT** (note upper case). The control unit should respond **OK**.
  - c. Enter **AT-DEBUG**. The control unit should response with the time and date and then **Hello>** to show it is ready to accept commands.
3. To erase the current configuration in RAM memory, enter **eraseconfig**. The **Hello>** command prompt reappears when the action is completed.
4. To erase the backup configuration stored in non-volatile Flash memory, enter **erasenvconfig**. The **Hello>** command prompt reappears when the action is completed.
5. To reboot the IP Office enter **reboot**. The IP Office will reboot and restart with a defaulted configuration.
6. Close the terminal program session.
7. IP Office Manager can now be used to alter and then upload an old configuration file or receive and edit the control unit's now defaulted configuration.

## 11.9.5 Defaulting the Configuration Using Boot Loader

Read and note the warnings regarding [defaulting the configuration](#)<sup>167</sup> before using this process.

-  **WARNING**

Use of the RS232 port should only be performed if absolutely necessary and only if the actions cannot be completed using IP Office Manager or IP Office Web Manager. In all cases, you must make every effort to ensure that you have a backup copy of the system configuration.

### To erase the configuration and security settings using the Boot Loader

This process also defaults the IP Office security settings.

1. Ensure that you have a backup copy of the IP Office's configuration before performing this action. If a copy of the configuration cannot be downloaded using IP Office Manager, check the IP Office Manager application directory for previously downloaded configurations.
  - a. Use IP Office Manager to download an up to date copy of the configuration. If that is not possible, check in the IP Office Manager application folder for a previous copy of the configuration.
  - b. Using IP Office Manager, select **File | Open Configuration**.
  - c. Using the **Select IP Office Menu**, locate and select the IP Office system. Click **OK**.
  - d. Enter the name and password for a service user account on that IP Office. Click **OK**. IP Office Manager will receive and display the configuration from the IP Office.
    - If not already done, this action creates a BOOTP entry in IP Office Manager for the IP Office system.
    - This action also confirms communication between the IP Office Manager PC and the IP Office prior to any following process.
  - e. Select **File | Save Configuration As...** and save a copy of the configuration file onto the PC.
2. Attach the serial cable between the PC and the RS232 DTE port on the IP Office control unit.
  - a. Start the terminal program on your PC. Ensure that it has been setup as listed in [RS232 DTE Port Settings](#)<sup>268</sup>. Within a HyperTerminal session, the current settings are summarized across the base of the screen.
  - b. Arrange the program windows so that the Terminal program and IP Office Manager TFTP Log are visible at the same time.
  - c. Switch off power to the IP Office control unit.
  - d. Power on the control unit and press the escape key every second until you get a Loader message. Below is an example.
 

```
P12 Loader 2.4
CPU Revision 0x0900
```
  - e. Enter **AT** (note upper case). The control unit should respond **OK**.
  - f. If an OK response is not received, check the settings of your terminal program and repeat the process above.
3. Proceed with the erasure process.
  - To erase the alarm log enter **AT-X1**.
  - To erase the current configuration, enter **AT-X2**. A typical response is **Sector 2 Erase (NV Config)** followed by **OK**. Enter **AT-X3**. A typical response is **Sector Erases (Config)** followed by a series of **OK** responses.
4. Switch power to the control unit off and then back on. Within the terminal program you should see various messages as the control unit performs various start up tasks.
5. Close the terminal program session.
6. IP Office Manager can now be used to alter and then upload an old configuration file or receive and edit the control unit's now defaulted configuration.

## 11.10 Defaulting Security Settings

If necessary, the security settings for access to the system can be defaulted. This includes resetting all the security service user accounts including those that are used by IP Office applications. Therefore, those application may need to be reconfigured to use the new service user accounts or account passwords.

Defaulting the system security settings does not affect user passwords, voicemail codes and login codes. However, the security settings includes rules for acceptable user passwords. Therefore, following a security default existing user passwords may be flagged as being in error.

Following the security default, the advice in the [Securing the System](#)<sup>130</sup> chapter should be followed. For details of the default security settings for a system refer to the IP Office Manager documentation.

- **! Warning - Service Disruption**

Whilst defaulting the security settings does not require a system reboot, it may cause service disruption for several minutes while the system generates a new default security certificate.

### Process Options

- [Defaulting Security Using IP Office Manager](#)<sup>171</sup>
- [Defaulting Security Using IP Office Web Manager](#)<sup>171</sup>
- [Defaulting Security using the RS232 Port](#)<sup>172</sup>
- [Defaulting Security Using the Boot Loader](#)<sup>173</sup>

### Logging in after defaulting the security settings:

When IP Office Manager connects to a system with default security settings, you are prompted to change the default passwords. This also applies if any one of the passwords is returned to the default value.

The screenshot shows a 'Change Password' dialog box with three sections: Administrator, Security Administrator, and System Password. Each section includes password requirements and input fields for 'New Password' and 'Re-Enter New Password'. The Administrator and Security Administrator sections require a minimum length of 8 characters and include uppercase, lowercase, numbers, and special characters. The System Password section requires a minimum length of 1 character and cannot be the same as the Administrator or Security Administrator passwords.

**Change Password - 000C2923ECCE - Administrator (Primary System - IPO-Linux-PC)**

**Administrator**

Minimum Password Length: 8.  
The password must include at least TWO of the following:  
Uppercase, Lowercase, Numbers, Special Character [# , \* , etc].  
Three or more repeated characters are not allowed.  
The password cannot be 'Administrator', 'securitypwd', or 'password'.

New Password:

Re-Enter New Password:

**Security Administrator**

Minimum Password Length: 8.  
The password must include at least TWO of the following:  
Uppercase, Lowercase, Numbers, Special Character [# , \* , etc].  
Three or more repeated characters are not allowed.  
The password cannot be 'Administrator', 'securitypwd', or 'password'.

New Password:

Re-Enter New Password:

**System Password**

Minimum Password Length: 1.  
The password cannot be 'Administrator', 'securitypwd', or 'password'.  
The password cannot be same as the Administrator or Security Administrator password being set.

New Password:

Re-Enter New Password:

OK Cancel

### 11.10.1 Defaulting Security Using IP Office Manager

Read and note the warnings regarding [defaulting the security settings](#)<sup>170</sup> before using this process.

- **! Warning - Service Disruption**

Whilst defaulting the security settings does not require a system reboot, it may cause service disruption for several minutes while the system generates a new default security certificate.

#### To default a system's security settings using IP Office Manager

1. Start IP Office Manager.
2. Select **File | Advanced | Erase Security Settings (Default)**.
3. Select the system from the menu and click **OK**.
4. Enter a name and password for security configuration access.
5. IP Office Manager indicates when the security settings have been reset.

### 11.10.2 Defaulting Security Using IP Office Web Manager

Read and note the warnings regarding [defaulting the security settings](#)<sup>170</sup> before using this process.

- **! Warning - Service Disruption**

Whilst defaulting the security settings does not require a system reboot, it may cause service disruption for several minutes while the system generates a new default security certificate.

#### To default a system's security settings using IP Office Web Manager

1. Login to [IP Office Web Manager](#)<sup>74</sup>.
  - a. Enter the system's IP address in the browser. Select **IP Office Web Manager**. Alternatively, enter `https://<IP_Address>:8443/WebMgmtEE/WebManagement.html`.
  - b. Enter an administrator user name and password and click **Login**.
2. Click **Actions**. Select **Service Commands** and then **Erase Security Settings**.
3. Click **OK**.

---

### 11.10.3 Defaulting Security using the RS232 Port

Read and note the warnings regarding [defaulting the security settings](#)<sup>170</sup> before using this process.

- **! Warning - Service Disruption**

Whilst defaulting the security settings does not require a system reboot, it may cause service disruption for several minutes while the system generates a new default security certificate.

-  **WARNING**

Use of the RS232 port should only be performed if absolutely necessary and only if the actions cannot be completed using IP Office Manager or IP Office Web Manager. In all cases, you must make every effort to ensure that you have a backup copy of the system configuration.

#### To default a system' security settings via DTE

This process defaults the IP Office's security settings but does not alter its configuration settings.

1. Attach the serial cable between the PC and the DTE port on the IP Office control unit.
2. Start the terminal program on your PC. Ensure that it has been setup as listed in [DTE Port Settings](#)<sup>268</sup>. Within a HyperTerminal session, the current settings are summarized across the base of the screen.
3. Enter **AT** (note upper case). The control unit should respond **OK**.
4. Enter **AT-SECURITYRESETALL**.
5. You will be prompted to confirm the control unit's MAC address before continuing. Enter the address.
6. After approximately a minute, the control unit will respond **OK** when the action has been completed.
7. Close the terminal program session.
8. IP Office Manager can now be used to receive and edit the control unit's now defaulted security settings.

## 11.10.4 Defaulting Security Using the Boot Loader

Read and note the warnings regarding [defaulting the security settings](#)<sup>170</sup> before using this process.

- **! Warning - Service Disruption**

Whilst defaulting the security settings does not require a system reboot, it may cause service disruption for several minutes while the system generates a new default security certificate.

- **⚠ WARNING**

Use of the RS232 port should only be performed if absolutely necessary and only if the actions cannot be completed using IP Office Manager or IP Office Web Manager. In all cases, you must make every effort to ensure that you have a backup copy of the system configuration.

### To default a system's security settings via Boot Loader

This process defaults the IP Office security settings and its configurations settings.

1. Ensure that you have a backup copy of the IP Office's configuration before performing this action. If a copy of the configuration cannot be downloaded using IP Office Manager, check the IP Office Manager application directory for previously downloaded configurations.
  - a. Use IP Office Manager to download an up to date copy of the configuration. If that is not possible, check in the IP Office Manager application folder for a previous copy of the configuration.
  - b. Using IP Office Manager, select **File | Open Configuration**.
  - c. Using the **Select IP Office Menu**, locate and select the IP Office system. Click **OK**.
  - d. Enter the name and password for a service user account on that IP Office. Click **OK**. IP Office Manager will receive and display the configuration from the IP Office.
    - If not already done, this action creates a BOOTP entry in IP Office Manager for the IP Office system.
    - This action also confirms communication between the IP Office Manager PC and the IP Office prior to any following process.
  - e. Select **File | Save Configuration As...** and save a copy of the configuration file onto the PC.
2. Attach the serial cable between the PC and the RS232 DTE port on the IP Office control unit.
  - a. Start the terminal program on your PC. Ensure that it has been setup as listed in [RS232 DTE Port Settings](#)<sup>268</sup>. Within a HyperTerminal session, the current settings are summarized across the base of the screen.
  - b. Arrange the program windows so that the Terminal program and IP Office Manager TFTP Log are visible at the same time.
  - c. Switch off power to the IP Office control unit.
  - d. Power on the control unit and press the escape key every second until you get a Loader message. Below is an example.
 

```
P12 Loader 2.4
CPU Revision 0x0900
```
  - e. Enter **AT** (note upper case). The control unit should respond **OK**.
  - f. If an OK response is not received, check the settings of your terminal program and repeat the process above.
3. To erase the current configuration in RAM memory enter **AT-X3**. A typical response is **Sector Erases (Config)** followed by a series of **OK** responses.
4. To erase the backup configuration stored in non-volatile memory enter **AT-X2**. A typical response is **Sector 2 Erase (NV Config)** followed by **OK**. IP Office 403 only: If running an IP Office 403 control unit, also enter **AT-X4**.
5. Switch power to the control unit off and then back on. Within the terminal program you should see various messages as the control unit performs various start up tasks.
6. Close the terminal program session.
7. IP Office Manager can now be used to alter and then upload an old configuration file or receive and edit the control unit's now defaulted configuration.





---

## 11.11 Loading a Configuration

The existing configuration of a system can be replaced with a new configuration that has been prepared separately.

- The configuration created must match the physical equipment in the IP Office system onto which it is loaded. Doing otherwise may cause the IP Office system to reset and experience other problems.

### Process Options

- [Creating an Offline Configuration File](#)  175
- [Loading a Configuration Using IP Office Manager](#)  176
- [Loading a Configuration Using IP Office Web Manager](#)  176
- [Loading a Configuration onto a System SD Card](#)  176

### 11.11.1 Creating an Offline Configuration File

IP Office Manager can be used to create a new configuration without connecting to an IP Office system. During the process, you can specify the locale of the system, what type of trunk cards it uses and what type of control unit and expansion modules to include.

This allows the creation of a configuration prior to installation of system. The configuration file can then be placed onto the System SD card before it is installed into the system. Otherwise the configuration can be uploaded to the system after initial installation of the system.

- The configuration created must match the physical equipment in the IP Office system onto which it is loaded. Doing otherwise may cause the IP Office system to reset and experience other problems.

#### To create an offline configuration file

1. Start IP Office Manager with no configuration loaded into IP Office Manager
2. Select **File | Offline | Create New Config**.

3. Select the type of configuration that you want to create. The equipment and settings are restricted to those supported in the selected mode.
4. When completed click **OK**.
5. IP Office Manager creates and loads the configuration.
6. Edit the configuration to match the customer requirements. This can include [importing information from pre-prepared CSV files](#)<sup>79</sup>.
  - Note that since this configuration is being done offline without licensing, you can configure features that may become unsupported once the configuration is loaded into the licensed system.
7. When completed, select **File | Save Configuration As**.
8. When prompted to enter a password to encrypt the file, leave the fields blank and click **OK**.

---

## 11.11.2 Loading a Configuration Using IP Office Manager

This process will replace the existing configuration.

- The configuration created must match the physical equipment in the IP Office system onto which it is loaded. Doing otherwise may cause the IP Office system to reset and experience other problems.

### To load an offline configuration using IP Office Manager

1. Start IP Office Manager.
2. Select **File | Offline | Open File...**
3. Select the configuration file and click **Open**.
4. Check that the configuration settings are as expected and make any adjustments necessary.
5. Select **File | Offline | Send Config...**
6. Select the system and click **OK**.
7. Enter an administrator name and password and click **OK**.
8. Select when the new configuration should be loaded. Do not select the **Merge** option.
9. Click **OK**.

## 11.11.3 Loading a Configuration Using IP Office Web Manager

This process will replace the existing configuration.

- The configuration created must match the physical equipment in the IP Office system onto which it is loaded. Doing otherwise may cause the IP Office system to reset and experience other problems.

### To load an offline configuration using IP Office Web Manager

1. Login to [IP Office Web Manager](#)<sup>74</sup>.
  - a. Enter the system's IP address in the browser. Select **IP Office Web Manager**. Alternatively, enter `https://<IP_Address>:8443/WebMgmtEE/WebManagement.html`.
  - b. Enter an administrator user name and password and click **Login**.
2. Click **Actions**. Select **Service Commands** and then **Upload Configuration**.
3. Click **Browse** and select the configuration file.
4. Click **Upload**.
5. Click **OK**.
6. Reboot the system for the new configuration to be applied fully. See [Rebooting a System](#)<sup>163</sup>.

## 11.11.4 Loading a Configuration onto a System SD Card

This process will replace the existing configuration.

- The configuration created must match the physical equipment in the IP Office system onto which it is loaded. Doing otherwise may cause the IP Office system to reset and experience other problems.

### To load a configuration directly onto a System SD card

1. Rename the offline configuration file as `config.cfg`.
2. Shutdown and remove the System SD card. See [Memory Card Shutdown/Removal](#)<sup>151</sup>.
3. Insert the SD card into the PC and display the card contents.
4. Open the `/system/primary` folder and replace the existing `config.cfg` file with the new file.
5. Reinsert the System SD card into the system.
6. Reboot the system. See [Rebooting a System](#)<sup>163</sup>.

## 11.12 Upgrading systems

There are several methods by which the system can be upgraded to a new release of IP Office core software.

### WARNINGS

- **! Warning: Upgrade License Requirements**

On a new system, when the first call is made, the software level being run is written into the control unit's permanent memory. Any subsequent upgrade to a higher release requires the addition of the **Essential Edition** license for the target release. Systems upgraded without that license display *"No license available"* on some phones and will not allow any telephony functions.

- **! Note: Server Edition Systems**

IP500 V2 control units configured as IP500 V2 Expansion System systems are licensed and upgraded through the Server Edition web management menus. Refer to the Server Edition documentation.

- **! WARNING: Upgrading pre-Release 9.1 Systems:**

Existing systems running a release lower than 8.1(65) must first upgrade to IP Office Release 8.1(65) (or higher 8.1) or any IP Office Release 9.0 before being upgraded to IP Office Release 9.1 or higher. For the lower releases, intermediate upgrade license are not required if the system is being further upgraded.

- **! WARNING: Upgrading pre-Release 10.0 Systems:**

IP Office Release 10 and higher does not support ADI licensing To upgrade a system that is using ADI licenses, those licenses must first be migrated to PLDS (unless the system is converted to an IP Office Subscription mode system in which case all existing licenses are lost).

- License migration is done by obtaining a license migration file using IP Office Manager (**Tools | License Migration**) and then submitting that file to Avaya. Note that this process also migrates any virtual licenses entitlements the system has to equivalent PLDS licenses but now associated with the feature key. Only upgrade the system once the replacement PLDS license file for the system has been obtained. Note that following license migration, Avaya will delete all records of any ADI license entitlements it holds for that feature key.

- **Check IP Office Technical Bulletins**

Check the latest IP Office Technical Bulletin for the IP Office software release before proceeding any further. It may contain information relating to changes that occurred after this document was completed. Bulletins are available from <http://support.avaya.com>.

- **! IP Office Web Manager**

The addition of IP Office Web Manager requires changes to the security settings of systems. For new systems those changes are made automatically. However, for system being upgraded, the changes can only be made if the system's security settings are defaulted. See [Enabling IP Office Web Manager](#)<sup>199</sup> for additional steps that should be performed before upgrading to IP Office Release 8.0 or higher.

- **Other IP Office Applications**

Upgrading the core software of the IP Office control unit will require upgrades to associated software. The levels of application software supported with the IP Office core are detailed in the IP Office Technical bulletin for the release.

- **DS16B/DS30B Upgrade Behavior:**

For DS16B/DS30B modules, the process of loading the appropriate firmware for the selected mode or upgrading takes up to 10 minutes during which time the module is not available.

- **DS16B2/DS30B2 Upgrade Behavior:**

The behavior of DS16/30B2 during firmware upgrade or switching modes differs from other external expansion units:

- During the firmware upgrade, the unit remains operational and can make and receive calls.
- Once the upgrade is completed (approximately 9 minutes) the unit reboots and takes about 45 seconds to return to normal operation.

- **! Warning: IP Office Manager Version**

These processes use files provided by the installed version of IP Office Manager being used. You must ensure that the version of IP Office Manager used matches the version of software required.

- **Admin Lite Not Supported**

Note that the IP Office Manager installed using the **AdminLite** installer is not the full version. It runs in English only and does not include the files needed for actions such as system upgrades, SD card recreation, etc. To fully support systems, ensure that you install the full IP Office Administration suite installer (approximately 1.52GB compared to the 230MB **AdminLite** installer).

---

## 11.12.1 Upgrade Using the Upgrade Wizard

The Upgrade Wizard is part of IP Office Manager. It can be used to upgrade multiple system's at the same time.

- **! WARNING:** You must read and understand all [upgrade pre-requisites](#) before upgrading any system.

### To upgrade systems using the upgrade wizard

1. Ensure that you have a backup copy of the IP Office's configuration before performing this action. If a copy of the configuration cannot be downloaded using IP Office Manager, check the IP Office Manager application directory for previously downloaded configurations.
  - a. Use IP Office Manager to download an up to date copy of the configuration. If that is not possible, check in the IP Office Manager application folder for a previous copy of the configuration.
  - b. Using IP Office Manager, select **File | Open Configuration**.
  - c. Using the **Select IP Office Menu**, locate and select the IP Office system. Click **OK**.
  - d. Enter the name and password for a service user account on that IP Office. Click **OK**. IP Office Manager will receive and display the configuration from the IP Office.
    - If not already done, this action creates a BOOTP entry in IP Office Manager for the IP Office system.
    - This action also confirms communication between the IP Office Manager PC and the IP Office prior to any following process.
  - e. Select **File | Save Configuration As...** and save a copy of the configuration file onto the PC.
2. Select **File | Advanced | Upgrade**. The UpgradeWiz is started and scans for IP Office modules using the **Unit/Broadcast** address. Adjust this address and click **Refresh** if the expected control units are not shown. The current version of each IP Office BIN file held in the control units memory is shown. That is regardless of whether that .bin file is currently being used by any module in the system.
3. The **Version** column indicates the current version of software installed. The **Available** column indicates the version of software IP Office Manager has available. If the available version is higher, the check box next to that row is automatically selected.
  - If any of the modules have pre-version 2.1 software installed, an upgrade with **Validate** unticked is required. If this is the case, only continue with the upgrade process using a PC with a fixed IP address on the same LAN domain and physical LAN segment as the IP Office control unit and only upgrade the pre-2.1 system.
  - If a multi-stage upgrade is necessary, use the following additional steps to select the appropriate interim software:
    - Right-click on the upgrade wizard and click **Select Directory**. Locate and select the directory containing the bin file for the intermediate software level.
    - The upgrade wizard should now list just the control unit as having upgrade software available.
  - Upgrading to particular levels of IP Office 10.0 or higher software requires the appropriate Essential Edition license for the release. The **Licensed** and **Required License** columns indicate the current license entitlement and the required license entitlement [for the software the system is currently running](#).
4. For those modules which you want to upgrade, tick the check box.
5. The following additional options are available:
  - **Backup System Files**  
If selected, before upgrading to the new software, the current files in the System SD cards **/primary** folder are be copied to its **/backup** folder. If there is insufficient space on the SD card for this action, IP Office Manager displays an *"Insufficient space available on SD Card"* warning.
  - **Upload System Files**  
If selected, the full set of software files that IP Office Manager has is copied to the **/primary** folder on the System SD card. In addition to control unit and module software this includes phone software files and the files used for IP Office Web Manager. The firmware files for Avaya IP phones are uploaded first and when this is completed, if **Restart IP Phones** below is also selected, the Avaya IP phones are rebooted. The system then continues to upload any other files. If there is insufficient space on the SD card for this action, IP Office Manager displays an *"Insufficient space available on SD Card"* warning.
  - **Restart IP Phones**  
This option is available if **Upload System Files** above is also selected. If selected, once the system has rebooted and uploaded the phone firmware files, it reboots the IP phones. This causes them to reload the settings files and to recheck whether the firmware they currently have loaded matches that now available from their configured file server (by default the IP Office system). When selected, after the system reboot, the phones display *"Upgrading from system"* until restarted by the system once it has uploaded the phone firmware files.

6. Select **Upgrade**. The system password for each system will be requested. Enter it and click **OK**. The next steps depend on the upgrade options selected. Do not cancel or close the upgrade wizard while these processes are running.
  - **Insufficient space available on SD card**

This message appears if the System SD card has insufficient space. To proceed with a reliable upgrade the SD card should [upgraded locally](#)<sup>180</sup>.
  - **Validated Upgrade**

If using the **Validated** option, a number of actions take place as follows;

    - a. The upgrade wizard checks the amount of free RAM memory available in the control unit to temporarily store the new BIN files. If insufficient memory is available, you will be prompted whether to continue with an off-line upgrade or cancel upgrading.
      - If offline is selected, the IP Office is rebooted into offline mode. It may be necessary to use the **Refresh** option within the Upgrade Wizard to reconnect following the reboot. Validate upgrade can then be attempted to again check the amount of available RAM memory for transfer of BIN files. If the memory is still insufficient, the option is offered to either do an unvalidated upgrade or cancel.
    - b. The bin files required are transferred to the system and stored in temporary memory.
    - c. The backup system files and upload system files actions are performed if they were selected.
    - d. Once all file transfers are completed, the upgrade wizard will prompt whether it okay to proceed with the upgrade process. Select **Yes** to continue. The control unit reboots and upgrades itself first. It then proceeds with upgrading the external expansion modules.
  - **Unvalidated Upgrade**

This method of upgrading should be avoided unless absolutely necessary. It is only required for IP Office systems with pre-2.1 software and should only be done from a IP Office Manager PC with a fixed IP address running on the same LAN segment and subnet as the IP Office system. During the upgrade, the units and modules erases their current software and then request the new software file from IP Office Manager.
7. Following the upgrade, check that the upgrade wizard now shows that the selected units and modules have upgraded. It may be necessary to select **Refresh** to update the information in the upgrade wizard display.
8. Repeat the process as required.

---

## 11.12.2 Locally Upgrade the SD System Card Using Manager

The following process can be used if you have physical access to the IP500 V2 control unit. This method can be used with a timed reboot, allowing the card upgrade to be done during normal operation hours followed by a reboot outside of normal operation hours.

If the card is being used for Embedded Voicemail, that service is not available while the card is shutdown. Licensed features will continue running for up to 2 hours whilst the card is shutdown.

- **! WARNING:** You must read and understand all [upgrade pre-requisites](#)<sup>177</sup> before upgrading any system.

### To upgrade a System SD Card using a PC

1. [Shutdown the System SD memory card](#)<sup>151</sup> and remove it from the control unit.
2. Follow the process for [recreating the SD card](#)<sup>141</sup>. This process will overwrite the software files on the card with the files available to IP Office Manager. This process takes approximately 20 minutes.
  - The process does not affect any current configuration file, Embedded Voicemail announcements and messages, or temporary SMDR data files.
  - The process deletes any current PLDS license file. The file needs to be restored after the SD card is recreated.
3. When the recreate process has completed, reinsert the card into the control unit's **System SD** card slot.
4. Using IP Office Manager select **File | Advanced | Reboot**.
5. In the **Select IP Office** menu, select the IP500 V2 system and click **OK**.
6. Select the type of reboot that you want performed and click **OK**.
7. When the system is rebooted, as it restarts it will load the software files in the primary folder of the System SD card.

### 11.12.3 Upgrading Using an Optional SD Card

The PC running IP Office Manager can be used to load the full set of operation files onto an SD card. This includes the firmware for the core system, phone firmware files and files for embedded voicemail. If the card contains configuration, message and prompt files, those files are not deleted by this process.

- **! WARNING:** You must read and understand all [upgrade pre-requisites](#)<sup>177</sup> before upgrading any system.

#### Upgrade by Updating an Optional SD Card

1. Shutdown the Optional SD card and remove the card from the system. See [Memory Card Shutdown/Removal](#)<sup>151</sup>.
2. Follow the process for [recreating the SD card](#)<sup>141</sup>. This process will overwrite the software files on the card with the files available to IP Office Manager. This process takes approximately 20 minutes.
3. Reinsert the card into the Optional SD card slot on the system.
4. Copy the files from the Optional SD card to the System SD card. See [Loading Software from an Optional SD Card](#)<sup>148</sup>.
5. Reboot the system. See [Rebooting a System](#)<sup>163</sup>.

---

## 11.12.4 Upgrading Using IP Office Web Manager

Avaya may make upgrade packages available for use with IP Office Web Manager. Once unpacked onto a local PC, the process below can be used to upgrade the system.

- **! WARNING:** You must read and understand all [upgrade pre-requisites](#)<sup>177</sup> before upgrading any system.

### To upgrade a system using IP Office Web Manager

1. Login to [IP Office Web Manager](#)<sup>74</sup>.
  - a. Enter the system's IP address in the browser. Select **IP Office Web Manager**. Alternatively, enter *https://<IP\_Address>:8443/WebMgmtEE/WebManagement.html*.
  - b. Enter an administrator user name and password and click **Login**.
2. Unpack the upgrade files to a location on your client PC.
3. Click **Actions** and select **Upgrade**.
4. Click **Configure Path**.
5. Select the folder containing the unpacked upgrade files and click **Open**.
6. Click **Start Upgrade**.

## 11.13 Swapping Extension Users

Whilst the example below shows 2 users swapping extensions the method can be used to swap multiple users within the configuration and effecting the swaps after a single merge of the configuration changes.

### Swapping Extension Users

For this example User A (202) and User B (203) want to swap extensions.

1. Load the IP Office configuration and select  **Extension**.
2. Locate the extension with the **Base Extension** set to **202**, ie. matching User A's extension number.
  - If the group pane is visible (**View | Group Pane**) in IP Office Manager, it shows the extension details (ID, Module, Port and Base Extension).

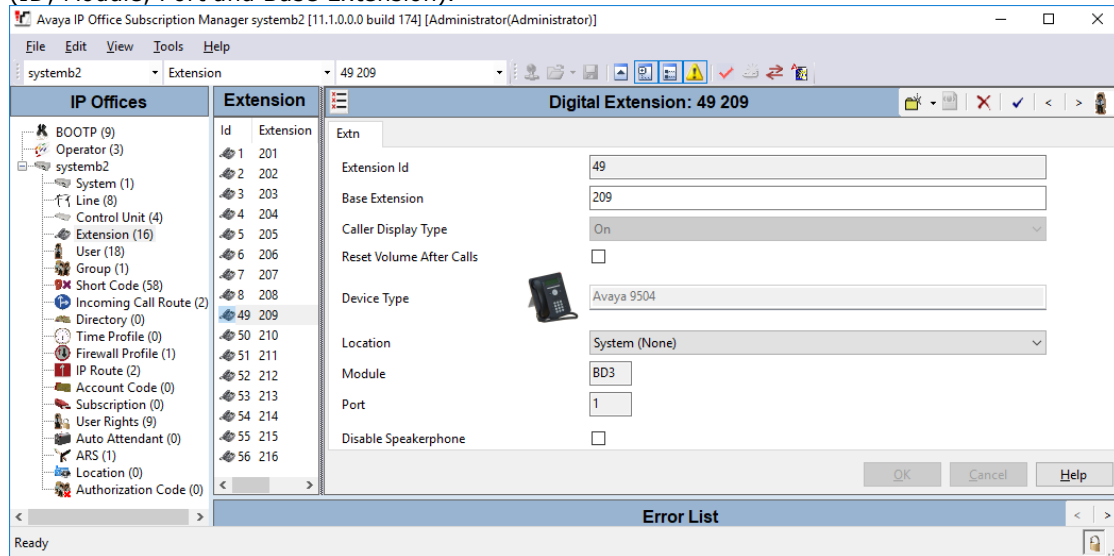

3. Select that extension and change its **Base Extension** setting to **203**, ie. to now match User B's extension number. If IP Office Manager is set to validate edits, it will warn that this change conflicts with the existing Base Extension setting of another extension. Ignore the warning at this stage. Click **OK**.
4. Locate the other extension with the **Base Extension** set to **203**, ie. matching User B's extension number.
5. Select that extension and change its **Base Extension** setting to **202**, ie. to now match User A's extension number. If the error pane is visible (**View | Error Pane**), the warnings about extension conflicts should now disappear. Click **OK**.
6. Save the configuration back to the IP Office system.
7. At each of the extensions dial the log out short code set on the IP Office system. By default this is **\*36**.
  - If any of the users is set to **Forced Login**, they will have to complete the login process at their new extension using their Login Code.

## 11.14 Out of Building Telephone Installations

The following are the only supported scenarios in which wired extensions and devices outside the main building can be connected to the IP Office system. In these scenarios, additional protection, in the form of protective grounding and surge protectors, must be fitted.

- ⚠ **WARNING**  
 The fitting of additional protection does not remove the risk of damage. It merely reduces the chances of damage.

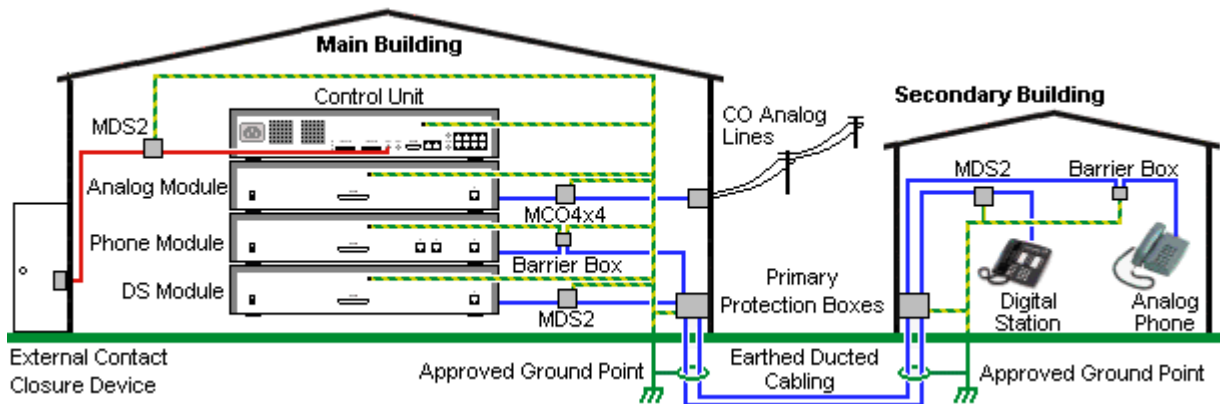

- Only ports on IP Office external expansion modules are supported. Out-of-building connection to ports on base cards in the control unit is not supported.
- Cables of different types, for example trunk lines, phone extensions, ground and power connections, should be kept separate.
- All cabling between buildings should be enclosed in grounded ducting. Ideally this ducting should be buried.
- A Primary Protection Box must be provided at the point where the cables enter the building. This should be three point protection (tip, ring and ground). Typically this would be gas tube protection provided by the local telephone company. The ground wire must be thick enough to handle all the lines being affected by indirect strike at the same time.

Connection Type	Protection Device Type	Requirement
<b>Analog Phone Extensions</b> Phones External expansion module (POT <sup>266</sup> or PHONE <sup>266</sup> ) ports only.	<b>IP Office Barrier Box</b> <sup>185</sup> Supports a single connection. Maximum of 16 on any expansion module.	<ul style="list-style-type: none"> <li>Connection from the external expansion module to the phone must be via a surge protector at each end and via the primary protection point in each building.</li> <li>The IP Office external expansion modules, control unit and IROB devices must be connected to the protective ground point in their building.</li> <li>The between building connection must be via earthed ducting, preferable underground. The cable must not be exposed externally at any point.</li> </ul>
<b>DS Phone Extensions</b>	<b>ITW Linx MDS2</b> <sup>185</sup> Supports up to 4 connections. This device was previously referred to as the Avaya 146E.	
<b>Analog Trunks</b>	<b>ITW Linx MCO4x4</b> <sup>185</sup> Supports up to 4 two-wire lines. This device was previously referred to as the Avaya 146C.	For installations in the Republic of South Africa, the fitting of surge protection on analog trunks is a requirement.  For other locations where the risk of lightning strikes is felt to be high, additional protection of incoming analog trunks is recommended.
<b>External Output Switch</b>	<b>ITW Linx MDS2</b> <sup>185</sup> Supports up to 4 connections. This device was previously referred to as the Avaya 146E.	Connections from an IP Office Ext O/P port to an external relay device must be via a surge protector.  When using the MDS2 on the Ext O/P port, use only the Line 1 and Equipment 1 jacks, do not use the Line 2 or Equipment 2 jacks.

The towerMAX range of devices are supplied by ITWLinx (<http://www.itwlinx.com>).



### 11.14.1 DS Phones

When digital phone extensions are required in another building, additional In-Range Out-Of-Building (IROB) protective equipment must be used. For phones connected to IP Office **DS** ports, the supported device supplied by ITWLinx is a towerMAX DS/2 module. This IROB device was previously badged by Avaya as the 146E IROB.

The protection device should be installed as per the instructions supplied with the device. The ground points on the IP Office control unit and any external expansion modules must be connected to a protective ground using 18AWG wire with a green and yellow sleeve.

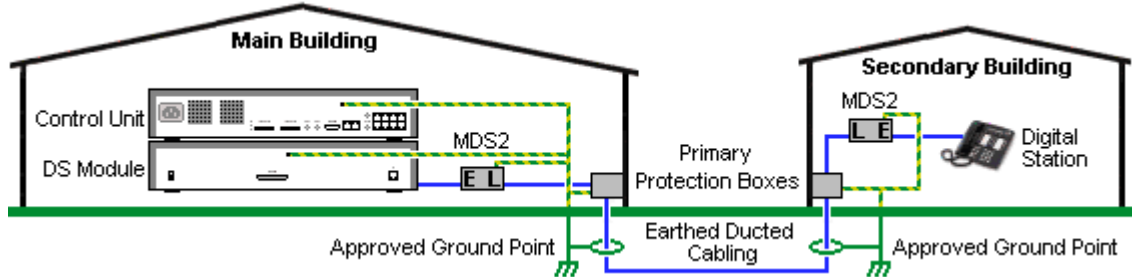
Typically the IROBs 2 RJ45 EQUIPMENT ports are straight through connected to the 2 RJ45 LINE ports. This allows existing RJ45 structured cabling, using pins 4 and 5, to be used without rewiring for up to two DS connections. However, each of these ports can be used to connect a second extension using pins 3 and 6.

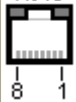

LINE		Signal	EQUIPMENT	
 8 1	1	Not used.	 8 1	1
	2	Not used.		2
	3	Ring II (Optional)		3
	4	Ring I		4
	5	Tip I		5
	6	Tip II (Optional)		6
	7	Not used.		7
	8	Not used.		8

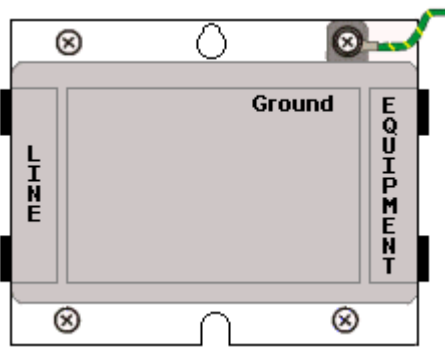

## 11.14.2 Analog Phone Barrier Box

Where analog phone extensions are required in another building, additional protective equipment must be used, in the form of IP Office Phone Barrier Boxes and protective earth connections.

- CAUTION**  
 PHONE (POT) ports on the front of control units must not be used for extensions that are external to the main building.
- The correct IP Office specific barrier boxes must be used. These modules have been designed specifically for the signalling voltages used by the IP Office system:
  - Only the IP Office Phone Barrier Box should be used with Phone V1 modules.
  - Only the IP Office Phone Barrier Box V2 should be used with Phone V2 modules.
  - No other type of analog phone barrier box should be used.
- Where more than 3 barrier boxes are required in a building, they must be rack mounted using a [Barrier Box rack mounting kit](#)<sup>187</sup>.
- A maximum of 16 barrier boxes can be used with any Phone module.
- The Phone Barrier Box does not connect the ringing capacitor in Phone V1 modules.

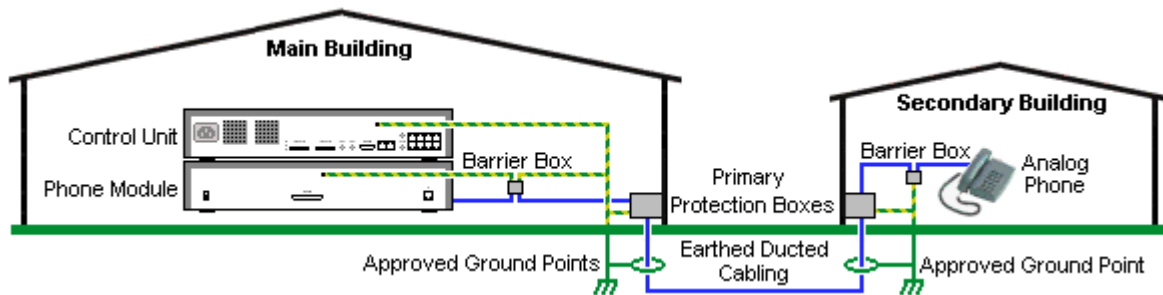

Main Building	Barrier Box	Secondary Building
<ul style="list-style-type: none"> <li><b>RJ11</b> Connect to PHONE (POT) port on the Phone module using cable supplied with the barrier box.</li> <li><b>RJ45</b> Connect to the secondary building barrier box via primary protection in both buildings.</li> </ul>		<ul style="list-style-type: none"> <li><b>RJ11</b> Connect to analog phone. Cable not supplied.</li> <li><b>RJ45</b> From main building via primary protection in both buildings.</li> </ul>
<ul style="list-style-type: none"> <li><b>Center Screw</b> Connect to main building protective ground (or ground terminal of Barrier Box Rack Mounting Kit). Use 18AWG (minimum) wire with a green and yellow sleeve.</li> <li><b>Right-Hand Screw</b> Connect to ground point on Phone module using ground cable supplied with barrier box.</li> </ul>		<ul style="list-style-type: none"> <li><b>Center Screw</b> Connect to main building protective ground. Use 18AWG (minimum) wire with a green and yellow sleeve.</li> <li><b>Right-Hand Screw</b> Not used.</li> </ul>

- The following wires must be kept apart, that is not routed in the same bundle:
  - Earth leads from the barrier box to the Phone modules.
  - Internal wires, for example extension leads going directly to the Phone modules.
  - Wires from external telephone going directly to the barrier boxes.

IP Office Barrier Boxes	SAP Code
<p><b>Phone Barrier Box (81V)</b> Use with Phone V1 module. Includes an RJ45 to RJ11 cable and a functional earth lead.</p>	700293897
<p><b>Phone Barrier Box V2 (101V)</b> Use with Phone V2 module. Includes an RJ45 to RJ11 cable and a functional earth lead.</p>	700385495
<b>Barrier Box Rack Mounting Kit</b>	700293905

### 11.14.3 Rack Mounting Barrier Boxes

Where more than 3 Phone Barrier Boxes are used they must be rack mounted. The Barrier Box Rack Mounting Kit (SAP Code 700293905) supports up to 8 Phone Barrier Boxes.

1. Unscrew the two screws arranged diagonally at the front of each barrier box and use these same screws to reattach the barrier box to the rack mounting strip.
2. Each barrier box is supplied with a solid green ground wire connected to its functional ground screw. Remove and discard this wire. Connect a green/yellow ground wire to the protective earth screw in the center of the Point on the back of the Barrier Box.

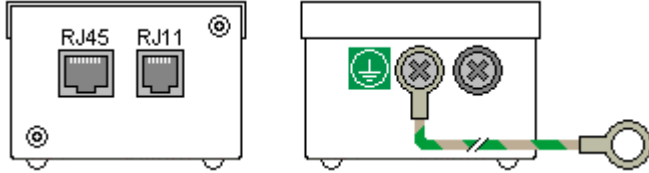

3. The rack mounting strip has threaded M4 earthing pillars. Connect the other end of the barrier box ground wire, using M4 washers and nuts, to the earthing pillar on that side of the rack mounting strip.

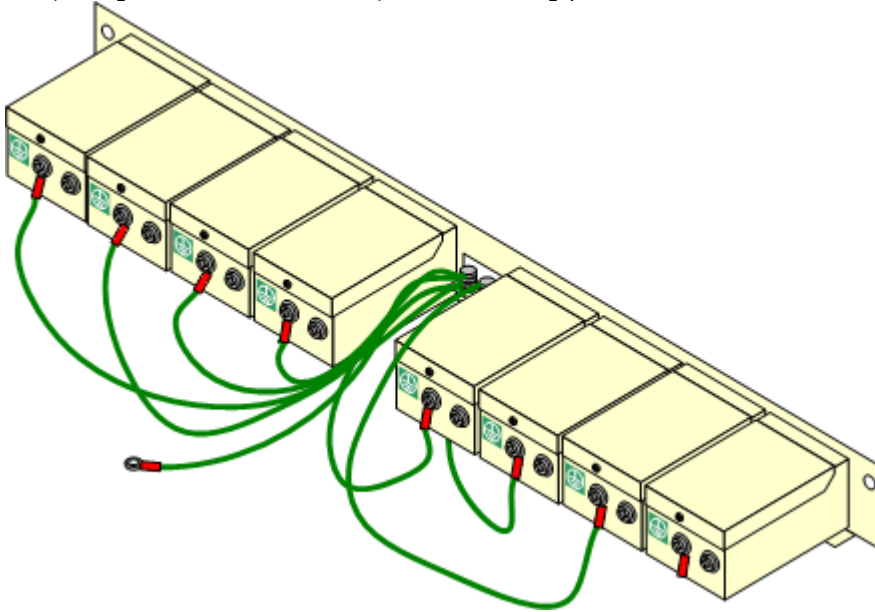

4. Using 14AWG wire with green and yellow sleeve, connect one of the earthing pillars to the buildings protective earth.
5. Using 14AWG wire with green and yellow sleeve, connect the other earthing pillar to the Phone module.
6. Ensure that the following wires are not routed together in the same bundle:
  - Earth lead from the barrier box to the Phone module.
  - Internal wires, e.g. wires going directly to the Phone module.
  - Wires from external telephone going directly to the barrier boxes.

## 11.15 Using the External Output Port

All the IP Office control units are equipped with a EXT O/P port. The port is marked as EXT O/P and is located on the back of the control unit adjacent to the power supply input socket.

The port can be used to control up to two external devices such as door entry relay switches. The usual application for these switches is to activate relays on door entry systems. However, as long as the criteria for maximum current, voltage and if necessary protection are met, the switches can be used for other applications.

The switches can be switched closed, open or pulsed (closed for 5 seconds and then open). This can be done in a number of ways:

- Using IP Office short codes.
- Through the **Door Release** option in IP Office SoftConsole.
- Via the **Open Door** action in Voicemail Pro.

### Default Short Codes

The following are the default short codes in the IP Office configuration for external output switch operation. They use the short code features Relay On (closed), Relay Off (open) and Relay Pulse.

State	Switch 1	Switch 2
Closed	*39	*42
Open	*40	*43
Pulse	*41	*44

### 11.15.1 Port Connection

These ports are found on the rear of all IP Office control units. They are used for connection to external switching relays. The port uses a standard 3.5mm stereo jack plug for connection.

The IP Office is able to open (high resistance), close (low resistance) or pulse (close for 5 seconds and then open) two switches within the port. Either switch can be operated separately. These switches are intended for activation of external relays in systems such as door opening systems.

- **CAUTION:**  
In installations where this port is connected to a device external to the building, connection must be via a MDS2 Surge Protector and a protective ground connection must be provided on the IP Office control unit. When using the MDS2 on the Ext O/P port, use only the Line 1 and Equipment 1 jacks, do not use the Line 2 or Equipment 2 jacks.

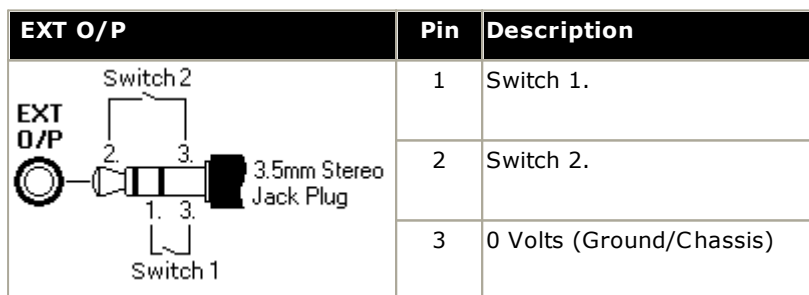

- Switching Capacity: 0.7A.
- Maximum Voltage: 55V d.c.
- On state resistance: 0.7 ohms.
- Short circuit current: 1A.
- Reverse circuit current capacity: 1.4A.
- Ensure that pins 1 and 2 are always at a positive voltage with respect to pin 3.

3.5mm stereo audio jack plugs are frequently sold as pre-wired sealed modules. It may be necessary to use a multi-meter to determine the wiring connections from an available plug. Typically 3 (common to both relays) is the cable screen.

## 11.16 SNMP

SNMP (Simple Network Management Protocol) is a standard network protocol that allows the monitoring and management of data devices across a network. An SNMP agent can be built into network devices such as routers and hubs. An SNMP manager application, for example CastleRock or HP OpenView, can then communicate with those devices.

IP Office 2.0 and above supports SNMP communication. This communication can be:

- **Polling:**

Some SNMP applications (called "managers") send out polling messages to the network. They then record the responds of any SNMP enabled devices (called "agents"). This allows the application to create a network map and to raise an alarm when devices previously present do not respond.

- Most SNMP manager applications can also do simple IP address polling to locate non-SNMP enabled devices. However this method of polling does not identify the device type or other information.
- SNMP polling including details about the responding device. For example an IP Office control unit's response includes the control unit type, level of software, routing table information, up time, etc.

- **Traps:**

When certain events occur, a devices SNMP agent can send details of the event to the SNMP manager. This is called an SNMP 'trap'. These appear in the event log of the SNMP manager. Most SNMP managers can be configured to give additional alerts in response to particular traps.

- **Management:**

Some SNMP agents support device management and configuration changes through the SNMP manager interface. This is not supported by IP Office.

IP Office SNMP operation has been tested against Castle Rock SNMPc-EE 5.1.6c and HP OpenView Network Node Manager 6.41.

### What Information is Available Via SNMP

As described above, SNMP information can either be polled by the SNMP application or received as the result of the IP Office sending SNMP trap information.

While the **.mib** files should not be edited, they can be read using a text editor and contain descriptions of all the various information objects that can be polled or sent and the information tha each object will include. For a list of the **.mib** files, see [Installing the IP Office MIB Files](#)<sup>190</sup>. The **NOTIFICATION-TYPE** objects are those used for [SNMP traps](#)<sup>192</sup>, the other types of objects are those that can be [polled](#)<sup>192</sup>.

---

## 11.16.1 Installing the IP Office MIB Files

To allow full communication between an SNMP agent and an SNMP manager, the SNMP manager must load MIB files (Management Information Base) specific to the SNMP agent device and the features it supports. These MIB files contain details of the information the agent can provide and the traps that it can send. Full details of the structure of the IP Office MIB files, MIB groups within those files and event traps can be found in the "IP Office Installation Manual".

The MIB files for IP Office operation are included on the IP Office DVD in the folder **\AdminCD\snmp\_mibs**. The actual files required and the method of loading depend on the SNMP manager application being used. The details below cover the two SNMP manager applications tested.

### HP Open View Network Node Manager

1. Copy the following MIB files to the applications MIBs folder.

	MIB File	Source
a.	rfc2737-entity-mib.mib	snmp_mibs\standard folder on OpenView Install CD.
b.	avayagen-mib.mib	\AdminCD\snmp_mibs\IPOffice folder on IP Office Admin DVD.
c.	ipo-prod-mib.mib	\AdminCD\snmp_mibs\IPOffice folder on IP Office Admin DVD.
d.	ipo-mib.mib	\AdminCD\snmp_mibs\IPOffice folder on IP Office Admin DVD.
e.	inet-address-mib.mib	\AdminCD\snmp_mibs\Standard folder on IP Office Admin DVD.
f.	rfc2213-integrated-services-mib.mib	\AdminCD\snmp_mibs\standard folder on OpenView Install CD.
g.	diffserv-dscp-tc.mib	\AdminCD\snmp_mibs\Standard folder on IP Office Admin DVD.
h.	diffserv-mib-hpov.mib	\AdminCD\snmp_mibs\Standard folder on IP Office Admin DVD.
i.	ipo-phones-mib.mib	\AdminCD\snmp_mibs\IPOffice folder on IP Office Admin DVD.

2. Start the OpenView Network Node Manager console.
3. Select Options and then Load/Unload MIBs: SNMP.
4. Select Load and select all the MIB files listed above.
5. Select Compile.

**CastleRock SNMPc 5.1.6c and earlier**

1. Copy the following MIB files to the applications MIBs folder, normally C:\Program Files\SNMPc Network Manager\mibfiles.

	MIB file	Source
a.	ENTITY-MIB	\AdminCD\snmp_mibs\Standard on IP Office Admin DVD.
b.	AVAYAGEN-MIB.mib	\AdminCD\snmp_mibs\IPOffice on IP Office Admin DVD.
c.	IPO-PROD-MIB.mib	\AdminCD\snmp_mibs\IPOffice on IP Office Admin DVD.
d.	IPO-MIB.mib	\AdminCD\snmp_mibs\IPOffice on IP Office Admin DVD.
e.	INET-ADDRESS-MIB.mib	\AdminCD\snmp_mibs\Standard on IP Office Admin DVD.
f.	INTEGRATED-SERVICES-MIB	\AdminCD\snmp_mibs\Standard on IP Office Admin DVD.
g.	DIFFSERV-DSCP-TC.mib	\AdminCD\snmp_mibs\Standard on IP Office Admin DVD.
h.	DIFFSERV-MIB.mib	\AdminCD\snmp_mibs\Standard on IP Office Admin DVD.
i.	IPO-PHONES-MIB.mib	\AdminCD\snmp_mibs\IPOffice on IP Office Admin DVD.

2. In SNMPc select Config | MIB Database.
3. Select Add and select the MIB files listed above in the order listed.

**CastleRock SNMPc V5.0.1**

The MIB installation instructions provided above are correct for CastleRock SNMPc V5.0.8 and later. For V5.0.1 of CastleRock SNMPc the following must be carried out:

1. Copy all of the IP Office MIBs and standard MIBs from the IP Office Administrator Applications DVD to the SNMPc mibfiles directory.
2. In the SNMPc mibfiles directory open the files STANDARD.mib and SNMPv2-SMI.mib in Notepad.
3. In the SNMPv2-SMI.mib file find the definition of zeroDotZero and copy this to the clipboard.
4. In the STANDARD.MIB file find the SNMPv2-SMI section and paste in the definition of zeroDotZero from the clipboard before the end of this section (just before the END statement).
5. Save the modified STANDARD.MIB file.
6. Add the MIB file SNMP-FRAMEWORK-MIB.mib to the MIB database using the instructions provided in the IP Office installation guide.
7. Add all the MIB files listed in the instructions provided in the IP Office installation guide in the order given.
8. Compile the MIBs ready for use.

The reason for this is: The IPO-PHONES-MIB.mib relies upon the DIFFSERV-MIB.mib for the definition of the textual convention of IndexInteger. The DIFFSERV-MIB needs the definition of the textual convention zeroDotZero which is normally defined in SNMPv2-SMI.mib. However including SNMPv2-SMI.mib in the MIB file compilation list results in errors due to conflicts with what appear to be internal definitions within SNMPc and the SNMPv2-SMI section in its STANDARD.mib file. Therefore to resolve the issue the required definition of zeroDotZero must be placed in the SNMPv2-SMI section in SNMPc's STANDARD.mib file.

---

## 11.16.2 Enabling SNMP and Polling Support

In order for the IP Office control unit to be discovered and polled by an SNMP manager, its SNMP agent must be enabled and placed in the same read community as the SNMP manager.

1. In IP Office Manager, receive the control unit's configuration.
2. Double-click **System** from the Configuration Tree panel and select the SNMP tab.
3. Tick **SNMP Enabled**.
4. In **SNMP Port**, enter the UDP port number used by the IP Office SNMP agent to listen for and respond to SNMP traffic. The normal default is 161.
5. In **Community (Read-only)**, enter the community to which the device belongs for read access. This community name must match that used by the SNMP manager application when sending requests to the device. The community public is frequently used to establish communication and then changed (at both the SNMP agent and manager ends) for security.
6. Click **OK**.
7. Send the configuration back to the IP Office and select reboot.
8. Following the IP Office reboot, the SNMP manager should be able to discover the control unit.
9. The control unit's response will include details of the control unit type and the current level of core software.

## 11.16.3 Enabling SNMP Trap Sending

In IP Office Manager, receive the control unit's configuration.

1. Double-click **System** from the configuration tree panel and select the **System Events** tab.
2. Ensure that **SNMP Enabled** is ticked and set the other settings required for the SNMP Agent Configuration section.
3. Click the Alarms tab.
4. Click **Add...** and select **Trap** as the type of new alarm. You can add up to 2 SNMP traps, each with different destination and alarm settings.
  - **Server Address**  
Enter the IP address or fully-qualified domain name of the PC running the SNMP manager application.
  - **Port**  
Enter the Port on which the traps messages should be sent. This is the UDP port on which the IP Office sends SNMP trap messages. The default is 162.
  - **Community**  
Set the Community that will be used by the agent and the SNMP manager. The community public is frequently used to establish communication and then changed (at both the SNMP agent and manager ends) for security.
  - **Format**  
The default to use is IP Office. SMGR is only used for system being managed through Avaya SMGR.
  - **Minimum Severity Level**  
Set the alarm severity or higher for alarms that should be sent.
5. Select the **Events** which should be sent.
6. Click on **OK**.
7. Send the configuration back to the IP Office and select reboot.

## 11.17 Refreshing the System Files from Manager

This process will copy all system files not present on the System SD card and those files which have a different version to those already present on the card. This process can be used to refresh the card contents if it is suspected some files may be missing.

This process is not supported as a method of upgrading. It should only be used with the version of IP Office Manager that matches the software already being run by the system.

- **Admin Lite Not Supported**

Note that the IP Office Manager installed using the **AdminLite** installer is not the full version. It runs in English only and does not include the files needed for actions such as system upgrades, SD card recreation, etc. To fully support systems, ensure that you install the full IP Office Administration suite installer (approximately 1.52GB compared to the 230MB **AdminLite** installer).

### To upgrade a system using the embedded file manager

1. Using IP Office Manager, select **File | Advanced | Embedded File Management**.
2. Using the **Select IP Office** menu, select the IP Office system.
3. The file contents of the memory cards are displayed.
4. Select **File | Backup System Files**. The contents of the **/primary** folder on the System SD card will be copied to the **/backup** folder. This process takes approximately 6 minutes.
5. Select **File | Upload System Files**. The system files that IP Office Manager has will be uploaded to the **/primary** folder on the System SD card. This includes IP Office software files and Embedded Voicemail prompt files. It does not include phone firmware and bin files. Depending on the files that need to be updated, this process can take up to 40 minutes.

## 11.18 Reset Button

IP500 V2 control units have a **Reset** button. Pressing the button while the control unit is starting up will pause the start up until the button is released. The effect of pressing the button during normal operation will depend on how long the button is pressed and is indicated by the CPU LED.

Press (seconds)	CPU LED	Action	Summary
0 to 5.	Off	None	None.
5 to 10.	Orange	Reboot When Free	Reboot when free with new incoming/outgoing call barring. A reboot using the reset button is recorded in the Audit Trail.
10 to 30.	Flashing orange	Erase Configuration	Erase the configuration, alarm log and audit trail. Immediate reboot without waiting for active calls to end. See <a href="#">Erasing the configuration</a> <sup>167</sup> for full details.
30 to 40.	Red	Erase All.	Erase configuration, alarm log and core software. See <a href="#">Erasing the Operational Software</a> <sup>196</sup> for full details.
Over 40.	Flashing green	None	None.

## 11.19 AUX Button

IP500 V2 control units have an AUX button. This button can be used as follows.







- If pressed during a restart of the control unit, the control unit [skips booting](#)<sup>139</sup> from the */primary* folder on the System SD card.
- If pressed for more than 5 seconds when a system is running, the control unit shuts down for 10 minutes.

## 11.20 RS232 Port Maintenance

The RS232 port on the back of system control unit is not normally used when configuring an IP Office system. However, the port can be used for a number of maintenance processes.

-  **WARNING**  
Use of the RS232 port should only be performed if absolutely necessary and only if the actions cannot be completed using IP Office Manager or IP Office Web Manager. In all cases, you must make every effort to ensure that you have a backup copy of the system configuration.

### RS232 Port Maintenance Processes



1. [RS232 port cable connection and configuration](#)  <sup>268</sup>
2. [Defaulting the configuration using debug](#)  <sup>168</sup>
3. [Defaulting the configuration using the Boot Loader](#)  <sup>169</sup>
4. [Defaulting the security using the RS232 port](#)  <sup>172</sup>
5. [Defaulting the security using the Boot Loader](#)  <sup>173</sup>
6. [Erasing the core software using debug](#)  <sup>197</sup>
7. [Erasing the core software using the Boot Loader](#)  <sup>198</sup>

---

## 11.21 Erasing the Core Software

When the firmware loaded by the control unit is erased, the control unit begins making BOOTP requests for replacement firmware files. IP Office Manager can act as a BOOTP server and respond to the control units request with the appropriate file from those installed with IP Office Manager.

Unlike other control units, when the firmware loaded by an IP500 V2 control unit is erased, the IP500 V2 control unit will first look for replacement firmware on its SD cards before falling back to using a BOOTP request to IP Office Manager.

-  Do not perform any of the following processes unless absolutely necessary. The IP Office software can normally be [upgraded using IP Office Manager](#)<sup>177</sup>.
-  This process erases the operational software. Before attempting this process you must know the MAC and IP addresses of the system, plus have a backup copy of its configuration and the correct .bin file for the control unit type and level of software.
-  The presence of any firewall blocking TFTP and or BOOTP causes this process to fail.

The processes below should be performed from a PC with a fixed IP address, directly connected to the IP Office control unit and with the IP Office system disconnected from any network. During the process, the control unit's IP address may default to a value in the 192.168.42.1 to 192.168.42.10 range. If this occurs, it may be necessary to amend the BOOTP entry in IP Office Manager to match the address the system is using.

### Process Options

- [Erasing Core Software Using the Reset Button](#)<sup>196</sup>
- [Erasing Core Software Using Debug](#)<sup>197</sup>
- [Erasing Core Software Using the Boot Loader](#)<sup>198</sup>

### 11.21.1 Erasing Core Software Using the Reset Button

Read the note and the warnings regarding [erasing the core software](#)<sup>196</sup> before using this process. Also read and note the warnings regarding [defaulting the configuration](#)<sup>167</sup> before using this process.

#### To erase the core software and configuration using the Reset button

Use this process to reboot the system when free. Once invoked, the system bars any new incoming or outgoing calls until after the reboot.

1. Run IP Office Manager.
  - In the **BOOTP** entries, check that there is an entry that matches the MAC Address, IP Address and .bin file used by the system. An entry is normally automatically created when a configuration has been loaded from that IP Office. .
    - If an entry is not present, create a new entry manually. The first two details can be found in the Control Unit settings in the configuration file. Then close and restart IP Office Manager.
  - Under **File | Preferences** ensure that IP Office Manager is set to 255.255.255.255. Also check that **Enable BootP Server** is checked.
  - Select **View | TFTPLog**.
  - Check that the required .bin file is present in Manager's working directory.
2. On the rear of the control unit, press and hold the **Reset** button for between 30 to 40 seconds until the **CPU** led changes to red.
3. When the **CPU** LED changes to red, release the button.
4. The system erases its current software and sends out a BootP request on the network for new software.

## 11.21.2 Erasing Core Software Using Debug

Read the note and the warnings regarding [erasing the core software](#)<sup>196</sup> before using this process.

-  **WARNING**

Use of the RS232 port should only be performed if absolutely necessary and only if the actions cannot be completed using IP Office Manager or IP Office Web Manager. In all cases, you must make every effort to ensure that you have a backup copy of the system configuration.

### To erase the core software using Debug

1. Run IP Office Manager.
  - In the **BOOTP** entries, check that there is an entry that matches the MAC Address, IP Address and .bin file used by the system. An entry is normally automatically created when a configuration has been loaded from that IP Office. .
    - If an entry is not present, create a new entry manually. The first two details can be found in the Control Unit settings in the configuration file. Then close and restart IP Office Manager.
  - Under **File | Preferences** ensure that IP Office Manager is set to 255.255.255.255. Also check that **Enable BootP Server** is checked.
  - Select **View | TFTPLog**.
  - Check that the required .bin file is present in Manager's working directory.
2. Attach the serial cable between the PC and the RS232 DTE port on the IP Office control unit.
  - a. Start the terminal program on your PC. Ensure that it has been setup as listed in [RS232 DTE Port Settings](#)<sup>268</sup>. Within a HyperTerminal session, the current settings are summarized across the base of the screen.
  - b. Enter **AT** (note upper case). The control unit should respond **OK**.
  - c. Enter **AT-DEBUG**. The control unit should response with the time and date and then **Hello>** to show it is ready to accept commands.
3. To erase the current configuration in RAM memory enter **upgrade**.
4. The IP Office will erase its current software and then send out a BootP request on the network for new software. IP Office Manager will respond and start transferring the software using TFTP.

---

### 11.21.3 Erasing Core Software Using the Boot Loader

Read the note and warnings regarding [erasing the core software](#)<sup>196</sup> before using this process.

-  **WARNING**

Use of the RS232 port should only be performed if absolutely necessary and only if the actions cannot be completed using IP Office Manager or IP Office Web Manager. In all cases, you must make every effort to ensure that you have a backup copy of the system configuration.

#### To erase the core software using the Boot Loader

1. Run IP Office Manager.
  - In the **BOOTP** entries, check that there is an entry that matches the MAC Address, IP Address and .bin file used by the system. An entry is normally automatically created when a configuration has been loaded from that IP Office. .
    - If an entry is not present, create a new entry manually. The first two details can be found in the Control Unit settings in the configuration file. Then close and restart IP Office Manager.
  - Under **File | Preferences** ensure that IP Office Manager is set to 255.255.255.255. Also check that **Enable BootP Server** is checked.
  - Select **View | TFTPLog**.
  - Check that the required .bin file is present in Manager's working directory.
2. Attach the serial cable between the PC and the RS232 DTE port on the IP Office control unit.
  - a. Start the terminal program on your PC. Ensure that it has been setup as listed in [RS232 DTE Port Settings](#)<sup>268</sup>. Within a HyperTerminal session, the current settings are summarized across the base of the screen.
  - b. Arrange the program windows so that the Terminal program and IP Office Manager TFTP Log are visible at the same time.
  - c. Switch off power to the IP Office control unit.
  - d. Power on the control unit and press the escape key every second until you get a Loader message. Below is an example.

```
P12 Loader 2.4
CPU Revision 0x0900
```
  - e. Enter **AT** (note upper case). The control unit should respond **OK**.
  - f. If an OK response is not received, check the settings of your terminal program and repeat the process above.
3. Enter **AT-X**. The control unit should respond **Multi-Sector Erase**.
4. The control unit will now request the .bin file it requires. For IP500 V2 control units this will be from files on the System SD card.
5. If the file transfers does not appear to be taking place, check that the IP address shown in the TFTP Log matches the BOOTP entry. Adjust the BOOTP entry if necessary.
6. When completed the system will reboot.

## 11.22 Enabling IP Office Web Manager

Access to IP Office Web Manager is via the system's IP address and then selecting the **IP Office Web Management** link. In order to use IP Office Web Manager, a number of criteria as listed below must be met. Most of these are applied automatic to a new system installed with IP Office Release 8.0 or higher. However, for systems being upgraded to IP Office Release 8.0 or higher, additional upgrade steps may be required.

### Enabling IP Office Web Manager

1. The IP Office Web Manager files must be present on the System SD card. This can be done in a number of way:
  - By selecting to include those files when prompted to do so while [recreating the IP Office SD card](#)<sup>141</sup> using IP Office Manager.
  - By selecting **Upload System Files** when upgrading the system using IP Office Manager.
2. The IP Office system security must allow IP Office Web Manager operation:
  - This is done automatically for any new system installed with IP Office Release 8.0 or higher software.
  - This is done automatically for any existing pre-IP Office Release 8.0 system during the upgrade if the system is set to use the pre-IP Office Release 8.0 default password.
  - For any system upgraded to IP Office Release 8.0 without first being set back to the default password, either:
    - Using IP Office Manager:
      1. If not already done, select **View | Advanced View**.
      2. Select **File | Advanced | Erase Security Settings (Default)**.
      3. From the **Select IP Office** dialog, select the required system and click **OK**.
      4. Enter the user name **Administrator** and the password for that account.
      5. IP Office Manager will confirm if the action was successful or not.
    - Default the [system security settings using an RS232 DTE cable](#)<sup>170</sup>.



# Chapter 12.

# System Components

---

## 12. System Components

This section covers the individual components that can comprise an IP Office installation.

- [IP500 V2 Control Unit](#)  203
- [IP500 V2 System SD Cards](#)  206
- [IP500 Base Cards](#)  207
- [IP500 Trunk Daughter Cards](#)  217
- [IP500 External Expansion Modules](#)  222
- [IP400 Expansion Modules](#)  230
- [Mounting Kits](#)  237
- [Phones](#)  239
- [Phone Button Modules](#)  240
- [Applications](#)  242
- [Operating System Support](#)  252
- [Physical Ports](#)  256
- [Licences](#)  269
- [Hardware/Software Compatibility](#)  276
- [PCS Levels](#)  285
- [TAA](#)  285

## 12.1 IP500 V2 Control Unit

The IP500 V2 control unit is a stackable unit with an optional 19" rack mounting kit and optional wall mounting kit for smaller configurations. The IP500 V2 control unit has 4 slots for the insertion of base cards.



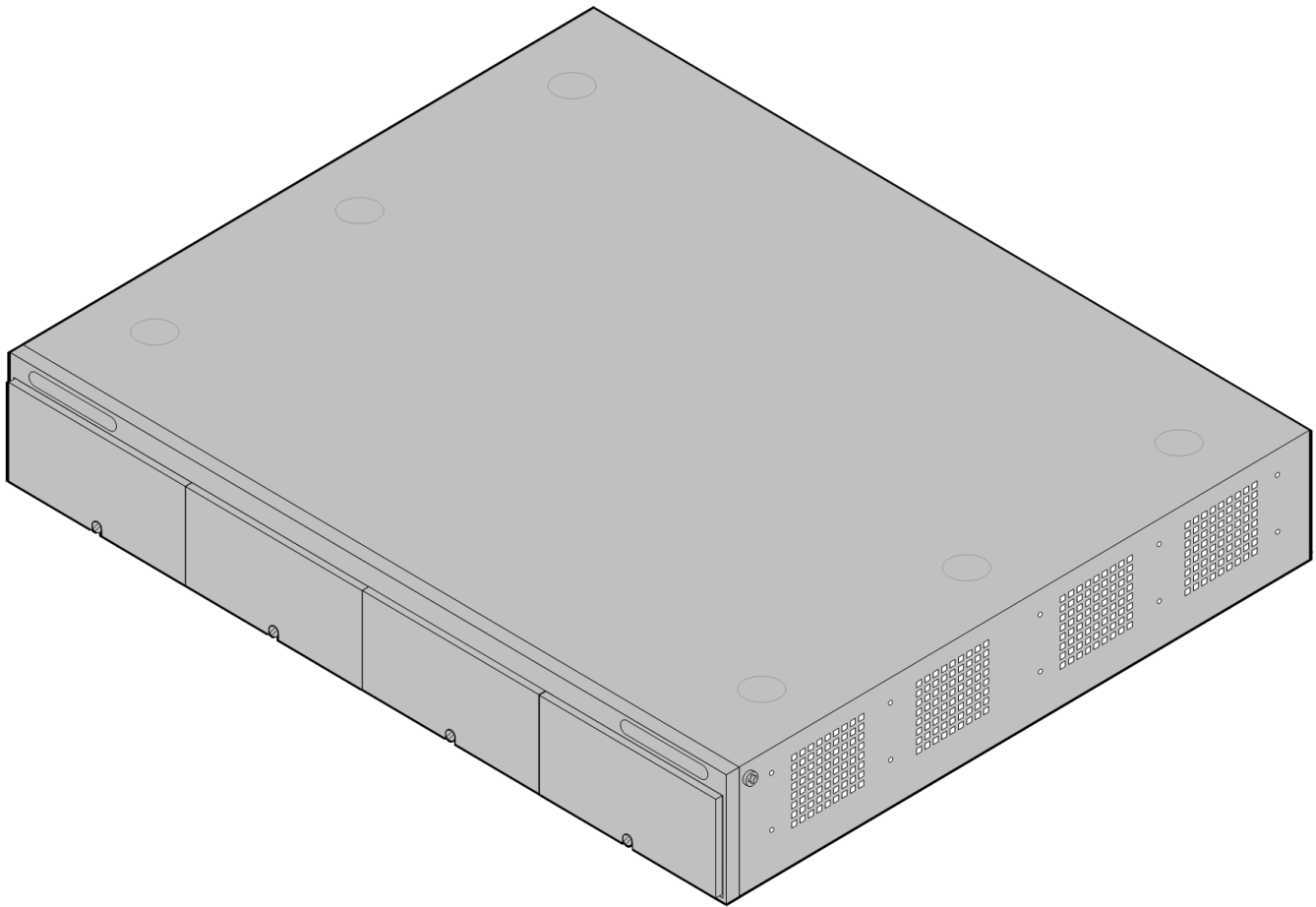





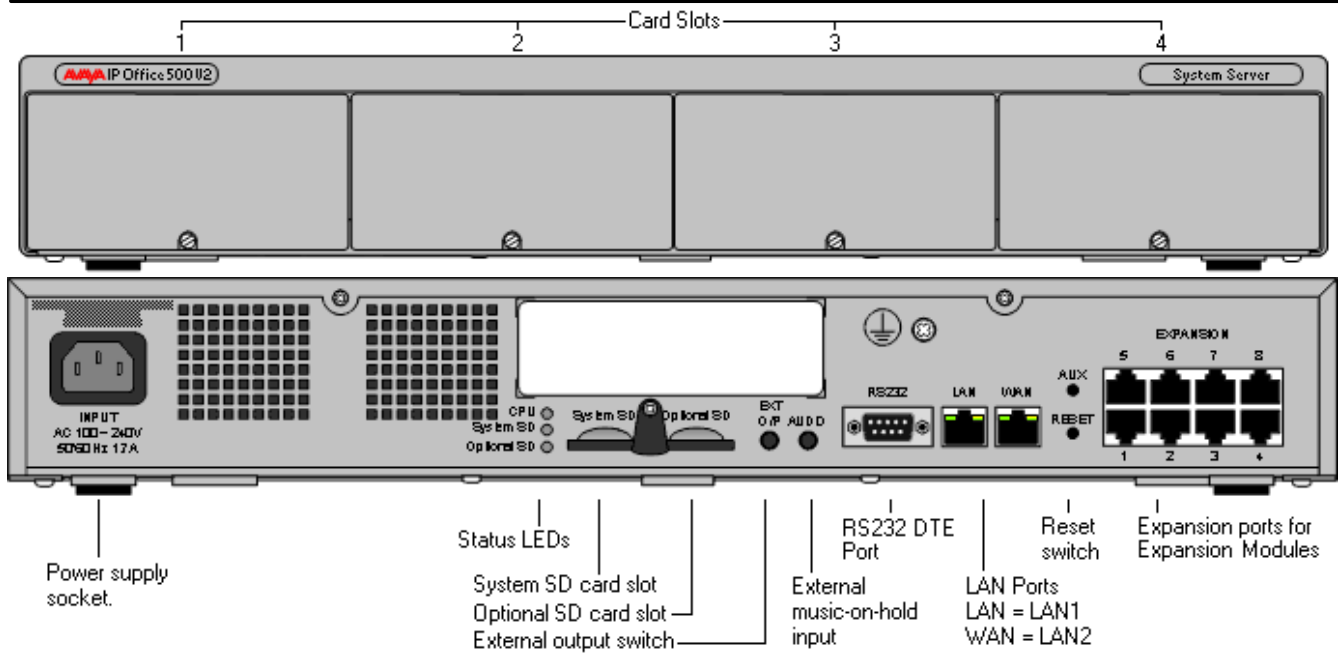







The slots are numbered 1 to 4 from left to right. They can be used in any order. However, if the capacity for a particular type of card is exceeded, the card in the rightmost slot is disabled. The unit must not be used with uncovered slots.



Feature	Capacity
<b>Maximum Extensions</b>	Up to 384 extensions (depending on the IP Office mode, see <a href="#">Overall Capacity</a> ) <sup>15</sup> .
<b>Conference Parties</b>	128 as standard but maximum 64 in any individual conference. Silence suppression is applied to conferences with more than 10 parties.
<b>Trunks Cards</b>	4 x IP500 trunk daughter cards, see <a href="#">IP500 Base Cards</a> <sup>207</sup> . Some base cards can also be fitted with trunk cards, see <a href="#">IP500 Trunk Daughter Cards</a> <sup>217</sup> .
<b>VCM Channels</b>	Up to 148 voice compression channels using a mix of IP500 VCM and IP500 Combination cards.
<b>Voicemail Channels</b>	Maximum 40 usable for Voicemail Pro/TAPI WAV connection sessions subject to available licenses. For Embedded Voicemail, up to 6 (2 by default, additional channels require licenses).
<b>Locales</b>	Supported in all <a href="#">IP Office locales</a> <sup>17</sup> .
<b>Minimum Software Level</b>	Bin file = ip500v2.bin. <ul style="list-style-type: none"> <li>IP500 V2: R6.0 and higher.</li> <li>IP500 V2A: R11.0.4.8 and higher.</li> </ul>
<b>Power Supply</b>	Internal power supply unit.
<b>Mounting</b>	Free-standing, rack mounted (requires a mounting kit) or wall mounted (requires a mounting kit).
<b>Dimensions</b>	Width: 445mm/17.5". Depth: 365mm/14.4". Height: 73mm/2.9"/2U. Clearance: 90mm minimum all sides, 220mm at front.
<b>Memory</b>	Maximum configuration file size: 2048KB.

Name	Description	Country	SAP Code	
IP500 V2 Control Unit	IPO IP500 V2 CNTRL Unit	IP Office 500 V2 Control Unit	700476005	
	IPO IP500 V2 CNTRL Unit TAA	" <a href="#">Trade Agreements Act</a> <sup>285</sup> compliant variant.	700501510	
IP500 V2A Control Unit	IPO IP500 V2A CNTRL UNIT	IP Office 500 V2A Control Unit	700514867	
	IPO IP500 V2A CNTRL UNIT TAA	" <a href="#">Trade Agreements Act</a> <sup>285</sup> compliant variant.	700514869	
Avaya SD Memory Card	IPO IP500 V2 SYS SD CARD AL	IP500 V2 A-Law SD Card	700479702	
	IPO IP500 V2 SYS SD CARD MUL	IP500 V2 U-Law SD Card	700479710	
IEC60320 C13 Earthed Power Cord 	IPO - PWR LEAD (EARTHED) EU CEE7/7	CEE7/7	Europe	700289762
	IPO - PWR LEAD (EARTHED) UK	BS1363	United Kingdom	700289747
	IPO - PWR LEAD (EARTHED) US	NEMA5-15P	America	700289770
Mounting Kits	IPO IP500 WALL MNTG KIT V3	IPO IP500 WALL MNTG KIT V3	700503160	
Miscellaneous	IP500 Blanking Plate Kit	IP500 Blanking Plate Kit	700429194	



Ports	Description
<b>AUDIO</b>  259	3.5mm Stereo jack socket. Used for external music on hold source input.
<b>AUX</b>  139	<ul style="list-style-type: none"> <li>If pressed during a restart of the control unit, the control unit <a href="#">skips booting</a>  from the <b>/primary</b> folder on the System SD card.</li> <li>If pressed for more than 5 seconds when a system is running, the control unit shuts down for 10 minutes.</li> </ul>
<b>CPU</b>	Indicates the status of the control unit. <ul style="list-style-type: none"> <li><b>Alternate red/green</b> = Starting up.</li> <li><b>Green on</b> = Okay.</li> <li><b>Red on</b> = No software.</li> <li><b>Flashing Red</b> = Error/Shutdown.</li> </ul>
<b>EXPANSION</b>  263	RJ45 socket. Used for direct connection to external expansion modules using the Expansion Interconnect cable supplied with the expansion module.
<b>EXT O/P</b>  188	3.5mm Stereo jack socket. Used for switching external relay systems such as door entry controls. The port contains two independent switches controlled by the IP Office.
<b>INPUT</b>  31	AC power input port.
<b>LAN</b>  264	RJ45 socket. The port is a full-duplex 10/100Mbps auto-sensing, MDI crossover port. With the WAN port forms a managed layer 3 Ethernet switch.
<b>Optional SD</b>  138	Used for the Optional SD card. The LED is used in the same way as for the System SD (see below).
<b>RESET</b>  194	This switch is used to restart the IP Office, optionally erasing the configuration and or the core software in the process. See <a href="#">Reset Button</a>  .
<b>RS232</b>  268	9-Way D-Type socket. Used for system maintenance. see <a href="#">RS232 Port Maintenance</a>  .
<b>System SD</b>  138	Used for the System SD card,. The LED is used as follows. <ul style="list-style-type: none"> <li><b>Off</b> = Card shutdown.</li> <li><b>Green on</b> = Card present.</li> <li><b>Green flashing</b> = Card in use.</li> <li><b>Orange steady</b> = Reset imminent.</li> <li><b>Red flashing</b> = Card initializing or shutting down.</li> <li><b>Red fast flashing</b> = card full</li> <li><b>Red steady</b> = Card failure/wrong type.</li> </ul>
<b>WAN</b>  264	RJ45 socket. The port is a full-duplex 10/100Mbps auto-sensing, MDI crossover port. With the WAN port forms a managed layer 3 Ethernet switch. This port is not supported on systems running in IP Office Basic Edition - PARTNER Mode, IP Office Basic Edition - Norstar Mode or IP Office Basic Editions.
	Used for connection of a <a href="#">functional or protective ground</a>  . Use of a ground for all systems is recommended and for some locales may be a regulatory requirement.

## 12.2 IP500 V2 System SD Cards

This type of card is used with IP500 V2 control units and is a mandatory item. The card is used for system licensing and also for Embedded Voicemail if required. It also holds the firmware files loaded by the system and telephones when the system is installed.

The control unit must be fitted with one of these feature keys even if no licenses are being used.



- The card's ID number is printed on the card's label after **PLDS ID**, **FK SN** or **FK** depending on the age of the card. On newer cards is a 12-digit number. Older cards may have a 10-digit number. For PLDS licensing, use the 12-digit number. On older cards, for licensing, prefix the 10-digit number with **11**.
- By default the card can be used for 2 ports of Embedded Voicemail. Additional ports up to a maximum of 6 can be enabled by the addition of [licenses](#)<sup>289</sup>. The voicemail mailbox message and prompt capacity supports 2 simultaneous connections and 15 hours of storage. This can be expanded up to 6 channels by the addition of licenses, each of which enables an additional two channels and an additional 5 hours of storage.
- **WARNING**  
These cards should only be formatted using IP Office Manager or System Status Application. The cards should only be removed from a system after either a [card shut down](#)<sup>151</sup> or a [system shut down](#)<sup>161</sup>.

Feature Key Dongle	SAP Code
IPO IP500 V2 SYS SD CARD A-LAW	700479702
IPO IP500 V2 SYS SD CARD MU-LAW	700479710

- **IP Office U-Law SD Card**  
A system fitted with this type of card defaults to U-Law telephony and IP Office Basic Edition **Key System** operation. Intended for North American locales.
- **IP Office A-Law SD Card**  
A system fitted with this type of card defaults to A-Law telephony and IP Office Basic Edition **PBX System** operation. Intended for locales outside North America.

### Embedded Voicemail

The System SD card can be used to provide Embedded Voicemail for the system.

By default the card can be used for 2 ports of Embedded Voicemail. Additional ports up to a maximum of 6 can be enabled by the addition of [licenses](#)<sup>289</sup>. The voicemail mailbox message and prompt capacity supports 2 simultaneous connections and 15 hours of storage. This can be expanded up to 6 channels by the addition of licenses, each of which enables an additional two channels and an additional 5 hours of storage.

For full details of Embedded Voicemail setup and configuration, refer to the ["Embedded Voicemail Installation"](#) manual. The cards are preloaded with the following languages:

- **Arabic, Cantonese, Danish, Dutch, English (UK), English (US), Finnish, French, French (Canada), German, Hebrew, Italian, Japanese, Korean, Mandarin, Norwegian, Polish, Portuguese, Portuguese (Brazil), Russian, Spanish, Spanish (Argentina), Spanish (Latin), Spanish (Mexico), Swedish, Turkish.**

### PCM Encoding

- **A-Law or Mu-Law**  
PCM (Pulse Code Modulation) is a method for encoding voice as data. In telephony, two methods PCM encoding are widely used, A-law and Mu-law (also called U-law). Typically Mu-law is used in North America and a few other locations while A-law by the rest of the world. As well as setting the correct PCM encoding for the region, the A-Law or Mu-Law setting of an IP Office system when it is first started affects a wide range of regional defaults relating to line settings and other values.
  - For IP500 V2 systems, the encoding default is set by the type of System SD card installed when the system is first started.

## 12.3 IP500 Base Cards

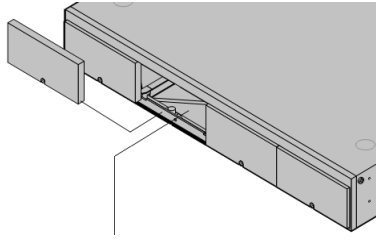

The IP500 V2 control unit has 4 slots for the insertion of IP500 base cards. The slots are numbered 1 to 4 from left to right. Normally they can be used in any order, however if the capacity for a particular type of card is exceeded, the card in the rightmost slot will be disabled.

Each base card includes an integral front panel with ports for cable connections. Typically the first 8 ports on the left are for connection of extension devices. The 4 ports on the left are used for connection of trunks if a [trunk daughter card](#)<sup>25</sup> is added to the base card.

### [IP500 Digital Station Base Card](#)<sup>213</sup>

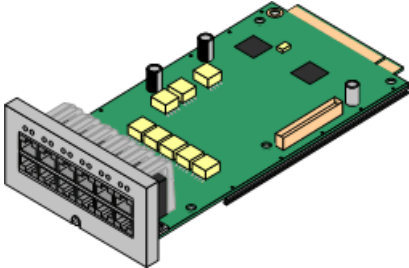

This card provides 8 DS (digital station) ports for the connection of Avaya digital phones (1400, 2400 and 9500 Series phones).

• **Maximum:**

- **DS8:** 3 per control unit. Not supported by IP500 V2A control units.
- **DS8A:** 4 per control unit.

### [IP500 Analog Phone Base Card](#)<sup>210</sup>

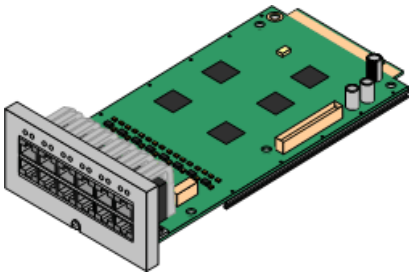

The card is available in two variants, supporting either 2 or 8 analog phone ports.

• **Maximum:** 4 per control unit.

- The analog phone ports do not include a ringing capacitor. Where this is a requirement, connection should be via a Master socket containing ringing capacitors.
- If fitted with an IP500 Analog Trunk daughter card, during power failure phone port 8 is connected to analog trunk port 12.

### [IP500 VCM Base Card](#)<sup>215</sup>

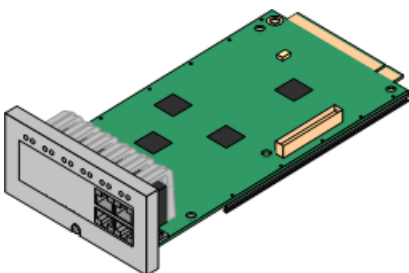

This card is available in variants supporting either 32 or 64 voice compression channels for use with VoIP calls.

• **Maximum:** 2 per control unit.

- The VCM V2 and V3 cards are functionally the same. However, VCM V3 cards are only supported for R11.1.3 and higher.

### [IP500 4-Port Expansion Base Card](#)<sup>209</sup>

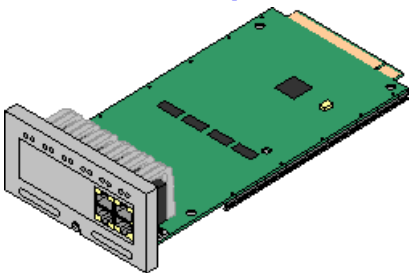

This card adds an additional 4 expansion ports for external expansion modules. The card is supplied with four 2m yellow interconnect cables.

• **Maximum:** 1 per control unit (Right-hand slot 4 only).

- This card does not accept a trunk daughter card.

• **Supported Expansion Modules:**

The 4-Port Expansion card supports the following external expansion modules:

- IP500 Analogue Trunk Module.
- IP500 BRI So Module.
- IP500 Digital Station Module.
- IP500 Digital Station Module A.
- IP500 Digital Station Module B.
- IP500 Phone Module.

### [IP500 BRI Combination Card](#)<sup>212</sup>

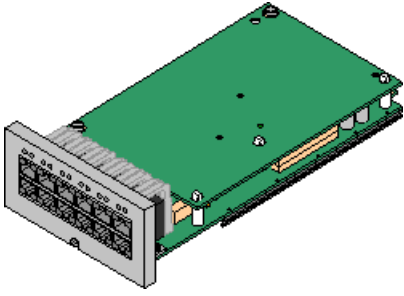

This card provides 6 digital station ports (1-6), 2 analog extension ports (7-8) and 2 BRI trunk ports (9-10, 4 channels). The card also includes 10 voice compression channels.

- **Maximum:** 2 per control unit.
- IP500 Combination cards are pre-fitted with a trunk daughter card which cannot be removed or changed for another type/capacity trunk daughter card.
- IP Office Basic Edition - Norstar Mode and IP Office Basic Edition systems are limited to a maximum of 12 BRI channels using BRI Combination and or BRI trunk daughter cards.

### [IP500 ATM Combination Card/IP500 ATM Combination Card V2](#)<sup>211</sup>

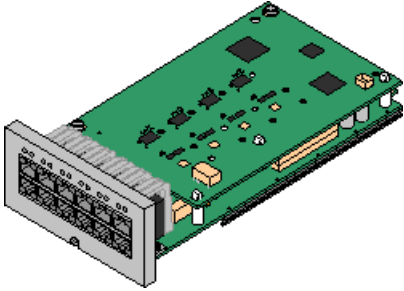

This card provides 6 digital station ports (1-6), 2 analog extension ports (7-8) and 4 analog trunk ports (9-12). The card also includes 10 voice compression channels.

- **Maximum:** 2 combination cards per control unit.
- IP500 Combination cards are pre-fitted with a trunk daughter card which cannot be removed or changed for another type/capacity trunk daughter card.
- The analog phone ports do not include a ringing capacitor. Where this is a requirement, connection should be via a Master socket containing ringing capacitors.
- During power failure phone port 8 is connected to analog trunk port 12.

### [Unified Communications Module](#)<sup>214</sup>

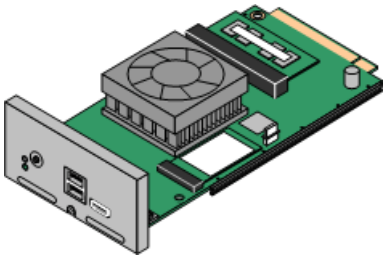

This card acts as an embedded Linux server for the Linux-based one-X Portal for IP Office and/or Voicemail Pro applications.

- **Maximum:** 1 per control unit.
- This card does not accept an IP500 trunk daughter card.

### 12.3.1 4-Port Expansion Card

This card is used to add 4 additional expansion ports to the control unit.

- Systems support up to 8 external expansion modules as standard. If fitted with an IP500 4-Port Expansion Base Card, up to 12 external expansion modules are supported.

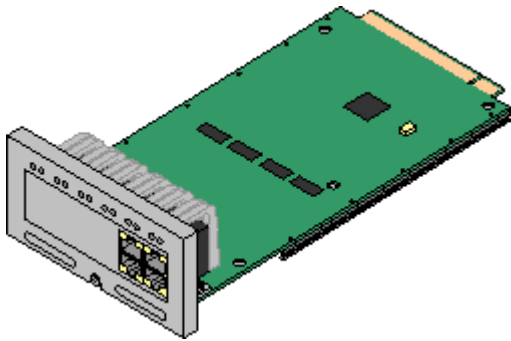

- **Supports**  
Provides 4 additional [expansion ports](#)<sup>283</sup> for connection of external expansion modules.
- **Supported Expansion Modules:**  
The 4-Port Expansion card supports the following external expansion modules:
  - IP500 Analogue Trunk Module.
  - IP500 BRI So Module.
  - IP500 Digital Station Module.
  - IP500 Digital Station Module A.
  - IP500 Digital Station Module B.
  - IP500 Phone Module.
- **Maximum per Control Unit:** 1 - Right-hand slot 4 only.
- **Trunk Card Support:** ×
- **IP Office Modes:** Not supported in IP Office Basic Edition modes.

- Each external expansion module is supplied with a blue 1 meter (3'3") expansion interconnect cable. This cable must be used when connecting to expansion ports on the rear of a control unit.
- When connecting to expansion ports on an IP500 4-Port Expansion card, a supplied yellow 2 meter (6'6") expansion interconnect cable can be used in place of the supplied blue cable. 4 Yellow cables are supplied with the IP500 4-Port Expansion card.

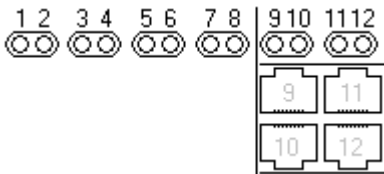

- LEDs 1 to 8 are used for the expansion ports on the rear of the control unit. LEDs 9 to 12 are used for the card's own expansion ports.

<b>Green</b>	<b>On</b>	Expansion module present.
<b>Red</b>	<b>Flashing</b>	Initializing.
<b>Red</b>	<b>On</b>	Error.
<b>Orange</b>	<b>Regular Flash</b>	Base card okay.

Name	Description	SAP Code
<b>IPO IP500 EXP CARD 4PT</b>	Includes 4 yellow 2 meter interconnect cables.	700472889
<b>IPO EXP CABLE RJ45/RJ45 2M YELLOW</b>	Only for use with the 4-Port Expansion card.	700472871

## 12.3.2 Analog Phone

This card is used to add analog phone ports to the control unit. It is available in two variants, providing either 2 or 8 analog extension ports.

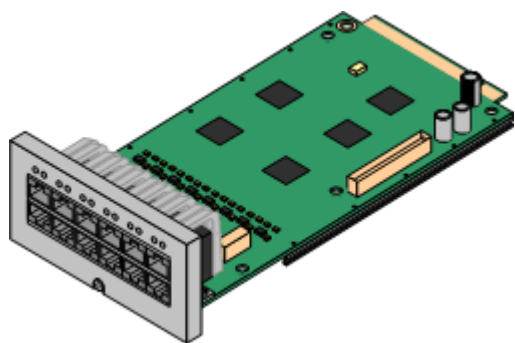

- **Supports**  
Provides either 8 or 2 [analog](#) phone ports depending on card variant.
- **Maximum per Control Unit:** 4.
- **Trunk Card Support:** ✓ 1.
- **IP Office Modes:** Supported in all modes.

Port Type	Ports	Features
<b>Analog Phone</b>	<b>1 to 8</b>	<ul style="list-style-type: none"> <li>• Supports ICLID modes DTMFA, DTMFC, DTMFD, FSK and UK20.</li> <li>• REN 2 (1 for external bell device).</li> <li>• Off-Hook current: 25mA</li> <li>• Ring Voltage: 40V.</li> <li>• Intended for connection to two-wire analog phones, the ports do not include a ringing capacitor. For connection to 4-wire analog phones, connection should be via a master socket with ringing capacitors.</li> <li>• If fitted with an analog trunk card, for the Phone 8, during power failure extension port 8 is connected to the analog trunk port 12.</li> </ul> <p><b>Port LEDs</b></p> <ul style="list-style-type: none"> <li>• No status LEDs are used for analog phone extensions.</li> <li>• LED1 is also used for base card status: <ul style="list-style-type: none"> <li>• <b>Red On</b> = Error/Not supported.</li> <li>• <b>Red Flash every 5 seconds</b> = Card okay.</li> <li>• <b>Red Slow Flash</b> = Initializing.</li> <li>• <b>Red Fast Flash</b> = System shutdown.</li> </ul> </li> </ul>
<b>Optional Trunk Card Ports</b>	<b>9 to 12</b>	<p>The card can be fitted with one trunk daughter card of any type. The trunk daughter card then uses ports 9 to 12 on the base card for its trunk connections.</p> <p><b>Port LEDs</b></p> <p>LED use depends on the type of daughter card installed on the base card:</p> <ul style="list-style-type: none"> <li>• LED 9 is also used for daughter card status. <ul style="list-style-type: none"> <li>• <b>Red On</b> = Error</li> <li>• <b>Red Flash every 5 seconds</b> = Card okay.</li> <li>• <b>Red Slow Flash</b> = Initializing.</li> <li>• <b>Red Fast Flash</b> = System shutdown.</li> </ul> </li> </ul> <p><b>Analog Card</b></p> <ul style="list-style-type: none"> <li>• <b>Green on</b> = Line connected to the port but idle.</li> <li>• <b>Green flashing</b> = Line in use.</li> </ul> <p><b>PRI Card</b></p> <ul style="list-style-type: none"> <li>• <b>Off</b> = No trunk present.</li> <li>• <b>Green on</b> = Trunk present.</li> <li>• <b>Green flashing</b> = Trunk in use.</li> <li>• <b>Red/Green Fast Flash</b> (port 9) or <b>Green Fast Flash</b> (port 10) = Alarm indication signal (AIS) from the trunk remote end.</li> <li>• <b>Red with Green Blink</b> (port 9) or <b>Green Blink</b> (port 10) = Port in loopback mode (set through IP Office System Monitor).</li> </ul> <p><b>BRI Card</b></p> <ul style="list-style-type: none"> <li>• <b>Off</b> = No trunk present.</li> <li>• <b>Green on</b> = Trunk present.</li> <li>• <b>Green flashing</b> = Trunk in use.</li> </ul>

Name	Description	SAP Code
<b>IPO 500 Extn Card Phone 2</b>	IP Office 500 Extension Card Phone 2	700431778
<b>IPO 500 Extn Card Phone 8</b>	IP Office 500 Extension Card Phone 8	700417231

### 12.3.3 ATM V2 Combination Card

These cards are used to add a combination of ports to an IP500 V2 control unit.

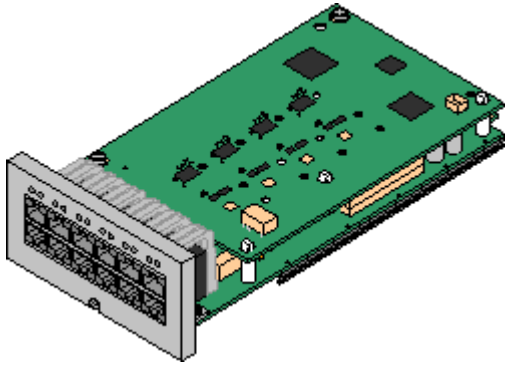

- **Supports**
  - 10 voice compression channels. Codec support is G.711, G.722, G.729a, and G.723 with 64ms echo cancellation.
  - 6 Digital Station ports for supported [Avaya DS digital telephones](#)<sup>39</sup> (except 3800 Series).
  - 2 Analog Extension ports.
  - 4 Analog Trunk ports:  
The analog trunk daughter card is equivalent to an [IP500 Analog Trunk Card V2](#)<sup>218</sup>.
  - During power failure, phone port 8 is connected to analog trunk port 12.
- **Maximum per Control Unit:** 2 combination cards of any type per control unit.
- **Trunk Card Support:** ✓ 1.
  - IP500 Combination cards are pre-fitted with a trunk daughter card which cannot be removed or changed for another type/capacity trunk daughter card.
- **IP Office Modes:** Supported in all modes.
- **Minimum Software Level:** 8.1 Feature Pack 1+.

Port Type	Ports	Features
Digit Station	1 to 6	<p>Provides <a href="#">DS</a><sup>202</sup> ports for supported <a href="#">Avaya DS digital telephones</a><sup>39</sup>.</p> <p><b>LEDs</b></p> <ul style="list-style-type: none"> <li>• <b>Green Flashing</b> = Phone detected.</li> <li>• <b>Green On</b> = Phone active.</li> <li>• LED1 is also used for base card status:               <ul style="list-style-type: none"> <li>• <b>Red On</b> = Error/Not supported.</li> <li>• <b>Red Flash every 5 seconds</b> = Card okay.</li> <li>• <b>Red Slow Flash</b> = Initializing.</li> <li>• <b>Red Fast Flash</b> = System shutdown.</li> </ul> </li> </ul>
Analog Phone	7 to 8	<ul style="list-style-type: none"> <li>• Supports ICLID modes DTMFA, DTMFC, DTMFD, FSK and UK20.</li> <li>• REN 2 (1 for external bell device).</li> <li>• Off-Hook current: 25mA</li> <li>• Ring Voltage: 40V.</li> <li>• Intended for connection to two-wire analog phones, the ports do not include a ringing capacitor. For connection to 4-wire analog phones, connection should be via a master socket with ringing capacitors.</li> <li>• During power failure, extension port 8 is connected to the analog trunk port 12.               <ul style="list-style-type: none"> <li>• No status LEDs are used for analog phone extensions.</li> </ul> </li> </ul>
Analog Trunk	9 to 12	<ul style="list-style-type: none"> <li>• DTMF, ICLID and busy tone detection.</li> <li>• Over-voltage/lightning protection (may still require <a href="#">additional protection equipment</a><sup>36</sup>).</li> <li>• DTMF and LD (loop disconnect) dialing.</li> <li>• Echo cancellation.</li> </ul> <p><b>LEDs</b></p> <ul style="list-style-type: none"> <li>• <b>Green on</b> = Line connected to the port but idle.</li> <li>• <b>Green flashing</b> = Line in use.</li> <li>• LED 9 is also used for daughter card status.               <ul style="list-style-type: none"> <li>• <b>Red On</b> = Error</li> <li>• <b>Red Flash every 5 seconds</b> = Card okay.</li> <li>• <b>Red Slow Flash</b> = Initializing.</li> <li>• <b>Red Fast Flash</b> = System shutdown.</li> </ul> </li> </ul>

Name	Description	SAP Code
IPO IP500 COMB CARD ATM4 V2	IPO IP500 COMBINATION CARD ATM4 V2	700504556

## 12.3.4 BRI Combination Card

This card is used to add a combination of ports to an IP500 V2 control unit.

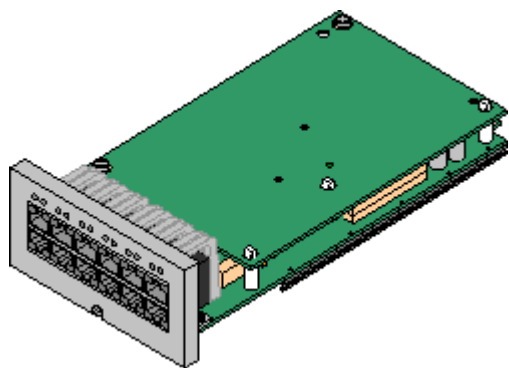

- **Supports**
  - 10 voice compression channels. Codec support is G.711, G.722, G.729a, and G.723 with 64ms echo cancellation.
  - 6 Digital Station ports for supported [Avaya DS digital telephones](#)<sup>39</sup> (except 3800 Series).
  - 2 Analog Extension ports.
  - 2 BRI Trunk ports (4 BRI channels).
- **Maximum per Control Unit:** 2 combination cards of any type.
  - IP Office Basic Edition - Norstar Mode and IP Office Basic Edition systems are limited to a maximum of 12 BRI channels using BRI Combination and or BRI trunk daughter cards.
- **Trunk Card Support:** ✓ 1.
  - IP500 Combination cards are pre-fitted with a trunk daughter card which cannot be removed or changed for another type/capacity trunk daughter card.
- **IP Office Modes:** Not supported in IP Office Basic Edition - PARTNER Mode mode.

Port Type	Ports	Features
Digit Station	1 to 6	Provides <a href="#">DS</a> <sup>262</sup> ports for supported <a href="#">Avaya DS digital telephones</a> <sup>39</sup> .  <b>LEDs</b> <ul style="list-style-type: none"> <li>• <b>Green Flashing</b> = Phone detected.</li> <li>• <b>Green On</b> = Phone active.</li> <li>• LED1 is also used for base card status:                             <ul style="list-style-type: none"> <li>• <b>Red On</b> = Error/Not supported.</li> <li>• <b>Red Flash every 5 seconds</b> = Card okay.</li> <li>• <b>Red Slow Flash</b> = Initializing.</li> <li>• <b>Red Fast Flash</b> = System shutdown.</li> </ul> </li> </ul>
Analog Phone	7 to 8	<ul style="list-style-type: none"> <li>• Supports ICLID modes DTMFA, DTMFC, DTMFD, FSK and UK20.</li> <li>• REN 2 (1 for external bell device).</li> <li>• Off-Hook current: 25mA</li> <li>• Ring Voltage: 40V.</li> <li>• Intended for connection to two-wire analog phones, the ports do not include a ringing capacitor. For connection to 4-wire analog phones, connection should be via a master socket with ringing capacitors.                             <ul style="list-style-type: none"> <li>• No status LEDs are used for analog phone extensions.</li> </ul> </li> </ul>
BRI Trunk	9 to 10	<ul style="list-style-type: none"> <li>• Each trunk port supports 2B+D channels.</li> <li>• ETSI or AustS013 basic rate protocol set through the IP Office configuration.</li> </ul> <b>LEDs</b> <ul style="list-style-type: none"> <li>• <b>Off</b> = No trunk present.</li> <li>• <b>Green on</b> = Trunk present.</li> <li>• <b>Green flashing</b> = Trunk in use.</li> <li>• LED 9 is also used for daughter card status.                             <ul style="list-style-type: none"> <li>• <b>Red On</b> = Error</li> <li>• <b>Red Flash every 5 seconds</b> = Card okay.</li> <li>• <b>Red Slow Flash</b> = Initializing.</li> <li>• <b>Red Fast Flash</b> = System shutdown.</li> </ul> </li> </ul>
Not Used	11 to 12	-

Name	Description	SAP Code
IPO IP500 COMB CARD BRI	IPO IP500 COMBINATION CARD BRI	700476021

### 12.3.5 Digital Station (DS8/DS8A)

This card is used to add digital station (DS) extension ports to an IP500 V2 control unit. It provides 8 RJ45 DS extension ports for use with supported [Avaya DS digital telephones](#)<sup>39</sup>. A further 4 RJ45 ports are provided for trunk connections when an IP500 trunk daughter card is fitted to this card.

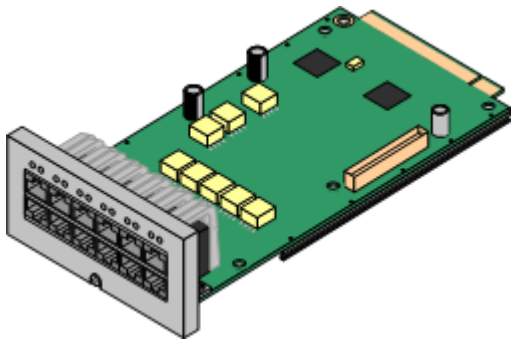

- **Supports**  
Provides 8 [DS](#)<sup>262</sup> ports for [Avaya DS digital telephones](#)<sup>39</sup> (except 3800 Series).
- **Maximum per Control Unit:**
  - **DS8:** 3 per control unit. Not supported by IP500 V2A control units.
  - **DS8A:** 4 per control unit.
- **Trunk Card Support:** ✓ 1.
- **IP Office Modes:** Supported in all modes.

Port Type	Ports	Features
Digit Station	1 to 8	<p>Provides <a href="#">DS</a><sup>262</sup> ports for supported <a href="#">Avaya DS digital telephones</a><sup>39</sup>.</p> <p><b>LEDs</b></p> <ul style="list-style-type: none"> <li>• <b>Green Flashing</b> = Phone detected.</li> <li>• <b>Green On</b> = Phone active.</li> <li>• LED1 is also used for base card status: <ul style="list-style-type: none"> <li>• <b>Red On</b> = Error/Not supported.</li> <li>• <b>Red Flash every 5 seconds</b> = Card okay.</li> <li>• <b>Red Slow Flash</b> = Initializing.</li> <li>• <b>Red Fast Flash</b> = System shutdown.</li> </ul> </li> </ul>
Optional Trunk Card Ports	9 to 12	<p>The card can be fitted with one trunk daughter card of any type. The trunk daughter card then uses ports 9 to 12 on the base card for its trunk connections.</p> <p><b>Port LEDs</b></p> <p>LED use depends on the type of daughter card installed on the base card:</p> <ul style="list-style-type: none"> <li>• LED 9 is also used for daughter card status. <ul style="list-style-type: none"> <li>• <b>Red On</b> = Error</li> <li>• <b>Red Flash every 5 seconds</b> = Card okay.</li> <li>• <b>Red Slow Flash</b> = Initializing.</li> <li>• <b>Red Fast Flash</b> = System shutdown.</li> </ul> </li> </ul> <p><b>Analog Card</b></p> <ul style="list-style-type: none"> <li>• <b>Green on</b> = Line connected to the port but idle.</li> <li>• <b>Green flashing</b> = Line in use.</li> </ul> <p><b>PRI Card</b></p> <ul style="list-style-type: none"> <li>• <b>Off</b> = No trunk present.</li> <li>• <b>Green on</b> = Trunk present.</li> <li>• <b>Green flashing</b> = Trunk in use.</li> <li>• <b>Red/Green Fast Flash</b> (port 9) or <b>Green Fast Flash</b> (port 10) = Alarm indication signal (AIS) from the trunk remote end.</li> <li>• <b>Red with Green Blink</b> (port 9) or <b>Green Blink</b> (port 10) = Port in loopback mode (set through IP Office System Monitor).</li> </ul> <p><b>BRI Card</b></p> <ul style="list-style-type: none"> <li>• <b>Off</b> = No trunk present.</li> <li>• <b>Green on</b> = Trunk present.</li> <li>• <b>Green flashing</b> = Trunk in use.</li> </ul>

Name	Description	SAP Code
IPO IP500 EXTN CARD DGTL STA 8A	IP Office 500 Extension Card Digital Station 8	700514857
IPO IP500 EXTN CARD DGTL STA 8A TAA	" <a href="#">Trade Agreements Act</a> <sup>265</sup> compliant variant.	700514868
IPO IP500 EXTN CARD DGTL STA 8	IP Office 500 Extension Card Digital Station 8	700417330
IPO IP500 EXTN CARD DGTL STA 8 TAA	" <a href="#">Trade Agreements Act</a> <sup>265</sup> compliant variant.	700501512

## 12.3.6 Unified Communications Module

This card is an embedded server that allows Linux-based IP Office applications (Voicemail Pro, one-X Portal for IP Office) to run within the IP Office control unit rather than requiring separate PCs. The Unified Communications Module v2 is supported by IP Office Release 9.1 and higher.

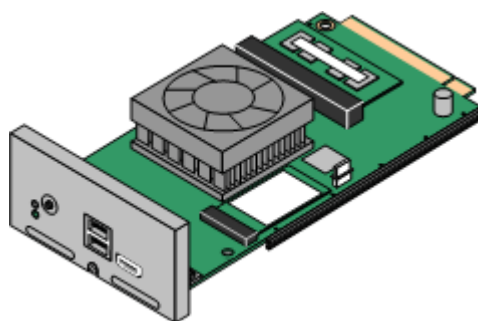

Unified Communications Module v2

- **UCM support in IP Office R12.0 and higher systems**

The Unified Communications Module (UCM) cannot support the 64-bit Linux used for IP Office R12.0 and higher. Therefore, you cannot upgrade a UCM to run R12.0.x software. However, Avaya supports UCM modules running R11.1.3.2 software in IP Office R12.0 and higher systems with the following caveats:

- If the existing Unified Communications Module is running pre-R11.1 software, you must upgrade it to R11.1.3.2 using the processes in the *"Upgrading Linux-based IP Office Systems to R11.1"* manual.
- The IP Office system will output a UCM version mismatch alarm each time the IP Office is restarted. You can ignore this alarm.
- There will be no future updates to the IP Office software components provided on the UCM modules.
- There will be no any future updates for the CentOS operating system and no security CVE patches for UCM modules.

- **Supports:**

Voicemail Pro and or one-X Portal for IP Office applications only.

- **IP Office Users:** Up to 200 users when running Voicemail Pro and one-X Portal for IP Office. More than 200 users when running just Voicemail Pro.
- **Simultaneous one-X Portal for IP Office Users:** 50.
- **Maximum voicemail ports:** Up to 20 ports when running Voicemail Pro and one-X Portal for IP Office. Up to 40 ports when running just Voicemail Pro.
- **Small Community Network:** Maximum 6 systems.

- **Licenses:**

For both card types, an **Essential Edition** license is required as a pre-requisite. The voicemail server on the card also requires the system to have a **Preferred Edition** license.

- On pre-IP Office R10.0 systems the Unified Communications Module v1 granted the host system the virtual Preferred Edition license it needed for Voicemail Pro. Existing IP Office systems being upgraded to IP Office R10.0 or higher must use the IP Office license migration process to retain the existing license.

- **Maximum per Control Unit:** 1 per control unit.

- **Trunk Card Support:** ×

- **IP Office Modes:** Not supported in IP Office Basic Edition modes.

- **! WARNING: Card Remains Hot After System Shutdown**

When removing an Unified Communications Module from a system, care should be taken not to touch the heat sink on the module. The heat sink remains hot for a long period after system shutdown.

Name	Description	SAP Code
IPO UC MODULE V2	IP Office Unified Communications Module v2	700507449

### 12.3.7 VCM V2/VCM V3

This type of card is used to add voice compression channels to the control unit. Those channels are used for VoIP calls including IP extensions and or IP trunks. IP500 V2 control units support up to 148 voice compression channels, using IP500 VCM cards and [IP500 Combination Cards](#)<sup>211</sup>.

The cards are available in 32 channel and 64 channel variants. All the card variants have 4 RJ45 ports which are used for trunk connections when an [IP500 trunk daughter card](#)<sup>217</sup> is fitted. V2 and V3 VCM cards are identical in supported features and functionality except for minimum supported IP Office version (see below).

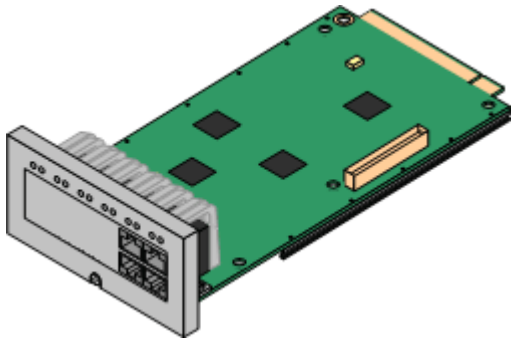

• **Supports**

Codecs G.711, G.722, G.729ab, and G.723 with 64ms echo cancellation. The maximum number of channels useable is affected by the codec used. The following table assumes all calls use the same codec. Note: G729b is not supported by Linux-based IP Office systems.

Codec	IP500 VCM 32 V2/V3	IP500 VCM 64 V2/V3
<b>G.711</b>	32	64
<b>G.729ab</b>	30	60
<b>G.723</b>	22	44
<b>G.722</b>	30	60

- **Maximum per Control Unit:** 2.
- **Trunk Card Support:** ✓ 1.
- **IP Office Modes:** Not supported in IP Office Basic Edition.
- **Minimum software level:**
  - **VCM V2 Cards:** Supported for IP Office R8.1 and higher.
  - **VCM V3 Cards:** Supported for IP Office R11.1.3 and higher.

Port Type	Ports	Features
<b>Not present</b>	<b>1 to 8</b>	<ul style="list-style-type: none"> <li>• LEDs 1 to 8 are unlabelled. They are used to indicate voice compression channel usage. Each LED represents 12.5% of available voice compression channel capacity.</li> <li>• LED1 is also used for base card status:                             <ul style="list-style-type: none"> <li>• <b>Red On</b> = Error/Not supported.</li> <li>• <b>Red Flash every 5 seconds</b> = Card okay.</li> <li>• <b>Red Slow Flash</b> = Initializing.</li> <li>• <b>Red Fast Flash</b> = System shutdown.</li> </ul> </li> </ul>
<b>Optional Trunk Card Ports</b>	<b>9 to 12</b>	<p>The card can be fitted with one trunk daughter card of any type. The trunk daughter card then uses ports 9 to 12 on the base card for its trunk connections.</p> <p>LED use depends on the type of daughter card installed on the base card:</p> <ul style="list-style-type: none"> <li>• LED 9 is also used for daughter card status.                             <ul style="list-style-type: none"> <li>• <b>Red On</b> = Error</li> <li>• <b>Red Flash every 5 seconds</b> = Card okay.</li> <li>• <b>Red Slow Flash</b> = Initializing.</li> <li>• <b>Red Fast Flash</b> = System shutdown.</li> </ul> </li> </ul> <p><b>Analog Card</b></p> <ul style="list-style-type: none"> <li>• <b>Green on</b> = Line connected to the port but idle.</li> <li>• <b>Green flashing</b> = Line in use.</li> </ul> <p><b>PRI Card</b></p> <ul style="list-style-type: none"> <li>• <b>Off</b> = No trunk present.</li> <li>• <b>Green on</b> = Trunk present.</li> <li>• <b>Green flashing</b> = Trunk in use.</li> <li>• <b>Red/Green Fast Flash</b> (port 9) or <b>Green Fast Flash</b> (port 10) = Alarm indication signal (AIS) from the trunk remote end.</li> <li>• <b>Red with Green Blink</b> (port 9) or <b>Green Blink</b> (port 10) = Port in loopback mode (set through IP Office System Monitor).</li> </ul> <p><b>BRI Card</b></p> <ul style="list-style-type: none"> <li>• <b>Off</b> = No trunk present.</li> <li>• <b>Green on</b> = Trunk present.</li> <li>• <b>Green flashing</b> = Trunk in use.</li> </ul>

	Name	Description	SAP Code
IP500 Voice Compression Modules V2	IPO IP500 MC VCM 32 V2	IP500 Media Card Voice Coding Module 32 V2	700504031
	IPO IP500 VCM 32 TAA V2	" <a href="#">Trade Agreements Act</a> <sup>285</sup> compliant variant.	700504033
	IPO IP500 MC VCM 64 V2	IP500 Media Card Voice Coding Module 64 V2	700504032
IP500 Voice Compression Modules V3	IPO IP500 VCM 32 V3 MEDIA CARD	IP500 Media Card Voice Coding Module 32 V2	700517168
	IPO IP500 VCM 32 V3 MEDIA CARD TAA	" <a href="#">Trade Agreements Act</a> <sup>285</sup> compliant variant.	700517170
	IPO IP500 VCM 64 V3 MEDIA CARD	IP500 Media Card Voice Coding Module 64 V2	700517169

## 12.4 IP500 Trunk Daughter Cards

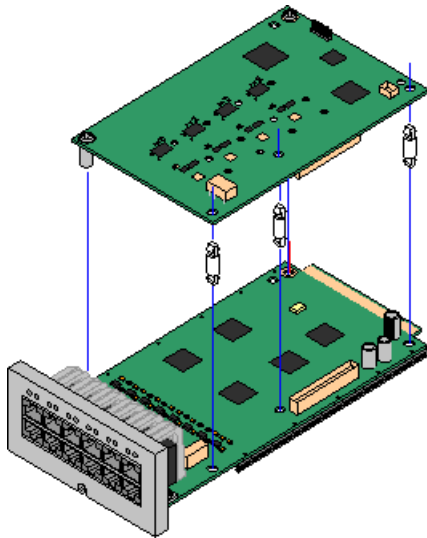

Many [IP500 base cards](#)<sup>23</sup> can be fitted with an IP500 trunk daughter cards to support the connection of trunks to the base card.

Each daughter card is supplied with the stand off pillars required for installation and a label to identify the daughter cards presence on the front of the base card after installation.

- IP500 Combination cards are pre-fitted with a trunk daughter card which cannot be removed or changed for another type of trunk daughter card.

### [IP500 Analog Trunk Card V2](#)<sup>218</sup>

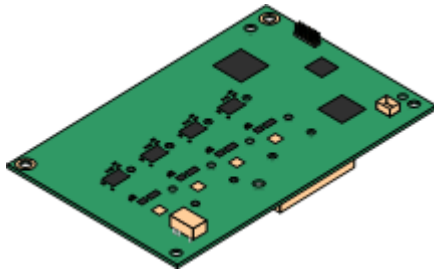

These cards allow the base card to support 4 analog loop-start trunks.

- **Maximum:** 4 per control unit.
  - The analog phone ports do not include a ringing capacitor. Where this is a requirement, connection should be via a Master socket containing ringing capacitors.
  - If fitted to a base card with analog phone ports, during power failure phone port 8 is connected to analog trunk port 12.

### [IP500 PRI-U Trunk Card](#)<sup>220</sup>

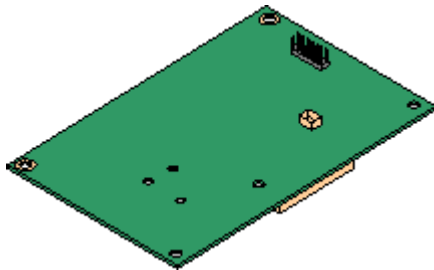

This type of card allows the base card to support PRI trunk connections. The cards are available in single and dual port variants. The card can be configured for E1 PRI, T1 robbed bit, T1 PRI or E1R2 PRI trunks.

- **Maximum:** 4 PRI port cards.
- The IP Office supports 8 unlicensed B-channels on each IP500 PRI-U port fitted. Additional B-channels, up to the capacity of ports installed and PRI mode selected require [IP500 Universal PRI \(Additional Channels\)](#)<sup>270</sup> licenses added to the configuration. These additional channels consume the licenses based on which additional channels are configured as in-service from port 9 of slot 1 upwards. D-channels are not affected by licensing.
- The PRI-U V2 cards are functionally the same as previous PRI cards, but only supported with IP Office R11.1 FP2 SP4 and higher.

### [IP500 BRI Trunk Card](#)<sup>219</sup>

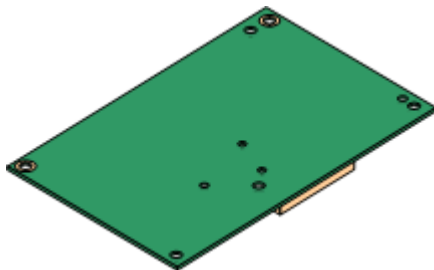

This card allows the base card to support up to 4 BRI trunk connections, each trunk providing 2B+D digital channels. The card is available in 2-port (4 channels) and 4-port (8 channels) variants.

- **Maximum:** 4 per control unit.
- **S-Bus Connection:** The card can be switched from To trunk mode to So mode. This mode requires additional terminating resistors and an ISDN crossover cable connection, see [BRI Port \(So\)](#)<sup>260</sup>.

## 12.4.1 Analog Trunk Card V2

These cards can be added to an IP500 base card to provide that card with support for 4 loop-start analog trunks. This card can be fitted to any non-combo IP500 base card except the IP500 4-Port Expansion card.

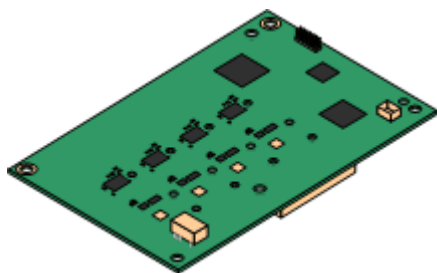

- **Ports/Channels**

4 Loop-start analog trunk ports. Connections via the host IP500 base card.

- DTMF, ICLID and busy tone detection.
- Over-voltage/lightning protection (may still require [additional protection equipment](#)<sup>36</sup>).
- DTMF and LD (loop disconnect) dialing.
- Echo cancellation.

- **Echo Cancellation**

Echo cancellation manually selectable to either **On** or **Off**. The default is **On**. The IP500 Analog Trunk Card V2 also supports echo reduction which is set to **On** by default.

- **Service Status/Line Status Indication**

Automatic detection of line status for idle lines. The card LEDs and System Status Application indicate that the individual line is connected and idle or is in use.

- **Impedance Matching**

This card supports automatic impedance matching at system startup and this mode is enabled by default. Manual or no impedance matching can be used if required. Impedance matching is supported in all locales.

- **Voice Activity Detection (VAD)**

When enabled, allows the support on analog trunks of functions that require call progress indication, for example the use of mobile twinning. This function does not enable support for mobile call control. The function is not enabled by default.

- **Power Failure Port**

During power failure, pins 4 and 5 of port 12 are connected to pins 7 and 8. In addition, when fitted to an IP500 Analog Phone 8 base card, extension port 8 is connected to the analog trunk port 12.

- **License:** No license required.

- **Maximum per Control Unit:** 4.

- **Minimum Software Level:** 8.1 Feature Pack 1+

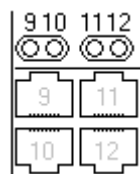

### Daughter Card Ports (9-12)

The LEDs for ports 9 to 12 of the IP500 base card are used as follows:

- **Green on** = Line connected to the port but idle.
- **Green flashing** = Line in use.
- LED 9 is also used for daughter card status.
  - **Red On** = Error
  - **Red Flash every 5 seconds** = Card okay.
  - **Red Slow Flash** = Initializing.
  - **Red Fast Flash** = System shutdown.

Name	Description	SAP Code
IPO IP500 Trunk Card Anlg 4 V2	IP Office 500 Trunk Card Analog 4 Universal V2	700503164

## 12.4.2 BRI Trunk Cards

This card can be added to an IP500 base card to provide that card with support for [BRI-To](#)<sup>261</sup> trunks. The card is available in 8 channel (4 physical trunks) or 4 channel (2 physical trunks) variants.

This card can be fitted to any non-combo IP500 base card except the IP500 4-Port Expansion card.

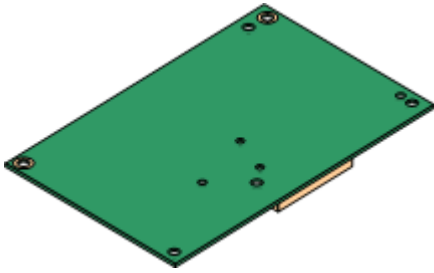

- **Ports/Channels**

2 or 4 BRI trunk ports. Connections via ports 9 to 12 of the host IP500 base card.

- Each trunk port supports 2B+D channels.
- ETSI or AusTS013 basic rate protocol set through the IP Office configuration.
- **License:** No license required.
- **Maximum per Control Unit:** 4.
- **Minimum Software Level:** 4.0+.
- **S-Bus Connection:** On IP Office 4.2+ systems, the card can be switched from [To](#)<sup>261</sup> trunk mode to [So](#)<sup>260</sup> mode. This mode requires additional terminating resistors and an ISDN crossover cable connection, see [BRI Port \(So\)](#)<sup>260</sup>.
- This card is approved for use in the following countries: Argentina, Australia, Brazil, China, European Union (EU), India, New Zealand, Russia, South Africa, and United Arab Emirates (UAE).

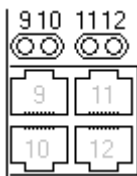

### Daughter Card Ports (9-12)

The LEDs for ports 9 to 12 of the IP500 base card are used as follows:

- **Off** = No trunk present.
- **Green on** = Trunk present.
- **Green flashing** = Trunk in use.
- LED 9 is also used for daughter card status.
  - **Red On** = Error
  - **Red Flash every 5 seconds** = Card okay.
  - **Red Slow Flash** = Initializing.
  - **Red Fast Flash** = System shutdown.

Name	Description	SAP Code
IPO 500 Trnk BRI 4 Uni	IP Office 500 Trunk Card Basic Rate 4 Universal	700417413
IPO IP500 TRNK BRI 4 UNI TAA	" <a href="#">Trade Agreements Act</a> <sup>265</sup> compliant variant.	700501515
IPO 500 Trnk BRI 8 Uni	IP Office 500 Trunk Card Basic Rate 8 Universal	700417421
IPO IP500 BRI SO CONVTR CBL	IP500 BRI So Converter Cable	700458649

## 12.4.3 PRI Trunk Cards

This type of card can be added to an IP500 base card to provide that card with support for PRI trunks. The card is available in single port or dual port variants.

This card can be fitted to any non-combo IP500 base card except the IP500 4-Port Expansion card.

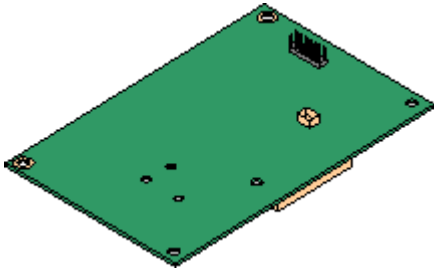

- **Ports/Channels:**
  - 1 or 2 [PRI trunk ports](#)<sup>267</sup>. Each port supports the following PRI line types. On dual port cards, both ports will be the same line type. The line type selection can be changed using IP Office Manager. The options available depend on the IP Office operation mode and locale.
    - E1 PRI (30B+D channels per port).
    - E1R2 PRI (30B channels per port).
    - T1 robbed bit (24B channels per port) or T1 PRI (23B+D channels per port).
  - The required mode can be selected within IP Office Manager by right-clicking on the line icon and selecting **Change Universal PRI Card Line Type** and then selecting the required line type.
  - Physical trunk connection is via ports 9 and 10 of the host IP500 base card.
  - Port 11 and 12 can be used as test points for connection of test and monitoring equipment for the adjacent port.
- **Licenses:**
  - The IP Office system supports 8 unlicensed B-channels on each IP500 PRI-U port fitted. Additional B-channels, up to the capacity of ports installed and PRI mode selected require IP500 Universal PRI (Additional Channels) licenses added to the configuration. These additional channels consume the licenses based on which additional channels are configured as in-service from port 9 of slot 1 upwards. D-channels are not affected by licensing.
- **Maximum per Control Unit:** 4 per control unit.
- **Minimum Software Level:**
  - **IP500 PRI-U Cards:** IP Office R4.1+.
  - **IP500 PRI-U V2 Cards:** IP Office R11.1.2.4+

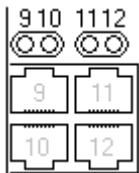

### Daughter Card Ports (9-12)

The LEDs for ports 9 to 12 of the IP500 base card are used as follows:

- **Off** = No trunk present.
- **Green on** = Trunk present.
- **Green flashing** = Trunk in use.
- **Red/Green Fast Flash** (port 9) or **Green Fast Flash** (port 10) = Alarm indication signal (AIS) from the trunk remote end.
- **Red with Green Blink** (port 9) or **Green Blink** (port 10) = Port in loopback mode (set through IP Office System Monitor).
- LED 9 is also used for daughter card status.
  - **Red On** = Error
  - **Red Flash every 5 seconds** = Card okay.
  - **Red Slow Flash** = Initializing.
  - **Red Fast Flash** = System shutdown.

Name	Description	SAP Code
IPO 500 TRNK PRI UNVRSL SNGL	IP Office 500 Trunk Card Primary Rate 1 Universal	700417439
IPO IP500 TRNK PRI UNVRSL SNGL TAA	" <a href="#">Trade Agreements Act</a> <sup>265</sup> compliant variant.	700501514
IPO 500 TRNK PRI UNVRSL DUAL	IP Office 500 Trunk Card Primary Rate 2 Universal	700417462
IPO IP500 TRNK PRI UNVRSL DUAL TAA	" <a href="#">Trade Agreements Act</a> <sup>265</sup> compliant variant.	700501517
IPO IP500 TRNK PRI V2 UNVRSL SNGL	IP Office 500 Trunk Card Primary Rate 1 Universal V2	700515485
IPO IP500 TRNK PRI UNVRSL SNGL V2 TAA	" <a href="#">Trade Agreements Act</a> <sup>265</sup> compliant variant.	700515487
IPO IP500 TRNK PRI V2 UNVRSL DUAL	IP Office 500 Trunk Card Primary Rate 2 Universal V2	700515486

Name	Description	SAP Code
IPO IP500 TRNK PRI UNVRSL DUAL V2 TAA	" <a href="#">Trade Agreements Act</a> <sup>285</sup> compliant variant.	700515488

---

## 12.5 IP500 External Expansion Modules

The following IP500 external expansion modules are supported by IP Office Release 12.0. Each module uses an external [power supply unit](#)<sup>230</sup> supplied with the module. A locale specific [power cord](#)<sup>31</sup> for the PSU must be ordered separately.

The external module can be stacked on top of the control unit. They can also be wall or rack mounted using one of the [IP Office mounting kits](#)<sup>237</sup>.

- Systems support up to 8 external expansion modules as standard. If fitted with an IP500 4-Port Expansion Base Card, up to 12 external expansion modules are supported.

### [IP500 Digital Station B/B2 Modules](#)<sup>226</sup>

Provides an additional 16 or 30 RJ45 ports. These can be used as either [DS](#)<sup>262</sup> ports or BST ports. However, the module can only support one port type at any time. For IP Office Release 10.1 the DS16B/DS30B modules have been superseded by the DS16B2/DS30B2 models.

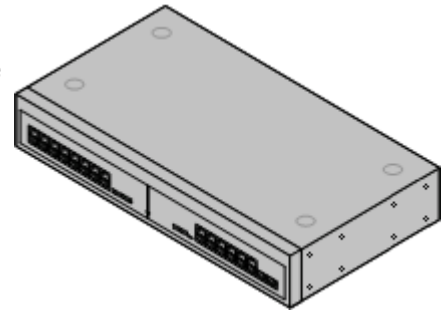

### [IP500 Phone Modules](#)<sup>228</sup>

Provides, depending on variant, an additional 16 or 30 [PHONE](#)<sup>266</sup> ports for connecting analog phones.

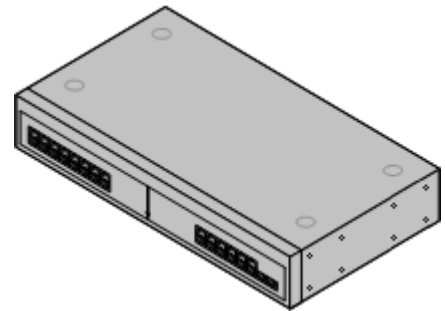

### [IP500 Analog Trunk Module](#)<sup>223</sup>

Provides an additional 16 [ANALOG](#)<sup>259</sup> ports for connection of analog trunks. Supports both loop-start and ground-start trunks.

- Use with ground start trunks requires that the trunk module and the IP Office control unit are grounded.

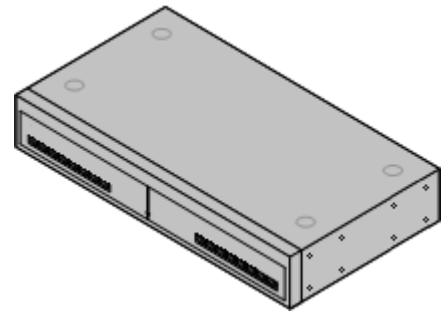

### 12.5.1 Analog Trunk 16

The IP500 Analog Trunk module can be used to add 16 additional analog trunks to an IP Office system. The module supports both loop-start and, with suitable grounding, ground-start trunks.

- In IP Office Basic Edition - PARTNER Mode, IP Office Basic Edition - Norstar Mode and IP Office Basic Editions, only 1 Analog Trunk module is supported.

- **⚠ WARNING**

In all IP Office installations, any module being used for analog trunk connections must be connected to a [functional earth](#)<sup>35</sup>.

- **⚠ WARNING**

Within areas of high lightning risk, any module using analog trunk connections must be connected to a [protective ground](#)<sup>35</sup> and to [surge protection equipment](#)<sup>36</sup>.

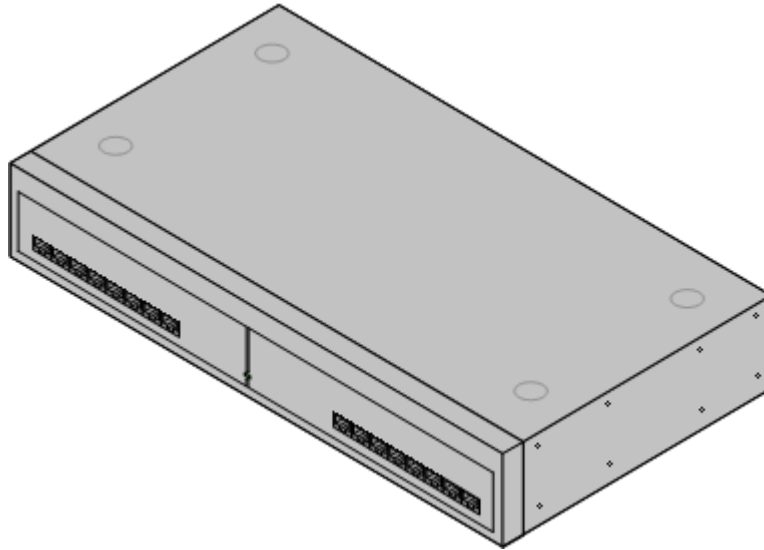

Feature	Details
<b>Locales</b>	This module is currently only supported in North American locales.
<b>Minimum Software Level</b>	IP Office core software level 1.0 minimum. Bin file = naatm16.bin.
<b>Included</b>	Power supply unit (see below) and Expansion Interconnect cable.
<b>Power Supply</b>	The module is supplied with a 2-pin, 40W external power supply unit. The PSU has an integral power cord for connection to the module's DC I/P socket. A locale specific <a href="#">IEC60320 C13 power cord</a> <sup>30</sup> for the external PSU is required but is not supplied with the module.
<b>Mounting</b>	The module is designed as a free-standing module that can be stacked on or under other IP Office modules. The module can be wall or rack mounted using the <a href="#">IPO IP500 RACK MNTG KIT V3</a> <sup>237</sup> .
<b>Dimensions</b>	Width: 445mm/17.5". Depth: 245mm/9.7". Height: 71mm/2.8"/2U.
<b>Weight</b>	Unboxed: 2.9Kg/6.6lbs. Boxed: 4.2Kg/9.4lbs.

#### Module Front

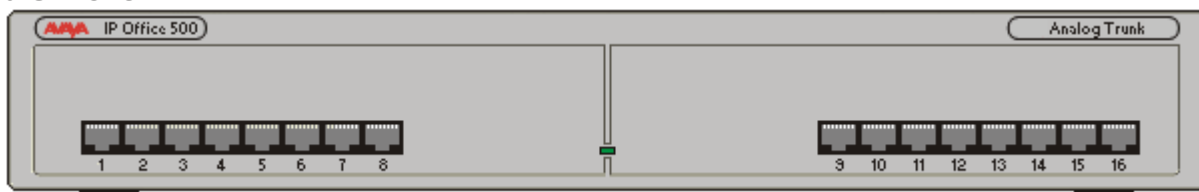

<b>Port LEDs</b>	None
<b>Module Center LED</b>	<p>The center LED on all external expansion modules is used to indicate the overall state of the module as follows:</p> <ul style="list-style-type: none"> <li>• <b>Red flashing</b> = Module starting up/Loading firmware.</li> <li>• <b>Red on</b> = Error.</li> </ul>

- 
- **Green on** = Module okay.

## Module Rear

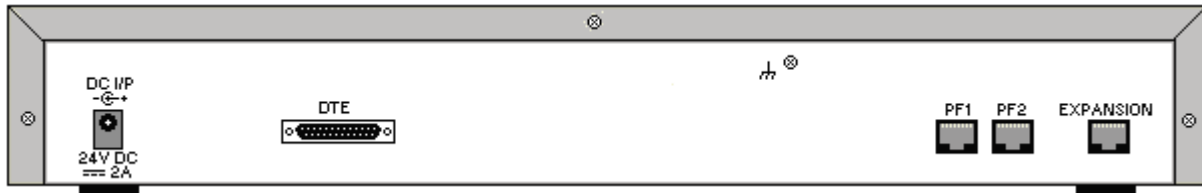

Ports	Description
<b>ANALOG</b> <sup>259</sup>	RJ45 socket. Used for connection to analog trunks. Ports can be configured as either loop-start or ground-start trunks through the IP Office configuration. In the event of power failure, Analog ports 1 and 2 are directly connected to analog extension ports PF1 and PF2 respectively. If used the connected phones must be clearly labeled as power failure devices. This is only supported for loop-start analog trunks.
<b>DC I/P</b> <sup>262</sup>	DC power input port. Used for connection of the power lead from an Avaya 40W external power supply unit supplied with the expansion module. A locale specific <a href="#">IEC60320 C7 power cord</a> <sup>30</sup> for the external PSU is required but is not supplied with the module.
<b>DTE</b> <sup>268</sup>	25-Way D-Type socket. For Avaya use only.
<b>EXPANSION</b> <sup>263</sup>	RJ45 Socket. Used for direct connection to an Expansion port on an IP Office control unit using the Expansion Interconnect cable supplied with the module.
<b>PF</b> <sup>265</sup>	RJ45 socket. Power failure analog extension ports. See Analog section above.
	Ground point. Used for connection of a <a href="#">functional earth</a> <sup>35</sup> if required. On older modules where this screw is not present, the top-center cover screw should be used instead. <ul style="list-style-type: none"> <li>• <b>IMPORTANT</b> In all IP Office installations, any module being used for analog trunk connections must be connected to a <a href="#">functional earth</a> <sup>35</sup>.</li> <li>• <b>⚠ WARNING</b> Within areas of high lightning risk, any module using analog trunk connections must be connected to a <a href="#">protective ground</a> <sup>35</sup> and to <a href="#">surge protection equipment</a> <sup>36</sup>.</li> </ul>

## Part Codes and Related Equipment

All expansion modules are supplied with a base software level and should be upgraded to match the core software of the control unit in the IP Office system. Expansion modules include an external power supply unit (PSU) and an appropriate interconnect cable. They do not include a locale specific power cord for the external PSU or any phone extension cables.

Item	Variant	Country	SAP Code
<b>IPO IP500 EXP MOD ANLG TRNK 16</b>	<b>America</b>	America	700449473
<b>IPO IP500 EXP MOD ANLG TRNK 16 TAA</b>	" <a href="#">Trade Agreements Act</a> <sup>265</sup> compliant variant.	America	700501511
<b>IEC60320 C7 Power Cord</b> 	<b>NEMA1-15</b>	America	700213390
<b>Mounting Kit</b>	<b>IPO IP500 WALL MNTG KIT V3</b>	All	700503160

## 12.5.2 DS16B/30B, DS16B2/30B2

This type of module can be used to add additional RJ45 ports for digital telephones. Through the system configuration, each module is set to either [DS](#)<sup>282</sup> mode for support [Avaya DS digital telephones](#)<sup>39</sup> or BST mode ports for BST digital phones (no longer supported) (DS ports only on IP500 control units).

The modules are available in 16 and 30 port variants, referred to as the IP500 DS16B and IP500 DS30B respectively. The DS16B and DS30B have now been superseded by the DS16B2 and DS30B2 models which provide the same functionality.

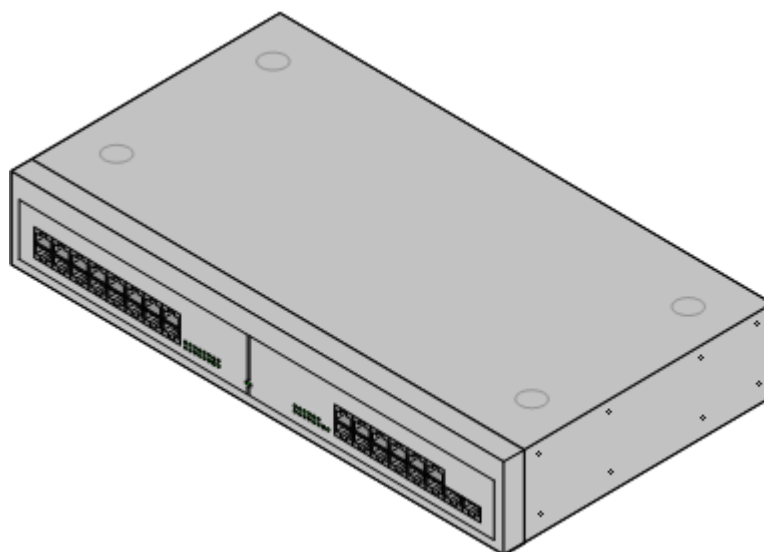

Feature	Details
<b>Locales</b>	Supported in all <a href="#">IP Office locales</a> <sup>17</sup> .
<b>Minimum Software Level</b>	<ul style="list-style-type: none"> <li><b>DS16B/DS30B:</b> IP Office Release 9.0. IP500 (DS only) and IP500 V2 (DS or TCM). For IP Office R8.1 SP9+, these modules only support DS ports.</li> <li><b>DS16B2/DS30B2:</b> IP Office Release 10.1. Also IP Office Release 9.1 SP12 and IP Office Release 10.0 SP5.</li> </ul>
<b>Included</b>	Power supply unit (see below) and Expansion Interconnect cable.
<b>Power Supply</b>	The module is supplied with a Earthed 3-Pin, 60W external power supply module. The PSU has an integral power cord for connection to the module's DC I/P socket. A locale specific <a href="#">IEC60320 C13 power cord</a> <sup>30</sup> for the external PSU is required but is not supplied with the module.
<b>Mounting</b>	The module is designed as a free-standing module that can be stacked on or under other IP Office modules. The module can be wall or rack mounted using the <a href="#">IPO IP500 RACK MNTG KIT V3</a> <sup>237</sup> .
<b>Dimensions</b>	Width: 445mm/17.5". Depth: 245mm/9.7". Height: 71mm/2.8".
<b>Weight</b>	Unboxed: 3.5Kg/7.8lbs. Boxed: 4.8Kg/10.8lbs. (Based on DS30)

- DS16B/DS30B Upgrade Behavior:**  
 For DS16B/DS30B modules, the process of loading the appropriate firmware for the selected mode or upgrading takes up to 10 minutes during which time the module is not available.
- DS16B2/DS30B2 Upgrade Behavior:**  
 The behavior of DS16/30B2 during firmware upgrade or switching modes differs from other external expansion units:
  - During the firmware upgrade, the unit remains operational and can make and receive calls.
  - Once the upgrade is completed (approximately 9 minutes) the unit reboots and takes about 45 seconds to return to normal operation.

## Module Front

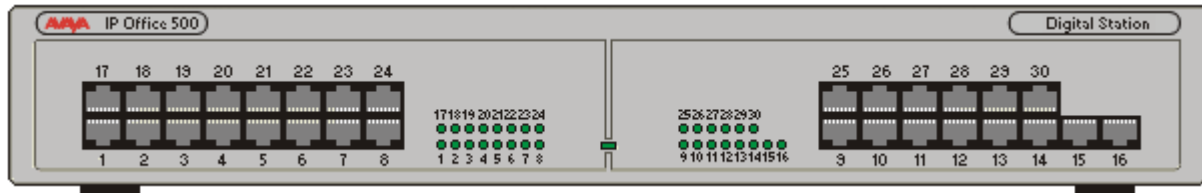

<b>Port LEDs</b>	<ul style="list-style-type: none"> <li>• <b>Green Flashing</b> = Phone detected.</li> <li>• <b>Green On</b> = Phone active.</li> </ul>
<b>Module Center LED</b>	<p>The center LED on all external expansion modules is used to indicate the overall state of the module as follows:</p> <ul style="list-style-type: none"> <li>• <b>Red flashing</b> = Module starting up/Loading firmware.</li> <li>• <b>Red on</b> = Error.</li> <li>• <b>Green on</b> = Module okay.</li> </ul>

## Module Rear

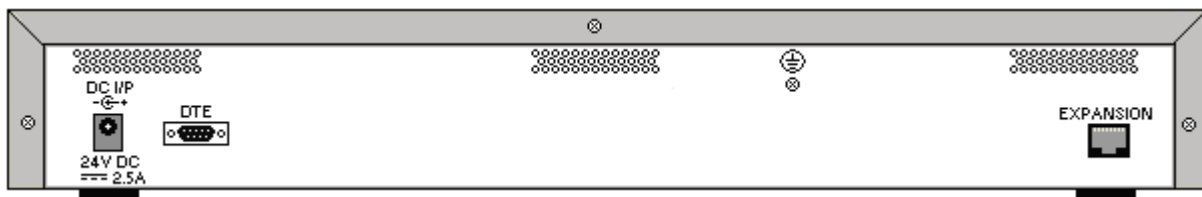

Port	Description
<a href="#">DC I/P</a> <sup>262</sup>	DC power input port. Used for connection of the power lead from an Avaya earthed 60W external power supply unit supplied with the expansion module. A locale specific <a href="#">IEC60320 C13 power cord</a> <sup>30</sup> for the external PSU is required but is not supplied with the module.
<a href="#">DS</a> <sup>262</sup>	RJ45 socket. Digital Station port. Used for connection of IP Office <a href="#">supported DS phones</a> <sup>39</sup> . If connected to an <a href="#">out-of-building extension</a> <sup>36</sup> , the connection must be made via additional IROB barrier devices in addition to the buildings primary protection. The module must also be connected to a protective ground.
<a href="#">DTE</a> <sup>268</sup>	9-Way D-Type socket. For Avaya use only.
<a href="#">EXPANSION</a> <sup>263</sup>	RJ45 Socket. Used for direct connection to an Expansion port on an IP Office control unit using the Expansion Interconnect cable supplied with the module.
	Protective Ground point. Use of a protective ground is required for all installations, see <a href="#">Grounding (Earthing)</a> <sup>95</sup> . Where the module is connected to analog extensions in another building, an IP Office Phone Barrier Box V2 (101V) is required at both ends, see <a href="#">Lightning Protection/Out-of-Building Connections</a> <sup>36</sup> .

## Part Codes and Related Equipment

All expansion modules are supplied with a base software level and should be upgraded to match the core software of the control unit in the IP Office system. Expansion modules include an external power supply unit (PSU) and an appropriate interconnect cable. They do not include a locale specific power cord for the external PSU or any phone extension cables.

Item	Variant	Country	SAP Code
IPO IP500 EXP MOD DS16B DGTL ST	16 Ports	All	700501585
IPO IP500 EXP MOD DS30B DGTL ST	30 Ports	All	700501586
IPO IP500 EXP MOD DS16B2 DGTL ST	16 Ports	All	700511093
IPO IP500 EXP MOD DS30B2 DGTL ST	30 Ports	All	700511094
 IEC60320 C13 Power Cord	CEE7/7	Europe	700289762
	BS1363	United Kingdom	700289747
	NEMA5-15P	America	700289770
Mounting Kit	IPO IP500 WALL MNTG KIT V3	All	700503160

### 12.5.3 Phone 16/30

IP500 Phone modules can be used to add additional PHONE ports to an IP Office system. The module is available in 16 and 30 port variants, referred to as the IP500 Phone 16 and IP500 Phone 30 respectively.

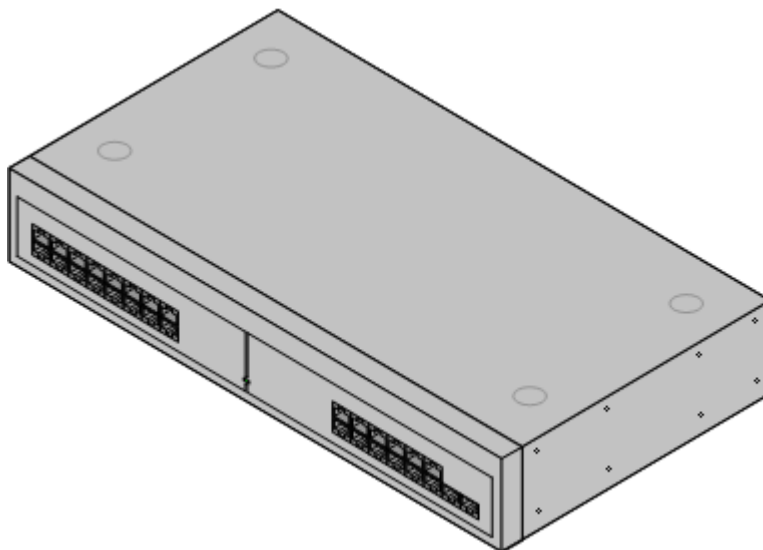

Feature	Details
<b>Locales</b>	Supported in all <a href="#">IP Office locales</a> <sup>17</sup> .
<b>Minimum Software Level</b>	IP Office core software level 2.1(36) minimum. Bin file = dvppots.bin.
<b>Included</b>	Power supply unit (see below) and Expansion Interconnect cable.
<b>Power Supply</b>	The module is supplied with a Earthed 3-Pin, 60W external power supply unit. The PSU has an integral power cord for connection to the module's DC I/P socket. A locale specific <a href="#">IEC60320 C13 power cord</a> <sup>30</sup> for the external PSU is required but is not supplied with the module.
<b>Mounting</b>	The module is designed as a free-standing module that can be stacked on or under other IP Office modules. The module can be wall or rack mounted using the <a href="#">IPO IP500 RACK MNTG KIT V3</a> <sup>237</sup> .
<b>Dimensions</b>	Width: 445mm/17.5". Depth: 245mm/9.7". Height: 71mm/2.8".
<b>Weight</b>	Unboxed: 3.1Kg/6.94lbs. Boxed: 4.4Kg/9.7lbs. (Based on Phone 30 V2)

#### Module Front

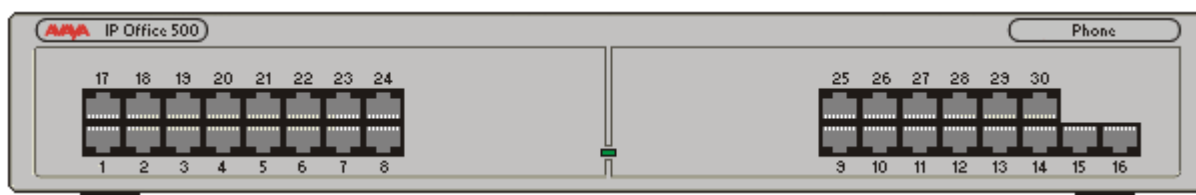

<b>Module Center LED</b>	<p>The center LED on all external expansion modules is used to indicate the overall state of the module as follows:</p> <ul style="list-style-type: none"> <li>• <b>Red flashing</b> = Module starting up/Loading firmware.</li> <li>• <b>Red on</b> = Error.</li> <li>• <b>Green on</b> = Module okay.</li> </ul>
--------------------------	--

## Module Rear

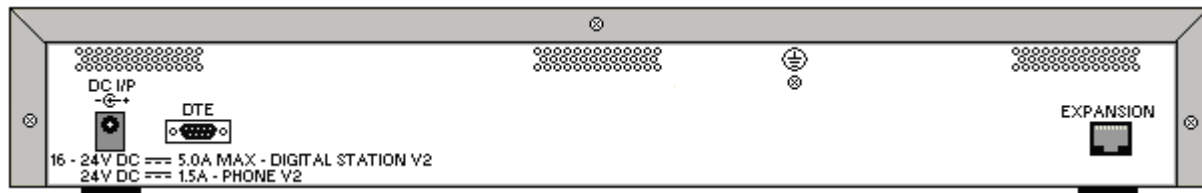

Ports	Description
<a href="#">DC I/P</a> <sup>262</sup>	DC power input port. Used for connection of the power lead from an Avaya earthed 60W external power supply unit supplied with the expansion module. A locale specific <a href="#">IEC60320 C13 power cord</a> <sup>30</sup> for the external PSU is required but is not supplied with the module.
<a href="#">DTE</a> <sup>268</sup>	9-Way D-Type socket. For Avaya use only.
<a href="#">EXPANSION</a> <sup>263</sup>	RJ45 Socket. Used for direct connection to an Expansion port on an IP Office control unit using the Expansion Interconnect cable supplied with the module.
<a href="#">PHONE</a> <sup>266</sup>	RJ45 socket. Used for connection of analog phones. Intended for two-wire analog phones. For connection to 4-wire analog phones connection should be via a master socket with ringing capacitors. If connected to an <a href="#">out-of-building extension</a> <sup>36</sup> , the connection must be made via additional <a href="#">IP Office Barrier Boxes</a> <sup>186</sup> in addition to the buildings primary protection. The module must also be connected to a protective ground.
	Protective Ground point. Use of a protective ground is required for all installations, see <a href="#">Grounding (Earthing)</a> <sup>35</sup> . Where the module is connected to analog extensions in another building, an IP Office Phone Barrier Box V2 (101V) is required at both ends, see <a href="#">Lightning Protection/Out-of-Building Connections</a> <sup>36</sup> .

## Part Codes and Related Equipment

All expansion modules are supplied with a base software level and should be upgraded to match the core software of the control unit in the IP Office system. Expansion modules include an external power supply unit (PSU) and an appropriate interconnect cable. They do not include a locale specific power cord for the external PSU or any phone extension cables.

Item	Variant	Country	SAP Code
<b>IPO IP500 EXP MOD PHONE 16</b>	<b>16 Ports</b>	All	700449507
<b>IPO IP500 EXP MOD PHONE 30</b>	<b>30 Ports</b>	All	700426224
 <b>IEC60320 C13 Power Cord</b>	<b>CEE7/7</b>	Europe	700289762
	<b>BS1363</b>	United Kingdom	700289747
	<b>NEMA5-15P</b>	America	700289770
<b>Mounting Kit</b>	<b>IPO IP500 WALL MNTG KIT V3</b>	All	700503160
<b>IPO PHONE BARRIER BOX (101V) RHS</b>		All	700385495

---

## 12.6 IP400 Expansion Modules

The following IP400 external expansion modules are supported by IP Office Release 12.0 and can be used with IP500 V2 control units.

Each module uses an external [power supply unit](#)<sup>30</sup> supplied with the module. A locale specific [power cord](#)<sup>31</sup> for the PSU must be ordered separately.

### [IP400 Analog Trunk Module \(ATM16\)](#)<sup>231</sup>

Provides an additional 16 [ANALOG](#)<sup>259</sup> ports for connection of analog trunks. Supports both loop-start and ground-start trunks.

- Available in a number of variants for different locales.
- Use with ground start trunks requires that the trunk module and the IP Office control unit are grounded.

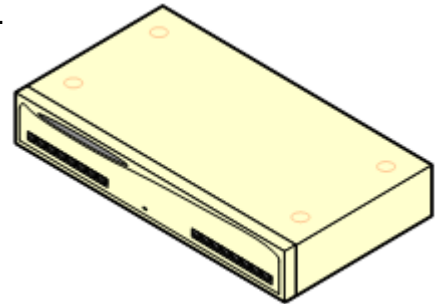

### [IP400 Digital Station Module V2](#)<sup>233</sup>

Provides, depending on variant, an additional 16 or 30 [DS](#)<sup>262</sup> ports for supported [Avaya digital phones](#)<sup>39</sup>. Supersedes the previous Digital Station module.

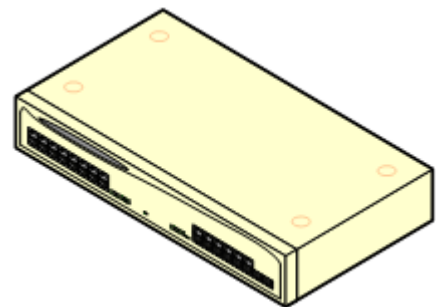

### [IP400 Phone Module V2](#)<sup>235</sup>

Provides, depending on variant, an additional 16 or 30 [PHONE](#)<sup>266</sup> ports for analog phones. Supersedes the previous Phone module. With IP Office 3.1, the Phone V2 supports a wider range of message waiting indication (MWI) options than Phone V1 modules.

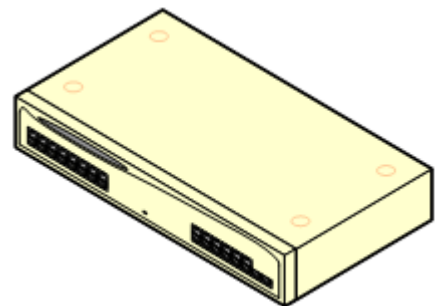

## 12.6.1 Analog Trunk 16

The IP400 Analog Trunk module (also known as the ATM16) is used to add 16 additional analog trunks to an IP Office system. The module supports both loop-start and, with suitable grounding, ground-start trunks.

- ⚠ WARNING**  
 In all IP Office installations, any module being used for analog trunk connections must be connected to a [functional earth](#)<sup>35</sup>.
- ⚠ WARNING**  
 Within the Republic of South Africa and in areas of high lightning risk, any module using analog trunk connections must be connected to a [protective ground](#)<sup>35</sup> and to [surge protection equipment](#)<sup>36</sup>.

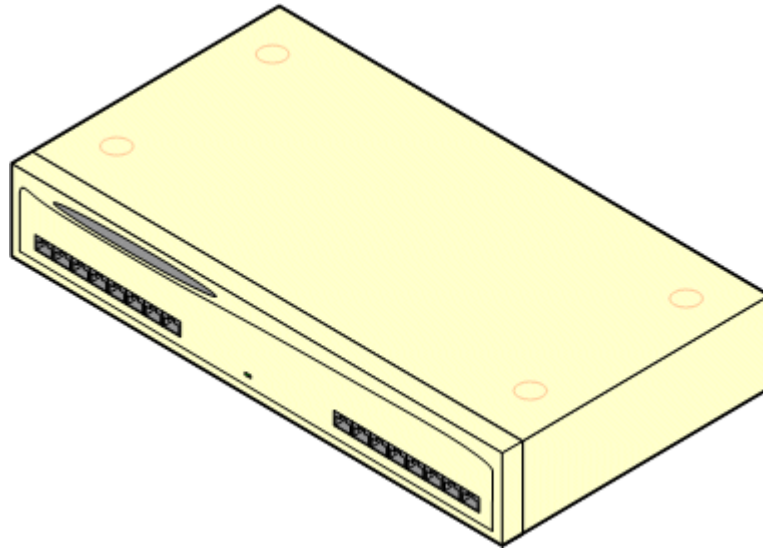

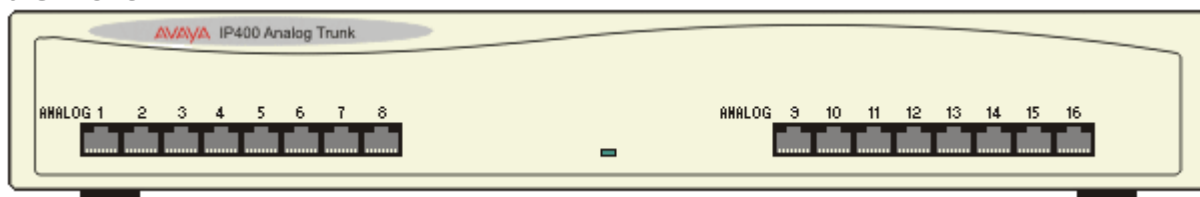

Feature	Details
<b>Locales</b>	Specific variants are provided for different IP Office locales, see below.
<b>Minimum Software Level</b>	IP Office core software level 1.0 minimum. Bin file = naatm16.bin.
<b>Included</b>	Power supply unit (see below) and Expansion Interconnect cable.
<b>Power Supply</b>	The module is supplied with a 2-pin, 40W external power supply unit. The PSU has an integral power cord for connection to the module's DC I/P socket. A locale specific <a href="#">IEC60320 C13 power cord</a> <sup>30</sup> for the external PSU is required but is not supplied with the module.
<b>Mounting</b>	The module is designed as a free-standing module that can be stacked on or under other IP Office modules. The module can be rack mounted in a 19" rack system using the optional IP400 Rack Mounting Kit.
<b>Dimensions</b>	Width: 445mm/17.5". Depth: 245mm/9.7". Height: 71mm/2.8"/2U.
<b>Weight</b>	Unboxed: 2.9Kg/6.6lbs. Boxed: 4.2Kg/9.4lbs.

### Module Front

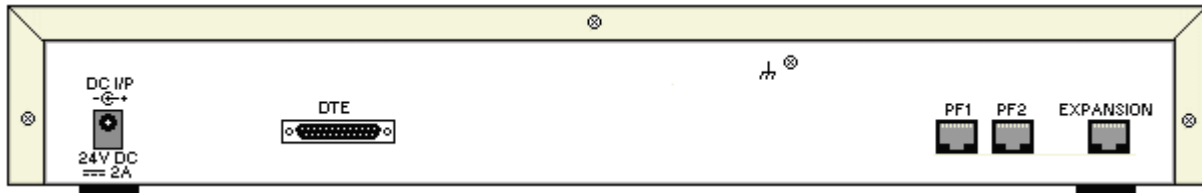

## Module Rear



Ports	Description
<b>ANALOG</b> <sup>259</sup>	RJ45 socket. Used for connection to analog trunks. Ports can be configured as either loop-start or ground-start trunks through the IP Office configuration. In the event of power failure, Analog ports 1 and 2 are directly connected to analog extension ports PF1 and PF2 respectively. If used the connected phones must be clearly labeled as power failure devices. This is only supported for loop-start analog trunks.
<b>DC I/P</b> <sup>262</sup>	DC power input port. Used for connection of the power lead from an Avaya 40W external power supply unit supplied with the expansion module. A locale specific <a href="#">IEC60320 C7 power cord</a> <sup>30</sup> for the external PSU is required but is not supplied with the module.
<b>DTE</b> <sup>268</sup>	25-Way D-Type socket. For Avaya use only.
<b>EXPANSION</b> <sup>263</sup>	RJ45 Socket. Used for direct connection to an Expansion port on an IP Office control unit using the Expansion Interconnect cable supplied with the module.
<b>PF</b> <sup>265</sup>	RJ45 socket. Power failure analog extension ports. See Analog section above.
	Ground point. Used for connection of a <a href="#">functional earth</a> <sup>35</sup> if required. On older modules where this screw is not present, the top-center cover screw should be used instead. <ul style="list-style-type: none"> <li><b>IMPORTANT</b> In all IP Office installations, any module being used for analog trunk connections must be connected to a <a href="#">functional earth</a> <sup>35</sup>.</li> <li><b>WARNING</b> Within the Republic of South Africa and in areas of high lightning risk, any module using analog trunk connections must be connected to a <a href="#">protective ground</a> <sup>35</sup> and to <a href="#">surge protection equipment</a> <sup>36</sup>.</li> </ul>

## Part Codes and Related Equipment

All expansion modules are supplied with a base software level and should be upgraded to match the core software of the control unit in the IP Office system. Expansion modules include an external power supply unit (PSU) and an appropriate interconnect cable. They do not include a locale specific power cord for the external PSU or any phone extension cables.

Item	Variant	Country	SAP Code
<b>IP400 Analog Trunk 16</b>	America	America	700211360
	Europe	Europe	700241680
	New Zealand	New Zealand	700241698
<b>IEC60320 C7 Power Cord</b> 	CEE7/16	Europe	700213382
	BS1363	United Kingdom	700213374
	NEMA1-15	America	700213390
	Korea	Korea	700254519
<b>IP400 Rack Mounting Kit</b>		All	700210800

## 12.6.2 Digital Station V2

The IP400 Digital Station V2 (also known as DS V2) is used to add additional DS ports to an IP Office system. The DS V2 is available in 16 and 30 port variants, referred to as DS16 V2 and DS30 V2 respectively.

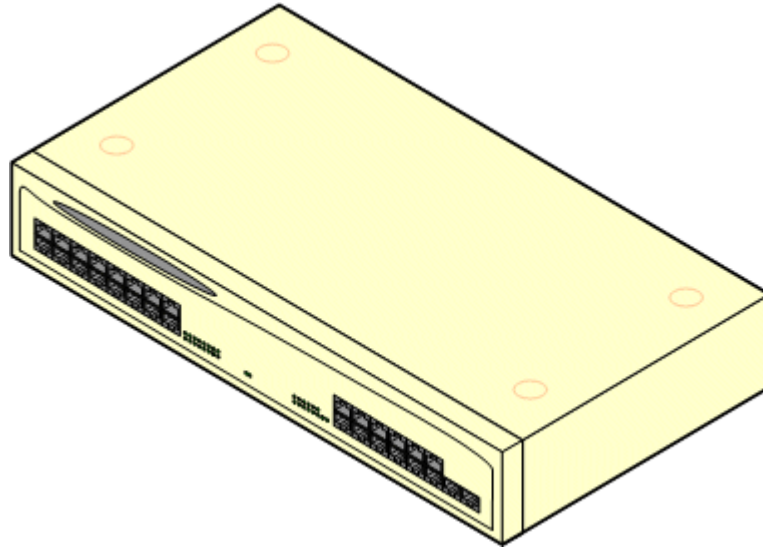

The DS V2 supersedes the original IP400 Digital Station, now referred to as a DS V1. The module version is indicated by labels both the base and the rear of the module.

Feature	Details
<b>Locales</b>	Supported in all <a href="#">IP Office locales</a> <sup>17</sup> .
<b>Minimum Software Level</b>	IP Office core software level 2.1(31) minimum. Bin file = nadcpV2.bin.
<b>Included</b>	Power supply unit (see below) and Expansion Interconnect cable.
<b>Power Supply</b>	The module is supplied with a Earthed 3-Pin, 60W external power supply module. The PSU has an integral power cord for connection to the module's DC I/P socket. A locale specific <a href="#">IEC60320 C13 power cord</a> <sup>30</sup> for the external PSU is required but is not supplied with the module.
<b>Mounting</b>	The module is designed as a free-standing module that can be stacked on or under other IP Office modules. The module can be rack mounted in a 19" rack system using the optional IP400 Rack Mounting Kit.
<b>Dimensions</b>	Width: 445mm/17.5". Depth: 245mm/9.7". Height: 71mm/2.8"/2U.
<b>Weight</b>	Unboxed: 3.5Kg/7.8lbs. Boxed: 4.8Kg/10.8lbs. (Based on DS30 V2)

### Module Front

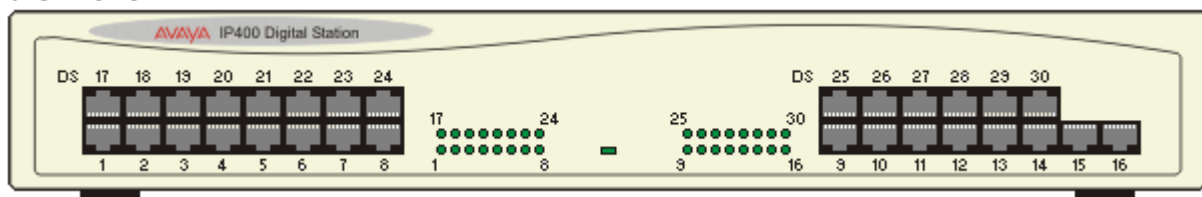

## Module Rear

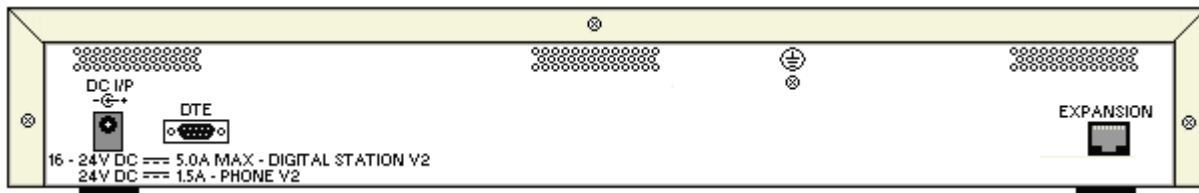

Ports	Description
<a href="#">DC I/P</a> <sup>262</sup>	DC power input port. Used for connection of the power lead from an Avaya earthed 60W external power supply unit supplied with the expansion module. A locale specific <a href="#">IEC60320 C13 power cord</a> <sup>30</sup> for the external PSU is required but is not supplied with the module.
<a href="#">DS</a> <sup>262</sup>	RJ45 socket. Digital Station port. Used for connection of IP Office <a href="#">supported DS phones</a> <sup>39</sup> . If connected to an <a href="#">out-of-building extension</a> <sup>36</sup> , the connection must be made via additional IROB barrier devices in addition to the buildings primary protection. The module must also be connected to a protective ground.
<a href="#">DTE</a> <sup>268</sup>	9-Way D-Type socket. For Avaya use only.
<a href="#">EXPANSION</a> <sup>263</sup>	RJ45 Socket. Used for direct connection to an Expansion port on an IP Office control unit using the Expansion Interconnect cable supplied with the module.
	Protective Ground point. Use of a protective ground is required for all installations, see <a href="#">Grounding (Earthing)</a> <sup>35</sup> . Where the module is connected to analog extensions in another building, an IP Office Phone Barrier Box V2 (101V) is required at both ends, see <a href="#">Lightning Protection/Out-of-Building Connections</a> <sup>36</sup> .

## Part Codes and Related Equipment

All expansion modules are supplied with a base software level and should be upgraded to match the core software of the control unit in the IP Office system. Expansion modules include an external power supply unit (PSU) and an appropriate interconnect cable. They do not include a locale specific power cord for the external PSU or any phone extension cables.

Item	Variant	Country	SAP Code
IP400 Digital Station V2	16 Ports	All	700359839
	30 Ports	All	700359847
 IEC60320 C13 Power Cord	CEE7/7	Europe	700289762
	BS1363	United Kingdom	700289747
	NEMA5-15P	America	700289770
IP400 Rack Mounting Kit		All	700210800

### 12.6.3 Phone V2

The IP400 Phone V2 module (also known as the Phone V2 module) is used to add additional analog PHONE ports to an IP Office system. The Phone V2 module is available in 16 and 30 port variants, referred to as the Phone 16 and Phone 30 respectively.

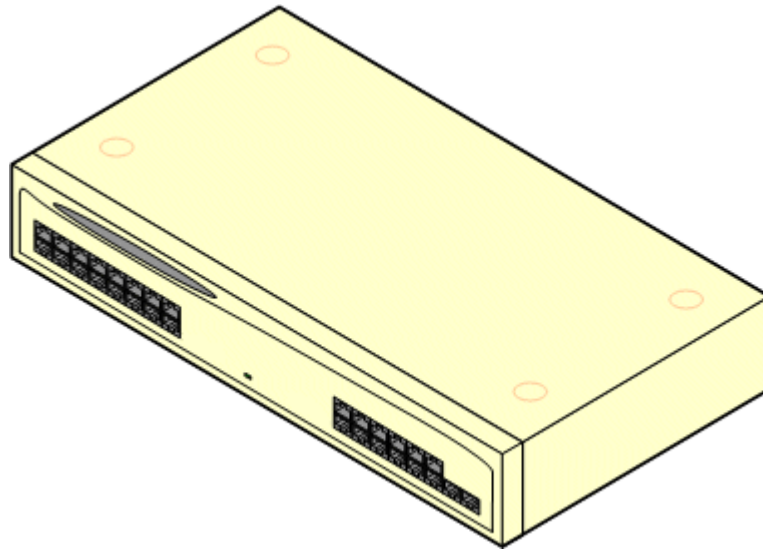

The Phone V2 module supersedes the original IP400 Phone module, now referred to as the Phone V1. The module version is indicated by labels on both the base and the rear of the module. Key changes are:

- The Phone V2 uses an earthed 3-pin 60W external power supply unit.
- With IP Office 3.1, the message waiting indication (MWI) on each port can be configured for **None, On, 51V Stepped, 81V, Line Reversal A or Line Reversal B.** On uses the default determined by the system locale. Ports on a Phone V2 module can additionally be configured for **101V** operation.
- These ports do not include a ringing capacitor. Therefore for connection to 4-wire analog phones, where this is a requirement (typically the United Kingdom and New Zealand), connection should be via a Master socket containing ringing capacitors.
- The DTE serial port on the rear of the module has been changed to a 9-pin D-type socket.

Feature	Details
<b>Locales</b>	Supported in all IP Office locales.
<b>Minimum Software Level</b>	IP Office core software level 2.1(36) minimum. Bin file = dvpots.bin.
<b>Included</b>	Power supply unit (see below) and Expansion Interconnect cable.
<b>Power Supply</b>	The module is supplied with a Earthed 3-Pin, 60W external power supply unit. The PSU has an integral power cord for connection to the module's DC I/P socket. A locale specific <a href="#">IEC60320 C13 power cord</a> <sup>30</sup> for the external PSU is required but is not supplied with the module.
<b>Mounting</b>	The module is designed as a free-standing module that can be stacked on or under other IP Office modules. The module can be rack mounted in a 19" rack system using the optional IP400 Rack Mounting Kit.
<b>Dimensions</b>	Width: 445mm/17.5". Depth: 245mm/9.7". Height: 71mm/2.8"/2U.
<b>Weight</b>	Unboxed: 3.1Kg/6.94lbs. Boxed: 4.4Kg/9.7lbs. (Based on Phone 30 V2)

#### Module Front

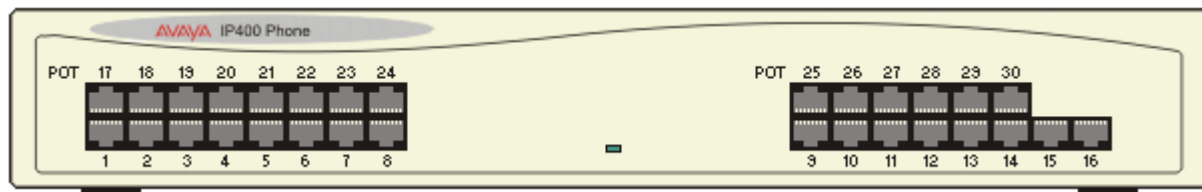

## Module Rear

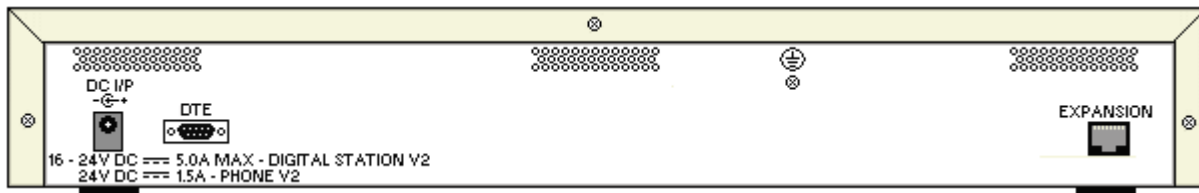

Ports	Description
<a href="#">DC I/P</a> <sup>262</sup>	DC power input port. Used for connection of the power lead from an Avaya earthed 60W external power supply unit supplied with the expansion module. A locale specific <a href="#">IEC60320 C13 power cord</a> <sup>30</sup> for the external PSU is required but is not supplied with the module.
<a href="#">DTE</a> <sup>268</sup>	9-Way D-Type socket. For Avaya use only.
<a href="#">EXPANSION</a> <sup>263</sup>	RJ45 Socket. Used for direct connection to an Expansion port on an IP Office control unit using the Expansion Interconnect cable supplied with the module.
<a href="#">PHONE</a> <sup>266</sup>	RJ45 socket. Used for connection of analog phones. Intended for two-wire analog phones. For connection to 4-wire analog phones connection should be via a master socket with ringing capacitors. If connected to an <a href="#">out-of-building extension</a> <sup>36</sup> , the connection must be made via additional <a href="#">IP Office Barrier Boxes</a> <sup>186</sup> in addition to the buildings primary protection. The module must also be connected to a protective ground.
	Protective Ground point. Use of a protective ground is required for all installations, see <a href="#">Grounding (Earthing)</a> <sup>95</sup> . Where the module is connected to analog extensions in another building, an IP Office Phone Barrier Box V2 (101V) is required at both ends, see <a href="#">Lightning Protection/Out-of-Building Connections</a> <sup>36</sup> .

## Part Codes and Related Equipment

All expansion modules are supplied with a base software level and should be upgraded to match the core software of the control unit in the IP Office system. Expansion modules include an external power supply unit (PSU) and an appropriate interconnect cable. They do not include a locale specific power cord for the external PSU or any phone extension cables.

Item	Variant	Country	SAP Code
IP400 Phone V2	16 Ports	All	700359904
	30 Ports	All	700359912
 IEC60320 C13 Power Cord	CEE7/7	Europe	700289762
	BS1363	United Kingdom	700289747
	NEMA5-15P	America	700289770
IP400 Rack Mounting Kit		All	700210800

## 12.7 Mounting Kits

The following mounting kits are available for use with IP Office systems.

### 12.7.1 IP500 Wall Mounting Kits

IP500 V2 control units and IP500 external expansion modules can be wall or rack mounted. To do this, a wall mounting kit is required in addition to suitable wall fixings.

In addition to the existing [environmental requirements](#)<sup>51</sup> for an IP Office system, the following additional requirements apply when wall mounting a unit:

- The wall surface must be vertical, flat and vibration free. Attachment to temporary walls is not supported.
- Only the screws provided with the mounting kit should be used to attach the brackets to the control unit or expansion modules.
- The installation must be done by a service person.
- Ensure that the system has been shut down and power has been removed from all the units. Shut down the system using a shutdown command and then remove the power. Do not simply remove the power.
- A suitable plywood mounting surface of at least 1m x 1m x 19mm (39" x 39" x 0.75") is required. If an expansion box is being mounted as well a plywood mounting surface of at least 1.2m x 1.2m x 19mm (48" x 48" x 0.75") is required.
- A minimum of 6 x 45mm long 5mm/6mm ( 1.75" #10/#12) pan head screws must be used to secure the plywood to the wall studs.
- The supplied 20mm long 4mm (#8 ¾") wood screws must be used to secure the brackets to the plywood mounting surface

The following kit is currently available:

- **IPO IP500 WALL MNTG KIT V3** (SAP Code 700503160)  
This kit can be used for [wall and rack mounting](#) of IP500 V2 control units and IP500 external expansion modules. The kit incorporates cable routing at the front and rear of the unit. For wall mounted control units, it allows orientation of the control unit base card slots to the left or to the right.

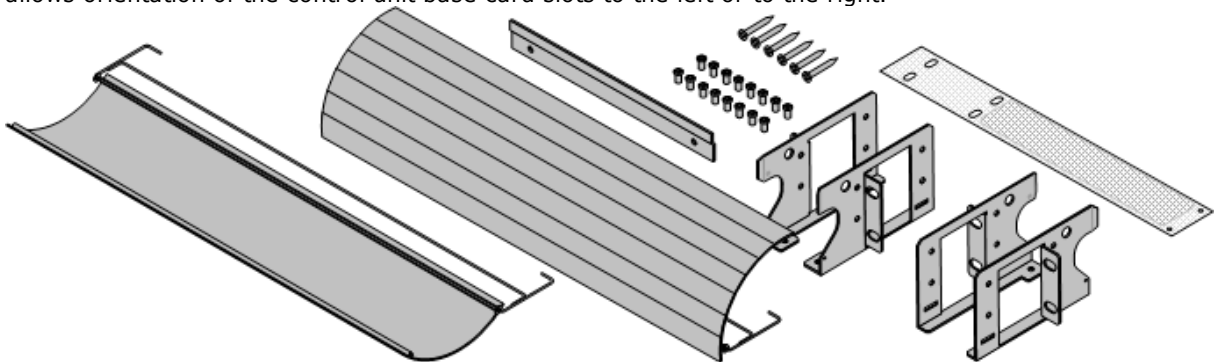

### 12.7.2 Rack Mounting Kit

- **IPO IP500 RACK MNTG KIT** (SAP Code 700429202)  
This kit contains all the components required for the rack mounting of a single IP500 V2 control unit or IP500 external expansion module. This includes screws for fixing of the brackets to the module, bolts for securing the module in the rack and cable tidy brackets..

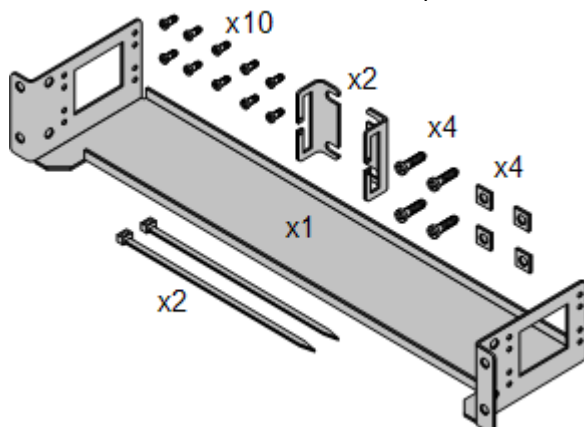

---

### 12.7.3 Barrier Box Rack Mounting Kit

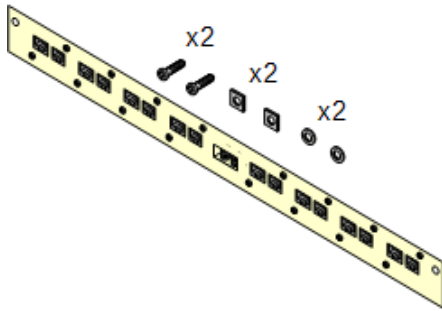

- **Barrier Box Rack Mounting Kit** (SAP 700293905)  
Barrier boxes must be used for [out-of-building analog phone extensions](#)<sup>36</sup>. This bracket allows up to 8 IP Office barrier boxes to be rack mounted and simplifies the number of connections to the protective ground point in the rack. This kit must be used when more than 3 barrier boxes are in use and supports a maximum of 16 barrier boxes for a single external expansion module.

## 12.8 Phones

IP Office Release 12.0 supports the following phones and phone add-ons. Availability may depend on location and may be subject to local restrictions. For historic phone support, see [Hardware/Software Compatibility](#)<sup>260</sup>. For details of button modules, see [Phone Button Modules](#)<sup>240</sup>.

- Note that support

### Avaya DS Digital Telephones (DS Ports)

These digital stations connect to the system via [DS](#)<sup>262</sup> ports.

- **1400 Series:** 1403, 1408, 1416
- **9500 Series:** 9504, 9508

The following additional DS port phones are only supported in IP Office Essential Edition and IP Office Preferred Edition modes:

- **2400 Series:** 2402, 2410, 2420.

### Analog Telephones

Analog phones and devices connect to the system via [PHONE](#)<sup>266</sup>. Due to the variety of analog phones and devices available, no guarantee of operation is given. It is the responsibility of the installer/maintainer to test and verify the operation of proposed analog equipment.

- **6200 Series:** 6211, 6219, 6221 (*North America*).
- **B100 Series:** B149, B159, B169\*.
- **Interquartz Gemini:** 9330-AV, 9335-AV, 9281-AV (*Europe, Middle East, Africa, Asia-Pacific*).

### IP Telephones

IP Phones (SIP and H323) connect to the system via the RJ45 LAN or WAN. These device require an Avaya IP Endpoint license and voice compression resources from the system (see [Voice Compression Channels](#)<sup>41</sup>).

#### H323:

- **1600 Series:** 1603IP/SW, 1608, 1608-I, 1616, 1616-I
- **3700 Series:** 3720, 3725, 3730, 3735, 3745, 3749, 3755, 3759 - Connection via DECT R4 base stations.
- **9600 Series:** 9608, 9608G, 9611G, 9621G, 9641G, 9641GS.

#### SIP:

- **1000 Series:** 1010, 1040
- **1100 Series:** 1120E, 1140E
- **1200 Series:** 1220, 1230
- **B100 Series:** B169\*, B179, B199. (\*The B169 is a DECT phone that connects to a DECT base station. The base station connects to the IP Office via either an analog and SIP base station.)
- **D100 Series:** These DECT handsets (up to 8) use a base station that connects to the IP Office system using a SIP trunk and appear on the IP Office as SIP extensions.
- **H175:** SIP video telephone.
- **H200 Series:** H229, H239, H249.
- **J100 Series:** J129, J139, J159, J169, J179, J189.
- **K100 Series:** K155, K165, K175 including K155 V3 and K175 V3 models.

### Softphone Clients

The following softphone clients are supported with IP Office Essential Edition:

- **Avaya Workplace Client.**
- **IP Office User Portal**

### Other Phones

Whilst non-Avaya analog and IP phones may operate with the system, Avaya will not provide support for those phones. The same also applies to other Avaya phones not specifically supported.

---

## 12.9 Phone Button Modules

The maximum combined number of buttons on button modules per system is 1024.

- **1100 KEM:** +18 (*Max 3 per phone, 56 per system*)  
Add-on for 1120E and 1140E phones. Each module provides 18 additional programmable buttons.
- **1200 KEM:** +12 (*Max 7 per phone, 85 per system*)  
Add-on for 1220 and 1230 phones. Each module provides 12 additional programmable buttons.
- **BM12:** +24 (*Max 3 per phone, 42 per system*)  
Add-on for 9508, 9608, 9611 and 9641 phones. Provides 12 physical buttons assignable in 2 pages for 24 programmable buttons in total. When used with a 9508, power must be supplied to the phone using an inline power module.
- **BM32:** +32 (*Max 3 per phone, 32 per system*)  
Add-on for the 1616 phones that provides two columns of 16 buttons. Up to 3 BM32 modules are supported with any 1616. However, when used with more than one module the telephone must be powered from a power supply unit rather than PoE.
- **JEM24:** +24 (*Max see below*)  
Add-on for the J169, J179 and J189 phones. The modules automatically match the display settings of the phone to which they are connected (color with J179/J189 or greyscale with J169, font size, background image, screen saver). Note that the modules behave differently depending on whether attached to a J169/J179 or a J189:
  - **J169/J179 Telephones** (*Max 3 per phone see below, 14/42 per system*)  
Both the J169 and J179 telephones can support up to 3 JEM24 button modules.
    - A single JEM24 supports 72 programmable button slots. These are arranged in 3-pages, with pages accessed using the module's page scroll button. When in 3-page mode, there is no indication of when programmed button slots not on the page being displayed are alerting. In this mode the module counts as 3 modules for the system's supported capacity.
    - When multiple modules are connected to a phone, each module only supports a single page of 24 programmable button slots and counts as a 1 module for the system's supported capacity.
  - **J189 Telephones** (*Max 2 per phone see below, 14\*/42 per system*)  
A J189 can support up to 2 JEM24 button modules.
    - Each module provides the phone with an additional 24 programmable button slots in a single page. That is, the first module shows buttons 49 to 72, the second buttons 73 to 96. The page scrolling buttons on the modules are disabled.
- To support more than 2 button modules, the phone must use the J100 5V mains power supply unit rather than PoE.
- **DBM32:** +32 (*Max 3 per phone, 32 per system*)  
Add-on for the 1416 phones that provides two columns of 16 buttons. Up to 3 DBM32 modules are supported with any 1416. When used with a DBM32 button module, the telephone must be powered from a power supply unit.
- **EU24:** +24 (*Max 1 per phone, 8 per system*)  
Add-on for the 2420, 4620, 4620SW, 4625, 5620, 5620SW and 5621. Provides an additional 24 programmable buttons. Button display icons are on two switchable pages with 12 icons on each page.
- **EU24BL:** +24 (*Max 1 per phone, 8 per system*)  
As per the EU24 above but with a backlight function to match the 4621. Not supported on the 2420.
- **JBM24:** +24 (*Max 3 per phone, 42 per system*)  
Add-on for the J169 and J179 phones. Each module provides 24 dual-LED programmable buttons with information display adjacent to each button.
  - To support more than 2 button modules, the phone must use the J100 5V mains power supply unit rather than PoE.
  - JEM24 and JBM24 button modules cannot be combined on the same phone.
- **KLM:** +48 (*Max 2 per phone, 21 per system*)  
Used with M7324 phones. Up to 2 buttons modules are supported per phone. Each button module provides 48 programmable buttons.
- **SMB24:** +24 (*Max 3 per phone, 42 per system.*)  
Supported with 9608, 9608G, 9611G, 9641G and 9641GS.
- **T7316E KEM:** +24 (*Max 9 per phone, 42 per system.*)  
Used with T7316E phones. Each button module provides 24 programmable buttons. Up to 4 buttons modules are supported per phone without additional power supply. From 5 to 9 modules can be supported with additional power. Maximum 9 per phone (4 without additional power).



---

## 12.10 Applications

This section outlines the requirements for various IP Office applications. These are just outlines, for full details refer to the specific installation manuals for those applications and to the IP Office Technical Bulletins.

- [Avaya Call Reporting](#)  <sup>243</sup>
- [Avaya Contact Center Select](#)  <sup>243</sup>
- [Embedded Voicemail](#)  <sup>243</sup>
- [Avaya Workplace Client](#)  <sup>244</sup>
- [IP Office Application Server](#)  <sup>245</sup>
- [IP Office Manager](#)  <sup>246</sup>
- [Media Manager](#)  <sup>246</sup>
- [IP Office Web Client](#)  <sup>247</sup>
- [System Monitor](#)  <sup>247</sup>
- [one-X Portal for IP Office](#)  <sup>247</sup>
- [IP Office SoftConsole](#)  <sup>248</sup>
- [System Status Application](#)  <sup>248</sup>
- [TAPI](#)  <sup>249</sup>
- [User Portal](#)  <sup>250</sup>
- [Voicemail Pro](#)  <sup>250</sup>
- [IP Office Ports](#)  <sup>251</sup>

### **12.10.1 Avaya Call Reporting**

Avaya Call Reporting provides call reporting and tracking through a set of 50 standard reports. It can also support a call recording library within the same reporting interface. Visual call center status display is provided through wallboards and agent dashboard displays.

### **12.10.2 Avaya Contact Center Select**

Avaya Contact Center Select is a context-sensitive, collaborative, voice and multimedia solution that allows small to midsize enterprises to anticipate, accelerate and enhance customer interactions. It supports agents using voice, email, web chat, text messaging and fax. It uses the IP Office telephone system to provide a real-time telephony platform.

Customers integrating Avaya Contact Center Select with the IP Office platform gain skill-based routing, call treatments, real-time and historical reporting, unified agent management and the graphical Orchestration Designer utility.

### **12.10.3 Embedded Voicemail**

This is the default voicemail service for IP500 V2 systems. It provides basic voicemail mailbox functions and users and hunt groups. It also supports auto-attendants for handling the routing of calls.

The service uses the System SD card for storing all prompts, voicemail messages, announcements, etc.

Embedded Voicemail supports up to 2 simultaneous connections and 15 hours of storage by default. Additional licenses can enable up to 6 simultaneous connections and 25 hours of storage.

Systems requiring more capacity and customization need to use [Voicemail Pro](#)<sup>250</sup>.

## 12.10.4 Avaya Workplace Client

This is a unified communication application that supports calls, directory contacts, presence, instant messaging and many other features. It is supported as an application on a wide range of operating systems; Windows, Android, macOS and iOS (see [Operating System Support](#)<sup>252</sup> for details).

- iOS support includes iPhone and iPad devices, but not iPod Touch.
- The Android details below do not apply to Vantage K100 Series devices. Refer to the separate Vantage documentation.

On IP500 V2 systems, Avaya Workplace Client is supported for the following users:

User Profile	System Licenses	User Licenses	Mode	OS
<b>Basic User</b>	Essential Edition	Avaya Softphone License	Standalone Mode Only	macOS, Windows
<b>Mobile User</b>	Essential Edition + Preferred Edition	Mobile Worker + Avaya Softphone License		macOS, Windows
<b>Teleworker User</b>	Essential Edition + Preferred Edition	Teleworker	Simultaneous Mode	macOS, Windows
<b>Office Worker User</b>	Essential Edition + Preferred Edition	Office Worker	or Shared Mode	macOS, Windows
<b>Power User</b>	Essential Edition + Preferred Edition	Power User		Android, iOS, macOS, Windows

- **Standalone Mode**

In this mode, Avaya Workplace Client is the users sole telephony device whilst they are logged into Avaya Workplace Client. Logging into Avaya Workplace Client will log them off any other extension. Similarly logging on at another phone will log them out of Avaya Workplace Client.

- **Simultaneous Mode**

In this mode, the user can be logged in on both a physical desk phone and a softphone client such as Avaya Workplace Client at the same time. They can choose to make and answer calls on each extension

- Softphone clients includes Avaya Workplace Client clients.
- Simultaneous client usage was previously only supported if the softphone client registered to the same IP Office on which the user was configured. For R11.0, the softphone client can be registered to any IP Office in the network.

- **Shared Control Mode**

Simultaneous mode Windows and macOS users can put their Avaya Workplace Client client into shared control mode. In that mode, the application is used to make and answer calls via their desk phone.

- Currently only supported for Avaya Workplace Client clients and desk phones registered to the same IP Office server.
- Audio calls only, no video call support.

## 12.10.5 IP Office Application Server

This is not a single application, the IP Office Application Server is a single server installation package for the applications listed below. The DVD installs a CentOS Linux operating system, the IP Office applications and a set of web pages for server management. Note that the installation overwrites any existing operating system and data on the server PC.

- [one-X Portal for IP Office](#) <sup>247</sup>  
User and configuration access is via web browser in the same way as for a Windows server installation of one-X Portal for IP Office.
- [Voicemail Pro](#) <sup>250</sup>  
Configuration access is done using a Windows installation of the Voicemail Pro client software. An installation package for the Voicemail Pro client is included on the IP Office Application Server server.
- [Media Manager](#) <sup>246</sup>  
Voicemail Pro can be used for manual and automatic call recording. Those recordings are placed into mailboxes. Media Manager allows those recordings to be redirected to a separate store where details of each recording are maintained in a searchable database. This allows recordings to be archived, searched and played back separately from mailbox messages. This application requires an IP Office Application Server including additional hard disk for storage of recordings. This application requires entry of a additional licenses into the IP Office configuration.

Details	
DVD	IP Office Application Server Release 12.0 DVD Set (2)
License	Depends on the applications running on the server.

### PC Requirements

Refer to the ["Deploying IP Office Server Edition Servers"](#) manual.

## 12.10.6 IP Office Manager

This tool is used to access all parts of the IP Office configuration. Different levels of access can be defined to control which parts of the configuration the IP Office Manager user can view and alter. IP Office Manager is also used to upgrade the software files used by an IP Office system. When running is also acts as a TFTP server from which some Avaya phones can request new software.

- **IP Office Manager Version**

It is important to download and install the correct version of the IP Office administration suite including IP Office Manager.

- For system installation, you should use the version of IP Office Manager that matches the IP Office release required on the system. This sets the version of software loaded when [recreating the System SD card](#)<sup>177</sup>.
- For system maintenance, the version of IP Office Manager used sets the version of software uploaded to a system when [upgrading the system](#)<sup>177</sup>.
- For system configuration, IP Office Manager Version 12.0 is backwards compatible for systems running software from IP Office Release 6.0 upwards. IP Office Manager cannot load the configuration of an IP Office system running a higher version of software.

- **Admin Lite Not Supported**

Note that the IP Office Manager installed using the **AdminLite** installer is not the full version. It runs in English only and does not include the files needed for actions such as system upgrades, SD card recreation, etc. To fully support systems, ensure that you install the full IP Office Administration suite installer (approximately 1.52GB compared to the 230MB **AdminLite** installer).

Details	
<b>DVD</b>	IP Office Release 12.0 User/Admin DVD (700513659) (Disk 1)
<b>Languages</b>	English, Brazilian, Chinese (Simplified), Dutch, French, German, Italian, Russian, Spanish (Mexican).
<b>License</b>	× No license required.

### PC Requirements

For detailed PC requirements, refer to the appropriate IP Office installation or implementation manual for the application. For general operating system and browser support notes, refer to [Operating System Summary](#)<sup>252</sup>.

## 12.10.7 Media Manager

[Voicemail Pro](#)<sup>250</sup> can be used for manual and automatic call recording. Normally those recordings are placed into the mailbox specified for the user or hunt group whose call is being recorded and are then treated as normal messages. Media Manager allows those recordings to be redirected into a database on the server running Media Manager. This allows recordings to be archived and searched separately from user messages. User access is via web browser.

Media Manager is a service that can be run on an IP Office Application Server which can also host Voicemail Pro and/or one-X Portal for IP Office.

Details	
<b>License</b>	✓ Media Manager. See <a href="#">Voicemail Pro Licenses</a> <sup>274</sup> .

## 12.10.8 IP Office Web Client

This is an Avaya WebRTC client which can be used with IP Office systems. The application is useable by any user licensed and configured for one-X Portal for IP Office and using the Chrome browser on a Windows or macOS PC.

For IP500 V2 installations, it requires the control unit to be supported by one-X Portal for IP Office running from an IP Office Application Server server configured with a WebRTC Gateway service.

For details of installation, refer to the *"Deploying IP Office Server Edition and Application Servers"* manual.

## 12.10.9 System Monitor

System Monitor (also known as Monitor) is a tool that can show all activity on the IP Office system in great detail. As a consequence, interpretation of System Monitor traces requires a high-level of data and telephony protocol knowledge. [System Status Application](#)<sup>248</sup> provides a more easily interpreted view of the system status and events.

All IP Office installers and maintainers must understand how to run the application when necessary as Avaya may request copies of traces to resolve support issues.

Details	
<b>DVD</b>	IP Office Release 12.0 User/Admin DVD (700513659) (Disk 1)
<b>Languages</b>	English only.
<b>License</b>	× No license required.

### PC Requirements

For detailed PC requirements, refer to the appropriate IP Office installation or implementation manual for the application. For general operating system and browser support notes, refer to [Operating System Summary](#)<sup>252</sup>.

## 12.10.10 one-X Portal for IP Office

Users can access the one-X portal from their own PC using a web browser. The application allows the user to control their phones, access voicemail messages, call logs and phone directories.

IP500 V2 systems requiring one-X Portal for IP Office use an [IP Office Application Server](#)<sup>245</sup> server.

Details	
<b>DVD</b>	IP Office Application Server Release 12.0 DVD Set (2)
<b>License</b>	✓ See <a href="#">User Licenses</a> <sup>272</sup> .
<b>Languages</b>	Brazilian Portuguese, Czech, Dutch, English (UK), English (US), French, German, Italian, Japanese, Korean, Polish, Russian, Swedish, Turkish and Latin Spanish.

## 12.10.11 IP Office SoftConsole

This application is intended for telephone system operators or receptionists. It displays details of calls directed to the user and allows them to quickly see the status of the callers required destination and transfer the call. The IP Office SoftConsole user is able to access a range of details about the status of users and groups on the IP Office system.

- The application works in conjunction with an extension phone to provide the speech path for calls.
- Up to 4 simultaneous IP Office SoftConsole users are supported.

Details	
<b>DVD</b>	IP Office Release 12.0 User/Admin DVD (700513659) or Linux server <b>App Center</b> tab.
<b>Languages</b>	Brazilian, Chinese (Simplified), Danish, Dutch, English (UK), English (US), Finnish, French, German, Italian, Korean, Japanese, Latin Spanish, Norwegian, Portuguese, Russian, Spanish and Swedish.
<b>License</b>	✓ Licensed application. See below.

### License

License	Description	RFA Name	SAP
<b>Receptionist</b>	Adds one additional IP Office SoftConsole user. A maximum of four simultaneous IP Office SoftConsole users can be licensed.	IPO LIC RECEPTIONIST RFA	171987

### PC Requirements

For detailed PC requirements, refer to the appropriate IP Office installation or implementation manual for the application. For general operating system and browser support notes, refer to [Operating System Summary](#)<sup>252</sup>.

## 12.10.12 System Status Application

This tool provides a wide range of information about the current status of an IP Office 4.0 or higher system. It includes available resources and components within the system. This includes details of current call in progress. Details of the number of alarms are recorded and the time date of the most recent alarms.

When required for diagnostics escalation SSA is able to take a snap shot image of the IP Office system's status including a copy of its current configuration. Use of SSA requires an IP Office service user name and password that has been configured for System Status access in the IP Office's security settings.

- For IP500 V2 systems, System Status Application is pre-installed on the system's Avaya SD memory card and can be run by browsing to the system's IP address.

Details	
<b>DVD</b>	IP Office Release 12.0 User/Admin DVD (700513659) (Disk 1)
<b>License</b>	× No license required.

### PC Requirements

For detailed PC requirements, refer to the appropriate IP Office installation or implementation manual for the application. For general operating system and browser support notes, refer to [Operating System Summary](#)<sup>252</sup>.

## 12.10.13 TAPI

IP Office TAPI is a client PC application that allows TAPI compliant applications to interact with the IP Office. The IP Office TAPI software can be used in one of two modes. The same software is installed in either case.

- **1st Party TAPI**

In this mode the TAPI software supports control of an individual user's associated extension, allowing a TAPI compliant application to answer (requires a phone that supports handsfree answer) and make calls.

- **3rd Party TAPI**

In this mode, TAPI software on a server can be used to control call functions on multiple user extensions. This mode is used with CTI Developer applications.

Details	
<b>DVD</b>	IP Office Release 12.0 User/Admin DVD (700513659) (Disk 1)
<b>License</b>	Licenses are required for 3rd party TAPI mode operation. See <a href="#">CTI Licenses</a> <sup>275</sup> .

### PC Requirements

For detailed PC requirements, refer to the appropriate IP Office installation or implementation manual for the application. For general operating system and browser support notes, refer to [Operating System Summary](#)<sup>282</sup>.

---

## 12.10.14 User Portal

The user portal is a browser based application provided by the IP Office system. Individual users can use the application to see and change their own telephone settings.

The application can also be used to control the user phone;

- Make and answer calls.
- View the user's call history.
- View the system directory and the user's personal directory.
- View and play voicemail messages.
- View and play call recordings.
- For Linux-based systems, the user portal can be used as a WebRTC softphone for select user profiles.

Which users can use the application and which feature they can access are controlled by settings in the IP Office system configuration.

## 12.10.15 Voicemail Pro

This voicemail service provides greater capacity and call handling customisability over the Embedded Voicemail. The application requires various licenses entered into the IP Office configuration to control the features it offers and the number of simultaneous connections (40).

It also enables support for call recording, text-to-speech (TTS) and a range of other features. IP500 V2 systems requiring Voicemail Pro use an [IP Office Application Server](#)<sup>245</sup> server.

Source	
<b>Languages</b>	Chinese-Mandarin, Chinese-Cantonese, Danish, Dutch, English-UK, English-US, Finnish, French, French-Canadian, German, Greek, Hebrew, Hungarian, Italian, Japanese, Korean, Norwegian, Polish, Portuguese, Portuguese Brazilian, Russian, Spanish, Spanish-Argentinean, Swedish, Turkish.
<b>License</b>	✓ See <a href="#">Voicemail Pro Licenses</a> <sup>274</sup> .

## 12.10.16 IP Office Ports

Details of the range of ports used by IP Office and IP Office applications are found at [https://ipofficekb.avaya.com/businesspartner/ipoffice/mergedProjects/general/port\\_matrix/index.htm](https://ipofficekb.avaya.com/businesspartner/ipoffice/mergedProjects/general/port_matrix/index.htm).

Most PC firewalls requests the user to allow various exceptions when a newly installed application first runs. However this is not always the case, especially if the firewall is located elsewhere than the user's PC.

## 12.11 Operating System Support

This sections summarizes the support for IP Office applications by IP Office Release 12.0.

Some specific features of applications may have additional requirements. Those requirements will be details in the specific installation manual for the application. Unless otherwise stated, the operating system is the latest supported version from the operating system developer.

- o [Windows Support](#)<sup>252</sup>
- o [Android Support](#)<sup>253</sup>
- o [Apple Support](#)<sup>254</sup>
- o [Linux Support](#)<sup>254</sup>
- o [Browser Support](#)<sup>255</sup>

### 12.11.1 Windows Support

The table below list the IP Office applications installable on supported Windows operating system. It does not include [browsable applications](#)<sup>255</sup>.

Server Applications	Windows		Windows Server		
	10	11	2016	2019	2022
<b>MAPI service for Linux Voicemail Pro</b>	-	-	✓	-	-
<b>User Applications</b>					
<b>one-X Portal plug-in for Outlook</b>	✓	✓	-	-	-
<b>" Call Assistant</b>	✓	✓	-	-	-
<b>SoftConsole</b>	✓	✓	-	-	-
<b>TAPI Lite (1st Party)</b>	-	-	-	-	-
<b>TAPI Pro (3rd Party)</b>	✓	✓	✓	-	-
<b>TAPI WAV<sup>[1]</sup></b>	-	-	-	-	-
<b>Maintainer Applications</b>					
<b>IP Office Manager</b>	✓	✓	✓	✓	-
<b>System Monitor</b>	✓	✓	✓	✓	-
<b>System Status Application</b>	✓	✓	✓	✓	-
<b>Voicemail Pro Client</b>	✓	✓	✓	✓	-

1. Windows support is limited to particular business centric versions as follows:
  - Windows 10 and 11 support is only for Pro and Enterprise versions.
  - Windows 2016/2019 support is only for the Standard and Essentials version. Windows 2022 on Standard versions.

### 12.11.1.1 Exchange/Outlook Support

#### Exchange Support

Application\Exchange Server	2016	2019
<b>Voicemail Pro</b>		
• UMS	✓	–
• EWS	✓	✓
• Email Reading <sup>[1]</sup>	–	–
<b>one-X Portal for IP Office</b>		
• Presence	✓	–
• Calendar	–	–
<b>Avaya Workplace Client</b>		
• Calendar	✓	✓

1. Not supported if using EWS integration.

#### Outlook Support

Application\Outlook Version	2016	2019	Office 365
Voicemail Pro UMS/IMAP	✓	✓	–
TAPI Dialing	✓	✓	–
<b>one-X Portal for IP Office</b>			
• Plug-in for Outlook	✓	✓	✓
• Contact Screen Popping	✓	✓	✓

### 12.11.1.2 Terminal Services/VDI Support

The following are the only IP Office™ Platform 12.0 software applications specifically supported in virtualized Windows desktop scenarios. For example: Citrix VDI or Microsoft Terminal Services.

- **one-X Portal for IP Office**  
This includes the one-X Call Assistant and Outlook Plug-in (not with Outlook 2007). Note however that the Outlook Plug-In is only supported in Citrix if using Local profiles.
- **Avaya Workplace Client for Windows**  
Supported from R11.1 FP2 and higher on Citrix and VMware virtual desktop infrastructure (VDI).

### 12.11.2 Android Support

The table below lists the IP Office applications supported Android operating systems. It does not include [browseable applications](#)<sup>[255]</sup>.

IP Office Application	11.0	12.0
<a href="#">Avaya Workplace Client</a> <sup>[244]</sup>	✓	✓

---

### 12.11.3 Apple Support

#### macOS PCs

The table below lists the IP Office applications supported macOS operating systems. It does not include [browseable applications](#)<sup>255</sup>.

Application	11	12
	Big Sur	Monterey
<a href="#">Avaya Workplace Client</a> <sup>244</sup>	✓	✓

#### iPad/iPhone

- [Avaya Workplace Client](#)<sup>244</sup> is supported on iPhone and iPad devices. Not supported on iPod Touch

### 12.11.4 Linux Support

The following IP Office server applications are supported with IP500 V2 systems when run on an [IP Office Application Server](#)<sup>245</sup>. The IP Office Application Server includes the installation of its own operating system.

- **Voicemail Pro**
- **one-X Portal for IP Office**
- **Media Manager**

## 12.11.5 Browser Support

The table below lists the support for IP Office applications which are accessed using a web browser.

Operating System	Windows		-	
	-		macOS	
Application \ Browser	Edge	Firefox	Google Chrome	Safari
one-X Portal for IP Office <sup>[1]</sup>	✓	✓	✓	-
IP DECT R4 Admin	✓	✓	✓	-
D100 DECT Admin	✓	✓	✓	-
IP Office Web Manager	✓	✓	✓	✓
Customer Operations Manager	✓	✓	✓	-
Media Manager Playback (Local and Centralized)	✓	✓	✓	✓
Avaya Spaces Calling	-	-	✓	-
User Portal	✓	✓	✓	✓

### Notes:

1. one-X Portal for IP Office browsing is not supported from Windows server operating systems.

---

## 12.12 Physical Ports

The following port types are found on the IP Office control unit and external expansion modules:

- **ANALOG**<sup>259</sup>  
Used for the connection of external analog trunks.
- **AUDIO**<sup>259</sup>  
Used for input of an external music on hold source.
- **BRI**<sup>261</sup>  
Used for connection of BRI trunks (Quad BRI trunk card). In IP Office standard modes they can also be used for ISDN terminals devices (So8 mode).
- **DC I/P**<sup>262</sup>  
Power input from external power supply unit.
- **DS**<sup>262</sup>  
Connection of Avaya digital station phones supported by IP Office.
- **RS232/DTE**<sup>268</sup>  
Used for control unit maintenance under Avaya guidance. On expansion modules not used.
- **EXPANSION**<sup>263</sup>  
Used for interconnection of external expansions modules and control units.
- **EXT O/P**<sup>188</sup>  
Used to control external relay systems. The port provides two switchable (on, off and pulse) controls.
-   
Used for connection of functional or protective ground if required.
- **LAN**<sup>264</sup>  
10/100Mbps Ethernet LAN ports.
- **PF**<sup>265</sup>  
Analog power fails ports.
- **PHONE**<sup>266</sup> (**POT**)<sup>266</sup>  
Analog phone extension ports. On older units these ports are labeled as POT ports.
- **PRI**<sup>267</sup>  
PRI trunk ports.

## 12.12.1 Cables

The IP Office systems are designed primarily for use within an RJ45 structured cabling system using CAT3 unshielded twisted-pair (UTP) cabling and RJ45 sockets.

A structured cabling system is one where cables are run from a central RJ45 patch panel in the communications/data room to individual RJ45 sockets at user locations. All wires in each cable between the patch panel and the desk socket are connected straight through. This arrangement allows devices connected at the patch panel to be swapped to match the type of device that needs to be connected at the user socket. For example, making one user socket a phone port and another user socket a computer LAN port, without requiring any rewiring of the cables between the patch panel and the user location.

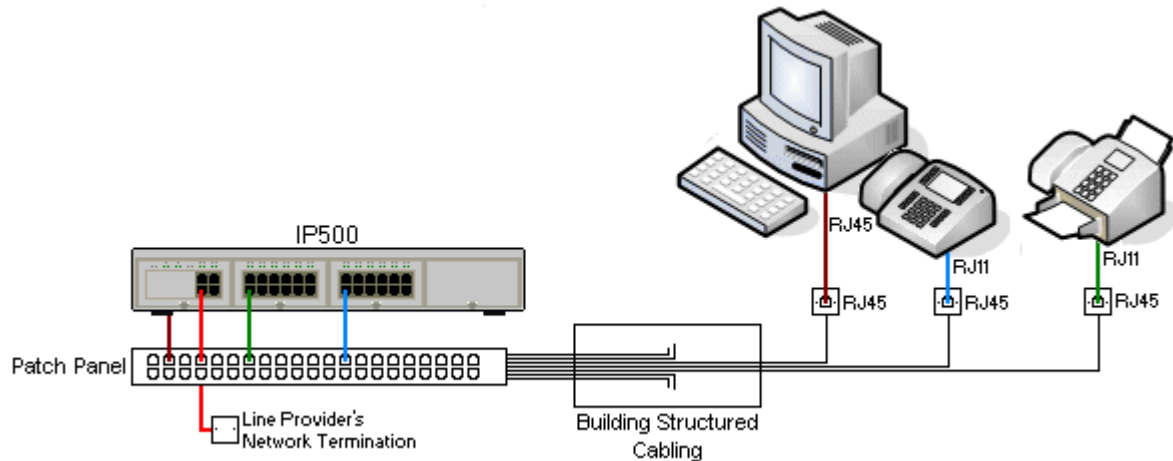

- **Traditional IDC Punchdown Wiring Installations**

Where necessary, the far end RJ45 plug can be stripped from IP Office cables and wired into traditional wiring systems using punch-block connectors. This type of installation should be performed by an experienced wiring technician.

- **Trunk Connections**

The majority of IP Office trunk ports use RJ45 connectors for acceptance of an RJ45-to-RJ45 cable. However, connection at the line provider's end may require use of a different plug type in order to match the line provider's equipment.

- **RJ11 Phone Connectors**

Many phones use RJ11 sockets and are supplied with RJ11-to-RJ11 cables. RJ11 plugs can be inserted into RJ45 sockets and in many cases the connection will work. However, this is not recommended or supported as the connection lock is not truly positive and may become disconnected. An [RJ45-to-RJ11 cable](#)<sup>262</sup> is available for these connections.

## Avaya IP Office Cables

The following are Avaya supplied cables available for use with IP Office systems. The maximum length is applicable if the standard Avaya cable is replaced (if allowed) with an alternate non-Avaya cable.

Cable	Description	SAP Code	Standard Length	Maximum Length
<a href="#">9-Way DTE Cable</a> <sup>268</sup>	Connects to control unit RS232 DTE port. 9-Way D-type plug to 9-way D-type socket.	-	2m/6'6".	2m/6'6".
<a href="#">Structured Cabling DS Line Cable</a> <sup>262</sup>	Connects from RJ45 sockets to RJ11 socketed DS and analog phones.	TT700047871	4m/13'2".	See table below.
<a href="#">BRI/PRI Trunk Cable</a> <sup>261</sup>	Connects BRI/PRI trunk ports to the line provider's network termination point. RJ45 to RJ45. Red.	700213440	3m/9'10".	-
<a href="#">Expansion Interconnect Cable</a> <sup>263</sup>	Connects the control unit to expansion modules. RJ45 to RJ45. Blue. May be replaced by a yellow interconnect cable (2m (6'6") - 700472871) supplied with the <a href="#">IP500 4-Port Expansion</a> <sup>209</sup> card when using that card.	700213457	1m/3'3".	1m/3'3".
<a href="#">LAN Cable</a> <sup>264</sup>	Connects from IP Office LAN ports to IP devices. RJ45 to RJ45. Grey.	700213481	3m/9'10".	100m/328'.

The table below details the maximum total cable distances for non-IP extensions using different cable thicknesses. Cabling should be Category-1 unshielded twisted pair cable or better.

Telephone	Unshielded Twisted-Pair (UTP) - 50nf/Km		
	AWG22 (0.65mm)	AWG24 (0.5mm)	AWG26 (0.4mm)
1400 Series	1200m/3937'	1000m/3280'.	670m/2200'
9500 Series	1200m/3937'	1000m/3280'	670m/2200'
Analog Phones	1000m/3280'	1000m/ 3280'	400m/1312'

## 12.12.2 ANALOG Port

These ports are analog trunk ports. IP500 analog trunk cards only support loop-start trunks. The [ATM16 Analog Trunk](#)<sup>23</sup> module supports both loop-start and ground-start trunks, switchable within the IP Office configuration.

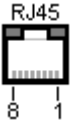
ANALOG	Pin	Description
	1	Not used.
	2	Not used.
	3	Not used.
	4	Ring.
	5	Tip.
	6	Not used.
	7	Not used.
	8	Not used.

- **Off-Hook Current:** 25mA.
- **⚠ IMPORTANT**  
In all IP Office installations, any module being used for analog trunk connections must be connected to a [functional earth](#)<sup>35</sup>.
- **⚠ WARNING**  
Within the Republic of South Africa and in areas of high lightning risk, any module using analog trunk connections must be connected to a [protective ground](#)<sup>35</sup> and to [surge protection equipment](#)<sup>36</sup>.

## 12.12.3 AUDIO Port

This port is found on the rear of all IP Office control units. It is used for the input of an external music-on-hold sound source. Note that if the IP Office has loaded an internal music-on-hold sound file, any input from this socket is ignored.

The port is a 3.5mm stereo jack socket suitable for use with the most standard audio leads and connection to the 'headphone' output socket of most audio systems.



The use of a 'headphone' socket allows simple volume adjustment. Connection via a 'Line Out' socket may require additional equipment in order to adjust the volume level.

Pin No.	Description
Common	● Common
Left	◀ Audio In - Left Channel.
Right	◀ Audio In - Right - Channel.

- Input impedance: 10k /channel. Maximum a.c. signal – 200mV rms.

## 12.12.4 BRI Port (So)

For IP Office 4.2+, IP500 BRI trunk daughter cards can be switched from To to So mode.

IP Office			Wire	ISDN Terminal	
RJ45	Pin	BRI		PIN	RJ45
	1	-	White/Orange	1	
	2	-	Orange/White	2	
	3	←Rx-A	White/Green	3	
	4	→Tx-B	Blue/White	4	
	5	→Tx-A	White/Blue	5	
	6	←Rx-B	Green/White	6	
	7	-	White/Brown	7	
	8	-	Brown/White	8	

### • Terminating Resistors

100ohm Terminating resistors are required across the transmit and receive wire pairs at each end of the S-bus.

- For IP Office 4.2+, individual ports of an IP500 BRI daughter card can be switched to So mode. This is done by setting the **Line Sub-Type** to **S-Bus** in the IP Office configuration. In this case, terminating resistors must be added at the IP Office end in addition to those at the other end of the S-bus connection.
  - Addition of the necessary termination at the IP Office end can be done using an IP500 BRI So Converter Cable (700458649). This short (25cm/10") cable includes both the necessary terminating resistors and the cable cross-over.
- Many ISDN terminal devices includes terminating resistors. If this is not the case, 100ohm (+/-5%) resistors must be connected across the receive wire pair and the transmit wire pair in the junction box immediately before the last ISDN terminal on the S-bus.

## 12.12.5 BRI Port (To)

These ports are BRI To interface ports for connection to external BRI trunk services.

### PRI/BRI Trunk Cable

This cable is used to connect from IP Office BRI/PRI trunk ports to the line providers network termination equipment. If that equipment does not use RJ45 sockets, the cable may need to be stripped and rewired or an alternate cable used. The appropriate signal pin-outs and wire colours are detailed below.

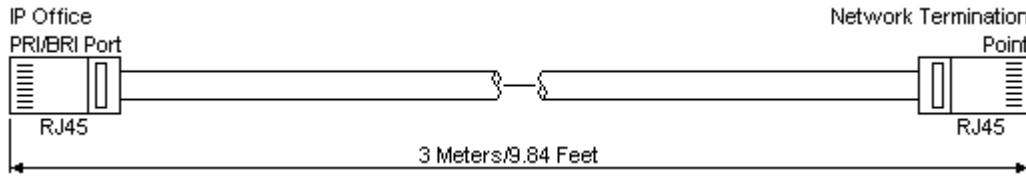

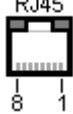
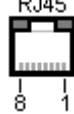
IP Office				Wire	Network Termination	
BRI	RJ45	BRI	PRI		PIN	RJ45
 8 1	1	-	←Rx-A	White/Orange	1	 8 1
	2	-	←Rx-B	Orange/White	2	
	3	→Tx-A	-	White/Green	3	
	4	←Rx-A	→Tx-A	Blue/White	4	
	5	←Rx-B	→Tx-B	White/Blue	5	
	6	→Tx-B	-	Green/White	6	
	7	-	-	White/Brown	7	
	8	-	-	Brown/White	8	

- Supply: BRI/PRI trunks cards are not supplied with these cables.
- Cable Color: Red.
- SAP Code: 700213440.
- Standard Length: 3m/9'10".
- Maximum Length: 5m/16'5".
- Though not used pins 7 and 8 are through connected for ease of construction.

## 12.12.6 DC I/P Port

Found on all IP Office control units and expansion modules. Used for connection from the external [power supply unit](#)<sup>30</sup> supplied with the control unit or module.

- No other type of power supply unit should be used with the module or module unless specifically indicated by Avaya.
- Power cords must not be attached to the building surface or run through walls, ceilings, floors and similar openings.

## 12.12.7 DS Ports (RJ45)

These ports are used for connection from an RJ45 structured cabling system to digital station phones supported by the IP Office. DS ports are provided by [IP500 Digital Station Cards](#)<sup>213</sup>, [IP500 ATM Combination Cards](#)<sup>211</sup> and [IP500 Digital Station](#)<sup>226</sup> external expansion modules.

Though the RJ11 to RJ11 cables supplied with some phones can be plugged directly into RJ45 ports including those on IP Office modules, this is not recommend as the connection lock is not positive and may become disconnected.

- DS ports on external expansion modules can be connected to [out-of-building extensions](#)<sup>36</sup>. If this is the case, connection must be made via suitable protective devices at each end and via each building primary protection. In addition, the Digital Station module must be connected to a protective ground.
- DS ports on base cards within the control unit must not be connected to out-of-building extensions.

### Structured Cabling Line Cord

This is an RJ45 to RJ11 cable suitable for connection from a structured cabling system RJ45 port to a DS phone. It can also be used for two-wire analog phone extensions.

This cable is not suitable for connection from an Avaya 1151D1/B2 power supply unit to a DS phone with a EU24 or XM24 add-on module. In those cases the cables supplied with the power supply unit and the add-on module should be used.

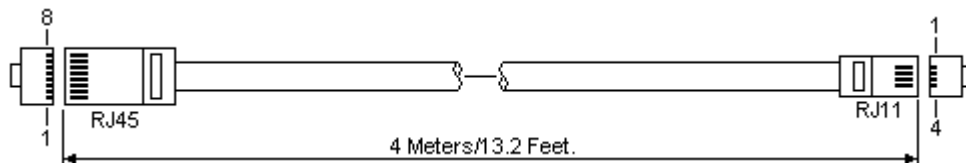

IP Office			Phone	
DS Port	Pin	Description	Pin	Port
	1	Not used.	-	
	2	Not used.	1	
	3	Not used.	2	
	4	Signal 1.	3	
	5	Signal 2.	4	
	6	Not used.	5	
	7	Not used.	6	
	8	Not used.	-	

- SAP Code: T700047871.

### 12.12.8 EXPANSION Port

This type of port is found on the rear of IP Office control units and external expansion modules. It is used for connecting the external expansion modules to their parent IP Office control unit.

The connection between these ports should only be done using an Avaya Expansion Interconnect Cable. No other cable type should be used.

- Each external expansion module is supplied with a blue 1 meter (3'3") expansion interconnect cable. This cable must be used when connecting to expansion ports on the rear of a control unit.
- When connecting to expansion ports on an IP500 4-Port Expansion card, a supplied yellow 2 meter (6'6") expansion interconnect cable can be used in place of the supplied blue cable. 4 Yellow cables are supplied with the IP500 4-Port Expansion card.

#### Expansion Interconnect Cable

The Expansion Interconnect cable is used to link expansion ports between the IP Office control unit and external expansion modules.

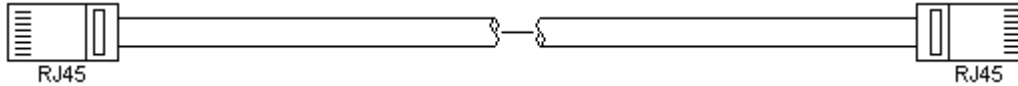

- Supply: One cable is normally supplied with each external expansion module.
- SAP Code: 1m (3'3") Blue cable - 700213457, 2m (6'6") Yellow cable - 700472871.

### 12.12.9 EXT O/P Port

These ports are found on the rear of all IP Office control units. They are used for connection to external switching relays. The port uses a standard 3.5mm stereo jack plug for connection.

The IP Office is able to open (high resistance), close (low resistance) or pulse (close for 5 seconds and then open) two switches within the port. Either switch can be operated separately. These switches are intended for activation of external relays in systems such as door opening systems.

- **CAUTION:**  
In installations where this port is connected to a device external to the building, connection must be via a MDS2 Surge Protector and a protective ground connection must be provided on the IP Office control unit. When using the MDS2 on the Ext O/P port, use only the Line 1 and Equipment 1 jacks, do not use the Line 2 or Equipment 2 jacks.

EXT O/P	Pin	Description
	1	Switch 1.
	2	Switch 2.
	3	0 Volts (Ground/Chassis)

- Switching Capacity: 0.7A.
- Maximum Voltage: 55V d.c.
- On state resistance: 0.7 ohms.
- Short circuit current: 1A.
- Reverse circuit current capacity: 1.4A.
- Ensure that pins 1 and 2 are always at a positive voltage with respect to pin 3.

3.5mm stereo audio jack plugs are frequently sold as pre-wired sealed modules. It may be necessary to use a multi-meter to determine the wiring connections from an available plug. Typically 3 (common to both relays) is the cable screen.

## 12.12.10 LAN Port

These ports are found on IP Office control units. They are used for connection to IP LANs and IP devices.

All IP Office LAN ports are 10/100Mbps auto-sensing. The ports are full-duplex 10/100Mbps auto-sensing, MDI crossover ports. They form a managed layer 3 Ethernet switch.

The WAN port is not supported on systems running in IP Office Essential Edition mode.

The LEDs are used as follows:

- Green: On = connected, Flashing = Activity.
- Yellow: On = 100Mbps, Off = 10Mbps.

### LAN Cables

These are CAT5 UTP cables for connection of various IP devices within the IP Office system.

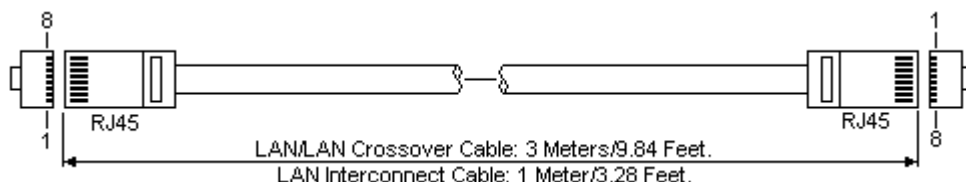

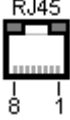
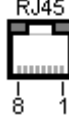
IP Office							
LAN	Pin	MDIX (Normal)	MDI (Crossover)	Wire	Standard/ Interconnect	Crossover	
	1	← Rx-A.	→ Tx-A.	White/Orange	1	3	
	2	← Rx-B.	→ Tx-B.	Orange/White	2	6	
	3	→ Tx-A.	← Rx-A.	White/Green	3	1	
	4	Not used.	Not used.	Blue/White	4	4	
	5	Not used.	Not used.	White/Blue	5	5	
	6	→ Tx-B.	← Rx-B.	Green/White	6	2	
	7	Not used.	Not used.	White/Brown	7	7	
	8	Not used.	Not used.	Brown/White	8	8	

#### • SAP Code:

- **LAN Cable - GREY: 700213481.**  
Standard straight LAN cable.
- **LAN Crossover Cable - Black: 700213473.**  
LAN crossover cable.

## 12.12.11 PF Port

These ports are found on the rear of the [Analog Trunk 16 expansion module](#)<sup>23</sup>. They are analog extension ports that can be used in conjunction with analog loop-start trunks during power failure to the IP Office system. See also [Emergency and Power Failure Ports](#)<sup>47</sup>.

Any phones connected to these ports should be clearly labeled as power fail extensions in accordance with the appropriate national and local regulatory requirements.

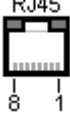
PF	Pin	Description
	1	Not used.
	2	Pin 2 is internally connected to pin 5 via a ringer capacitor.
	3	Not used.
	4	Ring.
	5	Tip.
	6	Pin 6 is internally connected to pin 5 via a ringer capacitor.
	7	Not used.
	8	Not used.

- Minimum Wire Size: AWG 26.
- Maximum Cable Length:
  - AWG26: 500m / 1640'.
  - AWG24, AWG22: 1000m / 3280'.

## 12.12.12 PHONE (POT) Port

These ports are analog extension ports. On older IP Office units these ports were labeled as POT ports rather than PHONE ports.

PHONE ports on Phone V1/V2 expansion modules can be connected to [out-of-building extensions](#)<sup>36</sup>. If this is the case, connection must be made via suitable protective devices (IP Office Barrier Box) at each end and via each building primary protection. In addition the Phone module must be connected to a protective ground.

PHONE ports on IP Office control units must not be connected to out-of-building extensions.

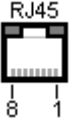
PHONE	Pin	Description
	1	Not used.
	2	Not used.
	3	Not used.
	4	Ring.
	5	Tip.
	6	Not used.
	7	Not used.
	8	Not used.



- REN: 2
- Off-Hook Current: 25mA.
- Ring Voltage:
  - IP500 V2 Control Unit, IP500 Phone Modules: 49V rms.
- Minimum Wire Size: AWG 26.
- Maximum Cable Length:
  - AWG26: 0.5km / 1640 feet.
  - AWG24, AWG22: 1km / 3280 feet.

These ports do not include a ringing capacitor. Therefore, for connection to 4-wire analog phones where this is a requirement (typically the United Kingdom and New Zealand), connection should be via a Master socket containing ringing capacitors.

### Structured Cabling Line Cord

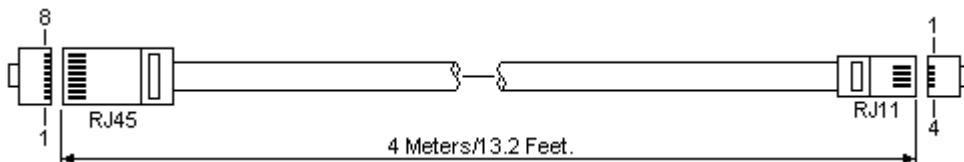
This is an RJ45 to RJ11 cable suitable for connection from a structured cabling system RJ45 port to a DS phone. It can also be used for two-wire analog phone extensions.

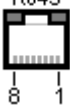

IP Office		Phone		
DS Port	Pin	Description	Pin	Port
	1	Not used.	-	
	2	Not used.	1	
	3	Not used.	2	
	4	Signal 1.	3	
	5	Signal 2.	4	
	6	Not used.	5	
	7	Not used.	6	
	8	Not used.	-	

### 12.12.13 PRI Port

These ports are used for connection to PRI trunk services including E1, T1 and E1-R2.

#### PRI Trunk Cable

This cable is used to connect from IP Office PRI trunk ports to the line providers network termination equipment. If that equipment does not use RJ45 sockets, the cable may need to be stripped and rewired or an alternate cable used. The appropriate signal pin-outs and wire colours are detailed below.

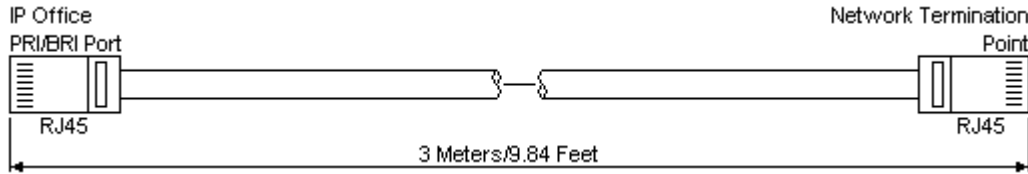

IP Office		Wire	Network Termination		
RJ45	PRI		PIN	RJ45	
	1	← Rx-A	White/Orange	1	
	2	← Rx-B	Orange/White	2	
	3	-	White/Green	3	
	4	→ Tx-A	Blue/White	4	
	5	→ Tx-B	White/Blue	5	
	6	-	Green/White	6	
	7	-	White/Brown	7	
	8	-	Brown/White	8	

- Supply: PRI trunks cards are not supplied with these cables.
- Cable Color: Red.
- SAP Code: 700213440.
- Standard Length: 3m/9'10".

## 12.12.14 RS232 Port (DTE)

These ports are found on the rear of all IP Office control units and external expansion modules. The similar ports on external expansion modules are only used by Avaya.

The RS232 DTE ports can be used for a number of [system maintenance processes](#)<sup>195</sup>. An asynchronous terminal program such as HyperTerminal is also required. Configure this for operation via a PC serial port, as follows:

- **Bits per second:** 38400
- **Data bits:** 8
- **Parity:** None
- **Stop bits:** 1
- **Flow control:** None
- **Settings | Emulation:** TTY

### DTE Cables

These cables are used for system maintenance and diagnostics under Avaya guidance. They can also be used for connection of RS232 serial terminal adaptor equipment to the IP Office control unit. The cable required depends on the IP Office control unit. This cable is a "Straight through DB9 female to DB9 male serial cable".

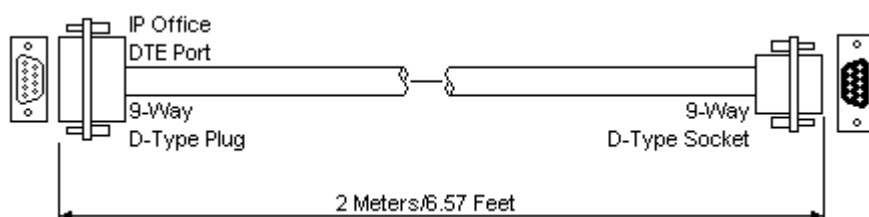

IP Office 9-Way RS232 DTE Port	Signal	PC/Terminal Adaptor
3	← Receive data	3
2	→ Transmit Data	2
7	← RTS (Request To Send)	7
8	→ CTS (Clear To Send)	8
6	→ DSR (Data Set Ready)	6
5	■ Ground	5
1	→ DCD (Data Carrier Detect)	1
4	← DTR (Data Terminal Ready)	4
9	→ RI (Ring Indicator)	9

## 12.13 Licences

This section covers licenses used IP500 V2 IP Office systems running IP Office Release 12.0. It does not include details of licenses used for other types of IP Office systems such as Server Edition.

The IP Office system requires licenses for some features, see [Licenses](#)<sup>299</sup>. The license file can be either uploaded manually or [pre-loaded onto the System SD card](#)<sup>300</sup>.

### How is the system licensed?

- An XML file containing the full set of PLDS licenses is uploaded to the system. The license file is unique to the feature key serial number of the System SD card installed in the system.
- The card's ID number is printed on the card's label after **PLDS ID**, **FK SN** or **FK** depending on the age of the card. On newer cards is a 12-digit number. Older cards may have a 10-digit number. For PLDS licensing, use the 12-digit number. On older cards, for licensing, prefix the 10-digit number with **11**.

### Minimum License Requirements

For IP Office Essential Edition, the system requires an **Essential Edition** system license for the specific IP Office release you want it to run.

### Upgrade Licensing

From IP Office Release 10.0 onwards, the PLDS XML license file is release-specific. For a system to be upgraded to a new major release of IP Office software, a new license file specific to the target release is required. This applies even if the file contains the same set of licenses.

## 12.13.1 System Edition Licenses

These license are used to set what range of features the IP Office system supports.

- **Essential Edition :**  
The system requires this license to run in IP Office Essential Edition mode. Until entered, the system shows unlicensed on phone displays.
  - This license is also a pre-requisite to the **Preferred Edition** license.
  - This license enables embedded voicemail with up to 2 simultaneous connections and 15 hours of storage.
- **Essential Edition Additional Voicemail Ports :**  
This license enables two additional embedded voicemail connections and an additional 5 hours of storage. Multiple licenses can be added for a maximum of up to 6 connections and 25 hours storage.
- **Preferred Edition (Voicemail Pro) :**  
This license enables support for Voicemail Pro as the IP Office's voicemail server with 4 voicemail ports. The **Preferred Edition** license allows the voicemail server to provide the services listed below. For IP Office Release 8.0 and higher, an **Essential Edition** license is a pre-requisite for this license on IP500 V2 systems.
 

• Mailboxes for all users and hunt groups.	• Campaigns.
• Announcements for users and hunt groups.	• TTS email reading for users licensed to <b>Mobile Worker</b> or <b>Power User</b> profiles. Also requires TTS licenses.
• Customizable call flows.	• Use of <b>Conference Meet Me</b> functions.
• Call recording to mailboxes.	• Database access
- 1. A [Preferred Edition](#)<sup>299</sup> system license is a pre-requisite for any user profile license other than **Basic User**.
  - In a Small Community Network, the **Preferred Edition** license of the central system is automatically shared with other systems in the network, enabling user profile licenses on those other systems. However, each system supporting a Voicemail Pro server, for example for distributed voicemail, still requires its own **Preferred Edition** license.
- **Branch System**  
This license enables support for enterprise branch features. These relate to an IP Office system being used as a branch site switch in an Avaya Aura network. Additional **SM Trunk** licenses are required for the SM lines configured between the branch and the Avaya Aura.

---

## 12.13.2 Upgrade Licenses

Existing IP Office systems being upgraded to IP Office Release 12.0 require a software upgrade license.

- **! Warning: Upgrade License Requirements**

On a new system, when the first call is made, the software level being run is written into the control unit's permanent memory. Any subsequent upgrade to a higher release requires the addition of the **Essential Edition** license for the target release. Systems upgraded without that license display *"No license available"* on some phones and will not allow any telephony functions.

- **! Note: Server Edition Systems**

IP500 V2 control units configured as IP500 V2 Expansion System systems are licensed and upgraded through the Server Edition web management menus. Refer to the Server Edition documentation.

## 12.13.3 Trunk Licensing

The following trunks licenses can be used by a IP Office Essential Edition system.

- **IP500 Universal PRI (Additional channels)**

These licenses are used to enable additional B-channels above the basic 8 on an IP500 PRI-U card. The IP500 PRI-U card supports E1, T1 and E1-R2 PRI modes. The IP Office system supports 8 unlicensed B-channels on each IP500 PRI-U port fitted. Additional B-channels, up to the capacity of ports installed and PRI mode selected require licenses. These additional channels consume licenses based on which additional channels are configured as in-service from port 9 of slot 1 upwards. D-channels are not affected by licensing. The license is available in 2, 8 and 22 channel variants which can be combined for the total number of channels required.

- **SIP Trunk Channels**

These licenses are used to configure the maximum number of simultaneous SIP trunk calls supported. The licenses are consumed by calls in progress on a SIP channel. For SIP support the system also requires [VCM resources](#)<sup>215</sup>. The license is available in 1, 5, 10 and 20 channel variants which can be combined for the total number of channels required.

- **IP500 Voice Networking**

These licenses enable support for SCN, QSIG and H323 IP trunks. For voice networking support, the system also requires [VCM resources](#)<sup>215</sup>.

- **SM Trunk Channels**

These licenses are used to enabled SM lines for connection to an Avaya Aura network. The IP Office system also requires a **Branch System** license.

## 12.13.4 Telephone/Endpoint Licenses

The use of H323 and SIP phones with IP Office is controlled by the following licenses. Different licenses are used for Avaya IP phones and non-Avaya phones including non-Avaya soft phones.

For IP soft phones, the license requirements vary depending on the particular application and are not covered here. Refer to the specific documentation for the application. However, most Avaya soft phone applications do not require an Avaya IP Endpoint license.

By default, the endpoint licenses are consumed by each IP phone that registers with the system in the order that the phones register. However, it is possible to reserve a license for a particular extension in order to ensure that that phone always obtains a license first if available. This is done through the **Reserve Licence** setting of the extension's settings in the system configuration. Licenses are released if the phone unregisters unless reserved.

-  **Warning**

Avaya IP phones without a license are still able to register but are limited to making emergency calls only (**Dial Emergency** short code calls). The associated user is treated as if logged off and the phone may display "*No license available*" and "*Emergency Calls Only*". If a license becomes available, it is assigned to any unlicensed DECT handsets first and then to any other unlicensed Avaya IP phone in the order that the phones registered.

- **Avaya IP Endpoints License**

These licenses are used to license additional physical Avaya IP phones. This includes all 1600, 9600, DECT R4, Spectralink and VPN phones supported.

- **3rd Party IP Endpoints License**

These licenses are used for support of non-Avaya IP phones including SIP extensions. The available license are used in order of phone registration. If no licenses are available the phone is not able to register. This license was previously called the **IP End-points** license.





- **Avaya Softphone License**

This license is used to allow support for [Avaya Workplace Client](#)<sup>244</sup> by a user whose licensed profile does not normally support those applications as part of the profile license.

## 12.13.5 User Licenses

The features available to a basic user can be enhanced by the addition of user licenses. Once these licenses are present in the system configuration, the corresponding profiles can be applied to selected users through their **User | Profile** setting in the system configuration.

Note that for all profiles other than **Basic User**, a **Preferred Edition** system license is a pre-requisite for the required user licenses.

	 <b>Basic User</b>	 <b>Office Worker</b>	 <b>Teleworker</b>	 <b>Mobile Worker</b>	 <b>Power User</b>
<b>one-X Portal Services</b>	-	✓	✓	-	✓
<b>" Telecommuter options</b>	-	-	✓	-	✓
<b>UMS Web Services</b>	-	✓	✓	-	✓
<b>Mobility Features</b>	-	-	-	✓	✓
<b>TTS for Email Reading</b> <sup>[4]</sup>	-	-	-	✓	✓
<b>Remote Worker</b> <sup>[2]</sup>	-	-	✓	-	✓
<b>Avaya Workplace Client</b>	✓ <sup>[5]</sup>	✓	✓	✓ <sup>[5]</sup>	✓
<b>" Conference Scheduling</b>	-	-	-	-	✓

1. A [Preferred Edition](#) <sup>[269]</sup> system license is a pre-requisite for any user profile license other than **Basic User**.
  - In a Small Community Network, the **Preferred Edition** license of the central system is automatically shared with other systems in the network, enabling user profile licenses on those other systems. However, each system supporting a Voicemail Pro server, for example for distributed voicemail, still requires its own **Preferred Edition** license.
2. Release 8.0 supports users using remote H323 extensions. Up to 4 Basic users are supported on remote extensions on system. Additional remote users are supported if licensed and configured for either a **Teleworker** or **Power User** user profile.
3. Require that the one-X Portal for IP Office and Voicemail Pro applications are also installed for advanced features.
4. TTS for Email Reading also requires the voicemail system to be licensed for the number of simultaneous TTS session required.
5. Supported for [Avaya Workplace Client](#) <sup>[244]</sup> standalone mode using a Avaya Softphone License.

### User Licenses

- **Teleworker License**  
These licenses set the number of users who can have their profile set as **Teleworker**. For user with this optional, additional settings are enabled in the configuration for the following services: one-X Portal for IP Office with Telecommuter option and UMS Web Services. A **Preferred Edition** [system license](#) <sup>[269]</sup> is a pre-requisite for this license.
- **Mobile Worker License**  
These licenses set the number of users who can have their profile set as **Mobile Worker**. For user with this optional, additional settings are enabled in the configuration for the following services: Mobility Features and TTS for Email Reading. For IP Office Release 8.0 and higher, all mobility features are enabled for all users by the **Essential Edition** license. A **Preferred Edition** [system license](#) <sup>[269]</sup> is a pre-requisite for this license.
- **Office Worker License**  
These licenses set the number of users who can have their profile set as **Office Worker**. For user with this optional, additional settings are enabled in the configuration for the following services: one-X Portal for IP Office (no telecommuter features) and UMS Web Services. A **Preferred Edition** [system license](#) <sup>[269]</sup> is a pre-requisite for this license.
- **Power User Profile License**  
These licenses set the number of users who can have their profile set as **Power User**. For user with this optional, the same additional services as for **Teleworker** and **Mobile Worker** are enabled for the user. A **Preferred Edition** [system license](#) <sup>[269]</sup> is a pre-requisite for this license.

### Other User Licenses

In addition to the user profile licenses above, the following individual user licenses are available:

- **Receptionist:**

This license is used to enable support for the IP Office SoftConsole application. This license can only be used by users set to **Receptionist** in the IP Office configuration. A maximum of 4 receptionist are supported. This license was previously called **SoftConsole**. An instance of this license is consumed by each user configured as a **Receptionist**.

---

## 12.13.6 Voicemail Pro Licenses

Voicemail Pro is enable by the addition of the following licenses.

- **Preferred Edition (Voicemail Pro) :**

This license enables support for Voicemail Pro as the IP Office's voicemail server with 4 voicemail ports. The **Preferred Edition** license allows the voicemail server to provide the services listed below. For IP Office Release 8.0 and higher, an **Essential Edition** license is a pre-requisite for this license on IP500 V2 systems.

- Mailboxes for all users and hunt groups.
- Announcements for users and hunt groups.
- Customizable call flows.
- Call recording to mailboxes.
- Campaigns.
- TTS email reading for users licensed to **Mobile Worker** or **Power User** profiles. Also requires TTS licenses.
- Use of **Conference Meet Me** functions.
- Database access

1. A **Preferred Edition** <sup>289</sup> system license is a pre-requisite for any user profile license other than **Basic User**.

- In a Small Community Network, the **Preferred Edition** license of the central system is automatically shared with other systems in the network, enabling user profile licenses on those other systems. However, each system supporting a Voicemail Pro server, for example for distributed voicemail, still requires its own **Preferred Edition** license.

- **Preferred Edition Additional Voicemail Ports**

The required license for Voicemail Pro server support (Preferred Edition (Voicemail Pro)) also enables 4 voicemail ports. These licenses can be used to add additional voicemail ports up to the maximum capacity of the IP Office system (IP500 V2 = 40). This license was previously called **Additional Voicemail Pro (ports)**. These licenses are available in 2, 4, 8 and 16 port variants which can be combined for the total number of ports required.

- **Media Manager**

Allows the use of Media Manager on an IP Office Application Server to provide long term archiving of call recordings. In a Small Community Network, each IP Offices requires its own license.

- **VMPro Networked Messaging**

Enables VPNM (Voicemail Pro Networked Messaging) functionality within Voicemail Pro. This allows message exchange with remote Voicemail Pro systems and Avaya Interchange systems.

- **VMPro TTS (Generic)**

This legacy license enables the use of text to speech facilities using third party TTS software with Voicemail Pro on a Windows server. One license per simultaneous instance of TTS usage. Note that the IP Office Advance Edition license also enables 8 ports of generic TTS but useable with Speak Text actions only.

- **VMPro TTS (ScanSoft)**

This legacy license enables the use of text to speech facilities using Avaya supplied TTS software with Voicemail Pro on a Windows server. One license per simultaneous instance of TTS usage.

- **VMPro TTS Professional**

This license enables the use of text to speech facilities provided by Voicemail Pro on a Linux based server. One license per simultaneous instance of TTS usage.

- **UMS Web Services**

These licenses are used to enable UMS voicemail services support for users set to the **Basic User** profile. Other users are enabled for UMS through their licensed user profile. These licenses are also used to license hunt groups for UMS voicemail services. Each license enables 1 user.

### 12.13.7 Trial Licenses

Trial licenses can be requested. Each is valid for 60 days from the date of issue and can only be issued once for a particular System SD card serial number. Apart from that restriction, the trial licenses work the same as full licenses.

### 12.13.8 CTI Licenses

- **CTI Link Pro :**  
Enables CTI Link Pro functionality (TAPI Link Pro and DEVLink Pro).
- **Wave User :**  
Allows streaming of WAV files, using TAPILink Pro, for 3rd party voice applications. This is a per user license. Note that TAPI WAV calls use system data channels taken from the same pools as used for voicemail ports. The maximum number of simultaneous TAPI WAV user calls and voicemail users is determined by the IP Office control unit type; IP500 V2 =40.

### 12.13.9 Other Licenses

- **Audix Voicemail :**  
Enables IP Office to use a remote Intuity Audix or Modular Messaging system for voicemail rather than requiring a local voicemail server.
- **IPSec Tunneling :**  
Enables the IP Office to initiate and terminate IPSec and L2TP tunnels.
- **Avaya Contact Center Select**  
This license is required for the support of Avaya Contact Center Select.

---

## 12.14 Hardware/Software Compatibility

This page summarizes the hardware and software components supported on different releases of IP Office core software. Additional information for other Avaya products including compatible software versions, can be obtained from the [Avaya Product Compatibility Matrix](https://secureservices.avaya.com/compatibility-matrix/menus/product.xhtml) website (<https://secureservices.avaya.com/compatibility-matrix/menus/product.xhtml>).

- [Controls Units](#) <sup>277</sup>
- [External Expansion Modules](#) <sup>277</sup>
- [Base and Trunk Cards](#) <sup>278</sup>
- [Phones](#) <sup>280</sup>
- [Applications](#) <sup>284</sup>

## 12.14.1 Control Units and Control Unit Components

Except where stated otherwise, support assumes the latest available service pack.

### Control Units

Control Unit	Material Code	8.0	8.1	9.0	9.1	10.0	10.1	11.0	11.1	12.0
IP500	700417207	✓	✓	✓	-	-	-	-	-	-
IP500 V2	700476005	✓	✓	✓	✓	✓	✓	✓	✓	✓
IP500 V2A	700514867	-	-	-	-	-	-	✓ <sup>[1]</sup>	✓	✓

1. Supported for R11.0.4.8 and higher.

### External Expansion Modules

Module	Material Code	8.0	8.1	9.0	9.1	10.0	10.1	11.0	11.1	12.0
IP400 ATM16 <sup>[3]</sup>	700211360	✓	✓	✓	✓	✓	✓	✓	✓	✓
IP400 DS16	700184807	✓	✓	✓	-	-	-	-	-	-
IP400 DS30	700184880	✓	✓	✓	-	-	-	-	-	-
IP400 DS16 V2 <sup>[3]</sup>	700359839	✓	✓	✓	✓	✓	✓	✓	✓	✓
IP400 DS30 V2 <sup>[3]</sup>	700359847	✓	✓	✓	✓	✓	✓	✓	✓	✓
IP400 Phone 8	700184773	✓	✓	✓	-	-	-	-	-	-
IP400 Phone 16	700184781	✓	✓	✓	-	-	-	-	-	-
IP400 Phone 30	700184799	✓	✓	✓	-	-	-	-	-	-
IP400 Phone 8 V2	700359896	✓	✓	✓	-	-	-	-	-	-
IP400 Phone 16 V2 <sup>[3]</sup>	700359904	✓	✓	✓	✓	✓	✓	✓	✓	✓
IP400 Phone 30 V2 <sup>[3]</sup>	700359912	✓	✓	✓	✓	✓	✓	✓	✓	✓
IP400 So8	700185077	-	-	-	-	-	-	-	-	-
IP400 WAN3 <sup>[1]</sup>	-	-	-	-	-	-	-	-	-	-
IP400 WAN3 10/100 <sup>[1]</sup>	700262009	-	-	-	-	-	-	-	-	-
IP500 ATM16 <sup>[2]</sup>	700449473	✓	✓	✓	✓	✓	✓	✓	✓	✓
IP500 So8	700449515	✓	✓	✓	-	-	-	-	-	-
IP500 DS16	700449499	✓	✓	✓	✓	✓	✓	-	-	-
IP500 DS30	700426216	✓	✓	✓	✓	✓	✓	-	-	-
IP500 DS16A (RJ21) <sup>[6]</sup>	700500699	✓	✓	✓	✓	✓	✓	✓	✓	✓
IP500 DS30A (RJ21) <sup>[6]</sup>	700500698	✓	✓	✓	✓	✓	✓	✓	✓	✓
IP500 DS16B	700501585	-	✓ <sup>[5]</sup>	✓	✓	✓	✓	✓	✓	✓
IP500 DS30B	700501586	-	✓ <sup>[5]</sup>	✓	✓	✓	✓	✓	✓	✓
IP500 DS16B2	700511093	-	-	-	✓ <sup>[4]</sup>	✓ <sup>[4]</sup>	✓	✓	✓	✓
IP500 DS30B2	700511094	-	-	-	✓ <sup>[4]</sup>	✓ <sup>[4]</sup>	✓	✓	✓	✓
IP500 Phone 16	700449507	✓	✓	✓	✓	✓	✓	✓	✓	✓
IP500 Phone 30	700426224	✓	✓	✓	✓	✓	✓	✓	✓	✓

1. Not supported on IP500 V2 systems.
2. North America only, unless accepted in targeted country.
3. These IP400 variants are still supported on IP Office R9.1 and higher.
4. Originally only supported in R10.1. Further support added in R9.1 SP12 and R10.0 SP5.
5. Service Pack 9 and higher.
6. Not supported for IP Office Subscription mode systems.

## Base and Cards

Base Cards	Material Code	8.0	8.1	9.0	9.1	10.0	10.1	11.0	11.1	12.0
IP500 Phone 2	700431778	✓	✓	✓	✓	✓	✓	✓	✓	✓
IP500 Phone 8	700417231	✓	✓	✓	✓	✓	✓	✓	✓	✓
IP500 Digital Station 8 <sup>[9]</sup>	700417330	✓	✓	✓	✓	✓	✓	✓	✓	✓
IP500 Digital Station 8A <sup>[8]</sup>	700514857	-	-	-	-	-	-	✓	✓	✓
IP500 Card Carrier <sup>[6]</sup>	700417215	✓	✓	✓	-	-	-	-	-	-
IP500 VCM 32 <sup>[6]</sup>	700417389	✓	✓	✓	✓	✓	✓	✓	-	-
IP500 VCM 64 <sup>[6]</sup>	700417397	✓	✓	✓	✓	✓	✓	✓	-	-
IP500 VCM 32 V2 <sup>[6]</sup>	700504031	-	✓	✓	✓	✓	✓	✓	✓	✓
IP500 VCM 64 V2 <sup>[6]</sup>	700504032	-	✓	✓	✓	✓	✓	✓	✓	✓
IP500 VCM 32 V3 <sup>[11]</sup>	700517168	-	-	-	-	-	-	-	✓	✓
IP500 VCM 64 V3 <sup>[11]</sup>	700517169	-	-	-	-	-	-	-	✓	✓
IP500 4-Port Expansion <sup>[6]</sup>	700472889	✓	✓	✓	✓	✓	✓	✓	✓	✓
IP500 ETR6 <sup>[1][2][7]</sup>	700476039	✓	✓	✓	✓	✓	✓	✓	-	-
IP500 ATM4 Combo Card <sup>[1]</sup>	700476013	✓	✓	✓	✓	✓	✓	✓	-	-
" <b>PCS04</b> <sup>[285]</sup> and higher <sup>[5]</sup>	700476013	✓	✓	✓	✓	✓	✓	✓	-	-
IP500 ATM4 Combo Card V2 <sup>[1]</sup>	700504556	-	✓	✓	✓	✓	✓	✓	✓	✓
IP500 BRI Combo Card BRI <sup>[1]</sup>	700476021	✓	✓	✓	✓	✓	✓	✓	✓	✓
IP500 TCM 8 <sup>[1][7]</sup>	700500758	✓	✓	✓	✓	✓	✓	✓	✓	✓
Unified Communications Module v1 <sup>[1][6]</sup>	700501442	✓	✓	✓	✓	✓	✓	✓	✓	-
Unified Communications Module v2 <sup>[1][6]</sup>	700507449	-	-	-	✓	✓	✓	✓	✓	✓

Trunk Cards	Material Code	8.0	8.1	9.0	9.1	10.0	10.1	11.0	11.1	12.0
IP500 Alog Trunk Card	700417405	✓	✓	✓	✓	✓	✓	✓	-	-
" <b>PCS10</b> <sup>[285]</sup> and higher <sup>[4]</sup>	700417405	✓	✓	✓	✓	✓	✓	✓	-	-
IP500 Alog Trunk Card V2 <sup>[1][3]</sup>	700503164	-	✓	✓	✓	✓	✓	✓	✓	✓
IP500 BRI 4 Trunk Card	700417413	✓	✓	✓	✓	✓	✓	✓	✓	✓
IP500 BRI 8 Trunk Card	700417421	✓	✓	✓	✓	✓	✓	✓	✓	✓
IP500 PRI-1U	700417439	✓	✓	✓	✓	✓	✓	✓	✓	✓
IP500 PRI-2U	700417462	✓	✓	✓	✓	✓	✓	✓	✓	✓
IP500 PRI-1U V2 <sup>[10]</sup>	700515485	-	-	-	-	-	-	-	✓	✓
IP500 PRI-2U V2 <sup>[10]</sup>	700515486	-	-	-	-	-	-	-	✓	✓
IP500 T1(J) PRI Dual	700509377	-	-	-	✓	✓	✓	✓	✓	✓

1. IP500 V2 systems only.
2. Only supported in IP Office Basic Edition - PARTNER Mode or IP Office Basic Edition (U-Law) modes running in a North American locale.
3. Supported for 8.1 Feature Pack 1 and higher.
4. These cards are support by IP Office Release 4.0 and higher. However, PCS10 and higher cards are only supported in systems running IP Office Release 6.1(20), 7.0(12) or 8.0 and higher. Refer to IP Office Technical Tip 237.
5. These cards are supported by IP Office Release 6.0 and higher. However, PCS04 and higher cards are only supported in systems running IP Office Release 6.1(20), 7.0(12) or 8.0 and higher. Refer to IP Office Technical Tip 237.
6. Not supported for IP Office Basic Edition mode systems.
7. Not supported for IP Office Subscription mode systems.
8. **DS8A**: Supported for R11.0.4.8 and higher.
9. **DS8**: Not supported in IP500 V2A control units.

10. **PRI-U V2:** Functional the same as previous PRI-U trunk cards. However, only supported from R11.1 FP2 SP4.
11. **VCM 32/64 V3:** Supported for R11.1.3 and higher.

## 12.14.2 Phones

- [1100 Series](#)<sup>[280]</sup> • [3700 Series](#)<sup>[280]</sup> • [5600 Series](#)<sup>[281]</sup> • [E100 Series](#)<sup>[282]</sup> • [T-Series](#)<sup>[283]</sup>
- [1200 Series](#)<sup>[280]</sup> • [3800 Series](#)<sup>[281]</sup> • [7400 Series](#)<sup>[281]</sup> • [H100 Series](#)<sup>[282]</sup> • [T3 Series](#)<sup>[283]</sup>
- [1400 Series](#)<sup>[280]</sup> • [3900 Series](#)<sup>[281]</sup> • [9500 Series](#)<sup>[281]</sup> • [H200 Series](#)<sup>[282]</sup> • [T3 IP Series](#)<sup>[283]</sup>
- [1600 Series](#)<sup>[280]</sup> • [4400 Series](#)<sup>[281]</sup> • [9600 Series](#)<sup>[281]</sup> • [J100 Series](#)<sup>[282]</sup>
- [2400 Series](#)<sup>[280]</sup> • [4600 Series](#)<sup>[281]</sup> • [B100 Series](#)<sup>[282]</sup> • [K100 Series](#)<sup>[283]</sup>
- [3600 Series](#)<sup>[280]</sup> • [5400 Series](#)<sup>[281]</sup> • [D100 Series](#)<sup>[282]</sup> • [M-Series](#)<sup>[283]</sup>

### 1100/1200 Series

Phone	8.0	8.1	9.0	9.1	10.0	10.1	11.0	11.1	12.0
1120E	✓	✓	✓	✓	✓	✓	✓	✓	✓
1140E	✓	✓	✓	✓	✓	✓	✓	✓	✓
1220	✓	✓	✓	✓	✓	✓	✓	✓	✓
1230	✓	✓	✓	✓	✓	✓	✓	✓	✓

### 1400 Series

Phone	8.0	8.1	9.0	9.1	10.0	10.1	11.0	11.1	12.0
1403	✓	✓	✓	✓	✓	✓	✓	✓	✓
1408	✓	✓	✓	✓	✓	✓	✓	✓	✓
1416	✓	✓	✓	✓	✓	✓	✓	✓	✓

### 1600 Series

Phone	8.0	8.1	9.0	9.1	10.0	10.1	11.0	11.1	12.0
1603 <sup>[1]</sup>	✓	✓	✓	✓	✓	✓	✓	✓	✓
1603-I	✓	✓	✓	✓	✓	✓	✓	✓	✓
1603SW	✓	✓	✓	✓	✓	✓	✓	✓	✓
1603SW-I	✓	✓	✓	✓	✓	✓	✓	✓	✓
1608 <sup>[1]</sup>	✓	✓	✓	✓	✓	✓	✓	✓	✓
1608-I	✓	✓	✓	✓	✓	✓	✓	✓	✓
1616 <sup>[1]</sup>	✓	✓	✓	✓	✓	✓	✓	✓	✓
1616-I	✓	✓	✓	✓	✓	✓	✓	✓	✓

1. 4.2 Q4 '08+.

### 2400 Series

Phone	8.0	8.1	9.0	9.1	10.0	10.1	11.0	11.1	12.0
2402D	✓	✓	✓	✓	✓	✓	✓	✓	✓
2410D	✓	✓	✓	✓	✓	✓	✓	✓	✓
2420	✓	✓	✓	✓	✓	✓	✓	✓	✓

### 3600 Series

The 3600 Series of phones is no longer supported by Avaya.

### 3700 Series

Phone	8.0	8.1	9.0	9.1	10.0	10.1	11.0	11.1	12.0
3701	✓	✓	✓	✓	✓	✓	-	-	-
3711	✓	✓	✓	✓	✓	✓	-	-	-
3720	✓	✓	✓	✓	✓	✓	✓	✓	✓
3725	✓	✓	✓	✓	✓	✓	✓	✓	✓
3730 <sup>[1]</sup>	-	-	-	✓	✓	✓	✓	✓	✓
3735 <sup>[1]</sup>	-	-	-	✓	✓	✓	✓	✓	✓
3740	✓	✓	✓	✓	✓	✓	✓	-	-
3745	-	-	-	-	✓	✓	✓	✓	✓
3749	✓	✓	✓	✓	✓	✓	✓	✓	✓
3755 <sup>[2]</sup>	-	-	-	-	-	-	-	✓	✓

Phone	8.0	8.1	9.0	9.1	10.0	10.1	11.0	11.1	12.0
3759 <sup>[2]</sup>	-	-	-	-	-	-	-	✓	✓

1. Supported from R9.1 SP11, R10.0 SP4.
2. Supported from R11.1.3 SP1.

### 3800/3900 Series

Phone	8.0	8.1	9.0	9.1	10.0	10.1	11.0	11.1	12.0
3810	✓	✓	✓	✓	✓	-	-	-	-
3910	✓	✓	✓	✓	✓	-	-	-	-
3920	✓	✓	✓	✓	✓	-	-	-	-

### 4400 Series

Phone	8.0	8.1	9.0	9.1	10.0	10.1	11.0	11.1	12.0
4406D	✓	✓	✓	✓	-	-	-	-	-
4412D	✓	✓	✓	✓	-	-	-	-	-
4424D	✓	✓	✓	✓	-	-	-	-	-

### 4600 Series

Phone	8.0	8.1	9.0	9.1	10.0	10.1	11.0	11.1	12.0
4601	✓	✓	✓	✓	-	-	-	-	-
4602IP	✓	✓	✓	✓	-	-	-	-	-
4602SW	✓	✓	✓	✓	-	-	-	-	-
4606	-	-	-	-	-	-	-	-	-
4610SW	✓	✓	✓	✓	-	-	-	-	-
4612	-	-	-	-	-	-	-	-	-
4620	✓	✓	✓	✓	-	-	-	-	-
4621	✓	✓	✓	✓	-	-	-	-	-
4624	-	-	-	-	-	-	-	-	-
4625	✓	✓	✓	✓	-	-	-	-	-

### 5400 Series

Phone	8.0	8.1	9.0	9.1	10.0	10.1	11.0	11.1	12.0
5402	✓	✓	✓	✓	-	-	-	-	-
5410	✓	✓	✓	✓	-	-	-	-	-
5420	✓	✓	✓	✓	-	-	-	-	-

### 5600 Series

Phone	8.0	8.1	9.0	9.1	10.0	10.1	11.0	11.1	12.0
5601	✓	✓	✓	✓	-	-	-	-	-
5602IP	✓	✓	✓	✓	-	-	-	-	-
5602SW	✓	✓	✓	✓	-	-	-	-	-
5610SW	✓	✓	✓	✓	-	-	-	-	-
5620	✓	✓	✓	✓	-	-	-	-	-
5621	✓	✓	✓	✓	-	-	-	-	-

### 7400 Series

This series of phones are no longer supported by Avaya.

### 9500 Series

Phone	8.0	8.1	9.0	9.1	10.0	10.1	11.0	11.1	12.0
9504	✓	✓	✓	✓	✓	✓	✓	✓	✓
9508	✓	✓	✓	✓	✓	✓	✓	✓	✓

### 9600 Series

Phone	8.0	8.1	9.0	9.1	10.0	10.1	11.0	11.1	12.0
9608	✓	✓	✓	✓	✓	✓	✓	✓	✓

Phone	8.0	8.1	9.0	9.1	10.0	10.1	11.0	11.1	12.0
9608G	✓	✓	✓	✓	✓	✓	✓	✓	✓
9611	✓	✓	✓	✓	✓	✓	✓	✓	✓
9620 <sup>[2]</sup>	✓	✓	✓	✓	✓	✓	✓	-	-
9620L <sup>[2]</sup>	✓	✓	✓	✓	✓	✓	✓	-	-
9620C <sup>[2]</sup>	✓	✓	✓	✓	✓	✓	✓	-	-
9621G	✓	✓	✓	✓	✓	✓	✓	✓	✓
9621GS	✓	✓	✓	✓	✓	✓	✓	✓	✓
9630 <sup>[2]</sup>	✓	✓	✓	✓	✓	✓	✓	-	-
9630G <sup>[2]</sup>	✓	✓	✓	✓	✓	✓	✓	-	-
9640 <sup>[2]</sup>	✓	✓	✓	✓	✓	✓	✓	-	-
9640G <sup>[2]</sup>	✓	✓	✓	✓	✓	✓	✓	-	-
9641G	✓	✓	✓	✓	✓	✓	✓	✓	✓
9641GS	✓	✓	✓	✓	✓	✓	✓	✓	✓
9650 <sup>[2]</sup>	✓	✓	✓	✓	✓	✓	✓	-	-
9650C <sup>[2]</sup>	✓	✓	✓	✓	✓	✓	✓	-	-

1. Release 8.0 2012 Q1 service pack and higher.
2. These models are no longer supported by Avaya.

### B100 Series

Phone	8.0	8.1	9.0	9.1	10.0	10.1	11.0	11.1	12.0
B149 (analog)	✓	✓	✓	✓	✓	✓	✓	✓	✓
B159 (analog)	✓	✓	✓	✓	✓	✓	✓	✓	✓
B169 (DECT via analog or SIP base station)	✓	✓	✓	✓	✓	✓	✓	✓	✓
B179 (SIP)	✓	✓	✓	✓	✓	✓	✓	✓	✓
B199 (SIP)	-	-	-	-	-	✓	✓	✓	✓

### D100 Series

Phone	8.0	8.1	9.0	9.1	10.0	10.1	11.0	11.1	12.0
D160	-	✓ <sup>[1]</sup>	✓	✓	✓	✓	✓	✓	✓

1. Supported for 8.1 Feature Pack 1 and higher.

### E100 Series

Phone	8.0	8.1	9.0	9.1	10.0	10.1	11.0	11.1	12.0
E129	-	-	✓	✓	✓	✓	✓	-	-
E159	-	-	✓	✓	✓	✓	✓	-	-
E169	-	-	✓	✓	✓	✓	✓	-	-

The E159 and E169 phones are no longer supported by Avaya.

### H100 Series

Phone	8.0	8.1	9.0	9.1	10.0	10.1	11.0	11.1	12.0
H175	-	-	-	-	✓	✓	✓	✓	✓

### H200 Series

Phone	8.0	8.1	9.0	9.1	10.0	10.1	11.0	11.1	12.0
H229	-	-	-	-	-	-	✓	✓	✓
H239	-	-	-	-	-	-	✓	✓	✓
H249	-	-	-	-	-	-	✓	✓	✓

1. Supported from R11.0 SP1.

### J100 Series

NB: Support does not include 3PCC Open SIP variants of these phones.

Phone	8.0	8.1	9.0	9.1	10.0	10.1	11.0	11.1	12.0
J129 <sup>[1]</sup>	-	-	-	-	✓	✓	✓	✓	✓

Phone	8.0	8.1	9.0	9.1	10.0	10.1	11.0	11.1	12.0
J139 <sup>[3]</sup>	-	-	-	-	-	-	✓	✓	✓
J159 <sup>[4]</sup>	-	-	-	-	-	-	✓	✓	✓
J169 <sup>[2]</sup>	-	-	-	-	-	-	✓	✓	✓
J179 <sup>[2]</sup>	-	-	-	-	-	-	✓	✓	✓
J189 <sup>[5]</sup>	-	-	-	-	-	-	-	✓	✓

1. Supported from R10.0 SP2.
2. Supported on earlier releases using H323 firmware. Refer to the "[IP Office SIP Extension Installation Notes](#)".
3. Supported from R11.0 SP1.
4. Supported from R11.0.4.2.
5. Supported from R11.1 FP1.

### K100 Series (Vantage Phones)

Phone	8.0	8.1	9.0	9.1	10.0	10.1	11.0	11.1	12.0
K155 V1	-	-	-	-	-	-	✓ <sup>[1]</sup>	✓	✓
K155 V2	-	-	-	-	-	-	-	✓	✓
K165 V1/V2	-	-	-	-	-	-	✓	✓	✓
K175 V1/V2	-	-	-	-	-	-	✓	✓	✓
K175 V3	-	-	-	-	-	-	-	✓	✓

1. Supported from R11.0 SP1.

### M-Series

Phone	8.0	8.1	9.0	9.1	10.0	10.1	11.0	11.1	12.0
M7100	✓	✓	✓	✓	✓	✓	✓	✓	✓
M7100N	✓	✓	✓	✓	✓	✓	✓	✓	✓
M7208	✓	✓	✓	✓	✓	✓	✓	✓	✓
M7208N	✓	✓	✓	✓	✓	✓	✓	✓	✓
M7310	✓	✓	✓	✓	✓	✓	✓	✓	✓
M7310N	✓	✓	✓	✓	✓	✓	✓	✓	✓
M7324	✓	✓	✓	✓	✓	✓	✓	✓	✓
M7324N	✓	✓	✓	✓	✓	✓	✓	✓	✓

### T-Series

Phone	8.0	8.1	9.0	9.1	10.0	10.1	11.0	11.1	12.0
T7000	✓	✓	✓	✓	✓	✓	✓	✓	✓
T7100	✓	✓	✓	✓	✓	✓	✓	✓	✓
T7208	✓	✓	✓	✓	✓	✓	✓	✓	✓
T7316	✓	✓	✓	✓	✓	✓	✓	✓	✓
T7316E	✓	✓	✓	✓	✓	✓	✓	✓	✓
T7406	✓	✓	✓	✓	✓	✓	✓	✓	✓
T7406E	✓	✓	✓	✓	✓	✓	✓	✓	✓
ACU	✓	✓	✓	✓	✓	✓	✓	✓	✓

### T3/T3IP Series

Phone	8.0	8.1	9.0	9.1	10.0	10.1	11.0	11.1	12.0
T3 Compact	✓	✓	✓	✓	✓	✓	-	-	-
T3 Classic	✓	✓	✓	✓	✓	✓	-	-	-
T3 Comfort	✓	✓	✓	✓	✓	✓	-	-	-
T3 IP Compact	✓	✓	✓	✓	✓	✓	-	-	-
T3 IP Classic	✓	✓	✓	✓	✓	✓	-	-	-
T3 IP Comfort	✓	✓	✓	✓	✓	✓	-	-	-

### 12.14.3 Applications

This table simply indicates which applications are supported for IP500 V2 systems. Additional requirements may apply depending on the mode in which the system is operating.

Application	8.0	8.1	9.0	9.1	10.0	10.1	11.0	11.1				12.0
								-	FP1	FP2	FP3	
Contact Recorder	-	✓	✓	✓	✓	✓	-	-	-	-	-	-
ContactStore	✓	✓	✓	✓	-	-	-	-	-	-	-	-
Customer Call Reporter	✓	✓	✓	-	-	-	-	-	-	-	-	-
Data Migration Manager	✓	✓	✓	-	-	-	-	-	-	-	-	-
Avaya Communicator for Windows	-	✓	✓	✓	✓	✓	✓	✓	✓	-	-	-
Avaya Communicator for iPad	-	✓	✓	✓	✓	✓	✓	✓	✓	-	-	-
Avaya Communicator for Web	-	-	-	✓	✓	✓	✓	✓	✓	-	-	-
Avaya Workplace Client	-	-	-	-	-	-	✓	✓	✓	✓	✓	✓
IP Office Contact Center	-	-	✓	✓	✓	✓	✓	✓ <sup>[1]</sup>	-	-	-	-
Integrated Contact Reporter	-	-	-	-	-	✓	-	-	-	-	-	-
Manager	✓	✓	✓	✓	✓	✓	✓	✓	✓	✓	✓	✓
Media Manager (local)	-	-	-	-	-	✓	✓	✓	✓	✓	✓	✓
" (Centralized)	-	-	-	-	-	-	-	-	-	✓	✓	✓
MS Teams Calling	-	-	-	-	-	-	-	-	-	✓	✓	✓
Phone Manager	✓	✓	-	-	-	-	-	-	-	-	-	-
" Pro	✓	✓	-	-	-	-	-	-	-	-	-	-
" Pro Softphone	✓	✓	-	-	-	-	-	-	-	-	-	-
one-X Mobile	✓	✓	✓	✓	✓	✓	✓	✓	✓	-	-	-
one-X Mobile Preferred	✓	✓	✓	✓	✓	✓	✓	✓	✓	-	-	-
one-X Portal	✓	✓	✓	✓	✓	✓	✓	✓	✓	✓	✓	✓
" Call Assistant	✓	✓	✓	✓	✓	✓	✓	✓	✓	✓	✓	✓
" Lync plug-in	-	✓	✓	✓	✓	✓	✓	✓	✓	✓	✓	-
" Outlook plug-in	✓	✓	✓	✓	✓	✓	✓	✓	✓	✓	✓	✓
" Salesforce plug-in	✓	✓	✓	✓	-	-	-	-	-	-	-	-
IP Office Web Client	-	-	-	-	-	-	✓	✓	✓	✓	✓	✓
Outbound Call Express	-	✓	✓	✓	-	-	-	-	-	-	-	-
Self-Administration	-	-	-	✓	✓	✓	✓	✓	✓	-	-	-
SoftConsole	✓	✓	✓	✓	✓	✓	✓	✓	✓	✓	✓	✓
System Status Application	✓	✓	✓	✓	✓	✓	✓	✓	✓	✓	✓	✓
System Monitor	✓	✓	✓	✓	✓	✓	✓	✓	✓	✓	✓	✓
TAPI Lite (1st-Party)	✓	✓	✓	✓	✓	✓	✓	✓	✓	✓	✓	✓
TAPI Pro (3rd-Party)	✓	✓	✓	✓	✓	✓	✓	✓	✓	✓	✓	✓
User Portal	-	-	-	-	-	-	-	-	-	✓	✓	✓
Integrated Messaging	✓	✓	✓	✓	✓	✓	✓	✓	✓	✓	✓	✓
Video Softphone (Mac)	✓	✓	✓	✓	✓	✓	-	-	-	-	-	-
" (Windows)	✓	✓	✓	✓	-	-	-	-	-	-	-	-
Voicemail Pro	✓	✓	✓	✓	✓	✓	✓	✓	✓	✓	✓	✓
Web Collaboration	-	-	-	✓	✓	✓	✓	✓	✓	✓	✓	-

## 12.15 PCS Levels

Each item of IP Office hardware has a Product Change Status (PCS) level. This is usually included on the label on the hardware prefix with **PCS**.

The PCS level is increased each time a significant change is made to the components of that piece of hardware. For example the PCS level may be increased when a component is replaced by one from a different supplier.

Normally changes to a PCS level are not important and items of the same hardware but with different PCS levels are still identical in operation and can be interchanged. However, there are some exceptions as listed below.

### PCS Level Restrictions

- **IP500 Analog Trunk Card V1**

These cards are supported by IP Office Release 4.0 and higher. However, PCS10 and higher cards are only supported in systems running IP Office Release 6.1(20), 7.0(12) or 8.0 and higher. Refer to IP Office Technical Tip 237.

- **IP500 ATM4 Combination Card V1**

These cards are supported by IP Office Release 6.0 and higher. However, PCS04 and higher cards are only supported in systems running IP Office Release 6.1(20), 7.0(12) or 8.0 and higher. Refer to IP Office Technical Tip 237.

- **IP500 V2 Control Unit**

To support IP Office Release 9.1 or higher, PCS 14 or lower units must first install Release 8.1(65) (or higher 8.1) or any Release 9.0 and then upgrade to Release 9.1 or higher. Care should be taken to ensure that no calls are made before the final upgrade, otherwise the system will require upgrade license.

## 12.16 TAA

Those items labeled as TAA are compliant with the requirements of the Trade Agreements Act which is a prerequisite for federal purchases in the United States of America. Unless otherwise stated, the TAA variants of equipment are physically and functionally the same as the non-TAA variants.

		SAP Code
<b>Control Unit</b>	<a href="#">IPO IP500 V2A CNTRL UNIT TAA</a> <sup>203</sup>	700514869
	<a href="#">IPO IP500 V2 CNTRL UNIT TAA</a> <sup>203</sup>	700501510
<b>Base Cards</b>	<a href="#">IPO IP500 EXTN CARD DGTL STA 8A TAA</a> <sup>213</sup>	700514868
	<a href="#">IPO IP500 EXTN CARD DGTL STA 8 TAA</a> <sup>213</sup>	700501512
	<a href="#">IPO</a> <sup>211</sup> <a href="#">IP500</a> <sup>203</sup> <a href="#">COMB CARD ATM TAA</a> <sup>211</sup>	700501513
	<a href="#">IPO IP500 VCM 32 TAA V2</a> <sup>215</sup>	700504033
	<a href="#">IPO IP500 VCM 32 V3 MEDIA CARD TAA</a> <sup>215</sup>	700517170
<b>Trunk Daughter Cards</b>	<a href="#">IPO IP500 TRNK BRI 4 UNI TAA</a> <sup>219</sup>	700501515
	<a href="#">IPO IP500 TRNK PRI UNVRSL SNGL TAA</a> <sup>220</sup>	700501514
	<a href="#">IPO IP500 TRNK PRI UNVRSL DUAL TAA</a> <sup>220</sup>	700501517
	<a href="#">IPO IP500 TRNK PRI UNVRSL SNGL V2 TAA</a> <sup>220</sup>	700515487
	<a href="#">IPO IP500 TRNK PRI UNVRSL DUAL V2 TAA</a> <sup>220</sup>	700515488
<b>External Expansion Modules</b>	<a href="#">IPO IP500 EXP MOD ANLG TRNK 16 TAA</a> <sup>223</sup>	700501511
<b>Telephones</b>	<b>9608 IP Deskphone TAA Global</b>	700501428, 700507947
	<b>9608G IP Deskphone TAA Global</b>	700507946
	<b>9611G IP Deskphone TAA Global</b>	700501429, 700507948
	<b>9621G IP Deskphone TAA Global</b>	700500254, 700506516
	<b>9641G IP Deskphone TAA Global</b>	700501431, 700506519



# Chapter 13.

# Safety Statements

---

## 13. Safety Statements

The Avaya IP500 Office modules are intended to be installed by 'Service Personnel' and it is the responsibility of the Service Personnel to ensure that all subsidiary interconnected equipment is wired correctly and also meet the safety requirements of IEC60950 or UL60950 where applicable.



The CE mark affixed to this equipment means that the module complies with the 89/336/EEC (EMC) and 72/23EEC (LVD) Directives.

- The Declarations of Conformity (DoC) for the IP500 products are available on the IP Office Application DVD.
-  This warning symbol is found on the base of IP500 modules.
- Refer to [Trunk Interface Modules](#)<sup>299</sup> for information concerning which Trunk Interface module variants are fitted in which country.

In Finland, Norway and Sweden a protective earthing conductor must be attached to the protective earth point on the rear of the IP500 V2 control unit. See [Grounding](#)<sup>95</sup> for more information. In addition, the Server must be located in a restricted access location where equipotential bonding has been applied, for example, in a telecommunication center.

If you notice a malfunction or smoke, immediately disconnect the device from the power supply and contact the service center. Do not attempt to repair the device yourself, any repair should only be carried out by qualified technical personnel.

If you have any concern on the safety functioning of this product, please contact your system installer or Avaya Support at <https://www.avaya.com/en/services/avaya-support-services/>.

### 13.1 Lightning Protection/Hazard Symbols

#### Lightning protectors

The buildings lightning protectors must be verified as follow:

1. Check the lightning protectors, at the trunk cable entry point to the building housing the Avaya IP Office, paying special attention to the lightning protection grounding. Report any problems, in writing, to the telephone company.
2. Equipment that is designed to be connected using internal wiring is typically not lightning protected. Hence, Avaya IP Office extension cabling must not leave the building. For installations where telephones and/or other standard (tip/ring) devices are installed in another building then lightning protection is required (see [Out of Building Telephone Installations](#)<sup>36</sup>).



#### Hazard Symbol

The shock hazard symbol is intended to alert personnel to electrical hazard or equipment damage. The following precautions must also be observed when installing telephone equipment:

1. Never install telephone wiring during a lightning storm.
2. Never install telephone jacks in wet locations unless the jack is specifically designed for wet locations.
3. Never touch uninsulated telephone wires or terminals unless the telephone line has been disconnected at the network interface.
4. Always use caution when working with telephone lines.

## 13.2 Trunk Interface Modules

To ensure the validation of the approvals, only the following types of trunk interface cards must be fitted in the following IP Office control units.

USA/Canada						
Product	Quad BRI	PRI E1		PRI T1		Analog Trunk Card
		Single	Dual	Single	Dual	
IP500 V2	×	×	×	✓	✓	✓
IP500	×	×	×	✓	✓	✓

Rest of World						
Product	Quad BRI	PRI E1/E1R2		PRI T1		Analog Trunk Card
		Single	Dual	Single	Dual	
IP500 V2	✓	✓	✓	×	×	✓
IP500	✓	✓	✓	×	×	✓

### Notes

- E1R2 trunks are only supported in CALA and Korea.

## 13.3 Further Information and Product Updates

Further information, including Product and Reference Manual updates, can be obtained from Avaya Dealers and Distributors or from Avaya's web site: <http://www.avaya.com>.

This guide is also available from the Avaya's support web site: <http://support.avaya.com>.

### Support Contacts

For initial help and support, contact your distributor/supplier. The following contact points are for Avaya authorized partners.

#### USA

Avaya provides a toll-tree Customer Helpline 24 hours a day:

- Name: Avaya Technical Support Organization (TSO)
- Customer Helpline: 1 800 628-2888
- Address: 8744 Lucent Blvd., Highlands Ranch, Colorado, 80129 USA
- URL: <http://support.avaya.com>

If you need assistance when installing, programming, or using your system, call the Helpline or your Avaya representative. Consultation charges may apply.

#### Russia

Avaya CIS address (as representative office): «Авайя СНГ», 115054 Российская Федерация, г. Москва, Космодамианская наб., д. 52, стр. 3 Телефон: +74953636700

#### Other Locations

If you need assistance when installing, programming, or using your system, contact your Avaya representative.

- URL: <http://support.avaya.com>

## 13.4 Port Safety Classification

The Avaya IP Office systems have the following ports which are classified as follows:

Port Name	Port Description	Port Classification
<b>PRI port</b>	PRI ISDN connection (NET)	TNV (Operating within the limits of SELV)
<b>BRI ports</b>	BRI ISDN connection (NET)	TNV (Operating within the limits of SELV)
<b>Analog ports</b>	Two wire analog trunk	TNV3
<b>Power fail ports</b>	Two wire analog trunk	TNV3
<b>RS232 DTE port</b>	Async Data connection.	SELV
<b>Analog Telephone Ports</b>	Telephone Extension ports	TNV2
<b>Digital Telephone Ports</b>	Telephone Extension ports	SELV
<b>LAN ports</b>	10/100 BaseT attachment to LAN.	SELV
<b>Expansion ports</b>	Expansion Module connector.	SELV
<b>Audio port</b>	Connector for Music on Hold.	SELV
<b>External Control port</b>	Connector for Controlling Ancillary circuits.	SELV
<b>DC Input port</b>	Connector for DC input power.	SELV

Interconnection circuits shall be selected to provide continued conformance with the requirements of EN 609050:1992/A3:1995 clause 2.3 for SELV circuits and with the requirements of clause 6 for TNV circuits, after connections between equipment.

## 13.5 EMC Directive

889/336/ EEC (EMC Directive) CISPR 22:1993 including A1 + A2, AS/NZ 3548:1995 (ROW)

- **⚠ WARNING**

This is a class A product. In a domestic environment this product may cause radio interference in which case the user may be required to take adequate measures.

### Federal Communications Commission (FCC)

This equipment has been tested and found to comply with the limits for a Class A digital device, pursuant to Part 15 of the FCC Rules. These limits are designed to provide reasonable protection against harmful interference when the equipment is operated in a commercial environment. This equipment generates, uses, and can radiate radio frequency energy and, if not installed and used in accordance with the instruction manual, may cause harmful interference to radio communications. Operation of this equipment in a residential area is likely to cause harmful interference, in which case the user will be required to correct the interference at his or her own expense.

### Canadian Department of Communications (DOC)

"NOTICE: This equipment meets the applicable Industry Canada Terminal Equipment Technical Specifications. This is confirmed by the registration number. The abbreviation, IC, before the registration number signifies that registration was performed based on a Declaration of Conformity indicating that Industry Canada technical specifications were met. It does not imply that Industry Canada approved the equipment."

### EMC Caution for China

## 警示

注意：此为A级产品，在生活环境中，该产品可能会造成无线电干扰。在这种情况下，可能需要用户对其干扰采取切实可行的措施。仅适用于商业或工业环境。

---

## 13.6 Regulatory Instructions for Use

### 13.6.1 Australia

#### Connection

Connection of IP Office products must be via a Line Isolation Module with a telecommunications compliance label.

#### **BRI Interface**

During the configuration, ensure "000" emergency number is not barred, by performing the following:

- Short Code: 000
- Telephone No: 000;
- Function: DialEmergency

Connections to TS013, the following Bearer Capabilities shall not be used:

- 7kHz Audio, Video, Restricted Digital Information.

If unknown type of number is used in calling party number, the network will use the default CLI.

The system must be configured for Point to Multi point connection to comply with Austel requirements for connecting to TS013 circuits.

As the IP Office does not support emergency dialing after loss of power, the following warning notice should be recognized:

- **WARNING**  
This equipment will be inoperable when mains power fails.

#### PRI Interface

During the configuration, ensure "000" emergency number is not barred, by performing the following:

- Short Code: 000
- Telephone No: 000;
- Function: DialEmergency

- **WARNING**  
This equipment will be inoperable during mains power failure.

### 13.6.2 Canada

This equipment meets the applicable Industry Canada Terminal Equipment Technical Specifications. This is confirmed by the registration number. The abbreviation, IC, before the registration number signifies that registration was performed based on a Declaration of Conformity indicating that Industry Canada technical specifications were met.

It does not imply that Industry Canada approved the equipment.

"NOTICE: The Ringer Equivalence Number (REN) for this terminal equipment is 1. The REN assigned to each terminal equipment provides an indication of the maximum number of terminals allowed to be connected to a telephone interface. The termination on an interface may consist of any combination of devices subject only to the requirement that the sum of the Ringer Equivalence Numbers of all the devices does not exceed five."

13.6.3 China



700433220

February 2007

Copyright© 2007, Avaya Inc. All Rights Reserved

**所有在中华人民共和国境内进口或销售的电子信息产品必须附上本文件**  
**Include this document with all Electronic Information Products imported or sold in the People's Republic of China**

部件名称 (Part Name)	有毒有害物质或元素 (Hazardous Substance)					
	铅 (Pb)	汞 (Hg)	镉 (Cd)	六价铬 (Cr <sup>6+</sup> )	多溴联苯 (PBB)	多溴二苯醚 (PBDE)
金属部件 (Metal Parts)	×	○	○	○	○	○
电路模块 (Circuit Modules)	×	○	○	○	○	○
电缆及电缆组件 (Cables & Cable Assemblies)	×	○	○	○	○	○
塑料和聚合物部件 (Plastic and Polymeric parts)	○	○	○	○	○	○
电路开关/断路器 (Circuit Switch/Breakers)	○	○	○	○	○	○
电源组件 (Power Assemblies)	×	○	○	○	○	○
显示器 ( LCD, Monitor )	○	○	○	○	○	○
玻璃 (Glass)	○	○	○	○	○	○

- : 表示该有毒有害物质在该部件所有均质材料中的含量均在 SJ/T 11363 2006 标准规定的限量要求以下。  
Indicates that the concentration of the hazardous substance in all homogeneous materials in the parts is below the relevant threshold of the SJ/T 11363 2006 standard.
- × : 表示该有毒有害物质至少在该部件的某一均质材料中的含量超出 SJ/T 11363 2006 标准规定的限量要求。  
Indicates that the concentration of the hazardous substance of at least one of all homogeneous materials in the parts is above the relevant threshold of the SJ/T 11363 2006 standard.

本表显示，所附的亚美亚电子信息产品中，从生产日期起，可能包含这些物质。注意：所附产品可能包含或不包含以上所列的某些组件。

This table shows where these substances may be found in Avaya's electronic information products, as of the date of manufacture of the enclosed product. Note that some of the component types listed above may or may not be a part of the enclosed product.

除非有另外特别的标注,此标志将作为所附产品及零部件的环保使用期标志. 某些产品会有一个不同的环保使用期(例如,电话机)并贴在其产品上.此环保使用期限只适用于产品在产品手册中所规定的条件下使用



The Environmentally Friendly Use Period (EFUP) for all enclosed products and their parts are per the symbol shown here, unless otherwise marked. Certain products have a different EFUP (for example, telephones) and so are marked to reflect such. The Environmentally Friendly Use Period is valid only when the product is operated under the conditions defined in the product manual.

### 13.6.4 Japan

The power cord set included in the shipment or associated with the product is meant to be used with the said product only. Do not use the cord set for any other purpose. Any non-recommended usage could lead to hazardous incidents like fire disaster, electric shock, and faulty operation.

本製品と同梱または付属している電源コードセットは、本製品専用です。本製品以外の製品ならびに他の用途で使用しないでください。火災、感電、故障の原因となります

If this is a Class A device:

This is a Class A product based on the standard of the Voluntary Control Council for Interference by Information Technology Equipment (VCCI). If this equipment is used in a domestic environment, radio disturbance may occur, in which case, the user may be required to take corrective actions.

この装置は、情報処理装置等電波障害自主規制協議会（VCCI）の基準に基づいてクラスA情報技術装置です。この装置を家庭環境で使用すると電波妨害を引き起こすことがあります。この場合には使用者が適切な対策を講ずるよう要求されることがあります

If this is a Class B device:

This is a Class B product based on the standard of the Voluntary Control Council for Interference from Information Technology Equipment (VCCI). If this is used near a radio or television receiver in a domestic environment, it may cause radio interference. Install and use the equipment according to the instruction manual.

この装置は、情報処理装置等電波障害自主規制協議会（VCCI）の基準に基づいてクラスB情報技術装置です。この装置は、家庭環境で使用することを目的としていますが、この装置がラジオやテレビジョン受信機に近接して使用されると、受信障害を引き起こすことがあります。取扱説明書に従って正しい取り扱いをしてください

### 13.6.5 European Union

1. 999 and 112 calls must not be barred. Doing so will invalidate the approval.
2. All connections at the MDF shall be identifiable by suitable labeling.
3. The CE mark displayed on IP Office equipment indicates the systems compliance with the EMC, LVD, and R&TTE Directives and common technical regulations for Primary Rate and Basic Rate ISDN.
4. All ports for the connection of other non-telecommunications apparatus have a Safety Extra Low Voltage (SELV) safety status.

## European Union Declarations of Conformity

Avaya LLC declares that the equipment specified in this document bearing the "CE" (Conformité Européenne) mark conforms to the European Union Radio and Telecommunications Terminal Equipment Directive (1999/5/EC), including the Electromagnetic Compatibility Directive (2004/108/EC) and Low Voltage Directive (2006/95/EC).

Copies of these Declarations of Conformity (DoCs) can be obtained by contacting your local sales representative and are available on the following Web site: <http://support.avaya.com/DoC>.



### European Union Battery Directive

Avaya LLC supports European Union Battery Directive 2006/66/EC. Certain Avaya LLC products contain lithium batteries. These batteries are not customer or field replaceable parts. Do not disassemble. Batteries may pose a hazard if mishandled.

### **13.6.6 New Zealand**

The grant of a Telepermit for any item of terminal equipment indicates only that Telecom has accepted that the item complies with minimum conditions for connection to its network. It indicates no endorsement of the product by Telecom, nor does it provide any sort of warranty. Above all, it provides no assurance that any item will work correctly in all respects with another item of Telepermitted equipment of a different make or model, nor does it imply that any product is compatible with all of Telecom's network services.

### 13.6.7 FCC Notification

This equipment complies with Part 68 of the FCC rules and the requirements adopted by the Administrative Council on Terminal Attachments (ACTA). On the rear of this equipment is a label that contains, among other information, a product identifier in the format US:AAAEQ##TXXX. If requested, this number must be provided to the telephone company.

The REN is used to determine the quantity of devices that may be connected to the telephone line. Excessive RENs on the telephone line may result in devices not ringing in response to an incoming call. In most, but not all areas, the sum of RENs should not exceed 5.0. To be certain of the number of devices that may be connected to a line, as determined by the total RENs, contact the local telephone company. For products approved after July 23, 2001, the REN for this product is part of the product identifier that has the format US:AAAEQ##TXXX. The digits represented by ## are the REN without a decimal point (for example, 03 is a REN of 0.3). For earlier products, the REN is separately shown on the label.

### Means of Connection

Connection of this equipment to the telephone network is shown in the following table.

Port	FIC	SOC	USOC Jack	REN
IP500 PRI 1U, IP500 PRI2U	04DU9.BN, 04DU9.DN, 04DU9.IKN, 04DU9.ISN	6.0Y	RJ48C	NA
IP500 ATM4U	OL13A, OL13B, OL13C, 02AC2, 02LA2, 02LB2, 02LC2, 02LR2, 02LS2	9.0Y	RJ45S	0.1B
IP500 ATM16	OL13A, OL13B, OL13C, 02AC2, 02GS2, 02LA2, 02LB2, 02LC2, 02LR2, 02LF2 02GS2, 02LS2	9.0Y	RJ45S	0.1B

If this equipment causes harm to the telephone network, the telephone company will notify you in advance that temporary discontinuance of service may be required. But if advance notice is not practical, the telephone company will notify the customer as soon as possible. Also, you will be advised of your right to file a complaint with the FCC if you believe it is necessary.

The telephone company may make changes in its facilities, equipment, operations or procedures that could affect the operation of the equipment. If this happens, the telephone company will provide advance notice in order for you to make necessary modifications to maintain uninterrupted service.

If trouble is experienced with this equipment, for repair or warranty information, please contact the Technical Service Center at 1-800-242- 2121 or contact your local Avaya representative. If the equipment is causing harm to the telephone network, the telephone company may request that you disconnect the equipment until the problem is resolved.

A plug and jack used to connect this equipment to the premises wiring and telephone network must comply with the applicable FCC Part 68 rules and requirements adopted by the ACTA.

Connection to party line service is subject to state tariffs. Contact the state public utility commission, public service commission or corporation commission for information.

### **Equipment With Direct Inward Dialing ("DID"):**

Allowing this equipment to be operated in such a manner as to not provide proper answer supervision is a violation of Part 68 of the FCC's rules.

Proper Answer Supervision is when:

- A. This equipment returns answer supervision to the public switched telephone network (PSTN) when DID calls are:
  - answered by the called station,
  - answered by the attendant,
  - routed to a recorded announcement that can be administered by the customer premises equipment (CPE) user.
  - Routed to a dial prompt
- B. This equipment returns answer supervision signals on all (DID) calls forwarded back to the PSTN. Permissible exceptions are:
  - A call is unanswered.
  - A busy tone is received.
  - A reorder tone is received.

Avaya attests that this registered equipment is capable of providing users access to interstate providers of operator services through the use of access codes. Modification of this equipment by call aggregators to block access dialing codes is a violation of the Telephone Operator Consumers Act of 1990.

### **Automatic Dialers:**

When programming emergency numbers and (or) making test calls to emergency numbers:

1. Remain on the line and briefly explain to the dispatcher the reason for the call.
2. Perform such activities in the off-peak hours, such as early morning or late evenings.

### **Toll Restriction and Least Cost Routing Equipment:**

The software contained in this equipment to allow user access to the network must be upgraded to recognize newly established network area codes and exchange codes as they are placed into service.

Failure to upgrade the premises systems or peripheral equipment to recognize the new codes as they are established will restrict the customer and the customer's employees from gaining access to the network and to these codes.

### **FCC Part 68 Supplier's Declarations of Conformity**

Avaya LLC in the United States of America hereby certifies that the equipment described in this document and bearing a TIA TSB-168 label identification number complies with the FCC's Rules and Regulations 47 CFR Part 68, and the Administrative Council on Terminal Attachments (ACTA) adopted technical criteria.

Avaya further asserts that Avaya handset-equipped terminal equipment described in this document complies with Paragraph 68.316 of the FCC Rules and Regulations defining Hearing Aid Compatibility and is deemed compatible with hearing aids.

---

## 13.6.8 Compliance with FCC Rules

### Transmit and Receive Gain Settings for PRI/T1 and Analog Ports

The Gain settings are password controlled for use by qualified installation personnel only and must not be made available to the end user. The default gain settings of 0dB ensures compliance with FCC part 68 section 68.308(b) (5) and TIA/EIA-IS-968 Section 4.5.2.5. "Through transmission amplification from ports for the connection of separately registered equipment or from other network connection ports". Gain setting adjustment by unqualified personnel may result in violation of the FCC rules. Qualified personnel may adjust gain settings above these levels only where:

1. Measurement is made to ensure that the power levels sent to line at each network interface connected does not exceed the maximum levels specified in FCC part 68 section 68.308(b) and TIA/EIA-IS-968 Section 4.5 for that specific interface type.
2. Where gain adjustment away from the default values are made, precautions should be taken to ensure that the connection of terminal equipment is controlled by qualified installation personnel.
3. To conform with the Receive Objective Loudness Rating at distances greater than 2.7km from the central office, on analog trunks a receive gain of 1.5dB must be set.

# Index

## A

- Analog
  - Phone Barrier Boxes 186
  - Phone Region Availability 39, 239
  - Port 256, 259
- Application
  - Call Center 45
  - Call Logging 45
  - CD/DVD 42
  - CTI 45
  - Maintenance 43
  - Manager 246
  - Monitor 247
  - SoftConsole 248
  - System Status Application 248
  - TAPI 249
  - User 44
  - Voicemail 44
  - VoiceMail Pro 250
- Assessments
  - Network 40
  - VoIP 40
- Audio
  - Codec Conversion 41
  - Port 256
- Audio Port 259
- Availability of Equipment 13

## B

- Backup
  - SD Card 144
- Barrier Boxes
  - Analog Phone 186
  - Rack Mounting 187
- Base Card
  - Analog Phone 23, 207
  - Digital Station 23, 207
  - VCM 23, 207
- BRI
  - (So) Port 260
  - (Trunk) Port 261
  - Port 256

## C

- Cable 53
  - Access Requirements 53
  - Clearance Requirements 53
- Cables
  - Maximum Cable Distances 33, 257
  - Standard IP Office 33, 257
- Cabling
  - Lightening Protection 36, 184
- Call Logging Application 45
- Call Status
  - Application 43
- Cards
  - IP500 Analog Phone Base 210
  - IP500 Digital Station Base 213
  - IP500 VCM 215
- Castle Rock 189
- Channels
  - Compression 41
- Citrix 253
- Clock 108

- Compact Business Center
  - Application 45
- Compact Contact Center
  - Application 45
- Compression Channels 41
- Conference Center
  - Application 44
- Configuration
  - Create New 78
  - Erase 167
- Connections
  - Grounding 35
  - Out of Building 36, 184
- ContactStore
  - Application 44
- Control Unit
  - Rack Mounting 37
  - Wall Mounting 37
- Copy
  - SD Card 146
- Country
  - Languages 17
  - Supported Locales 17
- Create Configuration 78

## D

- Daughter Cards
  - Analog Trunk 25, 218
  - BRI Trunk 25, 219
  - PRI Trunk 220
  - PRI-U Trunk 25
  - Trunk 25
- DC I/P
  - Port 256
- DCI I/P Port 262
- DECT
  - Phone 39, 239
  - Region Availability 39, 239
- Desktop Virtualization 253
- DevLink Application 45
- DS
  - IROB 185
  - Phone 39, 185, 239
  - Port 256, 262
  - Region Availability 39, 239
- DTE Port 195
  - Cable requirement 268
  - RS232 268
  - Settings 268

## E

- Embedded Voicemail
  - Application 44
- EMC Cautions
  - Canadian Department of Communications 291
  - EMC Caution for China 291
  - Federal Communications Commission 291
- Envirmental Requirements 51
- Equipment Availability 13
- Expansion
  - Port 256
- Expansion Modules
  - IP400 Analog Trunk 16 231
  - IP400 Digital Station V2 233
  - IP400 Phone V2 235
  - IP500 Analog Trunk 16 223

---

Expansion Modules  
  IP500 Digital Station 26  
  IP500 Phone 26, 228  
  IPO 500 Analog Trunk 26  
  IPO 500 BRI So8 26

Expansion Port 263

Exporting Settings 79

EXT O/P  
  Port 256

EXT O/P Port 188, 263

Extension Numbers  
  Swapping 183

External Expansion Modules 26

**F**

Faulty Units 13

FCC Rules 298

Feature Key Server  
  Application 43

Feature Keys  
  Parallel 21  
  Serial 21  
  Smart Card 21  
  USB 21

Firewall Exceptiong 251

**G**

General Information  
  Training Courses 46  
  Web Sites 46

Grounding Control Units 35

**H**

H323  
  Phones 39, 239  
  Region Availability 39, 239

Hazard Symbols 288

Hazardous Substances 13

Homologation Statement 288

HP OpenView 189

**I**

Importing Settings 79

IP Office Operation in  
  Australia 292  
  Canada 292  
  China 293  
  European Union 294  
  New Zealand 295  
  USA 296

IP500  
  Analog Phone Base Card 23, 207  
  Analog Trunk Daughter Card 25  
  BRI Trunk Daughter Card 25  
  Digital Station Base Card 23, 207  
  PRI-U Trunk Daughter Card 25  
  Reset Button 194  
  Trunk Daughter Card 25  
  VCM Base Card 23, 207

IP500 Installation  
  Admin Applications 68  
  Card 84  
  Check Card LED 97  
  Connect Manager 70  
  Documentation 62  
  Grounding 95  
  Rack Mounting 91

Start Manager 71

Tools 61

Unpacking 63

**L**

LAN  
  Port 256

LAN Port 264

Licences  
  Manager 246  
  Monitor 247  
  SoftConsole 248  
  Syatem Status Application 248  
  TAPI 249  
  VoiceMail Pro 250

Licenses  
  PC-Base 21  
  PC-Less 21

Lightening Portection 288

Lightening Protection 36, 184

**M**

Maintenance  
  Applications 43

Manager  
  Application 43  
  Clock Quality 108  
  Components 246  
  License Requirements 246  
  PC Requirements 246  
  Prefix Dialing 110  
  Trunks 107  
  Upgrade Software 177

Memory card  
  Removal 138

Modules  
  Trunk Interface 289

Monitor  
  Application 43  
  Components 247  
  License Requirements 247  
  PC Requirements 247  
  Protocols 251

MS-CRM  
  Application 44

**N**

Network Assessments 40

New Configuration 78

**O**

Out of Building  
  Connections 36, 184

**P**

Paint 276

Parallel Feature Key 21

PC-Base Licensing 21

PC-Less Licensing 21

PF  
  Port 256

PF Port 265

Phone (POT)  
  Port 256

Phone (POT) Port 266

Port  
  Analog 256, 259  
  Assigned 251

- Port
  - Audio 256, 259
  - BRI 256
  - BRI (So) 260
  - BRI (Trunk) 261
  - DC I/P 256
  - DCI I/P 262
  - Door 188
  - DS 256, 262
  - Expansion 256, 263
  - EXT O/P 188, 256, 263
  - IP Office 251
  - LAN 256, 264
  - PF 256, 265
  - Phone (POT) 256, 266
  - PRI 256, 267
  - RS232/DTE 256
  - RS323 DTE 268
  - Safety Classification 290
  - USB 256
  - Used 251
  - WAN 256
- Power Supplies
  - 1151C1 30
  - 1151C2 30
  - Cords 31
  - Type 40w PSU 30
  - Type 45W Earthed PSU 30
  - Type 60W Earthed PSU 30
  - Uninterrupted Power Supply 32
- PRI
  - Port 256
- PRI Port 267
- Protocols 251
- R**
- Rack Mounting Control Units 37
- Region Availability
  - Analog Phone 39, 239
  - DECT Phone 39, 239
  - DS Phone 39, 239
  - H323 Phone 39, 239
- Remove
  - SD Card 138
- Requirements
  - Cable Access 53
  - Cable Clearance 53
  - Environmental 51
  - Space 53
  - Wall Mounting 51
- Restore
  - SD Card 145
- RoHS 13
- RS232/DTE
  - Port 256
- S**
- Safety Statement 288
- SD Card
  - Backup 144
  - Copy 146
  - Removal 138
  - Restore 145
- Security Settings
  - Default 170
- Serial Feature Key 21
- Settings
  - CSV File Formats 79
  - Exporting 79
  - Importing 79
  - Smart card Feature Key 21
  - SNMP 189
    - Enabling 192
    - Installation 190
    - Port 192
    - respond 192
    - Trap Sending 192
  - SNMP MIBs
    - Application 43
  - SoftConsole
    - Application 44
    - Components 248
    - License Requirements 248
    - PC Requirements 248
  - Software
    - Erase Core Software 196
  - Space Requirements 53
  - Statement
    - Homologation 288
    - Safety 288
  - Supported
    - Language 17
    - Locales 17
  - System Status
    - Application 43
  - System Status Application
    - Components 248
    - License Requirements 248
    - PC Requirements 248
- T**
- TAPI
  - Components 249
  - License Requirements 249
  - PC Requirements 249
  - WAV Driver Application 45
- TAPILink Lite
  - Application 44
- TAPILink Pro Application 45
- Terminal Services 253
- Training Courses 46
- Trunk Interface Modules 289
- U**
- USB
  - Feature Key 21
  - Port 256
- V**
- VDI 253
- Voice Compression Channels 41
- VoiceMail Lite
  - Application 44
- VoiceMail Pro
  - Application 44
  - Components 250
  - License Requirements 250
  - PC Requirements 250
- VoIP Assessments 40
- W**
- Wall Mounting Control Units 37
- Wall Mounting Requirements 51

---

WAN

Port 256

Web Sites 46



