

# Pre-Installation Network Worksheet—S8700 IP Connect



---

## S8700 Media Server for IP Connect Configuration

Before an Avaya S8700 Media Server for IP Connect Configurations can be installed, data must be gathered to facilitate the configuration of the media servers.

Allow up to 4 hours to complete the worksheet. If you do not have this information complete, **DO NOT BEGIN THE SERVER CONFIGURATION. DO NOT GUESS AT THESE NUMBERS.** To do so could corrupt the customer's network.

Review this worksheet with and get the data to fill it out from the customer corporate **LAN administrator**.

Default values are shown in braces.

 **NOTE:**

The administrator may require you to change IP addresses to prevent conflicts with existing endpoints on the corporate LAN. Make precise notes of any changes and follow instructions exactly.

 **CAUTION:**

*It is crucial to coordinate the IP addresses that will be used with your Avaya S8700 Media Server with those on the corporate LAN. If you specify an Ethernet address for the media server component that conflicts with another Ethernet endpoint, the resulting problems with traffic on the local area network may be extremely difficult to diagnose and solve.*

This worksheet is made up of the following sections:

- [QoS Policy](#)
- [License and Registration Data](#)
- [S8700 IP Connect Network Worksheet](#)
- [Other Media Server complex components](#)
- [IPSI IP Addresses](#)
- [Other Interfaces](#)

## QoS Policy

---

The network administrator must define the quality policy for telephony applications on the corporate enterprise network.

## QoS Design Background

---

Will VLANs and Priority be used? (Y/N)\_\_\_\_\_

If Yes:

- What priority (6 recommended)\_\_\_\_\_
- What VLAN(s)\_\_\_\_\_
- (Show VLAN assignment by Subnet if not consistent across the Corporate Enterprise LAN)
- Will VLAN IDs for the media server be tagged in the telephony product or by the Ethernet switch?\_\_\_\_\_
- \_\_\_\_\_
- Will priority be tagged in the telephony product or by the Ethernet switch?\_\_\_\_\_
- Will VLAN IDs for the IP telephones be tagged by the telephones or by the Ethernet Switch?\_\_\_\_\_
- \_\_\_\_\_
- (If by Ethernet switch, configure VLAN IDs in the DHCP server)

Will Diffserve be used on IP connections? (Y/N)\_\_\_\_\_

- What Diffserver Value for Telephony will be used?\_\_\_\_\_
- (Recommend 46)
- What Refresh time?\_\_\_\_\_
- What Retry?\_\_\_\_\_
- What Profile?\_\_\_\_\_

---

## **License and Registration Data**

---

The following information is required when using the either the Remote Feature Activation (RFA) web site or the Automatic Registration Tool (ART) web site.

### **RFA Data**

---

SAP Order number: \_\_\_\_\_

Serial Number of 'Reference' TN2312 IP Server Interface (IPSI) circuit pack: \_\_\_\_\_

This serial number may not be available until delivery of equipment. This serial number is used in the creation of the license file that will be used on the S8700 Media Server. The IPSI circuit pack that will be closest, from a logical data point of view, to the media servers should be selected. This will decrease the amount of intervening equipment that could cause a lapse in communication with the reference IPSI.

#### **⇒ NOTE:**

Product/alarm ID (PID) numbers will be obtained by RFA and incorporated into the media servers via the license file.

### **Automatic Registration Tool Data**

---

Full telephone number for the line used to access the S8700 Media Server modems: \_\_\_\_\_

ART needs this information to generate a skeleton MAESTRO record for the S8700 Media Server installation. ART will provide the following information to the user:

- Two Avaya IP addresses to configure into the media servers. See item(s) 7a, 7b under the "For the Set Modem Interface screen" on page -10

### **Software Release - Patches - Firmware Versions**

---

Enter the software release that should be installed on the S8700 Media Servers: \_\_\_\_\_

Enter any patches that should be installed on the S8700 Media Servers: \_\_\_\_\_

Enter the firmware version that should be installed on the TN2312 IPSI boards: \_\_\_\_\_

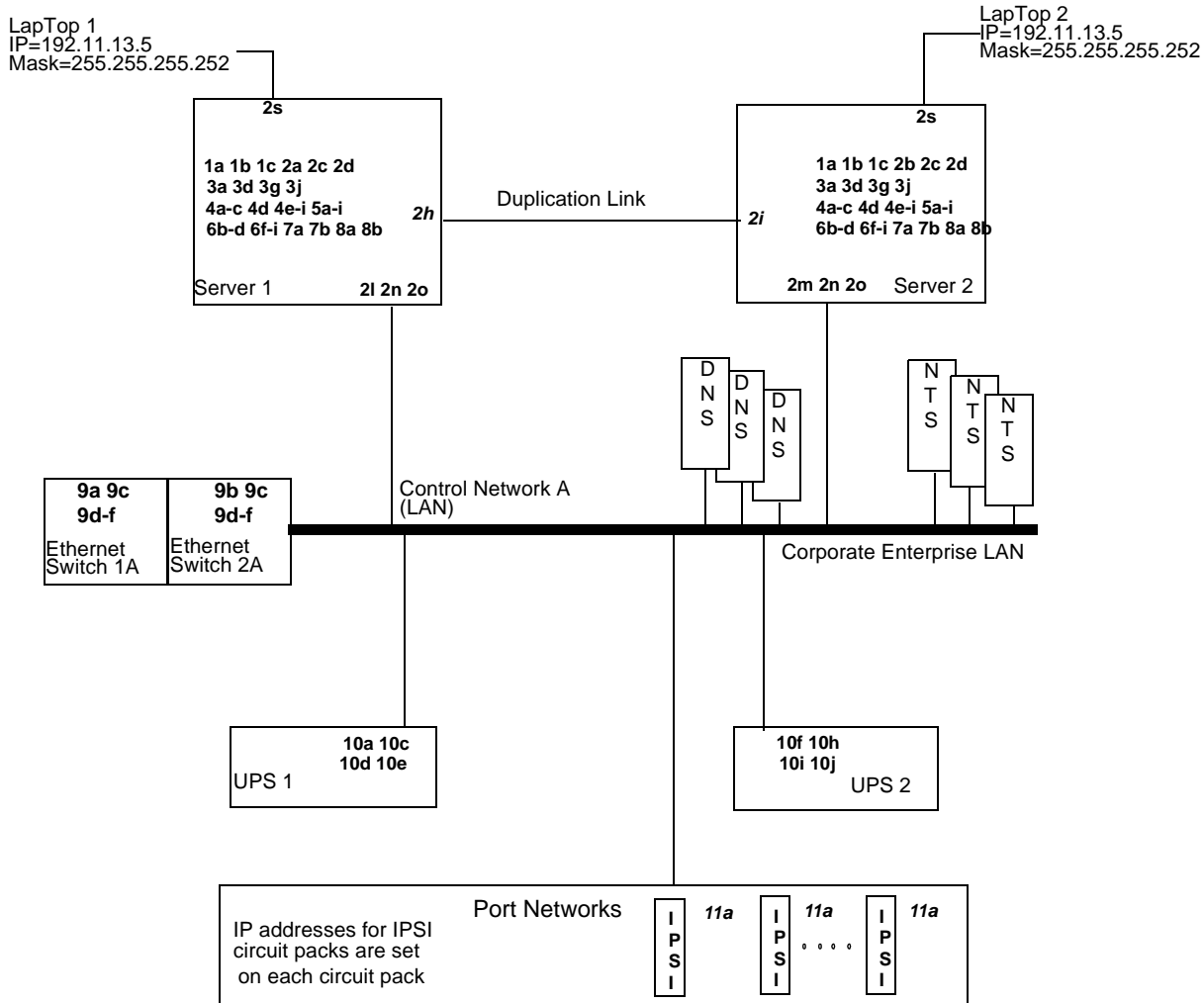

IP Connect Component Connectivity

## **S8700 IP Connect Network Worksheet**

The following worksheet items are arranged in the order in which they are needed during media server configuration. Individual items are numbered in the following form (1a, 2a, 3a, etc.) For an illustration of some of these items and where they are used, see IP connect component connectivity Figure on page -4.

Values in braces {aaa.bbb.ccc.ddd} indicate defaults that may be used in some cases. An example would be the duplication link (Items **2h - 2k**) which can always use the defaults. Extreme caution must be exercised when using defaults to ensure that conflicts are not created in the corporate LAN.

### **For the Set Server Identities screen**

Server numbers 1 & 2 must be on the same subnet (be sure to configure both media servers)

#### **Server names**

These should also be administered on any relevant corporate DNS servers

**1a** Name of server 1: \_\_\_\_\_

**1b** Name of server 2: \_\_\_\_\_

**1c** Active server name: \_\_\_\_\_

#### **Ethernet interface functions**

The corporate LAN function may be assigned to Ethernet 4 if the IP-Connect configuration uses a dedicated LAN for its control network

**1d** Function assigned to Ethernet 0: {control network A plus the corporate LAN, if a dedicated control network is not used} \_\_\_\_\_

**1e** Function assigned to Ethernet 1: {services laptop} \_\_\_\_\_

**1f** Function assigned to Ethernet 2: {duplication link} \_\_\_\_\_

**1g** Function assigned to Ethernet 4: {corporate LAN, if a dedicated control network is used} \_\_\_\_\_

**For the Configure Ethernet Interfaces screen**

**Ethernet 0 addresses**

**(for control network A plus the corporate LAN if a dedicated control network is not used):**

**2a** Server 1 IP address on control network A/corporate LAN: {} \_\_\_\_\_

**2b** Server 2 IP address on control network A/corporate LAN: {} \_\_\_\_\_

**2c** Active server IP address on control network A/corporate LAN: {} \_\_\_\_\_

**2d** Gateway IP address for control network A/corporate LAN: \_\_\_\_\_

**2e** Subnet mask for control network A/corporate LAN: {} \_\_\_\_\_

**2f** Speed of link (10 or 100 megabit, full or half duplex): {autosense} \_\_\_\_\_

**2g** VLAN 802.1q priority tagging: {off} \_\_\_\_\_

Note: Tagging should be set the same on both control networks.

**Ethernet 2 addresses**

**(for duplication link, defaults in braces):**

**2h** Server 1 IP address on duplication link: {192.11.13.13} \_\_\_\_\_

**2i** Server 2 IP address on duplication link: {192.11.13.14} \_\_\_\_\_

**2j** Subnet mask for the duplication link: {255.255.255.252} \_\_\_\_\_

**2k** Speed of link (100 megabit, full duplex): {autosense} \_\_\_\_\_

**Ethernet 3 addresses**

**(not used in default IP Connect configuration).**

**Ethernet 4 addresses**

**(for corporate LAN if a dedicated control network is used, no default values):**

**2l** Server 1 IP address on the corporate LAN: \_\_\_\_\_

**2m** Server 2 IP address on the corporate LAN: \_\_\_\_\_

**2n** Active server IP address on the corporate LAN: \_\_\_\_\_

**2o** Gateway IP address for the corporate LAN: \_\_\_\_\_

**2p** Subnet mask for the corporate LAN: \_\_\_\_\_

**2q** Speed of link (10 or 100 megabit, full or half duplex): {autosense} \_\_\_\_\_

**2r** VLAN 802.1q priority tagging: {off} \_\_\_\_\_

Note: Tagging should be set the same on both control networks.

**Ethernet 1 addresses**

**Fixed for the services interface:**

**⇒ NOTE:**

This address and subnet mask are fixed and not changeable.

**2s** IP address for every Avaya™ S8700 Media Server: 192.11.13.6

**2t** Subnet mask for the laptop link: 255.255.255.252

**For the Control Switches and UPS screen**

If Ethernet switches are part of the switch configuration and report alarms to the media servers using SNMP, they must be on the same subnet as the media servers.

**Specify the Ethernet switches**

These entries will be populated if a dedicated LAN is used. If the corporate enterprise LAN (non-dedicated) is to be used enter 0 (zero) for the number of Ethernet switches.

Number of Ethernet switches: {1} \_\_\_\_\_

**3a** Ethernet switch 1 IP address (CNA): {} \_\_\_\_\_ (9a also)

**3b** SNMP GET (read) community string: {public} \_\_\_\_\_ (9d also)

**3c** SNMP SET (write) community string: \_\_\_\_\_ (9e also)

**3d** Ethernet switch 2 IP address (CNA): {} \_\_\_\_\_ (9b also)

**3e** SNMP GET (read) community string: {public} \_\_\_\_\_ (9d also)

**3f** SNMP SET (write) community string: \_\_\_\_\_ (9e also)

**Specify the UPS units for the media server**

There are always 2 UPS units. The UPS units must be on the same subnet as the media servers and must report alarms through SNMP to the media servers in order for the media servers to respond correctly to a loss of power.

Number of UPS units: {2} \_\_\_\_\_

**3g** UPS 1 IP address: {} \_\_\_\_\_ (10a also)

**3h** SNMP GET (read) community string: {public} \_\_\_\_\_ (10d also)

**3i** SNMP SET (write) community string: \_\_\_\_\_ (10e also)

**3j** UPS 2 IP address: {} \_\_\_\_\_ (10f also)

**3k** SNMP GET (read) community string: {public} \_\_\_\_\_ (10i also)

**3l** SNMP SET (write) community string: \_\_\_\_\_ (10j also)

**For the DNS and DHCP Server Configuration screen**

Optional: If domain name service (DNS) servers are to be used, complete as many of the following fields as needed to set up DNS service and limit unresolved name searching. Fill out only as many server and search domain fields as are needed:

**4a** DNS server 1 IP address: \_\_\_\_\_

**4b** DNS server 2 IP address: \_\_\_\_\_

**4c** DNS server 3 IP address: \_\_\_\_\_

**4d** DNS domain name: \_\_\_\_\_

**4e** Search domain name 1: \_\_\_\_\_

**4f** Search domain name 2: \_\_\_\_\_

**4g** Search domain name 3: \_\_\_\_\_

**4h** Search domain name 4: \_\_\_\_\_

**4i** Search domain name 5: \_\_\_\_\_

**DHCP service**

DHCP service, to configure IPSI address information, is not currently available for S8700 IP Connect configurations.

**For the Set Static Network Routes screen**

Optional: Enter any static IP addresses specified by the customer's LAN administrator.

	IP address of endpoint server is trying to reach	Subnet mask used by all endpoints	Gateway IP address (optional)	Ethernet interface (optional)
5a				
5b				
5c				
5d				
5e				
5f				
5g				
5h				
5i				

**For the Network Time Server screen**

**6a** Is a Network Time Server (NTS) available to be used as the time source? (y/n) \_\_\_\_\_

Note: If a NTS is available, both media servers in the S8700 Media Server complex should be administered to synchronize with it. Select the second radio button on the screen and fill in the fields detailed below on **both** media servers.

If an external NTS is not available both media servers should have the first radio button selected on the Network Time Server screen. In this case Server 1 will always act as a Network Time Server and Server 2 will synchronize with it.

**If NTSs are available, enter their DNS names or IP addresses**

**6b** Primary NTS name or IP address: \_\_\_\_\_

Trusted Key \_\_\_\_\_ (Leave blank if not used)

**6c** Secondary NTS name or IP address: \_\_\_\_\_

Trusted Key \_\_\_\_\_ (Leave blank if not used)

**6d** Tertiary NTS name or IP address: \_\_\_\_\_

Trusted Key \_\_\_\_\_ (Leave blank if not used)

**6e** Multicast Client Support? (Y/N): \_\_\_\_\_

**Additional Keys**  
(Leave blank if not used)

Trusted Key: \_\_\_\_\_

Requested Key: \_\_\_\_\_

Control Key: \_\_\_\_\_

**6i** Will a *Keys file* be used (Y/N): \_\_\_\_\_

Note: If Yes, it must be supplied during this configuration step and should reside in the */var/home/ftp* directory.

**For the Set Modem Interface screen**

---

Specify the IP address for each media server's modem (this information must be provided by Avaya Services if a maintenance contract is in force):

**7a** IP address of the PPP dial-up link for server 1: \_\_\_\_\_

**7b** IP address of the PPP dial-up link for server 2: \_\_\_\_\_

Use the default return routes (unless specifically instructed to change them). The default return route codes for Avaya Service are:

Information	IP address	Subnet mask
Services return route for PPP dial-up connection (if Avaya supports)	135.9.0.0	255.255.0.0
	135.17.0.0	255.255.0.0
	135.39.0.0	255.255.0.0
	135.60.0.0	255.255.0.0
	198.152.171.0	255.255.255.0
	198.152.171.0	255.255.255.0

**For the Configure Trap Destinations screen**

---

Specify Simple Network Management Protocol (SNMP) data trap destination. This information enables the active server to send SNMP traps to a Network Management Station; for example, CajunView.

**8a** IP address of SNMP trap destination: \_\_\_\_\_

**8b** SNMP protocol version (1, 2c or 3): \_\_\_\_\_

**Required for version 1:**

**8c** Community name: \_\_\_\_\_

**Required for version 2c:**

**8d** Notification type (trap/inform): \_\_\_\_\_

**8e** Community name: \_\_\_\_\_

**Required for version 3:**

**8f** Notification type (trap/inform): \_\_\_\_\_

**8g** User name: \_\_\_\_\_

**8h** Security model (none, authentication, or privacy): \_\_\_\_\_

**8i** Authentication password (required for authentication and privacy model): \_\_\_\_\_

**8j** Privacy password (required for privacy model): \_\_\_\_\_

## **Other Media Server complex components**

These components may or may not be included for any given configuration. The following information will be configured directly in the indicated component.

### **Ethernet Switch(s) (9x)**

#### **IP Address on control network A**

**9a** Ethernet switch 1 IP address on control network A: {} \_\_\_\_\_

**9b** Ethernet switch 2 IP address on control network A: {} \_\_\_\_\_

#### **Trap receiver destination on control network A**

**9c** Trap receiver destination for both Ethernet switches on control network A:  
{Use the 'Active Server' IP address} \_\_\_\_\_

#### **Community Strings for Ethernet Switches**

**9d** Community String: {Public} \_\_\_\_\_ Community Access: {Read-Only} \_\_\_\_\_

**9e** Community String: {Public} \_\_\_\_\_ Community Access: {Read-Write} \_\_\_\_\_

**9f** Community String: {Public} \_\_\_\_\_ Community Access: {trap} \_\_\_\_\_

### **Uninterruptible Power Supplies**

#### **UPS 1**

**10a** UPS 1 IP address on control network A: {Use Server 1 IP address} \_\_\_\_\_

**10b** Subnet Mask for UPS 1 on control network A: {} \_\_\_\_\_

**10c** Default gateway for UPS 1 on control network A: {Use Active Server IP address} \_\_\_\_\_

**10d** SNMP GET (read) community string: {public} \_\_\_\_\_

**10e** SNMP SET (write) community string: \_\_\_\_\_

**UPS 2**

**10f** UPS 2 IP address on control network A: {Use Server 2 IP address}\_\_\_\_\_

**10g** Subnet Mask for UPS 2 on control network A: {}\_\_\_\_\_

**10h** Default gateway for UPS 2 on control network A: {Use Active Server IP address}\_\_\_\_\_

**10i** SNMP GET (read) community string: {public} \_\_\_\_\_

**10j** SNMP SET (write) community string: \_\_\_\_\_



## Other Interfaces

---

Control Lan (C-LAN - TN799C/DP), IP Media Processor (MP - TN2302AP), and Voice Announcement over Lan (VAL - TN2501AP) resources in the media gateway port networks requires network configuration. Use the following table to gather required information for these interfaces.

**⇒ NOTE:**

These resources are not shown in [“IP Connect Component Connectivity”](#). They will be configured using Avaya Site Administration in the MultiVantage software application.

